

# HITACHI

KAOHSIUNG HITACHI  
ELECTRONICS CO.,LTD  
P.O. BOX 26-27  
2,13TH EAST ST. K.E.P.Z.  
KAOHSIUNG TAIWAN R.O.C.  
TEL:(07) 821-5811(7 LINE)  
FAX:(07) 821-5815

FOR MESSRS : \_\_\_\_\_

DATE : May.28,2007

## Customer's Acceptance Specifications SP12N002 CONTENTS

No.	ITEM	SHEET No.	PAGE
1	COVER	7B64PS 2701 - SP12N002-3	1-1/1
2	RECORD OF REVISION	7B64PS 2702 - SP12N002-3	2-1/1
3	MECHANICAL DATA	7B64PS 2703 - SP12N002-3	3-1/1
4	ABSOLUTE MAXIMUM RATINGS	7B64PS 2704 - SP12N002-3	4-1/1
5	ELECTRICAL CHARACTERISTICS	7B64PS 2705 - SP12N002-3	5-1/1
6	OPTICAL CHARACTERISTICS	7B64PS 2706 - SP12N002-3	6-1/2~2/2
7	BLOCK DIAGRAM	7B64PS 2707 - SP12N002-3	7-1/1
8	INTERFACE TIMING CHART	7B64PS 2708 - SP12N002-3	8-1/2~2/2
9	DIMENSIONAL OUTLINE	7B63PS 2709 - SP12N002-3 7B64PS 2709 - SP12N002-3	9-1/3 9-2/3~3/3
10	APPEARANCE STANDARD	7B64PS 2710 - SP12N002-3	10-1/5~5/5
11	PRECAUTION IN DESIGN	7B64PS 2711 - SP12N002-3	11-1/3~3/3
12	DESIGNATION OF LOT MARK	7B64PS 2712 - SP12N002-3	12-1/1
13	PRECAUTION FOR USE	7B64PS 2713 - SP12N002-3	13-1/1

※When product will be discontinued, customer will be informed by HITACHI with twelve months prior announcement.

ACCEPTED BY: \_\_\_\_\_

PROPOSED BY: *Dan Cheng*

KAOHSIUNG HITACHI ELECTRONICS CO.,LTD.	Sh. No.	7B64PS 2701-SP12N002-3	PAGE	1-1/1
---	------------	------------------------	------	-------

## RECORD OF REVISION

DATE	SHEET No.	SUMMARY								
Nov.11,'03	7B64PS2705 - SP12N002-2 PAGE 5-1/1	Revised : 5.7 ELECTRICAL CHARACTERISTICS OF BACKLIGHT Backlight frequency Max. 8.5 → 85								
May.28,'07	7B64PS2709 - SP12N002-2 PAGE 9-1/3	9. DIMENSIONAL OUTLINE Changed : CFL I / F : Mitsumi M63M83 - 04 → JAE IL-G-4S-S3C2-SA								
	7B64PS2709 - SP12N002-2 PAGE 9-3/3	9.3 INTERFACE PIN CONNECTION Changed : CFL I / F : Mitsumi M63M83 - 04 → JAE IL-G-4S-S3C2-SA								
	7B64PS2712 - SP12N002-2 PAGE 12-1/1	12. DESIGNATION OF LOT MARK Added <table border="1" style="margin-left: 20px; border-collapse: collapse; width: 80%;"> <thead> <tr> <th style="width: 15%;">REV No.</th> <th style="width: 50%;">ITEM</th> <th style="width: 35%;">LOT No.</th> </tr> </thead> <tbody> <tr> <td style="text-align: center;">A</td> <td>CCFL tube diameter (<math>\phi 2.6 \rightarrow \phi 2.4</math>)</td> <td style="text-align: center;">-</td> </tr> <tr> <td style="text-align: center;">B</td> <td>CFL I/F Connector : Mitsumi M63M83-04 → JAE IL-G-4S-S3C2-SA</td> <td style="text-align: center;">7102T</td> </tr> </tbody> </table>	REV No.	ITEM	LOT No.	A	CCFL tube diameter ( $\phi 2.6 \rightarrow \phi 2.4$ )	-	B	CFL I/F Connector : Mitsumi M63M83-04 → JAE IL-G-4S-S3C2-SA
REV No.	ITEM	LOT No.								
A	CCFL tube diameter ( $\phi 2.6 \rightarrow \phi 2.4$ )	-								
B	CFL I/F Connector : Mitsumi M63M83-04 → JAE IL-G-4S-S3C2-SA	7102T								

### 3. MECHANICAL DATA

- |                       |   |
|-----------------------|---|
| (1) Part Name         | SP12N002  |
| (2) Module Size       | 160.0 (W)mm x 68.0 (H)mm x 12.0 (D)mm max.  |
| (3) Dot Size          | 0.44 (W)mm x 0.44 (H)mm   |
| (4) Dot Pitch         | 0.47 (W)mm x 0.47 (H) mm  |
| (5) Number of Dots    | 256 (W) x 64 (H) dots   |
| (6) Duty              | 1/64  |
| (7) LCD               | Film type black/white (Positive/negative type).The upper polarizer is anti-glare type.(hardness.3H) The bottom polarizer is transitive type |
| (8) Viewing Direction | 6 O'clock   |
| (9) Backlight         | Cold cathode fluorescent lamp   |
| (10) Controller       | T6963C  |
| (11) I/F Connector    | Molex : 5378-2090   |

## 4. ABSOLUTE MAXIMUM RATINGS

### 4.1 ELECTRICAL ABSOLUTE MAXIMUM RATINGS

ITEM	SYMBOL	MIN.	MAX.	UNIT	COMMENT
Power Supply for Logic	VDD-VSS	0	6.5	V	
Power Supply for LC Drive	VDD-VEE	0	20.5	V	
Input Voltage	VI	-0.3	VDD+0.3	V	
Input Current	Ii	0	1	A	
Static Electricity	-	-	-	-	(Note 1)

Note 1 : Make certain you are grounded when handling LCM

### 4.2 ENVIRONMENTAL ABSOLUTE MAXIMUM RATINGS

ITEM	OPERATING		STORAGE		COMMENT
	MIN.	MAX.	MIN.	MAX.	
Ambient Temperature	0°C	50°C	-20°C	60°C	(Note2,3)
Humidity	(Note 1)		(Note 1)		Without Condensation
Vibration	-	4.9m/s <sup>2</sup> (0.5G)	-	19.6m/s <sup>2</sup> (2G)	(Note 4)
Shock	-	29.4m/s <sup>2</sup> (3G)	-	490.0m/s <sup>2</sup> (50G)	XYZ Direction
Corrosive Gas	Not acceptable		Not acceptable		

Note 1 Ta ≤ 40°C : 85%RH max.

Ta > 40°C : Absolute humidity must be lower

Than the humidity of 85%Rh at 40°C.

Note 2 : Ta at -20°C < 48h, At 60°C ----- < 168h

Note 3 : Background color changes slightly depending on ambient temperature.

This phenomenon is reversible. Higher starting voltage of CFL and higher LCD driving voltage are needed while operating at 0°C. The life time of CFL will be reduced while operating at 0°C need to make sure of value of IL and characteristics of inverter. Also the response time at 0°C will be slower.

Note 4 : 5Hz~100Hz (Except resonance frequency)

Note 5 : This module should be operated normally after finish the test.

## 5. ELECTRICAL CHARACTERISTICS

### 5.1 ELECTRICAL CHARACTERISTICS OF LCM

ITEM	SYMBOL	CONDITION	MIN.	TYP.	MAX.	UNIT
Power Supply Voltage for Logic	VDD-VSS	-	4.75	5.0	5.25	V
LC Driver Circuit Power Supply Voltage	VEE-VSS	-	-15.5	-15.0	-14.5	V
Input Voltage	VI	H LEVEL	0.8VDD	-	VDD	V
		L LEVEL	0	-	0.2VDD	V
Power Supply Current for Logic (Note 1)	IDD	VDD-VSS=5.0V	-	11.0	14.0	mA
Power Supply Current For LCD Driving (Note 1)	IEE	VDD-VSS=5.0V	-	1.9	4.0	mA
Recommended LC Driving Voltage (Note 2)	VDD-V0	Ta=0°C, $\phi=10^\circ$	-	(16.2)	-	V
		Ta=25°C, $\phi=10^\circ$	-	(15.0)	-	V
		Ta=50°C, $\phi=10^\circ$	-	(14.3)	-	V
Frame Frequency (Note 3)	fFLM	-	-	75	-	Hz

Note 1 : fFLM=75Hz, VDD-V0=(15.0)V, Ta=25°C

Note 2 : Recommended LC driving voltage fluctuate about  $\pm 1.0V$  by each module.  
Test pattern is all "Q"

Note 3 : Need to make sure of flickering and rippling of display when setting the frame frequency in your set.

### 5.2 ELECTRICAL CHARACTERISTICS OF BACKLIGHT

ITEM	SYMBOL	MIN.	TYP.	MAX.	UNIT	NOTE
Lamp Voltage	VL	-	360	-	V	Ta=25°C
Frequency	fL	30	70	85	kHz	Ta=25°C
Lamp Current	IL	2.5	5	5.5	mA	Ta=25°C
Start Discharge Voltage	VS (Note 2)	(1000)	-	-	V	Ta=25°C

Note 1 : Please certainly inform HITACHI before designing lamp drive circuit according to the above specifications.

Note 2 : Starting discharge voltage is increased when LCM is operating at lower temperature. Please check the characteristics of inverter before applying.

Note 3 : Average life time of CFL will be decreased when LCM is operating at lower temperature.

## 6. OPTICAL CHARACTERISTICS

### 6.1 OPTICAL CHARACTERISTICS

Ta=25°C (BACKLIGHT ON)

ITEM	SYMBOL	CONDITION	MIN.	TYP.	MAX.	UNIT	NOTE
Viewing Area	$\phi 2-\phi 1$	$K \geq 2.0$	30	(40)	-	deg	1,2
Contrast Ratio	K	$\phi = 10^\circ \theta = 0^\circ$	-	20	-	-	3
Response Time (Rise)	tr	$\phi = 10^\circ \theta = 0^\circ$	-	(160)	-	ms	4
Response Time (Fall)	tf	$\phi = 10^\circ \theta = 0^\circ$	-	(110)	-	ms	4

(Measure condition by HITACHI)

Note 1 : Definition of  $\theta$  and  $\phi$

Note : 3 Definition of contrast "K"

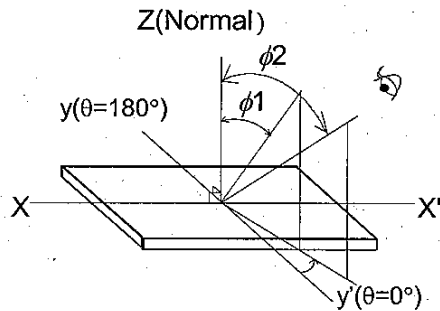

$$K = \frac{\text{Brightness on selected dot (B1)}}{\text{Brightness on non-selected dot (B2)}}$$

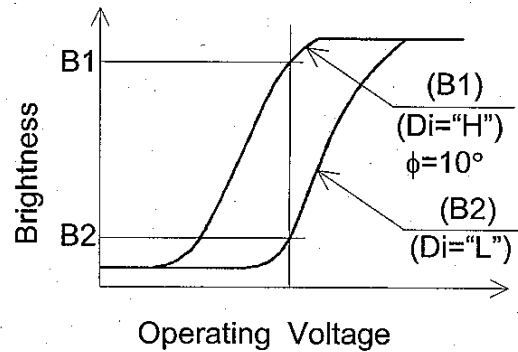

Note 2 : Definition of viewing angle  $\phi 1$  and  $\phi 2$

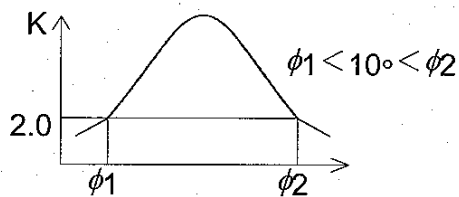

Contrast ratio K vs viewing

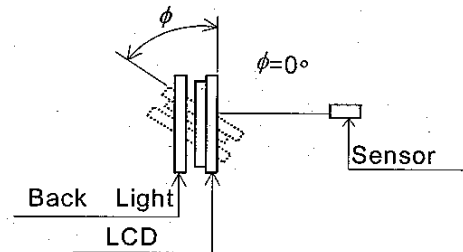

Note 4 : Definition of optical response

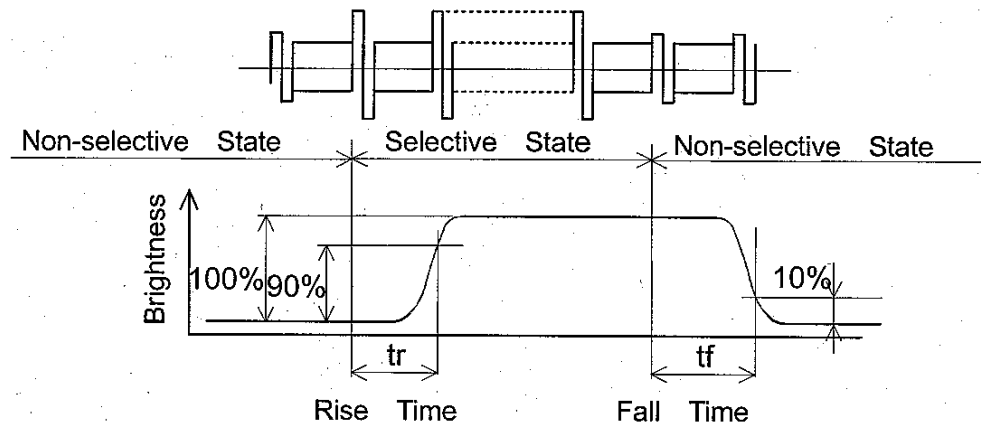

## 6.2 OPTICAL CHARACTERISTICS OF BACKLIGHT

(LCM, BACKLIGHT ON, Ta=25°C)

ITEM	MIN.	TYP.	MAX.	UNIT	NOTE
Brightness	70.0	90.0	-	cd/m <sup>2</sup>	IL=5mA (Note 1,2)
Rise Time	-	5	-	Minute	IL=5mA Brightness 80%
Brightness Uniformity	-	-	±30	%	Undermentioned (Note 1,3)

CFL : Initial Ta=25°C, VDD-V0=15.0V  
Display data should be all "ON"

Note 1 : Measurement after 10 minutes of CFL operating.

Note 2 : Brightness control : 100%.

Note 3 : Measurement of the following 9 places on the display

Definition of the brightness tolerance.

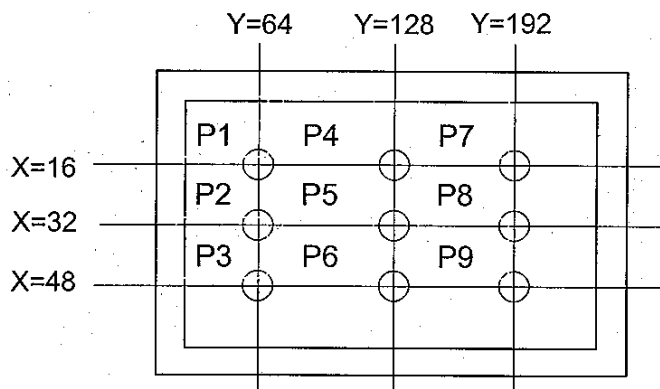

$$\left( \frac{\text{max. Brightness or min. Brightness} - \text{Average Brightness}}{\text{Average Brightness}} \right) \times 100$$

# 7. BLOCK DIAGRAM

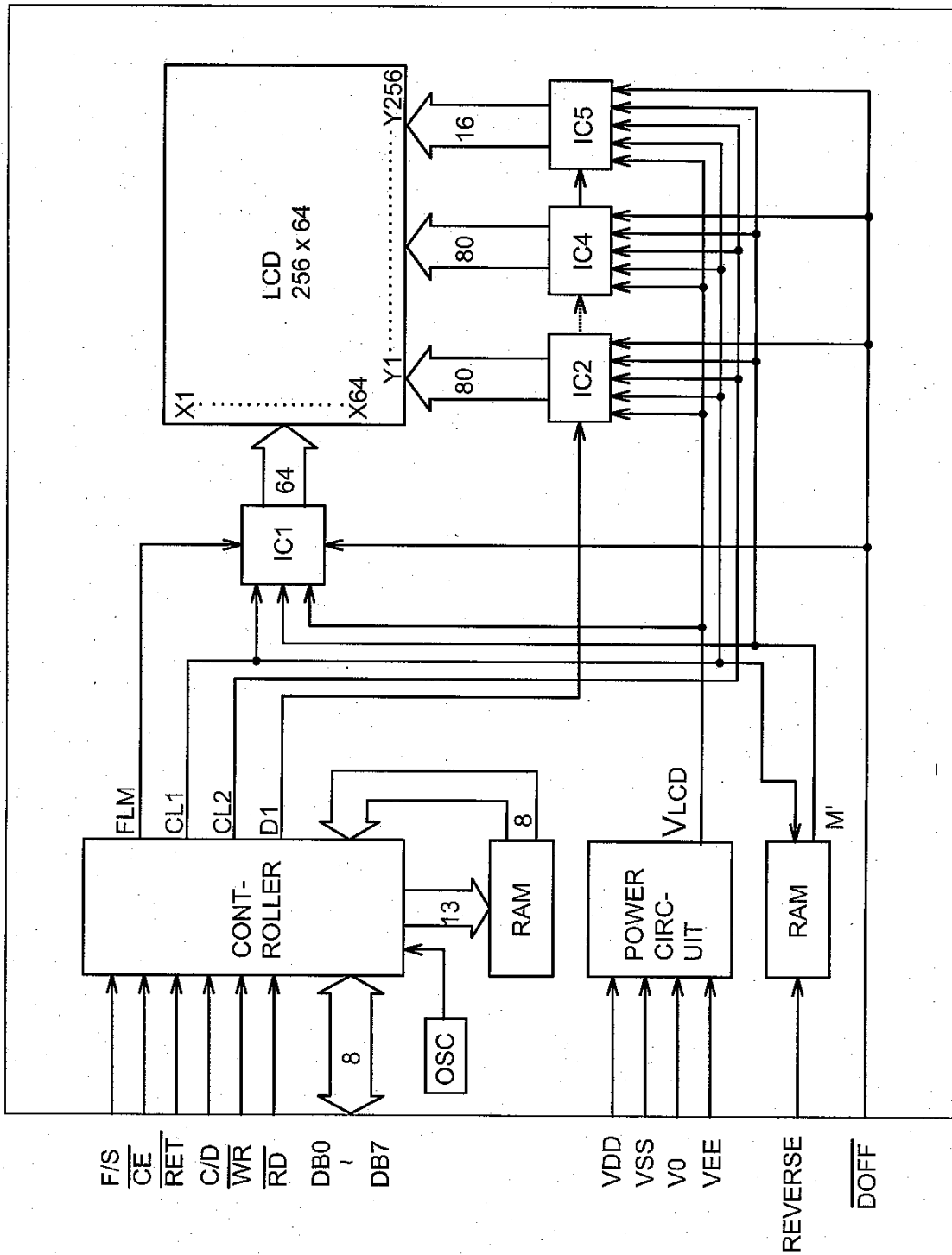



# 8. INTERFACE TIMING CHART

## 8.1 INTERFACE TIMING CHART

ITEM	SYMBOL	MIN.	TYP.	MAX.	UNIT
C/D Setup Time	tCDS	100	-	-	ns
C/D Hold Time	tCDH	10	-	-	ns
$\overline{\text{CE}}$ , $\overline{\text{RD}}$ , $\overline{\text{WR}}$ , Pulse Width	t $\overline{\text{CE}}$ , t $\overline{\text{RD}}$ , t $\overline{\text{WR}}$	80	-	-	ns
Data Setup Time	tDS	80	-	-	ns
Data Hold Time	tDH	40	-	-	ns
Access Time	tACC	-	-	150	ns
Output Hold Time	tOH	10	-	50	ns

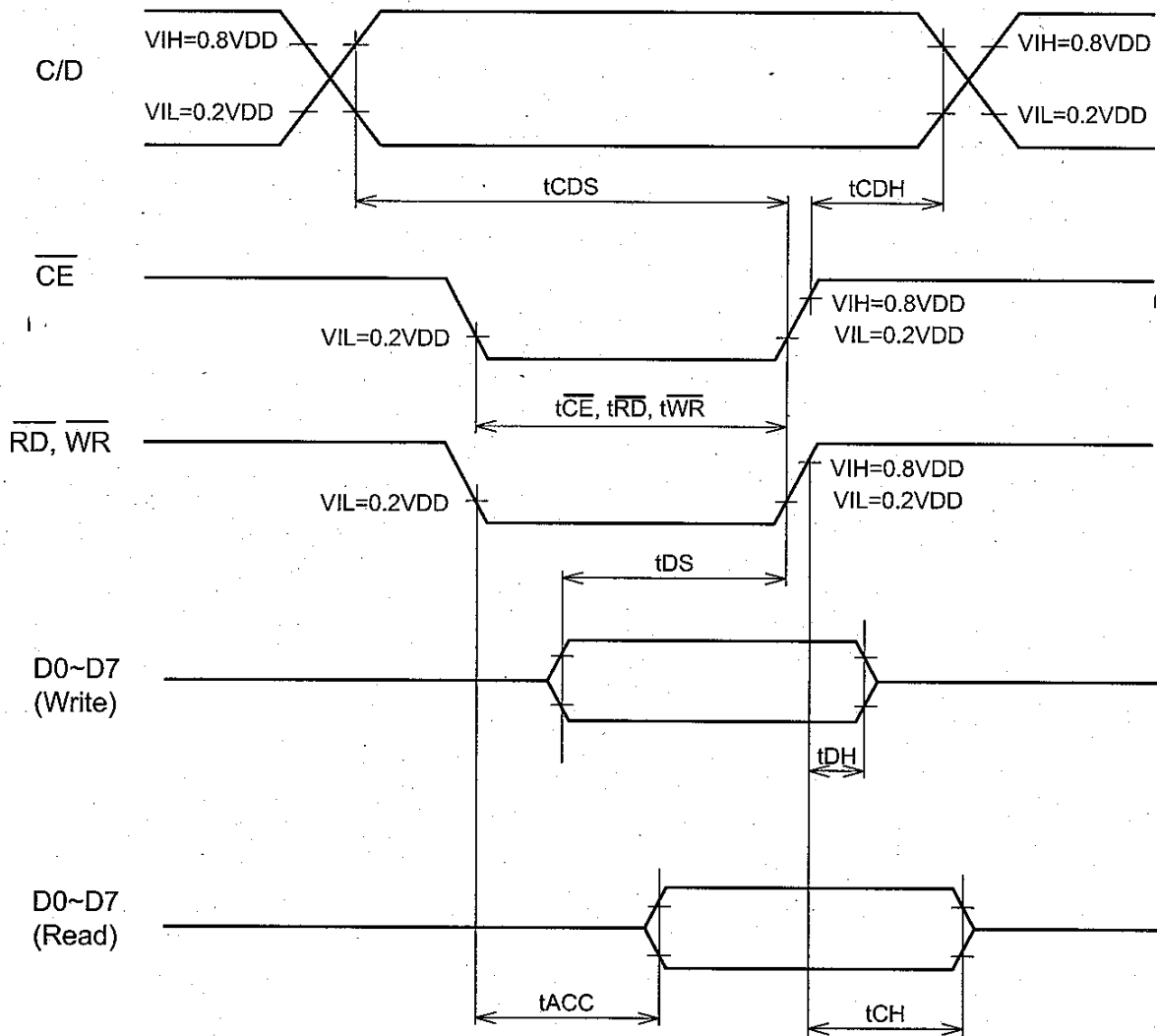

## 8.2 TIMING OF POWER SUPPLY AND INTERFACE SIGNAL

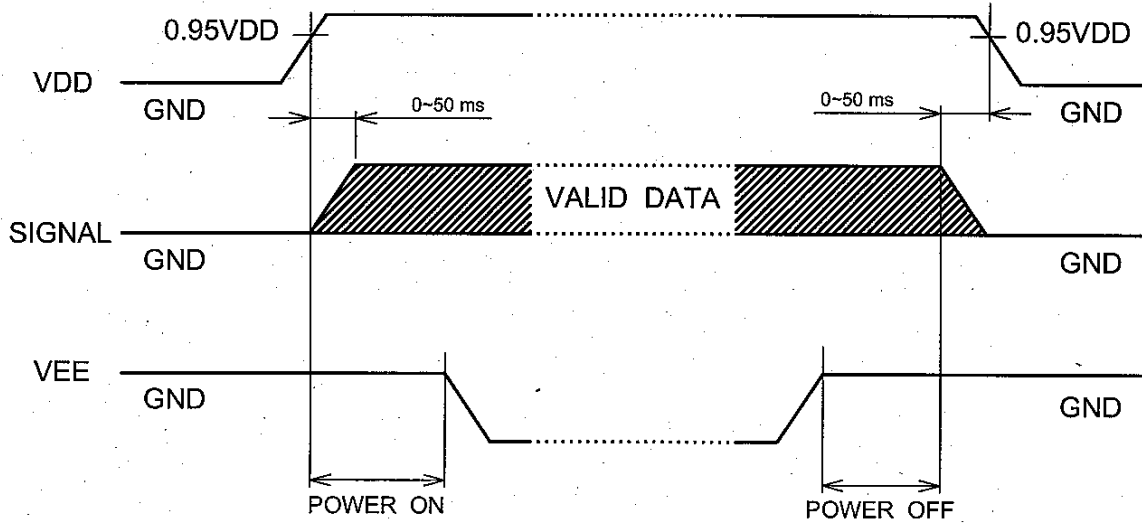

The missing pixels may occur when the LCM is driven beyond above power interface timing sequence.

## 8.3 POWER SUPPLY FOR LCM (EXMAPLE)

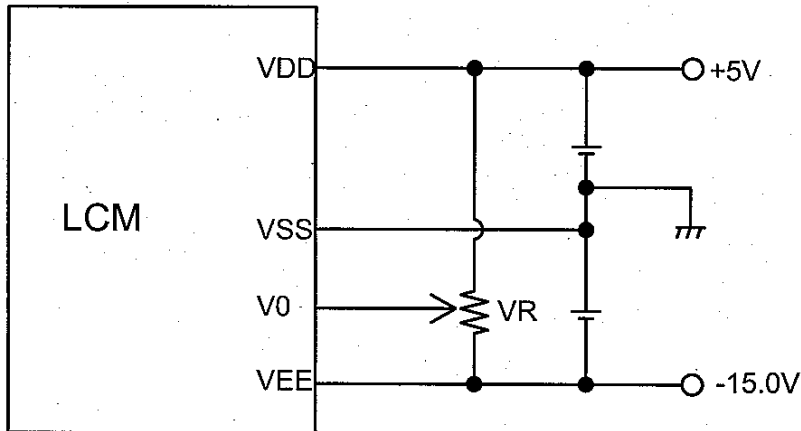

VR : 10~20k $\Omega$   
VDD-V0 : LCD Driving Voltage

9. DIMENSIONAL OUTLINE  
9.1 DIMENSIONAL OUTLINE

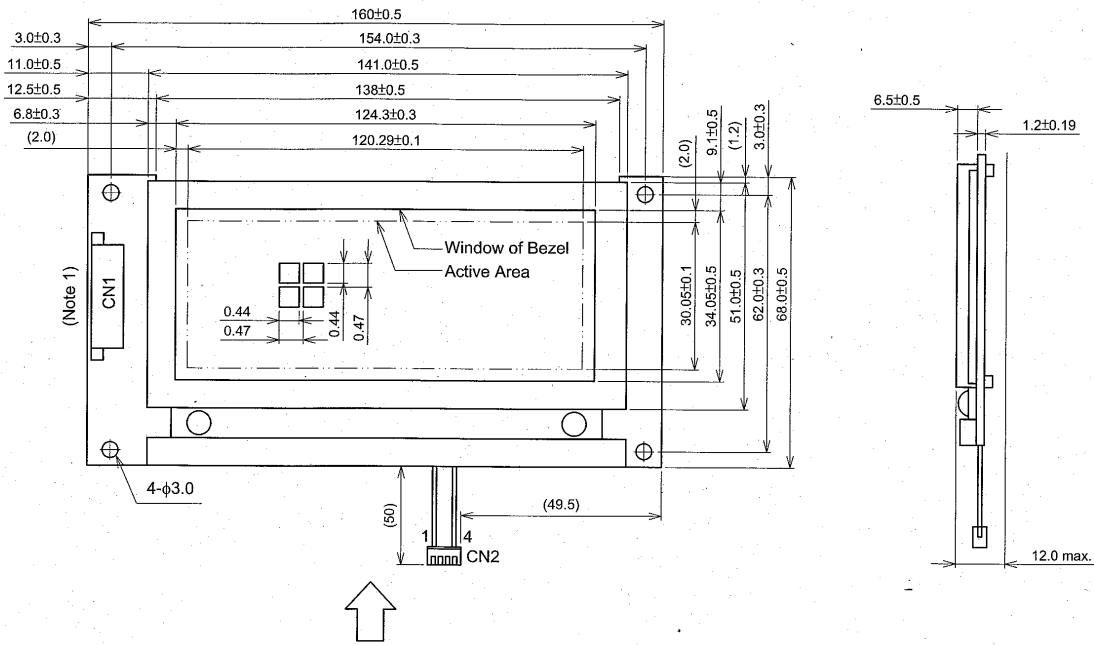

Unit : mm  
Scale : NTS

Controller : T6963C  
CFL - I/F Connector  
JAE IL-G-4S-S3C2-SA

Note 1 : Connector on the lsi side of PCB  
Type : 53780-2090 (Maker : Molex)  
Applied to : 51146-2000

Interface

A01	VSS
A02	VDD
A03	V0
A04	C/D
A05	WR
A06	RD
A07	DB0
A08	DB1
A09	DB2
A10	DB3
A11	DB4
A12	DB5
A13	DB6
A14	DB7
A15	CE
A16	RET
A17	VEE
A18	DOFF
A19	F/S
A20	REVERSE

CFL I/F

1	VCFL(-)
2	N.C
3	N.C
4	VCFL(+)

## 9.2 DISPLAY PATTERN

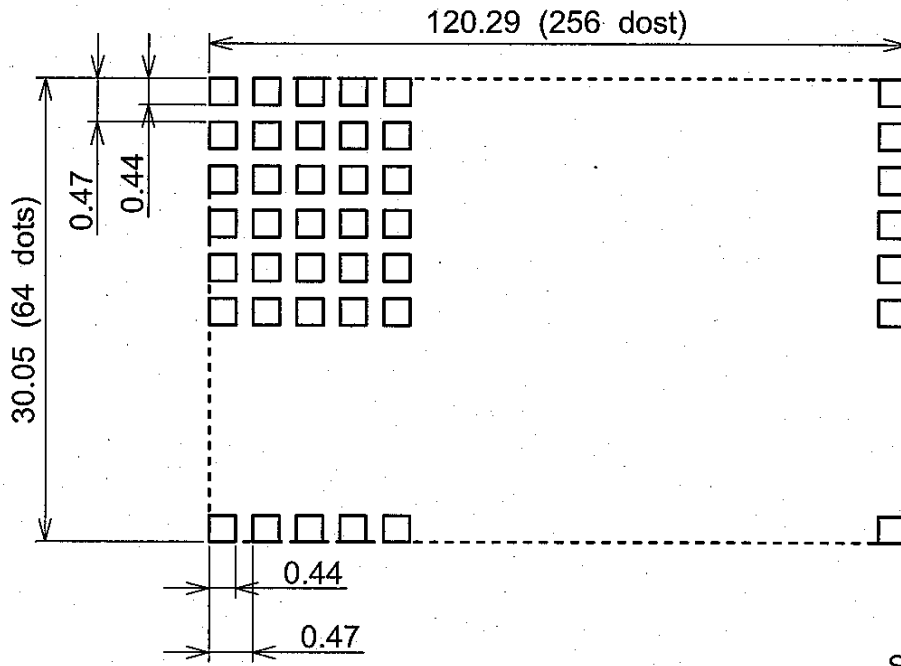

SCALE:NTS

UNIT:mm

Measurement Tolerance :  $\pm 0.1$

### 9.3 INTERFACE PIN CONNECTION

#### CN1

PIN No.	SYMBOL	Function
A1	VSS	Ground
A2	VDD	Power Supply For Logic Circuit
A3	V0	Power supply for LCD drive
A4	C/D	WR="L" : C/D="H" Command Write C/D="L" Data Write RD="L" : C/D="H" Status Read C/D="L" Data Read
A5	$\overline{WR}$	Data Write (Data write at "L")
A6	$\overline{RD}$	Data Read (Data read at "L")
A7~A14	DB0~DB7	Data Bus
A15	$\overline{CE}$	Chip Enable (CE must be "L")
A16	$\overline{RET}$	Reset
A17	VEE	Power Supply for LCD Drive
A18	$\overline{DOFF}$	Hi/display On, GND/Display Off
A19	F/S	Character Font Select : F/S="H" → 6 x 8 Font F/S="L" → 8 x 8 Font
A20	Reverse	Display Mode Reverse

#### CN2

INTERFACE	PIN No.	SYMBOL	LEVEL	FUNCTION	
CFL	CFL I/F	1	CFL(-)	-	Power Supply for CFL(-)
		2	N.C	-	-
		3	N.C	-	-
		4	VCFL(+)	-	Power Supply for CFL(+)

CFL I/F : JAE IL-G-4S-S3C2-SA

## 10. APPEARANCE STANDARD

### 10.1 APPEARANCE INSPECTION CONDITION

Visual inspection should be done under the following condition.

- (1) In the dark room.
- (2) With CFL panel lighted with prescribed inverter circuit.
- (3) With eyes 25 cm distance from LCM.
- (4) Viewing angle within  $45^\circ$  from the vertical line to the center of LCD.

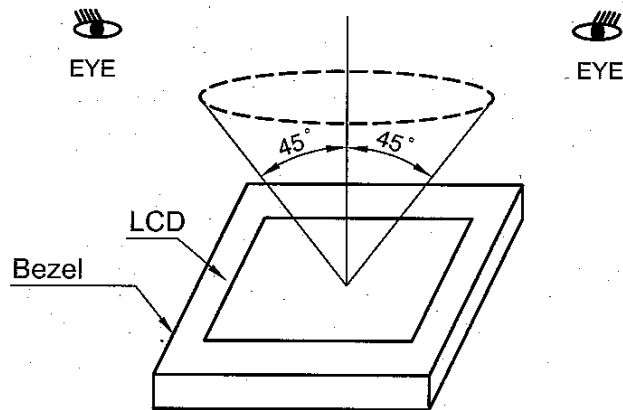

### 10.2 DEFINITION OF EACH ZONE

A zone : Within the active area specified at page 9-1/3 of this document.

B zone : Area between the window of bezel line and the active area line specified at page 9-1/3 of this document.

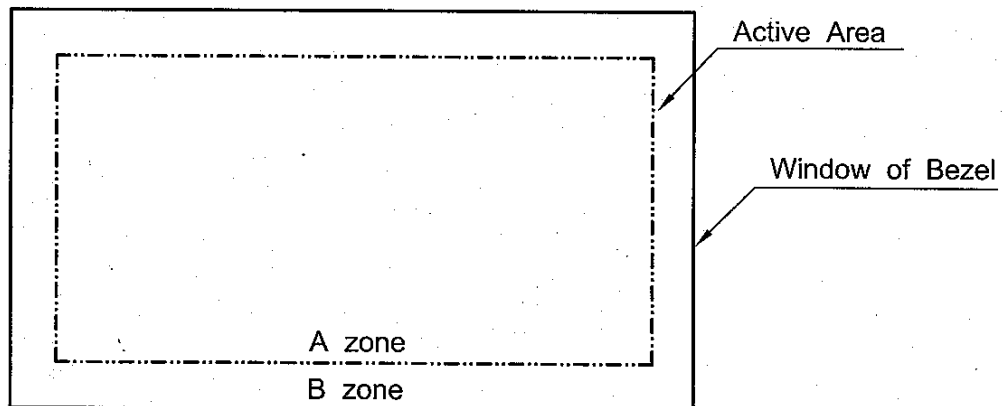

### 10.3 APPEARENCE SPECIFICATION

#### (1) LCD APPEARANCE

\* If the problem related to this section occurs about this item, the responsible persons of both party (Customer and HITACHI) will discuss the matter in detail.

No.	ITEM	CRITERIA		A	B	
L C D	Scratches	Distinguished one is not acceptable (To be judged by HITACHI standard)		※	-	
	Dent	Same as above		※	-	
	Wrinkles in Polarizer	Same as above		※	-	
	Bubbles	Average diameter D(mm)	Max. Number acceptable		O	-
		$D \leq 0.2$	Ignore			
		$0.2 < D \leq 0.3$	12			
		$0.3 < D \leq 0.5$	3			
		$0.5 < D$	None			
	Stains,	Filamentous			O	-
	Foreign Materials Dark Spot	Length L(mm)	Width W(mm)	Max. number acceptable		
		$L \leq 2.0$	$W \leq 0.03$	Ignore		
		$L \leq 3.0$	$0.03 < W \leq 0.05$	6		
		-	$0.05 < W$	None		
		Round			O	-
		Average diameter D(mm)	Max. number acceptable	Min. space		
		$D < 0.2$	Ignore	-		
		$0.2 \leq D < 0.3$	6	10 mm		
		$0.3 \leq D < 0.4$	4	30 mm		
		$0.4 \leq D$	None	-		
		The whole number	Filamentous+Round=5			
		Color Tone	Those wiped out easily are acceptable		O	O
		Color Uniformity	To be judged by HITACHI standard		O	-
			Same as above		O	-
	$(A+B)/2 \leq 0.15$ MAX. number : Ignored					
	Pinhole	$0.15 < (A+B)/2 \leq 0.3$ MAX. number : Ignored		O	-	
		$C \leq 0.03$ MAX. number : Ignored				

No.	ITEM	CRITERIA				A	B
L	Contrast Irregularity (Spot)	Average diameter D(mm)	Contrast	Maximum number acceptable	Minimum space	O	-
		$D \leq 0.25$	To be	ignored	-		
		$0.25 < D \leq 0.35$	Judge by HITACHI Standard	10	20mm		
		$0.35 < D \leq 0.5$		4	20mm		
		$0.5 < D$		None	-		
C D	Contrast Irregularity (A pair of scratches)	Length L(mm)	Width W(mm)	Maximum Number acceptable	Minimum space	O	-
		$L \leq 1.2$	$W \leq 0.25$	2	20mm		
		$L \leq 0.15$	$W \leq 0.2$	3	20mm		
		$L \leq 0.2$	$W \leq 0.15$	3	20mm		
		$L \leq 0.3$	$W \leq 0.1$	4	20mm		
		The whole number	6				
		The whole		6			
Rubbing Scratch		To be judged by HITACHI standard					



(2) CFL BACKLIGHT APPEARANCE

No.	ITEM	CRITERIA			A	B		
C F L  B A C K L I G H T	Dark Spots Irregularity Foreign (Spot)	Average diameter D (mm)		Maximum number acceptable	O	-		
		$D \leq 0.4$		Ignored				
		$0.4 < D$		None				
	Foreign Materials  (Line)	Length L (mm)	Width W (mm)	Maximum number acceptable		O	-	
		$L \leq 2.5$	Width W(mm)	1				
		$2.5 < L$		None				
		-	$0.2 < W$	None				
		Scratches	Length L(mm)	Width W(mm)	Maximum number acceptable		O	-
			-	$W \leq 0.1$	Ignored			
			$L \leq 11.0$	$0.1 < W \leq 0.2$	1			
	$11.0 < L$		None					
	-	$0.2 < W$	None					

Note

(1) Definition of average diameter D

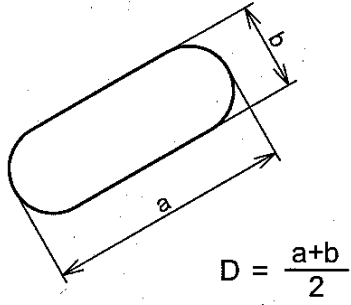

(2) Definition of length L and width W

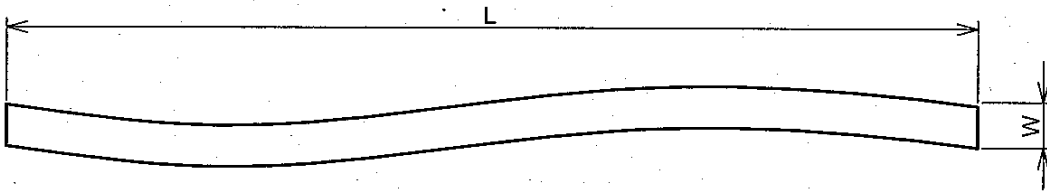

(3) Definition of pinhole

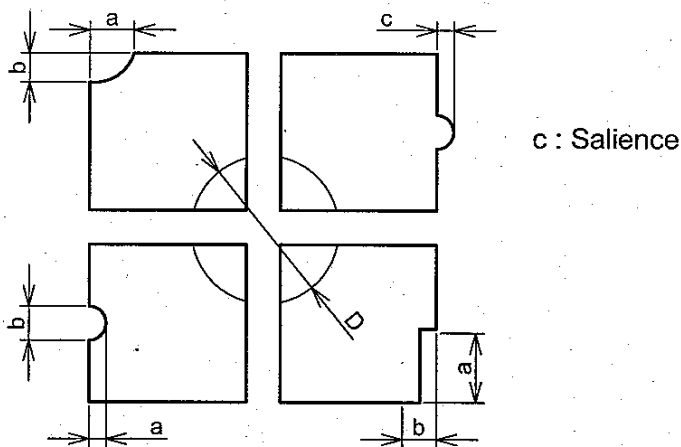

# 11. PRECAUTION IN DESIGN

## 11.1 MOUNTING METHOD

Since the module is so constructed as to be fixed by utilizing fitting holes in the module as shown below, it is necessary to take consideration the following items on attachment to a frame.

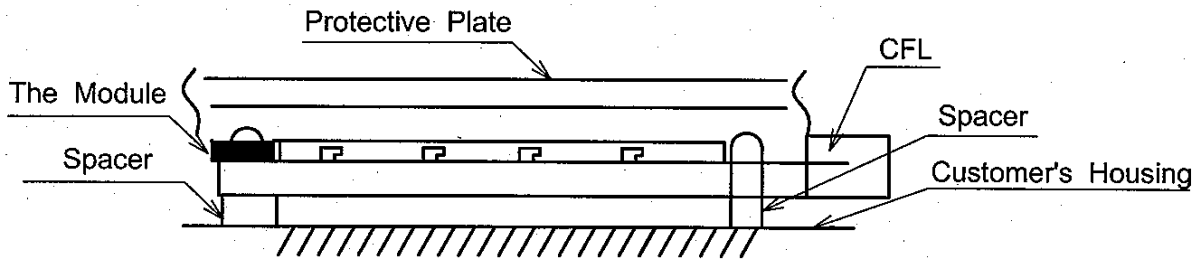

Example of Mounting

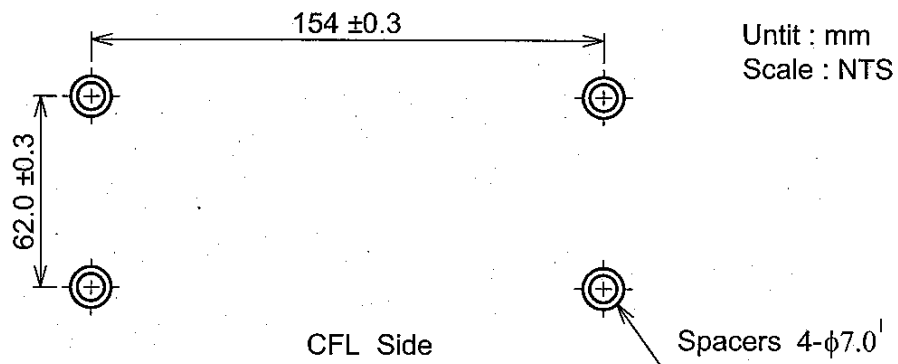

Location of Spacers

- (1) Use of protective plate, Made of an acrylic plate, etc, in order to protect a polarizer and LC cell.
- (2) To prevent the module cover from being pressed, the spacers between the module and the fitting.
- (3) We recommend you to use protective spacer as figure for protecting LCD module from any kind of shock to your set.

## 11.2 LC DRIVING VOLTAGE (V0) AND VIEWING ANGLE RANGE

Setting V0 out of the recommended condition will be a cause for a change of viewing angle range.

### 11.3 CAUTION AGAINST STATIC CHANGE

As this module is provided with C-MOS LSIs, the care to take such a precaution as to grounding the operator's body is required when handling it.

### 11.4 POWER ON SEQUENCE

Input signals should not be applied to LCD module before power supply voltage is applied and reaches to specified voltage ( $5 \pm 0.25V$ ). If above sequence is not kept, C-MOS LSIs of LCD modules may be damaged due to latch up problem.

### 11.5 PACKAGING

- (1) No. Leaving products is preferable in the place of storage in the place where high humidity for a long period of time. For their temperature is  $35^{\circ}C$  or higher, special care to prevent them from high humidity is required. A combination of high temperature and high humidity may cause them polarization degradation as well as bubble generation and polarizer peel-off.  
Please keep the temperature and humidity within the specified range for use and storing.
- (2) Since upper polarizers and lower aluminum plates tend to be easily damaged, they should be handled with full care so as not to get them touched, pushed or rubbed by a piece of glass. Tweezers and anything else which are harder than a pencil lead 3H.
- (3) As the adhesives used for adhering upper/lower polarizers and aluminum plates are made of organic substances which will be deteriorated by a chemical reaction with such chemicals as acetone, Toulon ethanol and isopropylalcohol.  
The following solvents are recommended for use:  
NORMAL HEXANE

Please contact with us when it is necessary for you to use chemicals other than the above.

- (4) Lightly wipe to clean the dirty surface with absorbent cotton waste or other soft material like chamois, soaked in the chemicals recommended without scrubbing it hardly. To prevent the display surface from damage and keep the appearance in good state, it is sufficient, in general, to wipe it with absorbent cotton.
- (5) Immediately wipe off saliva or water drop attached on the display area because its long period adherence may cause deformation or faded color on the spot.
- (6) Foggy dew deposited on the surface and contact terminals due to godliness will be a cause for polarizer damage, stain and dirt on product. When necessary to take out the products from some place at low temperature for test, etc. It is required for them to be warmed up in a container once at the temperature higher than that of room.
- (7) Touching the display area and contact terminals with bare hands and contaminating them are prohibited, because the stain on the display area and poor insulation between terminals are often caused by being touched by bare hands.  
(There are some cosmetics detrimental to polarizers.)
- (8) In general the quality of glass is fragile so that it tends to be cracked or chipped in handling, specially on its periphery. Please be careful not to give it sharp shock caused by dripping down, etc.

KAOHSIUNG HITACHI ELECTRONICS CO.,LTD.	DATE	May.28,'07	Sh. No.	7B64PS 2711-SP12N002-3	PAGE	11-2/3
---	------	------------	------------	------------------------	------	--------

## 11.6 CAUTION FOR OPERATION

- (1) It is an indispensable condition to drive LCD's within the specified voltage limit since the higher voltage than the limit causes the shorter LCD life.  
An electrochemical reaction due to direct current causes LCD's undesirable deterioration, so that the use of direct current driver should be avoided.
- (2) Response time will be extremely delayed at lower temperature than the operating temperature range and on the other hand at higher temperature LCD's show dark blue color in them. However those phenomena do not mean malfunction or out of order with LCD's which will come back in the specified operating temperature range.
- (3) If the display area is pushed hard during operation, some font will be abnormally displayed but it resumes normal condition after turning off once.
- (3) A light dew depositing on terminals is a cause for electrochemical reaction resulting in terminal open circuit. Usage under the relative condition of 40°C 50%RH or less is required.

## 11.7 STORAGE

In cas of storing for a long period of time (For instance, for years) for the purpose of replacement use, the following ways are recommended.

- (1) Storage in a polyethylene bag with the opening sealed so as not to enter fresh air outside in it, and with no desiccant.
- (2) Placing in a dark place where neither exposure to direct sunlight nor light is, keeping temperature in the range from 0°C to 35°C.
- (3) Storing with no touch on polarizer surface by anything else.  
(It is recommended to store them as they have been contained in the inner container at the time of delivery from us.)

## 11.8 SAFETY

- (1) It is recommendable to crash damaged or unnecessary LCD's into pieces and wash off liquid crystal by either of solvents such as acetone and ethanol, which should be burned up later.
- (2) When any liquid leaked out of a damaged glass cell comes in contact with your hands, please wash it off well with soap and water.

KAOHSIUNG HITACHI ELECTRONICS CO.,LTD.	DATE	May.28,'07	Sh. No.	7B64PS 2711-SP12N002-3	PAGE	11-3/3
---	------	------------	------------	------------------------	------	--------

## 12. DESIGNATION OF LOT MARK

### 12.1 LOT MARK

Lot mark is consisted of 4 digits for production lot.

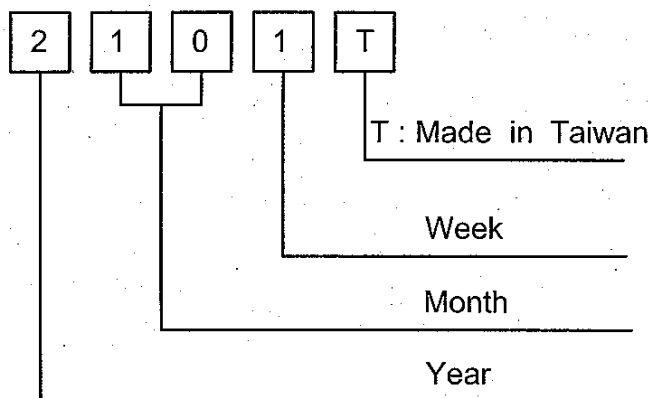

YEAR	FIGURE IN LOT MARK
2007	7
2008	8
2009	9
2010	0

MONTH	FIGURE IN LOT MARK	MONTH	FIGURE IN LOT MARK
Jan.	01	Jul.	07
Feb.	02	Aug.	08
Mar.	03	Sep.	09
Apr.	04	Oct.	10
May	05	Nov.	11
Jun.	06	Dec.	12

WEEK (DAY IN CALENDAR)	FIGURE IN LOT MARK
1~7	1
8~14	2
15~21	3
22~28	4
29~31	5

### 12.2 REVISION

REV No.	ITEM	LOT No.
A	CCFL tube diameter ( $\phi 2.6 \phi 2.4$ )	-
B	CFL I/F Connector : Mitsumi M63M83-04 → JAE IL-G-4S-S3C2-SA	7102T

12.3 Location of lot mark : On the back side of LCM

2101T

### 13. PRECAUTION FOR USE

(1) A limited sample should be provided by the both parties on an occasion when the both parties agreed its necessity.

Judgement by a limit sample shall take effect after the limited sample has established and confirmed by the both parties.

(2) In the following occasion, the handling of the problem should be decided through discussion and agreement between responsible persons of the both parties.

(1) When a question is arisen in the specifications.

(2) When a new problem is arisen that is not specified in this specifications.

(3) When an inspection specifications change or operating condition change in customer is reported to HITACHI, and some problems are arisen in this specification due to the change.

(4) When a new problem is arisen at the customer's operating set for sample evaluation in the customer side.

(3) Regarding the treatment for maintenance and repairing, both parties will discuss it in six months later after latest delivery of this product.

The precaution that should be observed when handling LCM has been explained above. If any points are unclear or if you have any requests, please contact with HITACHI.

KAOHSIUNG HITACHI ELECTRONICS CO.,LTD.	DATE	May.28,'07	Sh. No.	7B64PS 2713-SP12N002-3	PAGE	13-1/1
---	------	------------	------------	------------------------	------	--------