

# LM2991

## Negative Low Dropout Adjustable Regulator

### General Description

The LM2991 is a low dropout adjustable negative regulator with a output voltage range between -3V to -24V. The LM2991 provides up to 1A of load current and features a  $\overline{\text{ON}}$  /Off pin for remote shutdown capability.

The LM2991 uses new circuit design techniques to provide a low dropout voltage, low quiescent current and low temperature coefficient precision reference. The dropout voltage at 1A load current is typically 0.6V and a guaranteed worst-case maximum of 1V over the entire operating temperature range. The quiescent current is typically 1 mA with a 1A load current and an input-output voltage differential greater than 3V. A unique circuit design of the internal bias supply limits the quiescent current to only 9 mA (typical) when the regulator is in the dropout mode ( $V_{\text{OUT}} - V_{\text{IN}} \leq 3\text{V}$ ).

The LM2991 is short-circuit proof, and thermal shutdown includes hysteresis to enhance the reliability of the device when inadvertently overloaded for extended periods. The LM2991 is available in 5-lead TO-220 and TO-263 packages and is rated for operation over the automotive temperature range of -40°C to +125°C. Mil-Aero versions are also available.

### Features

- Output voltage adjustable from -3V to -24V, typically -2V to -25V
- Output current in excess of 1A
- Dropout voltage typically 0.6V at 1A load
- Low quiescent current
- Internal short circuit current limit
- Internal thermal shutdown with hysteresis
- TTL, CMOS compatible  $\overline{\text{ON}}$ /OFF switch
- Functional complement to the LM2941 series

### Applications

- Post switcher regulator
- Local, on-card, regulation
- Battery operated equipment

### Typical Application

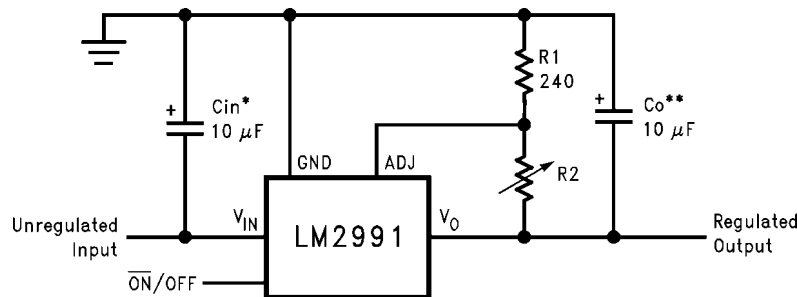

1126001

$$V_{\text{OUT}} = V_{\text{REF}} (1 + R2/R1)$$

\*Required if the regulator is located further than 6 inches from the power supply filter capacitors. A 1 μF solid tantalum or a 10 μF aluminum electrolytic capacitor is recommended.

\*\*Required for stability. Must be at least a 10 μF aluminum electrolytic or a 1 μF solid tantalum to maintain stability. May be increased without bound to maintain regulation during transients. Locate the capacitor as close as possible to the regulator. The equivalent series resistance (ESR) is critical, and should be less than 10Ω over the same operating temperature range as the regulator.

## Connection Diagrams

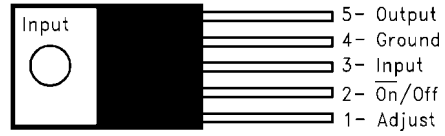

1126009

**Front View**  
**TO-220, 5-Lead, Straight**  
 See NS Package Number T05A

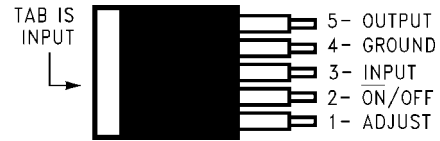

1126011

**Top View**  
**TO263, 5-Lead, Surface-Mount**  
 See NS Package TS5B

## Ordering Information

Order Number	Package Type	NSC Package	Package Marking	Supplied As
LM2991S	5-Lead TO-263	TS5B	LM2991S	Rail of 45
LM2991SX	5-Lead TO-263	TS5B	LM2991S	Reel of 500
LM2991T	5-Pin TO-220	T05A	LM2991T	Rail of 45

## Absolute Maximum Ratings *(Note 1)*

If Military/Aerospace specified devices are required, please contact the National Semiconductor Sales Office/Distributors for availability and specifications.

Input Voltage	-26V to +0.3V
ESD Susceptibility <i>(Note 2)</i>	2 kV
Power Dissipation <i>(Note 3)</i>	Internally limited
Storage Temperature Range	-65°C to +150°C
Lead Temperature (Soldering, 10 sec.)	230°C

## Operating Ratings *(Note 1)*

Junction Temperature Range ( $T_J$ )	-40°C to +125°C
$\overline{\text{ON}}$ /OFF Pin	0V to +5V
Maximum Input Voltage (Operational)	-26V

## Electrical Characteristics

$V_{IN} = -10V$ ,  $V_O = -3V$ ,  $I_O = 1A$ ,  $C_O = 47 \mu F$ ,  $R1 = 2.7 k\Omega$ ,  $T_J = 25^\circ C$ , unless otherwise specified. **Boldface** limits apply over the entire operating junction temperature range.

Parameter	Conditions	Typical <i>(Note 4)</i>	Min	Max	Units
Reference Voltage	$5 \text{ mA} \leq I_O \leq 1 \text{ A}$	-1.210	-1.234	-1.186	V
	$5 \text{ mA} \leq I_O \leq 1 \text{ A}$ , $V_O - 1V \geq V_{IN} \geq -26V$		<b>-1.27</b>	<b>-1.15</b>	
Output Voltage Range		-2		-3	V
	$V_{IN} = -26V$	-25	-24		
Line Regulation	$I_O = 5 \text{ mA}$ , $V_O - 1V \geq V_{IN} \geq -26V$	0.004		0.04	%/V
Load Regulation	$50 \text{ mA} \leq I_O \leq 1 \text{ A}$	0.04		0.4	%
Dropout Voltage	$I_O = 0.1 \text{ A}$ , $\Delta V_O \leq 100 \text{ mV}$	0.1		0.2 <b>0.3</b>	V
	$I_O = 1 \text{ A}$ , $\Delta V_O \leq 100 \text{ mV}$	0.6		0.8 <b>1</b>	V
Quiescent Current	$I_O \leq 1 \text{ A}$	0.7		<b>5</b>	mA
Dropout Quiescent Current	$V_{IN} = V_O$ , $I_O \leq 1 \text{ A}$	16		50	mA
Ripple Rejection	$V_{\text{ripple}} = 1 \text{ V}_{\text{rms}}$ , $f_{\text{ripple}} = 1 \text{ kHz}$ , $I_O = 5 \text{ mA}$	60	50		dB
Output Noise	10 Hz – 100 kHz, $I_O = 5 \text{ mA}$	200		450	$\mu V$
$\overline{\text{ON}}$ /OFF Input Voltage	( $V_{OUT}$ : ON)	1.2		<b>0.8</b>	V
	( $V_{OUT}$ : OFF)	1.3	<b>2.4</b>		
$\overline{\text{ON}}$ /OFF Input Current	$V_{\overline{\text{ON}}/\text{OFF}} = 0.8V$ ( $V_{OUT}$ : ON)	0.1		10	$\mu A$
	$V_{\overline{\text{ON}}/\text{OFF}} = 2.4V$ ( $V_{OUT}$ : OFF)	40		100	
Output Leakage Current	$V_{IN} = -26V$ , $V_{\overline{\text{ON}}/\text{OFF}} = 2.4V$ , $V_{OUT} = 0V$	60		250	$\mu A$
Current Limit	$V_{OUT} = 0V$	2	1.5		A

**Note 1:** Absolute Maximum Ratings indicate limits beyond which damage to the device may occur. Operating Ratings indicate conditions for which the device is intended to be functional, but do not guarantee specific performance limits. For guaranteed specifications and test conditions, see the Electrical Characteristics.

**Note 2:** Human body model, 100 pF discharged through a 1.5 k $\Omega$  resistor.

**Note 3:** The maximum allowable power dissipation is a function of the maximum operating junction temperature ( $T_{J(\text{MAX})}$ ), the thermal resistance of the package ( $\theta_{JA}$ ), and the ambient temperature ( $T_A$ ). The maximum allowable power dissipation is:  $P_D = (T_{J(\text{MAX})} - T_A)/\theta_{JA}$ , where  $T_{J(\text{MAX})}$  is 125°C, and  $T_A$  is the maximum expected ambient temperature. If this dissipation is exceeded, the die temperature will rise above 125°C. Excessive power dissipation will cause the LM2991 to go into thermal shutdown (See [THERMAL SHUTDOWN](#)). For the LM2991, the junction-to-ambient thermal resistance is 53°C/W for the TO-220, 73°C/W for the TO-263, and junction-to-case thermal resistance is 3°C/W. If the TO-263 package is used, the thermal resistance can be reduced by increasing the PC board copper area thermally connected to the package. Using 0.5 square inches of copper area,  $\theta_{JA}$  is 50°C/W; with 1 square inch of copper area,  $\theta_{JA}$  is 37°C/W; and with 1.6 or more square inches of copper area,  $\theta_{JA}$  is 32°C/W.

**Note 4:** Typicals are at  $T_J = 25^\circ C$  and represent the most likely parametric norm.

## Typical Performance Characteristics

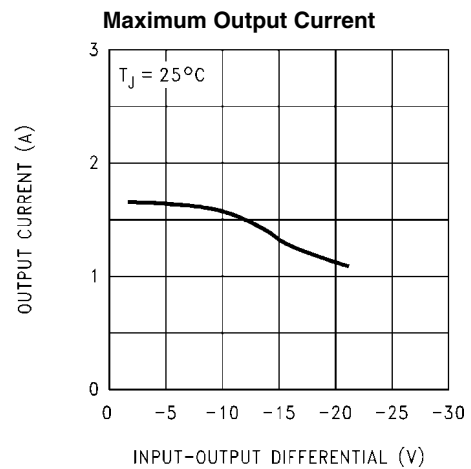
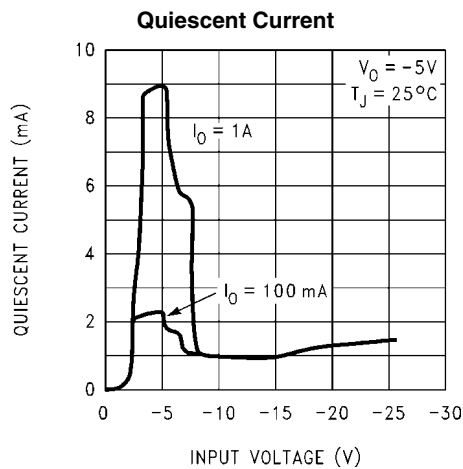
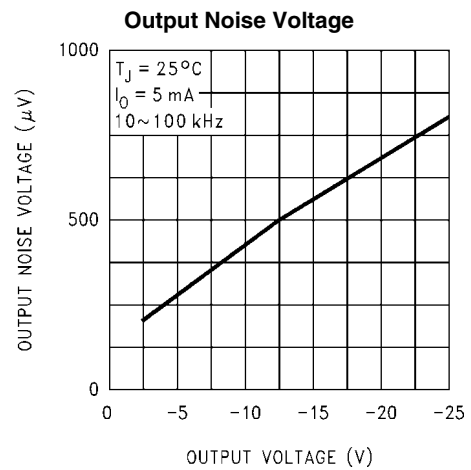
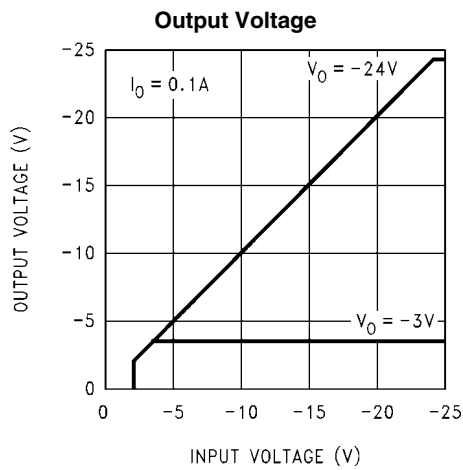
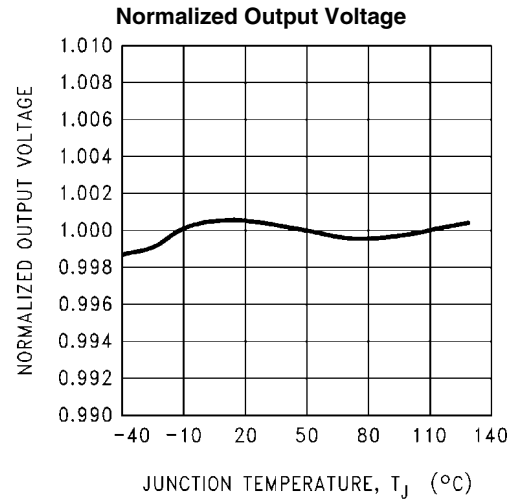
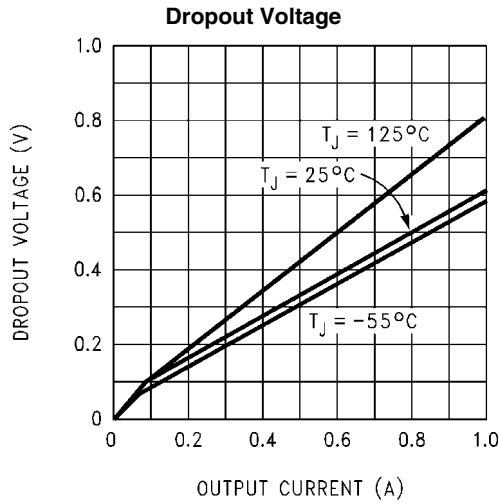

**Line Transient Response**

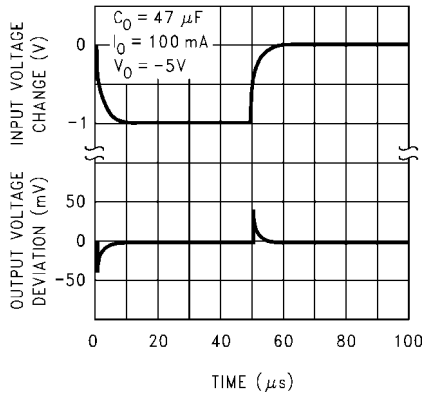

1126019

**Load Transient Response**

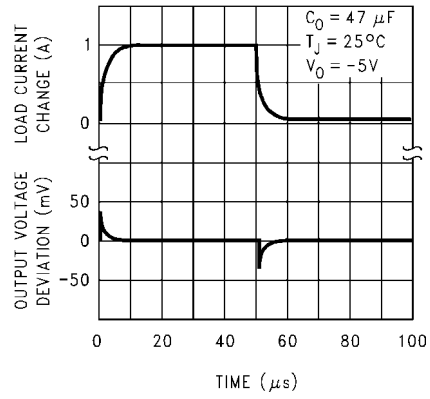

1126020

**Maximum Output Current**

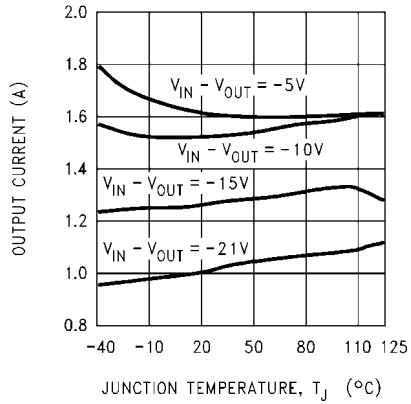

1126021

**Ripple Rejection**

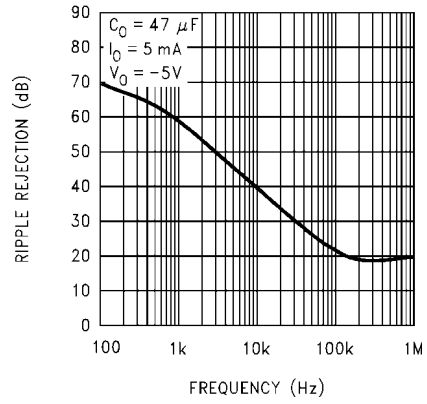

1126022

**Output Impedance**

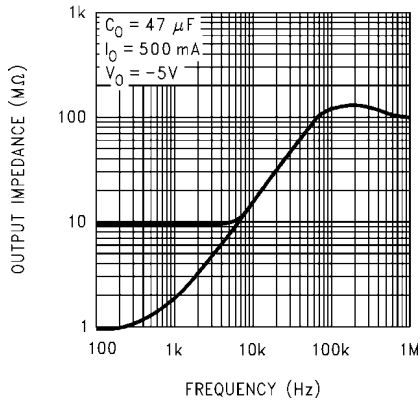

1126023

**$\overline{\text{ON}}$  /OFF Control Voltage**

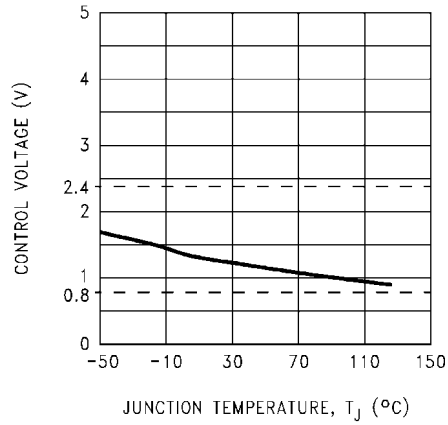

1126024

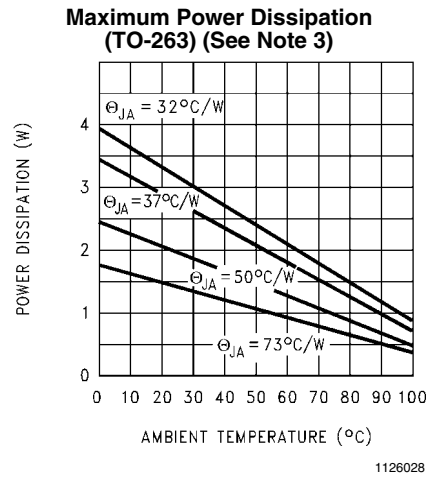
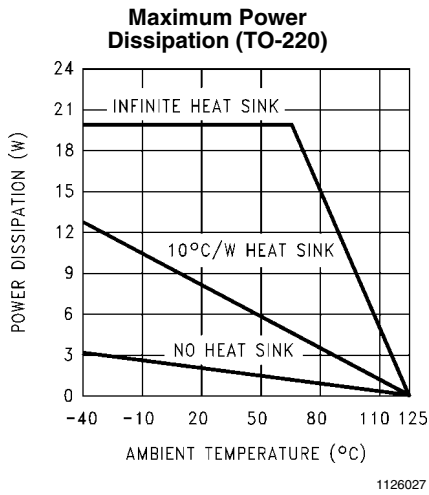
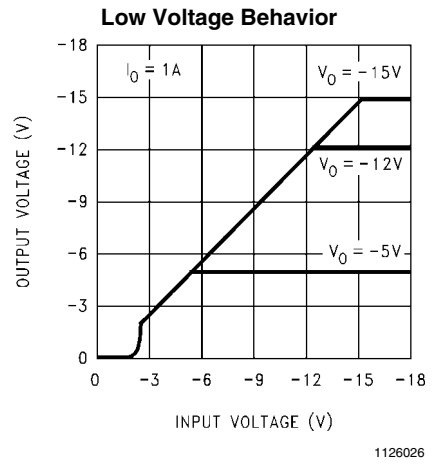
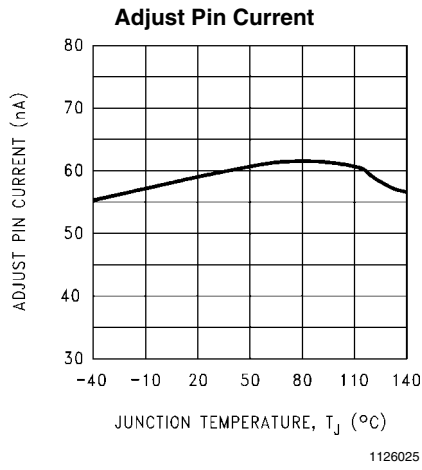

## Application Hints

### EXTERNAL CAPACITORS

Like any low-dropout regulator, external capacitors are required to stabilize the control loop. These capacitors must be correctly selected for proper performance.

### INPUT CAPACITOR

An input capacitor is required if the regulator is located more than 6 inches from the input power supply filter capacitor (or if no other input capacitor is present).

A solid Tantalum or ceramic capacitor whose value is at least 1  $\mu\text{F}$  is recommended, but an aluminum electrolytic ( $\geq 10 \mu\text{F}$ ) may be used. However, aluminum electrolytic types should not be used in applications where the ambient temperature can drop below 0°C because their internal impedance increases significantly at cold temperatures.

### OUTPUT CAPACITOR

The output capacitor must meet the ESR limits shown in *Figure 1*, which means it must have an ESR between about 25 m $\Omega$  and 10 $\Omega$ .

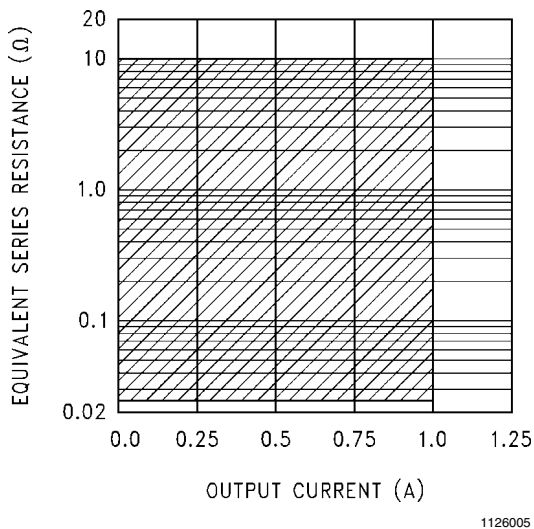

**FIGURE 1. Output Capacitor ESR Range**

A solid Tantalum (value  $\geq 1 \mu\text{F}$ ) is the best choice for the output capacitor. An aluminum electrolytic ( $\geq 10 \mu\text{F}$ ) may be used if the ESR is in the stable range.

It should be noted that the ESR of a typical aluminum electrolytic will increase by as much as 50X as the temperature is reduced from 25°C down to -40°C, while a Tantalum will exhibit an ESR increase of about 2X over the same range. For this and other reasons, aluminum electrolytics should not be used in applications where low operating temperatures occur.

The lower stable ESR limit of 25 m $\Omega$  means that ceramic capacitors can not be used directly on the output of an LDO. A ceramic ( $\geq 2.2 \mu\text{F}$ ) can be used on the output if some external resistance is placed in series with it (1 $\Omega$  recommended). Dielectric types X7R or X5R must be used if the temperature range of the application varies more than  $\pm 25^\circ$  from ambient to assure the amount of capacitance is sufficient.

### CERAMIC BYPASS CAPACITORS

Many designers place distributed ceramic capacitors whose value is in the range of 1000 pF to 0.1  $\mu\text{F}$  at the power input pins of the IC's across a circuit board. These can cause reduced phase margin or oscillations in LDO regulators.

The advent of multi-layer boards with dedicated power and ground planes has removed the trace inductance that (previously) provided the necessary "de-coupling" to shield the output of the LDO from the effects of bypass capacitors.

These capacitors should be avoided if possible, and kept as far away from the LDO output as is practical.

### MINIMUM LOAD

A minimum load current of 500  $\mu\text{A}$  is required for proper operation. The external resistor divider can provide the minimum load, with the resistor from the adjust pin to ground set to 2.4 k $\Omega$ .

### SETTING THE OUTPUT VOLTAGE

The output voltage of the LM2991 is set externally by a resistor divider using the following equation:

$$V_{\text{OUT}} = V_{\text{REF}} \times (1 + R_2/R_1) - (I_{\text{ADJ}} \times R_2)$$

where  $V_{\text{REF}} = -1.21\text{V}$ . The output voltage can be programmed within the range of -3V to -24V, typically an even greater range of -2V to -25V. The adjust pin current is about 60 nA, causing a slight error in the output voltage. However, using resistors lower than 100 k $\Omega$  makes the error due to the adjust pin current negligible. For example, neglecting the adjust pin current, and setting R2 to 100 k $\Omega$  and  $V_{\text{OUT}}$  to -5V, results in an output voltage error of only 0.16%.

### ON/OFF PIN

The LM2991 regulator can be turned off by applying a TTL or CMOS level high signal to the  $\overline{\text{ON/OFF}}$  pin. The impedance of the voltage source driving the  $\overline{\text{ON/OFF}}$  pin should be low enough to source the  $\overline{\text{ON/OFF}}$  pin input current to meet the OFF threshold voltage level, 100  $\mu\text{A}$  maximum at 2.4V.

If the  $\overline{\text{ON/OFF}}$  function is not needed, the pin should be connected to Ground. The  $\overline{\text{ON/OFF}}$  pin should not be left floating, as this is not a guaranteed operating condition.

See the Adjustable Current Sink Application, *Figure 3*.

### FORCING THE OUTPUT POSITIVE

Due to an internal clamp circuit, the LM2991 can withstand positive voltages on its output. If the voltage source pulling the output positive is DC, the current must be limited to 1.5A. A current over 1.5A fed back into the LM2991 could damage the device. The LM2991 output can also withstand fast positive voltage transients up to 26V, without any current limiting of the source. However, if the transients have a duration of over 1 ms, the output should be clamped with a Schottky diode to ground.

### THERMAL SHUTDOWN

The LM2991 has an internally set thermal shutdown point of typically 160°C, with approximately 10°C of hysteresis. This thermal shutdown temperature point is outside the guaranteed Operating Rating range, above the Absolute Maximum Rating, and is intended as a safety feature for momentary fault conditions only. Continuous operation near the thermal shutdown temperature should be avoided as it may have a negative affect on the life of the device.

## Typical Applications

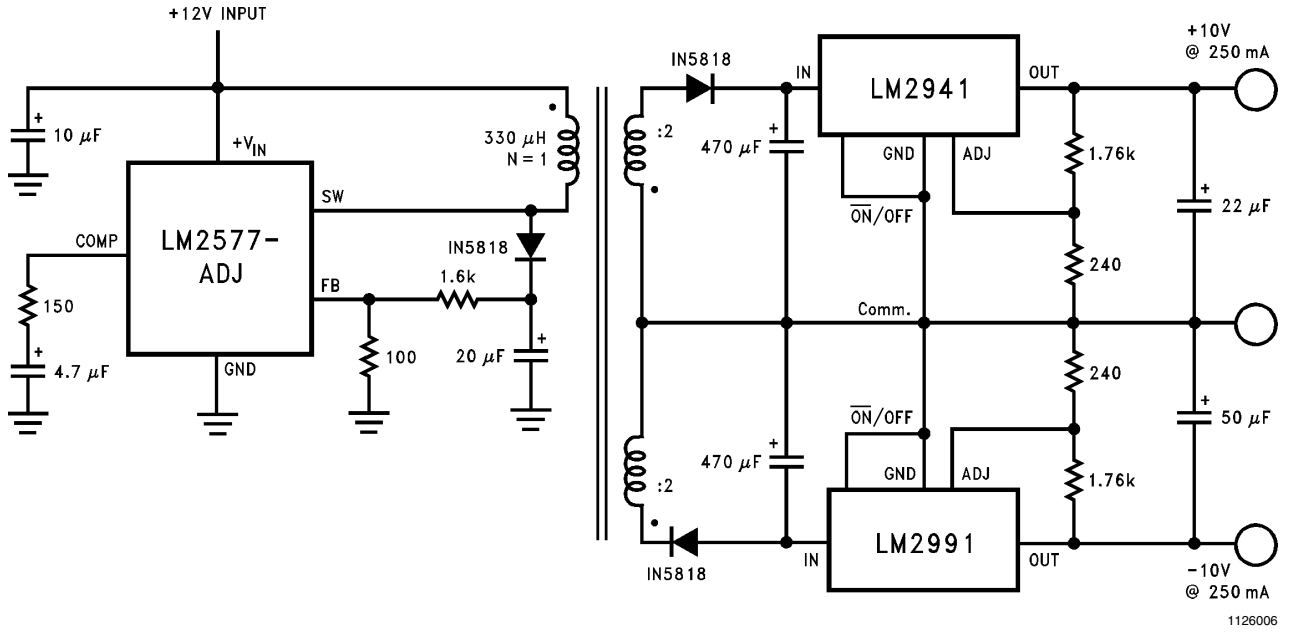

FIGURE 2. Fully Isolated Post-Switcher Regulator

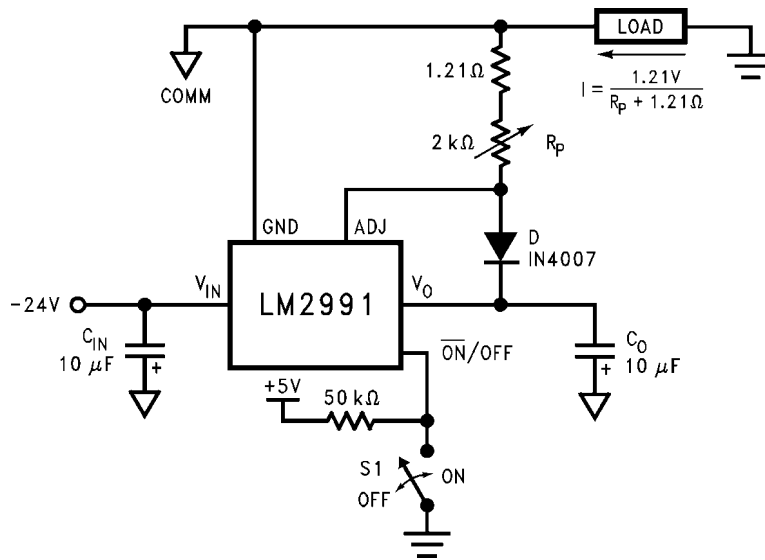
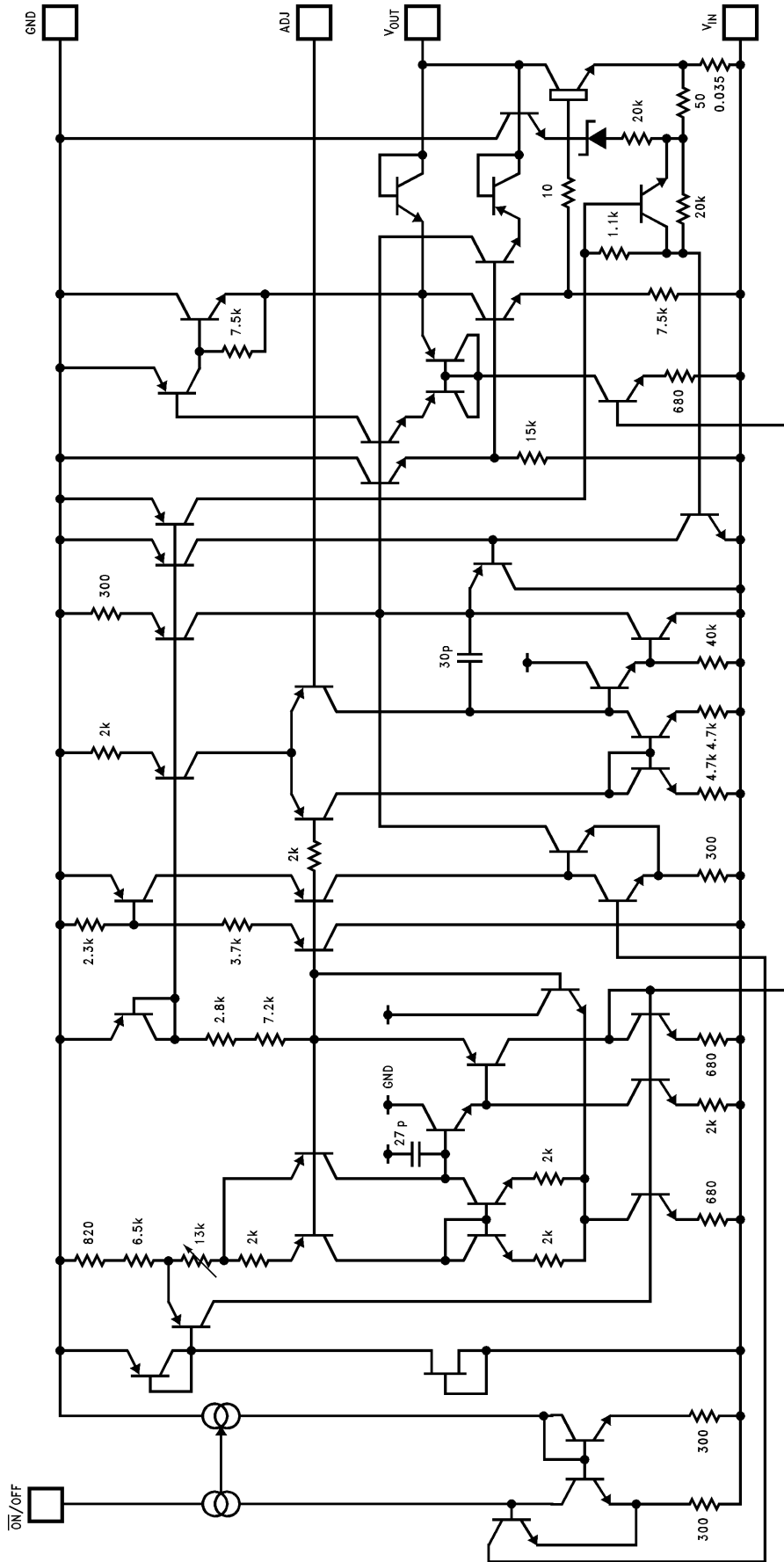

FIGURE 3. Adjustable Current Sink



# Equivalent Schematic

LM2991



1126008

**Physical Dimensions** inches (millimeters) unless otherwise noted

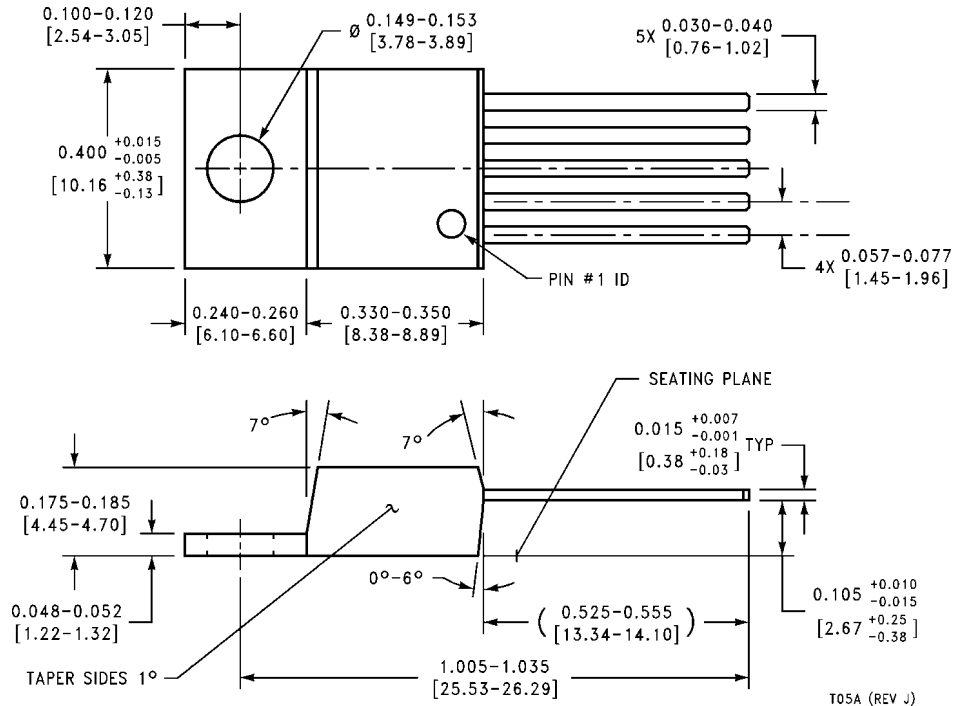

**5-Lead TO-220, Straight Leads (T)**  
**Order Number LM2991T**  
**NS Package Number T05A**

T05A (REV J)

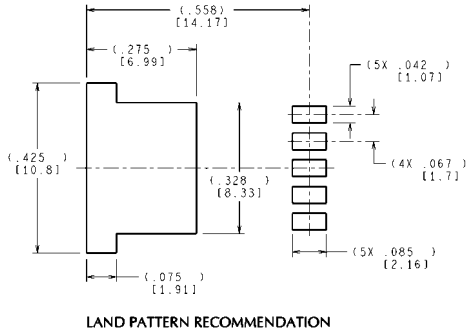
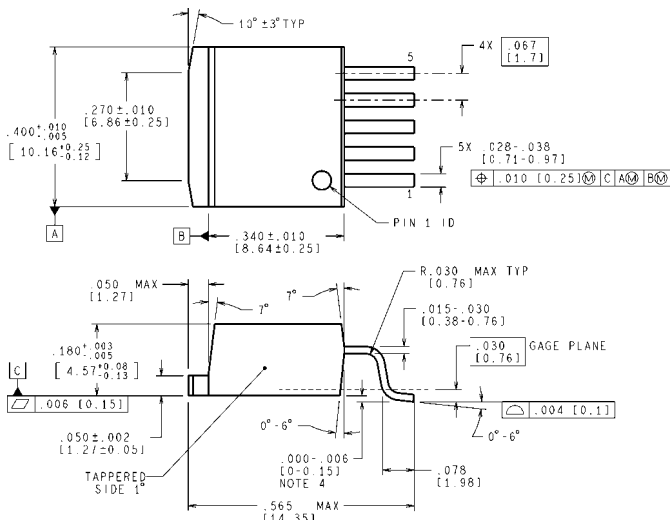

**LAND PATTERN RECOMMENDATION**

CONTROLLING DIMENSION IS INCH  
 VALUES IN [ ] ARE MILLIMETERS  
 DIMENSIONS IN ( ) FOR REFERENCE ONLY

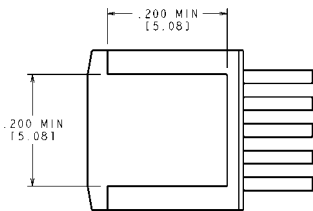

**TO-263 5-Lead Plastic Surface Mount Package**  
**Ordering Number LM2991S**  
**NS Package Number TS5B**

TS5B (Rev D)

# Notes

LM2991

## Notes

For more National Semiconductor product information and proven design tools, visit the following Web sites at:  
[www.national.com](http://www.national.com)

Products		Design Support	
Amplifiers	<a href="http://www.national.com/amplifiers">www.national.com/amplifiers</a>	WEBENCH® Tools	<a href="http://www.national.com/webench">www.national.com/webench</a>
Audio	<a href="http://www.national.com/audio">www.national.com/audio</a>	App Notes	<a href="http://www.national.com/appnotes">www.national.com/appnotes</a>
Clock and Timing	<a href="http://www.national.com/timing">www.national.com/timing</a>	Reference Designs	<a href="http://www.national.com/refdesigns">www.national.com/refdesigns</a>
Data Converters	<a href="http://www.national.com/adc">www.national.com/adc</a>	Samples	<a href="http://www.national.com/samples">www.national.com/samples</a>
Interface	<a href="http://www.national.com/interface">www.national.com/interface</a>	Eval Boards	<a href="http://www.national.com/evalboards">www.national.com/evalboards</a>
LVDS	<a href="http://www.national.com/lvds">www.national.com/lvds</a>	Packaging	<a href="http://www.national.com/packaging">www.national.com/packaging</a>
Power Management	<a href="http://www.national.com/power">www.national.com/power</a>	Green Compliance	<a href="http://www.national.com/quality/green">www.national.com/quality/green</a>
Switching Regulators	<a href="http://www.national.com/switchers">www.national.com/switchers</a>	Distributors	<a href="http://www.national.com/contacts">www.national.com/contacts</a>
LDOs	<a href="http://www.national.com/lido">www.national.com/lido</a>	Quality and Reliability	<a href="http://www.national.com/quality">www.national.com/quality</a>
LED Lighting	<a href="http://www.national.com/led">www.national.com/led</a>	Feedback/Support	<a href="http://www.national.com/feedback">www.national.com/feedback</a>
Voltage References	<a href="http://www.national.com/vref">www.national.com/vref</a>	Design Made Easy	<a href="http://www.national.com/easy">www.national.com/easy</a>
PowerWise® Solutions	<a href="http://www.national.com/powerwise">www.national.com/powerwise</a>	Applications & Markets	<a href="http://www.national.com/solutions">www.national.com/solutions</a>
Serial Digital Interface (SDI)	<a href="http://www.national.com/sdi">www.national.com/sdi</a>	Mil/Aero	<a href="http://www.national.com/milaero">www.national.com/milaero</a>
Temperature Sensors	<a href="http://www.national.com/tempensors">www.national.com/tempensors</a>	SolarMagic™	<a href="http://www.national.com/solarmagic">www.national.com/solarmagic</a>
PLL/VCO	<a href="http://www.national.com/wireless">www.national.com/wireless</a>	PowerWise® Design University	<a href="http://www.national.com/training">www.national.com/training</a>

THE CONTENTS OF THIS DOCUMENT ARE PROVIDED IN CONNECTION WITH NATIONAL SEMICONDUCTOR CORPORATION ("NATIONAL") PRODUCTS. NATIONAL MAKES NO REPRESENTATIONS OR WARRANTIES WITH RESPECT TO THE ACCURACY OR COMPLETENESS OF THE CONTENTS OF THIS PUBLICATION AND RESERVES THE RIGHT TO MAKE CHANGES TO SPECIFICATIONS AND PRODUCT DESCRIPTIONS AT ANY TIME WITHOUT NOTICE. NO LICENSE, WHETHER EXPRESS, IMPLIED, ARISING BY ESTOPPEL OR OTHERWISE, TO ANY INTELLECTUAL PROPERTY RIGHTS IS GRANTED BY THIS DOCUMENT.

TESTING AND OTHER QUALITY CONTROLS ARE USED TO THE EXTENT NATIONAL DEEMS NECESSARY TO SUPPORT NATIONAL'S PRODUCT WARRANTY. EXCEPT WHERE MANDATED BY GOVERNMENT REQUIREMENTS, TESTING OF ALL PARAMETERS OF EACH PRODUCT IS NOT NECESSARILY PERFORMED. NATIONAL ASSUMES NO LIABILITY FOR APPLICATIONS ASSISTANCE OR BUYER PRODUCT DESIGN. BUYERS ARE RESPONSIBLE FOR THEIR PRODUCTS AND APPLICATIONS USING NATIONAL COMPONENTS. PRIOR TO USING OR DISTRIBUTING ANY PRODUCTS THAT INCLUDE NATIONAL COMPONENTS, BUYERS SHOULD PROVIDE ADEQUATE DESIGN, TESTING AND OPERATING SAFEGUARDS.

EXCEPT AS PROVIDED IN NATIONAL'S TERMS AND CONDITIONS OF SALE FOR SUCH PRODUCTS, NATIONAL ASSUMES NO LIABILITY WHATSOEVER, AND NATIONAL DISCLAIMS ANY EXPRESS OR IMPLIED WARRANTY RELATING TO THE SALE AND/OR USE OF NATIONAL PRODUCTS INCLUDING LIABILITY OR WARRANTIES RELATING TO FITNESS FOR A PARTICULAR PURPOSE, MERCHANTABILITY, OR INFRINGEMENT OF ANY PATENT, COPYRIGHT OR OTHER INTELLECTUAL PROPERTY RIGHT.

#### LIFE SUPPORT POLICY

**NATIONAL'S PRODUCTS ARE NOT AUTHORIZED FOR USE AS CRITICAL COMPONENTS IN LIFE SUPPORT DEVICES OR SYSTEMS WITHOUT THE EXPRESS PRIOR WRITTEN APPROVAL OF THE CHIEF EXECUTIVE OFFICER AND GENERAL COUNSEL OF NATIONAL SEMICONDUCTOR CORPORATION.** As used herein:

Life support devices or systems are devices which (a) are intended for surgical implant into the body, or (b) support or sustain life and whose failure to perform when properly used in accordance with instructions for use provided in the labeling can be reasonably expected to result in a significant injury to the user. A critical component is any component in a life support device or system whose failure to perform can be reasonably expected to cause the failure of the life support device or system or to affect its safety or effectiveness.

National Semiconductor and the National Semiconductor logo are registered trademarks of National Semiconductor Corporation. All other brand or product names may be trademarks or registered trademarks of their respective holders.

Copyright© 2011 National Semiconductor Corporation

For the most current product information visit us at [www.national.com](http://www.national.com)



**National Semiconductor  
Americas Technical  
Support Center**  
Email: [support@nsc.com](mailto:support@nsc.com)  
Tel: 1-800-272-9959

**National Semiconductor Europe  
Technical Support Center**  
Email: [europe.support@nsc.com](mailto:europe.support@nsc.com)

**National Semiconductor Asia  
Pacific Technical Support Center**  
Email: [ap.support@nsc.com](mailto:ap.support@nsc.com)

**National Semiconductor Japan  
Technical Support Center**  
Email: [jpn.feedback@nsc.com](mailto:jpn.feedback@nsc.com)