

NUMBER <b>GS-12-0903</b>	TYPE <b>PRODUCT SPECIFICATION</b>		
TITLE <b>TRX10GVP2010C1 (SFP+ SR Module)</b>		PAGE <b>1 of 16</b>	REVISION <b>A</b>
		AUTHORIZED BY <b>J. Blank</b>	DATE <b>06-02-11</b>
CLASSIFICATION <b>UNRESTRICTED</b>			

## 10 GBd SFP+ 850 nm Limiting Transceiver TRX10GVP2010C1



### Product Features:

- Hot pluggable SFP+ optical transceiver
- Programmable input and output equalizers
- Data rate transparent from 9.95 to 11.3 Gbps
- Low power consumption, 0.55 W typ.
- Excellent EMI performance
- Transmission distance up to 300 m OM3 MMF
- 0 °C to +70 °C case operating temperature
- 850 nm VCSEL laser
- Duplex LC connector
- Laser Class 1
- RoHS 6/6 compliant

### Applications:

- 10G Ethernet 10GBASE-SR/SW
- 10G Fibre Channel 1200-MX-SN-I

FCI's SFP+ optical transceiver TRX10GVP2010C1 is compliant with the current SFP+ MSA specifications (SFF-8431 and SFF-8432) and with 10GBASE-SR/SW per IEEE 802.3 as well as 1200-MX-SN-I per 10G Fibre Channel. It is RoHS 6/6 compliant per Directive 2002/95/EC and laser class 1 safety compliant per IEC/CDRH. The sub-Watt power consumption and the excellent EMI performance allow system design with high port density. Adjustable input and output equalizers allow to overcome host board high frequency signal loss and to optimize module performance in interaction with host board equalizers.

### Supported Standards

Application	Standard	Data Rate
10G Ethernet LAN/WAN	IEEE 802.3 10GBASE-SR/SW	10.312 / 9.953 Gbps
10G Fibre Channel	1200-MX-SN-I	10.518 Gbps

**PDS: Rev :A**

**STATUS:Released**

**Printed: Jun 15, 2011**

Copyright FCI.

Form E-3701 – Revision C

GS-01-029

NUMBER <b>GS-12-0903</b>	TYPE <b>PRODUCT SPECIFICATION</b>		
TITLE <b>TRX10GVP2010C1 (SFP+ SR Module)</b>		PAGE <b>2 of 16</b>	REVISION <b>A</b>
		AUTHORIZED BY <b>J. Blank</b>	DATE <b>06-02-11</b>
		CLASSIFICATION <b>UNRESTRICTED</b>	

## Table of Contents

Table of Contents.....	2
Functional Description .....	3
Electrical Characteristics .....	4
Absolute Maximum Ratings .....	4
Recommended Operating Conditions .....	4
Low Speed Characteristics .....	4
SFI Module Transmitter Input Characteristics .....	5
SFI Module Receiver Output Characteristics .....	5
Optical Characteristics .....	6
General Parameters .....	6
Optical Transmitter.....	6
Optical Receiver.....	6
Application Information .....	7
Connector Pinout .....	7
Electrical Pin Definition .....	7
Application Schematics.....	8
Interfacing the Transceiver .....	9
Digital Optical Monitoring .....	9
Tx Input & Rx Output Equalizer Adjustment .....	10
Programmability Feature Code.....	11
Passcode Entry and Modification .....	11
Module Outline.....	12
Module Safety & Compliance .....	13
ESD & Electromagnetic Compatibility.....	13
Eye Safety.....	14
Ordering Information .....	15
Revision Record .....	16

**PDS: Rev :A**

**STATUS:Released**

**Printed: Jun 15, 2011**

Copyright FCI.

Form E-3701 – Revision C

GS-01-029

NUMBER <b>GS-12-0903</b>	TYPE <b>PRODUCT SPECIFICATION</b>		
TITLE <b>TRX10GVP2010C1 (SFP+ SR Module)</b>		PAGE <b>3 of 16</b>	REVISION <b>A</b>
		AUTHORIZED BY <b>J. Blank</b>	DATE <b>06-02-11</b>
CLASSIFICATION <b>UNRESTRICTED</b>			

## Functional Description

The transmit path is based on an AC coupled 100 ohm differentially terminated driver coupled to an 850 nm VCSEL. Laser output may be disabled by pulling the transmitter disable (TX\_DIS) line high which is its default state when leaving the input floating due to an internal pull-up resistor. A fault condition is raised upon detection of an abnormal laser state.

The receive path consists of a receiver optical sub-assembly (ROSA) for optical to electrical conversion, followed by a limiting amplifier boosting the electrical signal. A loss of signal (LOS) status line provides information to facilitate easy link detection.

Complete digital optical monitoring is implemented in compliance to SFF-8472 and made accessible via the 2-wire interface providing real time information about all important module parameters and status information.

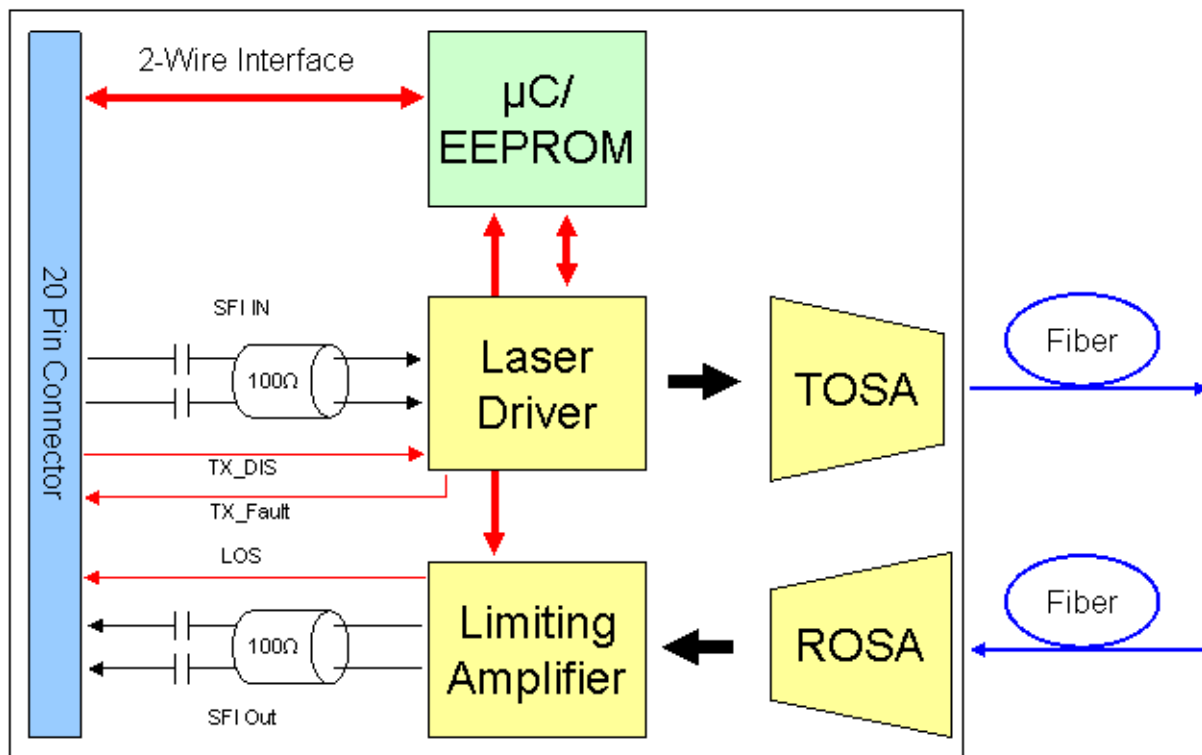

NUMBER <b>GS-12-0903</b>	TYPE <b>PRODUCT SPECIFICATION</b>				
TITLE <b>TRX10GVP2010C1 (SFP+ SR Module)</b>		PAGE <b>4 of 16</b>	REVISION <b>A</b>		
		AUTHORIZED BY <b>J. Blank</b>	DATE <b>06-02-11</b>		
		CLASSIFICATION <b>UNRESTRICTED</b>			

## Electrical Characteristics

### Absolute Maximum Ratings

Rating	Conditions	Symbol	Min	Max	Units
Storage Ambient Temperature		$\vartheta_{stg}$	-40	+85	°C
Powered Case Temperature		$\vartheta_c$	0	+75	°C
Operating Relative Humidity	Non condensing	RH	0	95	%
Supply Voltage Range		$V_{CCT/R}$	-0.5	4.0	V

Any stress beyond the maximum ratings may result in permanent damage to the device. Specifications are guaranteed only under recommended operating conditions.

### Recommended Operating Conditions

Parameter	Conditions	Symbol	Min	Typ	Max	Units
Operating Case Temperature		$\vartheta_{Case}$	0		+70	°C
Power Supply Voltage		$V_{CCT/R}$	3.135	3.30	3.465	V
DC Common Mode Voltage	SFI Signals	$V_{CM}$	-0.5		4.0	V

### Low Speed Characteristics

Parameter	Conditions	Symbol	Min	Typ	Max	Units
Supply Current Transmitter	@ $V_{CCT}$	$I_{VCCTX}$			100	mA
Supply Current Receiver	@ $V_{CCR}$	$I_{VCCR X}$			120	mA
Power Consumption				0.55	0.75	W
TX_Fault, RX_LOS	Host Vcc Range 2 V – 3.47 V, $I_{OL\_max} = 4$ mA	$V_{OL}$	0		0.4	V
		$V_{OH}$	Host_Vcc – 0.5		Host_Vcc + 0.3	
TX_Dis, RS0, RS1	Low Voltage TTL	$V_{IL}$	-0.3		0.8	
		$V_{IH}$	2.0		$V_{CCT} + 0.5$	
SCL, SDA	Host Vcc Range 3.13 V – 3.47 V, $I_{OL\_max} = 4$ mA	$V_{IL}$	-0.3		$V_{CCT}^* + 0.3$	
		$V_{IH}$	$V_{CCT}^* + 0.7$		$V_{CCT} + 0.5$	
		$V_{OL}$	0.0		0.4	
		$V_{OH}$	Host_Vcc – 0.5		Host_Vcc + 0.3	

NUMBER <b>GS-12-0903</b>	TYPE <b>PRODUCT SPECIFICATION</b>		
<b>TRX10GVP2010C1 (SFP+ SR Module)</b>		PAGE <b>5 of 16</b>	REVISION <b>A</b>
		AUTHORIZED BY <b>J. Blank</b>	DATE <b>06-02-11</b>
		CLASSIFICATION <b>UNRESTRICTED</b>	

### SFI Module Transmitter Input Characteristics

Parameter	Conditions	Symbol	Min	Typ	Max	Units
Nominal Data Rate				10.3125		Gbd
Reference Differential Input Impedance		$Z_d$		100		$\Omega$
Input AC Common Mode Input Voltage			0		25	mV (RMS)
Differential Input Voltage Swing	$2 \times  V(TD+) - V(TD-) $	$V_{ID}$	150		900	mV
Differential Input S-parameter	0.01 – 4.1 GHz	SDD11			<sup>1)</sup>	dB
	4.1 – 11.1 GHz				<sup>2)</sup>	dB
Differential to Common Mode Conversion <sup>3)</sup>	0.01 – 11.1 GHz	SCD11			-10	dB
Total Jitter		TJ			0.28	UI(p-p)
Data Dependent Jitter		DDJ			0.1	UI(p-p)
Uncorrelated Jitter		UJ			0.023	RMS

- 1) Reflection coefficient given by equation  $SDD11(dB) < -12 + 2 \times \text{SQRT}(f)$ , with f in GHz.
- 2) Reflection coefficient given by equation  $SDD11(dB) < -6.3 + 13 \times \text{Log}_{10}(f/5.5)$ , with f in GHz.
- 3) Common mode reference impedance is 25 $\Omega$ .

### SFI Module Receiver Output Characteristics

Parameter	Conditions	Symbol	Min	Typ	Max	Units
Nominal Data Rate				10.3125		Gbd
Reference Differential Output Impedance		$Z_d$		100		$\Omega$
Termination Mismatch		$\Delta Z_d$			5	%
Output AC Common Mode Voltage					7.5	mV (RMS)
Differential Output Amplitude	$R_{Load} = 100 \text{ ohm},$ $2 \times  V(RD+) - V(RD-) $	$V_{OSPP}$	350	520	800	mV
Output Rise and Fall Time	20 % to 80 %	$t_R, t_F$	28			ps
Differential Output S-parameter	0.01 – 4.1 GHz	SDD22			<sup>1)</sup>	dB
	4.1 – 11.1 GHz				<sup>2)</sup>	dB
Common Mode Output Return Loss <sup>4)</sup>	0.01 – 2.5 GHz	SCC22			<sup>3)</sup>	dB
	2.5 – 11.1 GHz				-3	dB
Deterministic Jitter		DJ			0.42	UI(p-p)
Total Jitter	See SFP+ MSA	TJ			0.7	UI(p-p)

- 1) Reflection coefficient given by equation  $SDD22(dB) < -12 + 2 \times \text{SQRT}(f)$ , with f in GHz.
- 2) Reflection coefficient given by equation  $SDD22(dB) < -6.3 + 13 \times \text{Log}_{10}(f/5.5)$ , with f in GHz.
- 3) Reflection coefficient given by equation  $SCC22(dB) = -7 + 1.6 \times f$ , with f in GHz
- 4) Common mode reference impedance is 25 $\Omega$ .

NUMBER <b>GS-12-0903</b>	TYPE <b>PRODUCT SPECIFICATION</b>		
TITLE <b>TRX10GVP2010C1 (SFP+ SR Module)</b>		PAGE <b>6 of 16</b>	REVISION <b>A</b>
		AUTHORIZED BY <b>J. Blank</b>	DATE <b>06-02-11</b>
CLASSIFICATION <b>UNRESTRICTED</b>			

## Optical Characteristics

### General Parameters

Parameter	Conditions	Min Modal Bandwidth (MHz*km)	Symbol	Min	Typical 1GBd	Typical 10GBd	Units
Operating Range	62.5 $\mu$ m MMF	160	$I_{OP}$	2	220	26	m
	50 $\mu$ m MMF	400		2	500	66	
	62.5 $\mu$ m MMF	200		0.5	275	33	
	50 $\mu$ m MMF	500		0.5	550	82	
	50 $\mu$ m MMF	2000		0.5	X	300	

### Optical Transmitter

Parameter	Conditions	Symbol	Min	Typ	Max	Units
Center Wavelength		$\lambda_{TRP}$	840	850	860	nm
RMS Spectral Width		$\Delta\lambda$			0.45	
Average Launch Power		$P_{avg}$	-7.3		-1	dBm
Optical Modulation Amplitude		$P_{OMA}$	-2.9			dBm
Extinction Ratio		ER	3.5			dB
Relative Intensity Noise		RIN			-128	dB/Hz

### Optical Receiver

Parameter	Conditions	Symbol	Min	Typ	Max	Units
Center Wavelength		$\lambda_C$	840	850	860	nm
Maximum Average Input Power		$P_{MAX}$	-1			dBm
Receiver Sensitivity	PRBS $2^{31}-1$ , BER < $1*10^{-12}$ @10.3125GBd	$P_{IN(OMA)}$		-15	-12	dBm
Stressed Receiver Sensitivity	PRBS $2^{31}-1$ , BER < $1*10^{-12}$ @ 10.3125GBd	$P_{IN(OMA)}$		-11	-8	dBm
Loss of Signal	Assert	$P_{avg\_as}$	-30	-19		dBm
	De-Assert	$P_{OMA\_deas}$		-17	-13	
Loss of Signal Hysteresis		Hyst	1			dB

Note: The specified characteristics are met within the recommended range of operating. Unless otherwise noted, typical data are quoted at nominal voltages and +25°C ambient temperature.

NUMBER <b>GS-12-0903</b>	TYPE <b>PRODUCT SPECIFICATION</b>		
TITLE <b>TRX10GVP2010C1 (SFP+ SR Module)</b>		PAGE <b>7 of 16</b>	REVISION <b>A</b>
		AUTHORIZED BY <b>J. Blank</b>	DATE <b>06-02-11</b>
CLASSIFICATION <b>UNRESTRICTED</b>			

## Application Information

### Connector Pinout

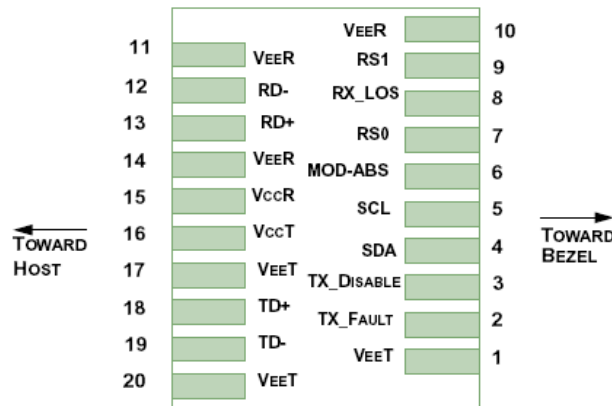

### Electrical Pin Definition

PIN	Logic	Symbol	Name / Description	Note
1		VeeT	Module Transmitter Ground	1
2	LVTTL-O	TX_Fault	Module Transmitter Fault	
3	LVTTL-I	TX_Dis	Transmitter Disable; Turns off transmitter laser output	
4	LVTTL-I/O	SDA	2-Wire Serial Interface Data Line	2
5	LVTTL-I	SCL	2-Wire Serial Interface Clock	2
6		MOD_ABS	(=MOD_DEF0) Module Absent, shorted to module ground	
7	LVTTL-I	RS0	Receiver Rate Select	
8	LVTTL-O	RX_LOS	Receiver Loss of Signal Indication Active LOW	
9	LVTTL-I	RS1	Transmitter Rate Select	
10		VeeR	Module Receiver Ground	1
11		VeeR	Module Receiver Ground	1
12	CML-O	RD-	Receiver Inverted Data Output	
13	CML-O	RD+	Receiver Data Output	
14		VeeR	Module Receiver Ground	1
15		VccR	Module Receiver 3.3 V Supply	
16		VccT	Module Transmitter 3.3 V Supply	
17		VeeT	Module Transmitter Ground	1
18	CML-I	TD+	Transmitter Non-Inverted Data Input	
19	CML-I	TD-	Transmitter Inverted Data Input	
20		VeeT	Module Transmitter Ground	1

1. Module ground pins Vee are isolated from the module case.
2. Shall be pulled up with 1k-10k ohms to a voltage between 3.13 V and 3.47 V on the host board.

PDS: Rev :A

STATUS:Released

Printed: Jun 15, 2011

Copyright FCI.

Form E-3701 – Revision C

GS-01-029

NUMBER <b>GS-12-0903</b>	TYPE <b>PRODUCT SPECIFICATION</b>		
TITLE <b>TRX10GVP2010C1 (SFP+ SR Module)</b>		PAGE <b>8 of 16</b>	REVISION <b>A</b>
		AUTHORIZED BY <b>J. Blank</b>	DATE <b>06-02-11</b>
		CLASSIFICATION <b>UNRESTRICTED</b>	

## Application Schematics

Recommended electrical connections to transceiver are shown below. Pull-ups: 1k – 10k ohms.

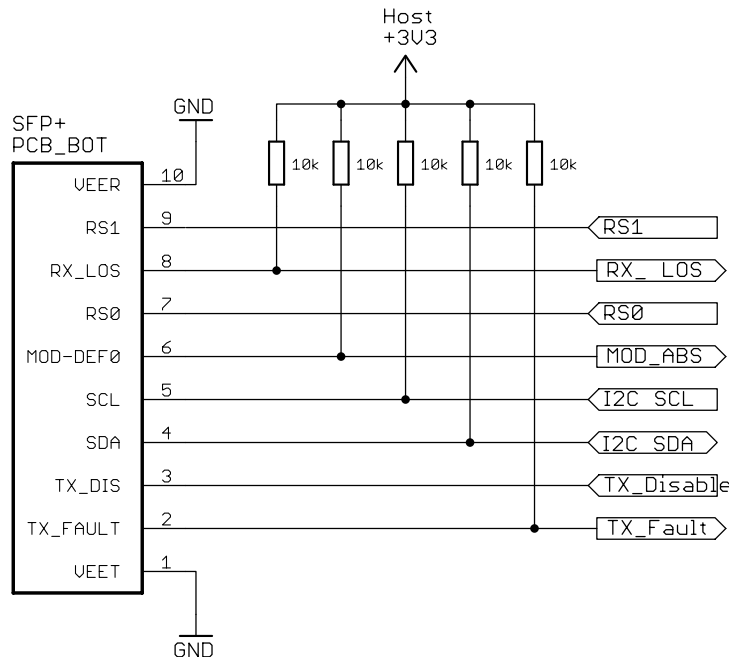
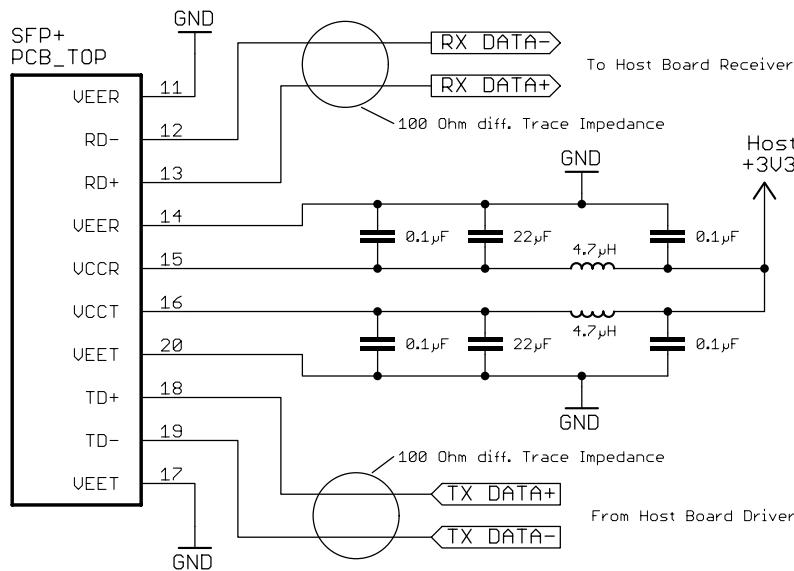

**PDS: Rev :A**

**STATUS:Released**

**Printed: Jun 15, 2011**

Copyright FCI.

Form E-3701 – Revision C

GS-01-029



NUMBER <b>GS-12-0903</b>	TYPE <b>PRODUCT SPECIFICATION</b>		
TITLE <b>TRX10GVP2010C1 (SFP+ SR Module)</b>		PAGE <b>9 of 16</b>	REVISION <b>A</b>
		AUTHORIZED BY <b>J. Blank</b>	DATE <b>06-02-11</b>
CLASSIFICATION <b>UNRESTRICTED</b>			

### Interfacing the Transceiver

Communication is done by a serial 2-wire interface compatible to the I2C bus protocol. Refer to SFF-8472 for a more detailed explanation of the registers:

Base Address A0h	
Register	Content
0 - 95	Serial Transceiver ID as defined in SFP MSA
96 - 127	FCI Specific
128 - 255	Reserved

Base Address A2h	
Register	Content
0 - 55	Alarm & Warnings Thresholds & Limits
56 - 95	External calibration constants (not used)
96 - 119	Values from real time diagnostic monitoring
120(LSB) – 123(MSB)	Passcode change field
124(LSB) – 127(MSB)	Passcode entry field
128 – 247	Customer specific, writable area
248	Input & output equalizer settings
249 - 253	Reserved
254	Feature code
255	Reserved

### Digital Optical Monitoring

The transceiver offers the ability to monitor important module parameter during operation. All five parameters listed below are continuously monitored for getting information about the current module status. All data is calibrated internally; there is no need for external post processing.

#### Temperature

Internally measured temperature data is represented as two's complement of a signed 16-bit value in increments of 1/256 °C over a range of -40 to +100 °C. Accuracy is better than +/-3 °C.

#### Supply Voltage (VCC)

Internally measured supply voltage. Represented as a 16-bit unsigned integer with the voltage defined as the full 16 bit value (0 – 65535) with LSB equal to 100 µVolt, which yields to a total range of 0 to +6.55 Volts. Accuracy is better than +/-3 %.

#### Laser Bias Current

The VCSEL bias current is represented as a 16 bit unsigned integer with the current defined as the full 16-bit value (0 – 65535) with LSB equal to 2 µA. Accuracy is better than +/-10 %.

#### Optical Transmitter Power

TX output power measurement is based on internal monitor diode feedback. Represented as a 16-bit unsigned integer with the power defined as the full 16 bit value (0 – 65535) with LSB equal to 0.1 µW. Accuracy is better than +/-3 dB over a range of  $P_{avg,min}$  to  $P_{avg,max}$ .

NUMBER <b>GS-12-0903</b>	TYPE <b>PRODUCT SPECIFICATION</b>		
<b>TRX10GVP2010C1 (SFP+ SR Module)</b>		PAGE <b>10 of 16</b>	REVISION <b>A</b>
		AUTHORIZED BY <b>J. Blank</b>	DATE <b>06-02-11</b>
		CLASSIFICATION <b>UNRESTRICTED</b>	

### Receiver Optical Power

RX input power measurement is based on photodiode average current. Represented as a 16-bit unsigned integer with the power defined as the full 16 bit value (0 – 65535) with LSB equal to 0.1  $\mu$ W. Accuracy is better than +/-3 dB over a range of -12 dBm to -1 dBm.

Note: The specified characteristics are met within the recommended range of operating conditions regarding temperature and voltage.

### Tx Input & Rx Output Equalizer Adjustment

The transceiver is equipped with equalizers at the transmitter input and at the receiver output (at the electrical module interface) to compensate for high frequency signal loss on the host board printed circuit board (Host-PCB) into which the transceiver is plugged and to allow performance optimization in interaction with host board equalizers (if there are any).

There are different module equalizer settings available to adjust the strength of the equalization which may be selected according to the line length of Host-PCB signal tracks.

MSB	Content of Register 248 in Table A2h						LSB
reserved	Tx2	Tx1	Tx0	reserved	Rx2	Rx1	Rx0

Register 248 is always readable, but only writable if a valid passcode has been written to registers 124 – 127 of table A2h before (see paragraph Passcode Entry and Modification below). Reserved bits of register 248 should be written to 0. After power up, the module always comes up with its factory programmed default equalizer settings.

Transmitter Input Signal Equalizer Settings:

Tx2	Tx1	Tx0	Description
0	X	X	Input equalizer off
1	0	0	Low equalization
1	0	1	Reserved
1	1	0	Default equalization (factory setting)
1	1	1	Reserved

X: don't care

Receiver Output Signal Equalizer (Peaking) Settings:

Rx2	Rx1	Rx0	Description
0	0	0	Output peaking off (default)
0	0	1	Lowest peaking
...	...	...	Increased peaking between 001 up to 111
1	1	1	Strongest peaking

NUMBER <b>GS-12-0903</b>	TYPE <b>PRODUCT SPECIFICATION</b>		
<b>TRX10GVP2010C1 (SFP+ SR Module)</b>		PAGE <b>11 of 16</b>	REVISION <b>A</b>
		AUTHORIZED BY <b>J. Blank</b>	DATE <b>06-02-11</b>
		CLASSIFICATION <b>UNRESTRICTED</b>	

### Programmability Feature Code

Register 254 of table A2h indicates the programmability features available and an implementation code to distinguish different implementations. This is a read only register.

MSB	Content of Register 248 in Table A2h						LSB
Tx Equal.	Rx Equal.	reserved	reserved	reserved	I-Code2	I-Code1	I-Code0

Tx Equal.: is set to 1 if the transceiver supports programming of the Tx equalizer.

Rx Equal.: is set to 1 if the transceiver supports programming of the Rx equalizer.

I-Code2...0: implementation code. Yields 001b at read out.

### Passcode Entry and Modification

Write-access to the transceiver programmability features and to the customer specific writable area (128 – 247 of table A2h) is granted via a valid passcode which has to be written to the passcode entry field (registers 124-127 of table A2h). Please contact FCI for the factory preset initial passcode. The passcode may be changed to a proprietary one by entering the new one into the passcode change field (registers 120-123 of table A2h) after a valid passcode has been written to the passcode entry field.

NUMBER <b>GS-12-0903</b>	TYPE <b>PRODUCT SPECIFICATION</b>		
TITLE <b>TRX10GVP2010C1 (SFP+ SR Module)</b>		PAGE <b>12 of 16</b>	REVISION <b>A</b>
		AUTHORIZED BY <b>J. Blank</b>	DATE <b>06-02-11</b>
CLASSIFICATION <b>UNRESTRICTED</b>			

## Module Outline

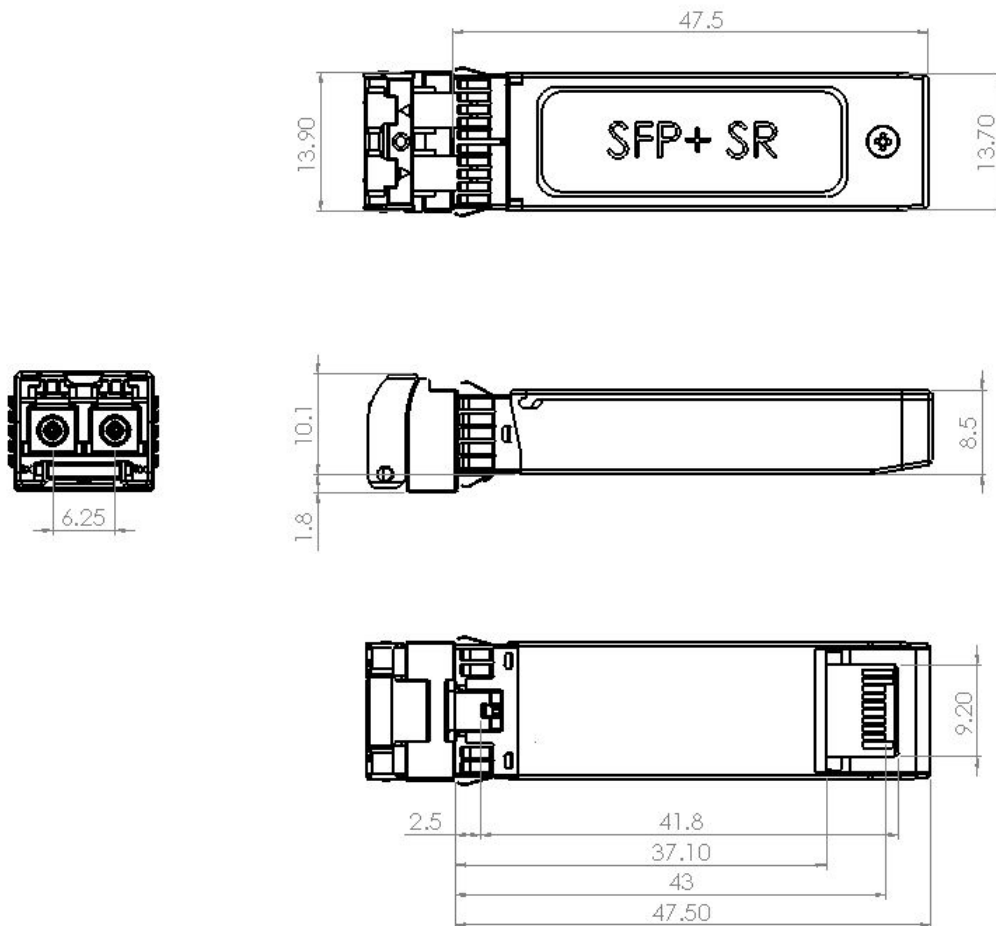

All dimensions shown are in millimeters.

NUMBER <b>GS-12-0903</b>	TYPE <b>PRODUCT SPECIFICATION</b>		
TITLE <b>TRX10GVP2010C1 (SFP+ SR Module)</b>		PAGE <b>13 of 16</b>	REVISION <b>A</b>
		AUTHORIZED BY <b>J. Blank</b>	DATE <b>06-02-11</b>
		CLASSIFICATION <b>UNRESTRICTED</b>	

## Module Safety & Compliance

FCI's SFP+ SR module is designed to meet international standards and requirements. The module is RoHS compliant according to the European Parliament requirements on the restriction of the use of hazardous substances in electrical and electronic equipment (RoHS). The module optical output power meets Class 1 requirements for laser safety.

Requirements	Standard
Module Safety	IEC 60950-1:2001 EN 60950-1:2001
RoHS Compliance	RoHS 6/6 Directive 2002/95/EC Amendment 4054 (2005/747/EC)
Laser Safety (Class 1)	CDRH 21 CFR 1040.10 and 1040.11 (according FDA) IEC 60825-1 Rev2 2007 (according IEC)

## ESD & Electromagnetic Compatibility

Requirements	Standard	Value
EMI (Emission)	FCC Part 15 B EN 55022 Class B CISPR 22 30 MHz ... 40 GHz	At least 6 dB margin to Class B limit
EMI (Immunity)	IEC 61000-4-3, 10 MHz ... 1 GHz	No bit errors at sensitivity limit
ESD (Electrical connector)	EIA/JESD22-A114-B MIL-STD 883C Method 3015.7	≥ 2 kV ≥ 1 kV (SFI signals)
ESD (Module case)	Air Discharge EN61000-4-2, Criterion B	≥ 15 kV
ESD (Module case)	Contact Discharge EN61000-4-2, Criterion B	≥ 8 kV

NUMBER <b>GS-12-0903</b>	TYPE <b>PRODUCT SPECIFICATION</b>		
<b>TITLE</b>  <b>TRX10GVP2010C1 (SFP+ SR Module)</b>		PAGE <b>14 of 16</b>	REVISION <b>A</b>
		AUTHORIZED BY <b>J. Blank</b>	DATE <b>06-02-11</b>
		CLASSIFICATION <b>UNRESTRICTED</b>	

## Eye Safety

This laser based multimode transceiver is a Class 1 product. It complies with IEC 60825-1 Edition 2 and FDA performance standards for laser products (21 CFR 1040.10 and 1040.11) except for deviations pursuant to Laser Notice 50, dated July 26, 2001.

### CLASS 1 LASER PRODUCT

To meet laser safety requirements the transceiver shall be operated within the Absolute Maximum Ratings.

*Note: All adjustments have been made at the factory prior to shipment of the devices. No maintenance or alteration to the device is required. Tampering with or modifying the performance of the device will result in voided product warranty. Failure to adhere to the above restrictions could result in a modification that is considered an act of "manufacturing", and will require, under law, recertification of the modified product with the U.S. Food and Drug Administration (ref. 21 CFR 1040.10 (i)).*

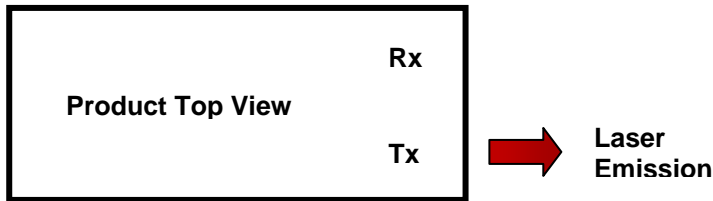

Wavelength	>840 nm
Accessible Emission Limit (as defined by IEC: 7 mm aperture at 70 mm distance)	<743 $\mu$ W

NUMBER <b>GS-12-0903</b>	TYPE <b>PRODUCT SPECIFICATION</b>		
TITLE <b>TRX10GVP2010C1 (SFP+ SR Module)</b>		PAGE <b>15 of 16</b>	REVISION <b>A</b>
		AUTHORIZED BY <b>J. Blank</b>	DATE <b>06-02-11</b>
		CLASSIFICATION <b>UNRESTRICTED</b>	

## Ordering Information

Application	Standard	Part Number
<b>10G Ethernet LAN/WAN</b>	IEEE 802.3 10GBASE-SR/SW	TRX10GVP2010C1
<b>10G Fibre Channel</b>	10GFC 1200-MX-SN-I	TRX10GVP2010C1

**NOTE:**

Copyright © 2011 FCI Deutschland GmbH. FCI Deutschland GmbH reserves the right to make changes to this document at any time without notice. Information in this document is believed to be reliable. However, no responsibility is assumed for possible inaccuracy or omission.

NUMBER <b>GS-12-0903</b>	TYPE <b>PRODUCT SPECIFICATION</b>		
TITLE <b>TRX10GVP2010C1 (SFP+ SR Module)</b>		PAGE <b>16 of 16</b>	REVISION <b>A</b>
		AUTHORIZED BY <b>J. Blank</b>	DATE <b>06-02-11</b>
CLASSIFICATION <b>UNRESTRICTED</b>			

## REVISION RECORD

<b>Rev</b>	<b>Page</b>	<b>Description</b>	<b>EC#</b>	<b>Date</b>
A	All	Rev C01 Released New Product Specification	N/A	6-03-11