

NOTE


All numerical values are in metric units [with U.S. customary units in brackets]. Dimensions are in millimeters [and inches]. Unless otherwise specified, dimensions have a tolerance of ± 0.13 [$\pm .005$] and angles have a tolerance of $\pm 2^\circ$. Figures and illustrations are for identification only and are not drawn to scale.

1. INTRODUCTION

This specification covers the requirements for application of ELCON Drawer Series Connectors: True Hot Plug, Blind Mating Mixed Signal and Power Connectors. These connectors are designed for use in pluggable wire-to-board applications of power supplies. The connectors are available in a variety of custom configurations. The pin side connector accepts pin contacts, and the socket side connector accepts socket contacts. The contact cavities on both sides of the connector are marked for circuit identification.

The high power connectors are available with or without pre-installed guide pins; mid and low power connectors are designed with molded-in guide posts to ensure positive mating of connectors. The molded-in pin protectors prevent damage to the contacts. These features (including the guide pin holes and guide post cavities) have chamfered edges for ease of mating. The connectors are designed for float-mount and fixed-mount applications to allow blind mating with misalignment. All connectors are also designed with standoffs to allow easy printed circuit (pc) board cleaning after soldering.

The contacts accept wire sizes 24 through 1/0 AWG. Contact sizes 20, 16, and 12 are available in crimp type, and solder type terminations. In addition, contact size 12 is available in hot plug, specifically designed for current interruption capability. Contact size 0 and 4 is available in crimp type termination, internal thread and external thread for ring lug mounting and bus bar mounting. Pin contacts (except size 0 and 4) are available in three lengths: standard, pre mate, and post mate for flexibility in contact sequencing. The contacts contain an active element, or crown band, which ensures maximum surface contact area, allows even insertion and withdrawal forces, and provides shock and vibration resistance. The contacts are available in loose piece only. Only crimp type and threaded contacts are removable.

When corresponding with Tyco Electronics Personnel, use the terminology provided in this specification to facilitate your inquiries for information. Basic terms and features of these connectors are provided in Figure 1.

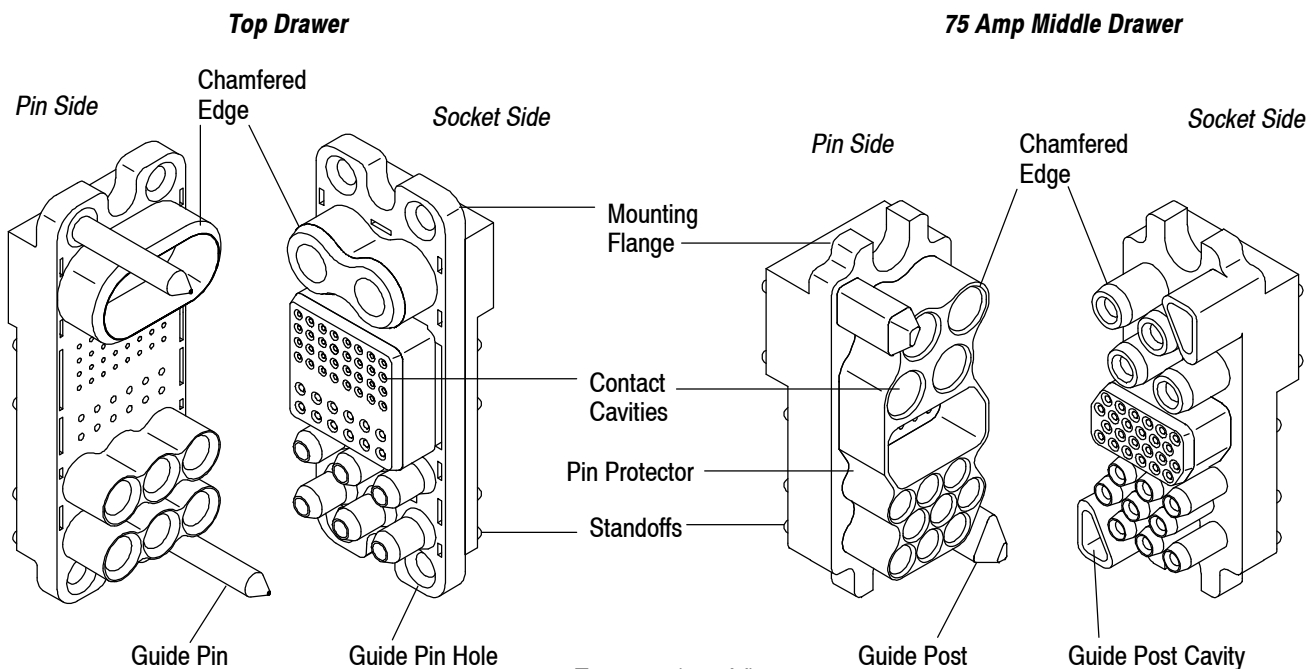
ELCON


Figure 1 (cont'd)

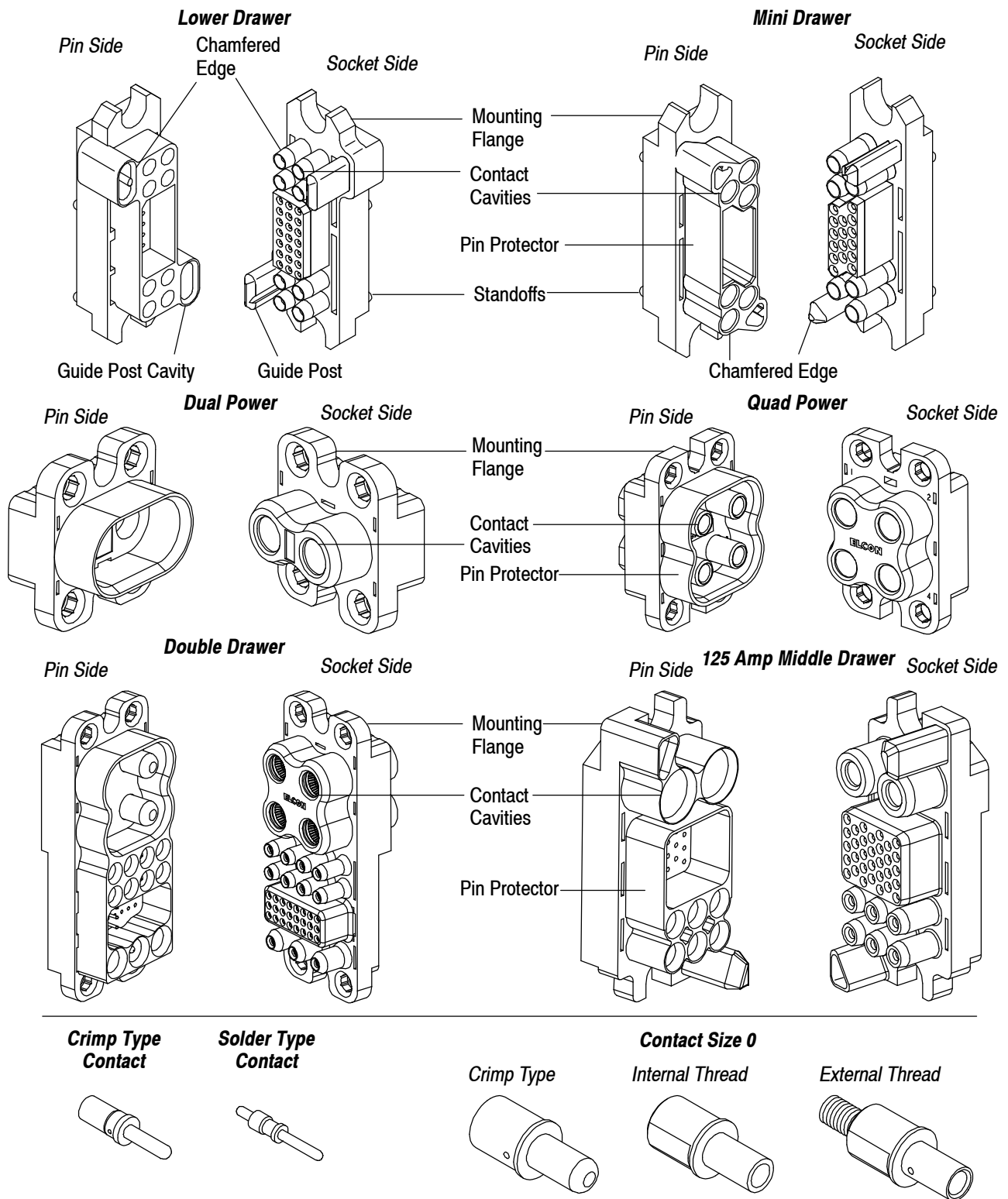


Figure 1 (end)

2. REFERENCE MATERIAL

2.1. Revision Summary

- Updated document to corporate requirements
- Added new information to Paragraph 3.7

2.2. Customer Assistance

Product Part Number 1648578 and Product Code D033 are representative numbers of the ELCON Drawer Series Connectors. Use of these numbers will identify the product line and expedite your inquiries through a service network established to help you obtain product and tooling information. Such information can be obtained through a local Tyco Electronics Representative or, after purchase, by calling the Product Information number at the bottom of page 1.

2.3. Drawings

Customer Drawings for product part numbers are available from the service network. If there is a conflict between the information contained in the Customer Drawings and this specification or with any other technical documentation supplied by Tyco Electronics, call Product Information at the number at the bottom of page 1.

2.4. Specifications

Product Specification 108-2285 provides product performance and test information. Workmanship Specification 101-654 is a guide for evaluating installed connectors for conditions which effect the cosmetics and/or function of the connector.

2.5. Manuals

Manual 402-40 is available upon request and can be used as a guide in soldering. This manual provides information on various flux types and characteristics along with commercial designations and flux removal procedures. A checklist is included in the manual as a guide for information on soldering problems.

2.6. Instructional Material

Instruction sheets (408-series) contain detailed assembly instructions and repair procedures for product and tooling. Documents available which pertain to this product are:

<u>Document Number</u>	<u>Document Title</u>
408-7516	Screw Machine Contacts and Application Tooling
408-10159	Insertion/Extraction Tools for ELCON Circular Contacts

3. REQUIREMENTS

3.1. Material

Crimp type contacts are made of copper alloy plated with silver or gold. Solder type contacts are made of brass or copper alloy plated with silver or gold. The crown band is made of copper alloy plated with gold over nickel. Hot plug contacts are made of copper alloy plated with gold. Connector housings are made of polyester, 30% glass filled, UL94-V0.

3.2. Storage

A. Ultraviolet Light

Prolonged exposure to ultraviolet light may deteriorate the chemical composition used in the connector material.

B. Shelf Life

The connectors should remain in the shipping containers until ready for use to prevent deformation to the contacts. The connectors should be used on a first in, first out basis to avoid storage contamination that could adversely affect signal transmissions. The shelf life is six months from date of shipment.

NOTE *Silver-plated contacts are shipped in silver-saver packaging to prevent tarnishing until opened.*



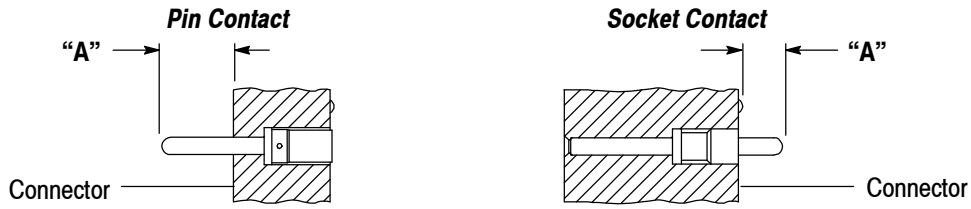
3.3. Chemical Exposure

Do not store connectors near any chemical listed below as they may cause stress corrosion cracking in the contacts.

Alkalies	Ammonia	Citrates	Phosphates	Citrates	Sulfur Compounds
Amines	Carbonates	Nitrites	Sulfur	Nitrites	Tartrates

3.4. Special Features

The length of the pin contacts (except size 0 and 4), designated by standard, pre-mate, and post-mate, varies among contact sizes and applies to the portion of the contact that protrudes from the connector after insertion (socket length does not include depth of the connector standoff). Mating socket contacts accept all pin lengths of the same contact size. The length of pin and socket contacts, as described, are shown in Figure 2.



CONTACT SIZE	CONTACT LENGTH (DIMENSION "A")			
	PIN			SOLDER TYPE CONTACT
	PROBE PROOF CRIMP TYPE AND SOLDER TYPE			
	(STANDARD)	PRE-MATE	POST-MATE	
20	8.12 [.320]	11.93 [.470]	6.85 [.270]	4.06 [.160]
16	8.38 [.330]	12.19 [.480]	7.36 [.290]	4.06 [.160]
12●	10.92 [.430]	11.68 [.460]	9.90 [.390]	5.33 [.210]
8	10.92 [.430]	12.19 [.480]	---	6.85 [.270]
4	12.95 [.510]	---	---	---
0	10.92 [.430] Probe Proof	Probe Proof	---	---
	12.57 [.495]	---		

●Includes hot plug contacts

Figure 2

Probe-proof socket contacts size 0 are designed with a protective cap to provide additional probe-proof protection along with the crown band. This cap must not be removed from the contact. See Figure 3.

Some crimp type contacts feature a sight hole located on the side of the wire barrel or in the center of the inside of the wire barrel. See Figure 3. Crimp contacts are rear-insertable and removable. PC board tail are rear-insertable and non-removable.

The connector contact cavities contain retention clips. The retention clip is an important feature in holding the crimped contact in the connector. When the contact is fully inserted, the retention clips engage the shoulder of the contact and prevent backing out during mating of the connector.

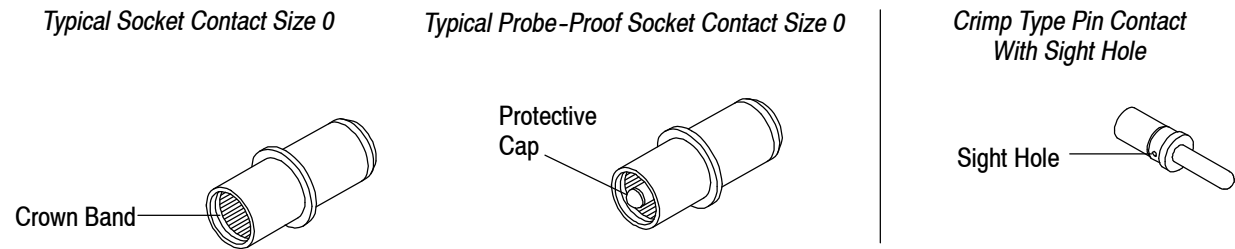


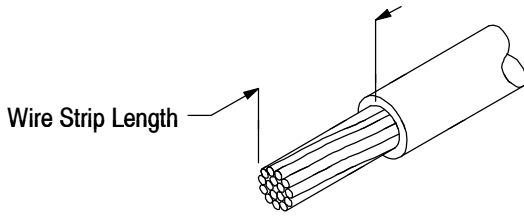
Figure 3

3.5. Wire Selection and Preparation

The contacts will accept stranded wire sizes 24 through 1/0 AWG. Proper strip length is necessary to properly insert the wire into the contact. The strip length of the wire is shown in Figure 4.



Reasonable care must be taken not to nick, scrape, or cut any strands during the stripping operation.



Note: Not to Scale

• Refer to MS 3348, "Contact Bushing, Electrical, Wire Barrel"

CONTACT SIZE	WIRE SIZE RANGE (AWG)	WIRE SIZE RANGE (mm ²)	WIRE STRIP LENGTH ±0.51 [±.020]
20	24-20	0.241-0.616	5.33 [.210]
16	18-16	0.963-1.23	6.86 [.270]
12	14-12	1.94-2.98	6.86 [.270]
8	10-8●	4.74-8.61	12.7 [.500]
4	6-4●	21.60	12.7 [.500]
0	1/0	53.00	15.2 [.600]

Figure 4

3.6. Crimp Type Contacts

Crimp contact to wire according to instructions packaged with applicable tooling. These requirements apply equally to the pin contact and the socket contact.

A. Wire Barrel Crimp

The crimp applied to the wire barrel portion of the contact is the most compressed area and is most critical in ensuring optimum electrical and mechanical performance of the crimped contact. The wire insulation must not enter the contact wire barrel. The crimp height is controlled by proper use of MIL-DTL-22520 crimp tooling. Refer to Section 5, TOOLING for tooling information.



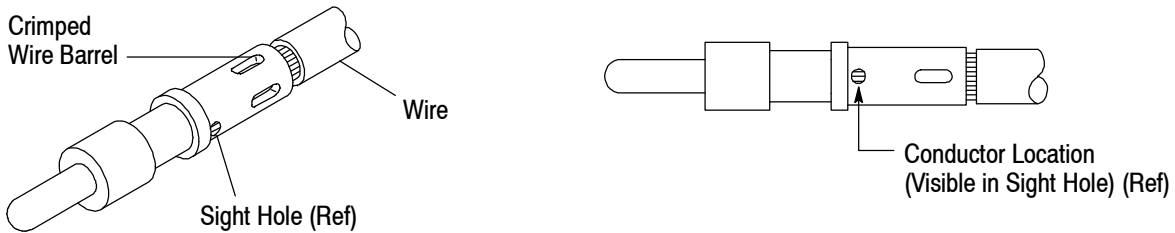
Reasonable care must be taken not to cut or break the wire insulation during the crimping operation.

B. Tensile Strength

Crimped splices must hold the wire firmly and have a crimp pull-out test value meeting that specified in Figure 5 (the test value is that of the smallest wire size used in the contact).



Adjust tensile testing machine for head travel of 25.4 mm [1.0 in.] per minute. Directly and gradually apply force for one minute.



WIRE SIZE (AWG)	TENSILE STRENGTH WITH SILVER PLATED COPPER WIRE (N [lbs])	TOOL SELECTOR	WIRE BARREL EFFECTIVE CRIMP LENGTH (Max)
20	89 [20]	4	3.30 [.130]
16	222 [50]	6	
12	489 [110]	8	
8	979 [220]	---	5.33 [.210]
4	1779 [400]		
1/0	3114 [700]		

Figure 5



Each crimp dimension represents the functional range of wire and contact combination. The developed crimp configuration is unique for each tool design and is acceptable provided the crimp height is within the functional range. For crimp dimensions relating to a specific tool, refer to the instruction sheet packaged with manual tools and the applicator log packaged with power tools.

C. Conductor Location

After crimping, the conductor ends must be flush to the end of the wire barrel. In contacts having a sight hole, this can be verified by checking that the conductor ends are visible in the sight hole. See Figure 5.

D. Effective Crimp Length

The effective crimp length is the area where the crimp pressure is applied over the length of the wire barrel.

E. Straightness

After crimping the wire to the contact, the contact must be chucked, and rotated a minimum of 360°. The point of TIR (total indicator reading) measurement must not exceed the dimensions shown in Figure 6.

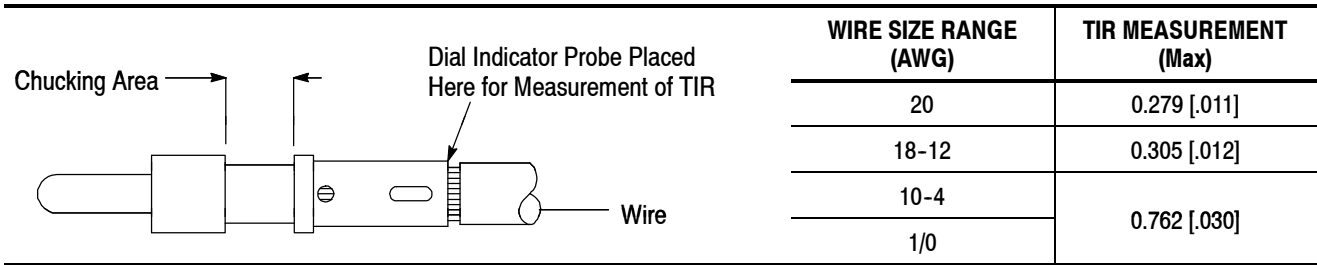


Figure 6

3.7. Threaded Contacts and Guide Posts and Threaded Contacts

- Threaded guide posts should not exceed a torque limit of 1.7 N•m [15 in.-lb]
- Threaded contacts with M6 threading should not exceed a torque limit of 4.5 N•m [40 in.-lb]
- Threaded contacts with 1/4–20 threading should not exceed a torque limit of 6.8 N•m [60 in.-lb]
- Threaded contacts with M5 threading should not exceed a torque limit of 2.9 N•m [26 in.-lb]

3.8. Connector Spacing

Care must be taken to avoid interference between adjacent connectors and/or other components. There is no required spacing between connectors, however spacing may be dependent on variable hardware used and the clearance required for mating connectors.

3.9. Panel Cutout

The pin side connector and socket side connector can be installed or removed from either the back or the front of the panel (front of the panel is recommended). Usually, the socket side connector is mounted in the cabinet (energized) panel, while the pin side connector is mounted in the drawer (passive) panel. Dimensions for mounting holes, guide pins (if applicable), and panel cutouts, and maximum panel thickness for rear mounting are shown in Figure 7.

3.10. Contact Insertion and Extraction

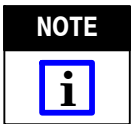
Normally an insertion tool is not required to insert contacts into connectors, but if the wire bundle is large or individual wires are fragile, using an insertion tool is recommended. Push contact straight into the contact cavity until it bottoms (an audible click). After inserting contact into connector, pull back lightly on the wire to ensure contact is fully seated.

The contacts are rear-insertable and rear-releasable; an extraction tool is needed to disengage the connector retention clips and remove the contact from the back of the connector. Only crimp type and threaded contacts are removable. Refer to Section 5 for tooling information.

3.11. PC Board Connectors

A. PC Board Material and Thickness

The pc board material shall be glass epoxy (FR-4 or G-10). The pc board thickness range shall be 1.38 through 5.08 mm [.054 through .200 in.].



Contact the Product Information Center at the number listed at the bottom of page 1 for suitability of other board materials and thicknesses.

B. PC Board Tolerance

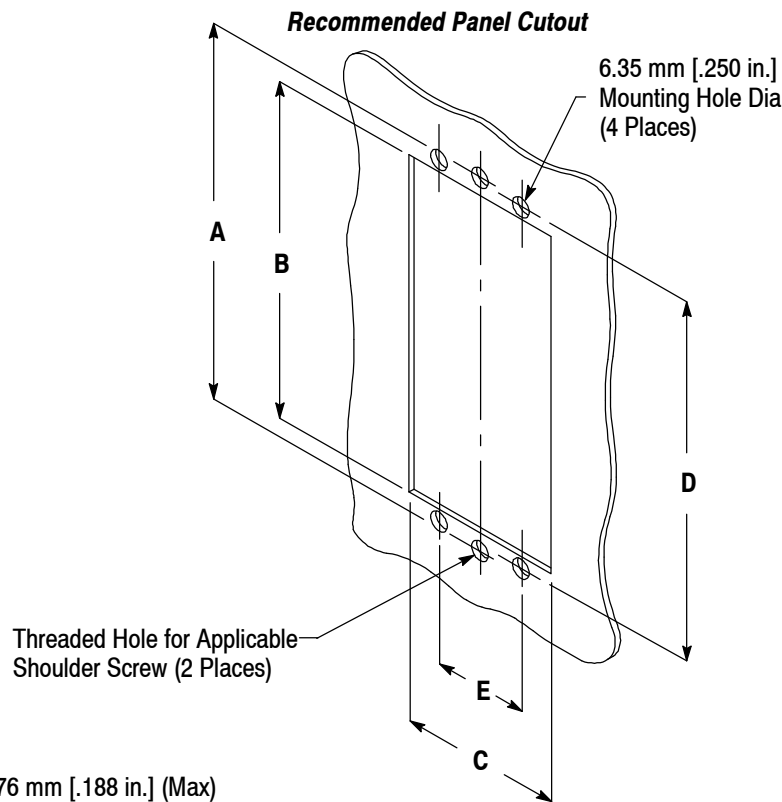
Maximum allowable bow of the pc board shall be 0.03 mm [.001 in.] over the length of the connector.

C. Connector Placement

The connector number one position must be aligned with the number one position board hole. When placing connectors on the pc board, make sure that the contact solder tails are aligned and started into the matching holes before seating the connector onto the pc board.



Connectors should be handled only by the housing to avoid deformation, contamination, or damage to the contact solder tails.



Panel Thickness: 4.76 mm [.188 in.] (Max)

CONNECTOR	A	B	C	D	E
QUADPOWER	53.98 [2.125]	43.18 [1.700]	43.18 [1.700]	50.80 [2.000]	24.89 [.980]
DUALPOWER	35.56 [1.400]	25.40 [1.000]	43.18 [1.700]	33.02 [1.300]	24.89 [.980]
TOP DRAWER, DOUBLE DRAWER	98.29 [3.870]	88.90 [3.500]	43.18 [1.700]	95.25 [3.750]	24.89 [.980]
125A MIDDLE DRAWER	72.01 [2.835]	62.99 [2.480]	35.56 [1.400]	---	---
75A MIDDLE DRAWER	76.20 [3.000]	67.31 [2.650]	36.83 [1.450]	---	---
LOWER DRAWER	76.20 [3.000]	66.67 [2.625]	25.40 [1.000]	---	---
MINI DRAWER	69.75 [2.746]	58.55 [2.305]	23.62 [.930]	---	---

Figure 7



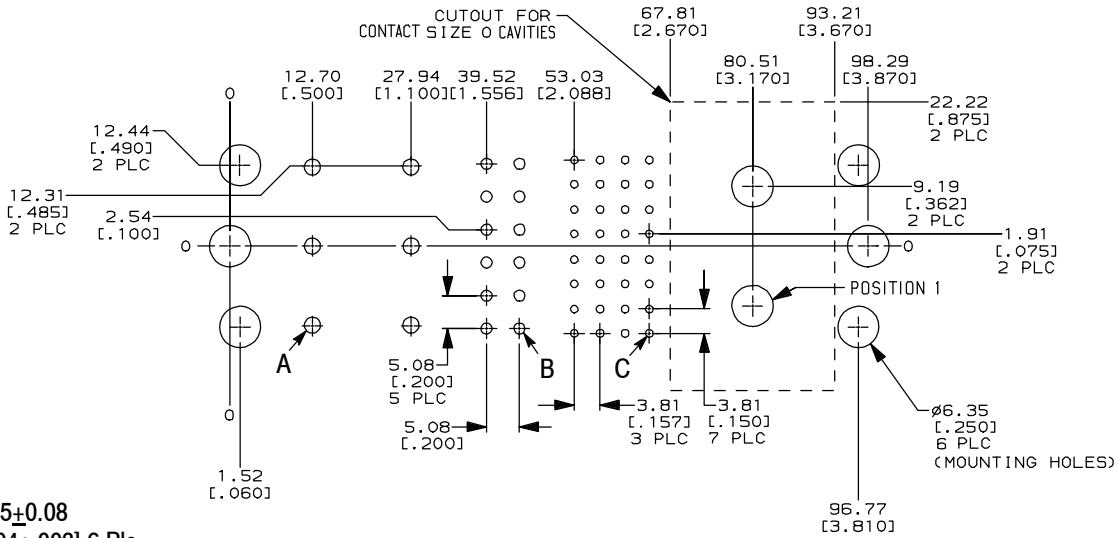
For applications using panel mounted threaded fasteners, care must be taken that the threaded hole does not compromise the shoulder area of the shoulder screw used to fasten the float mount connector.

D. PC Board Layout

The mounting holes and contact holes in the pc board must be precisely located to ensure proper placement and optimum performance of the connector. Design the pc board using the dimensions provided in Figure 8.

Recommended PC Board Layout

Top Drawer Pin Side



- A = 2.65±0.08
[.104±.003] 6 Plc
- B = 1.78±0.08
[.070±.003] 12 Plc
- C = 1.19±0.08
[.047±.003] 32 Plc

Top Drawer Socket Side

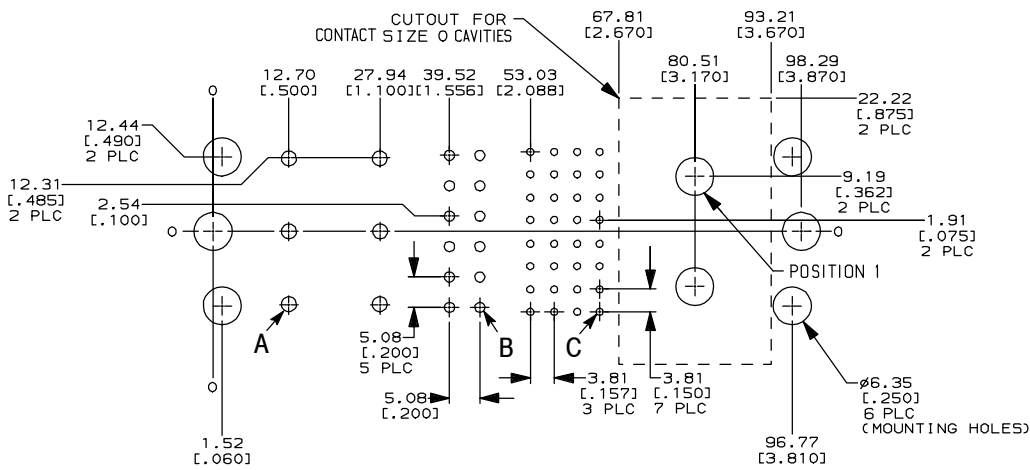


Figure 8 (cont'd)

75A Middle Drawer
Socket Side

75A Middle Drawer
Pin Side

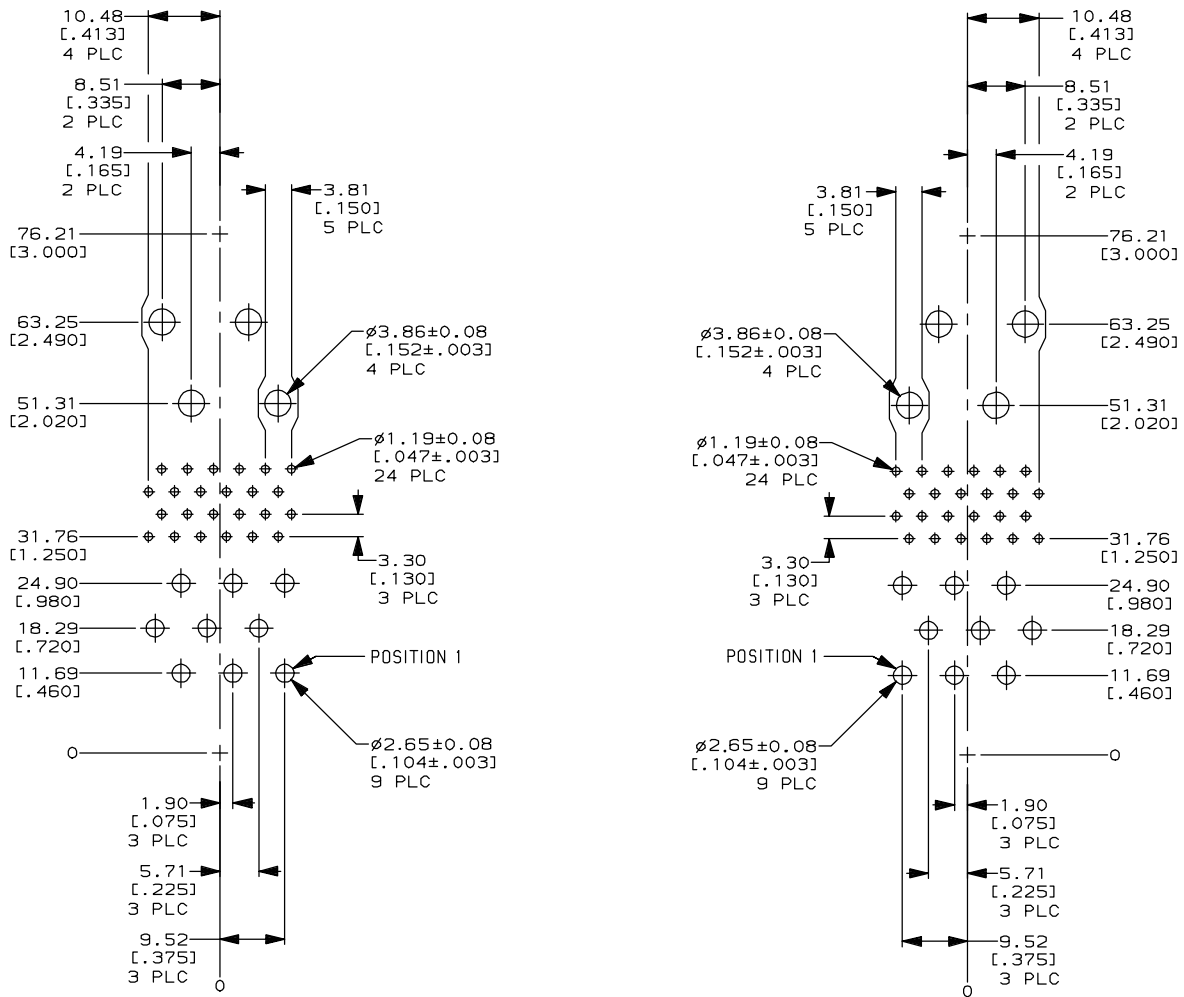
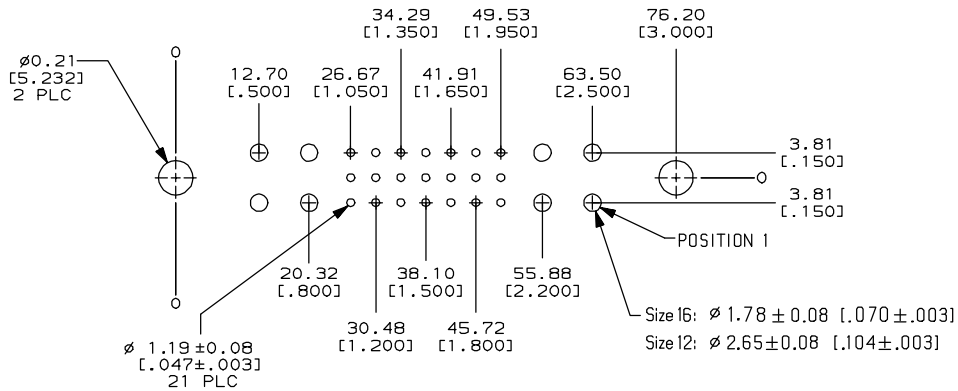
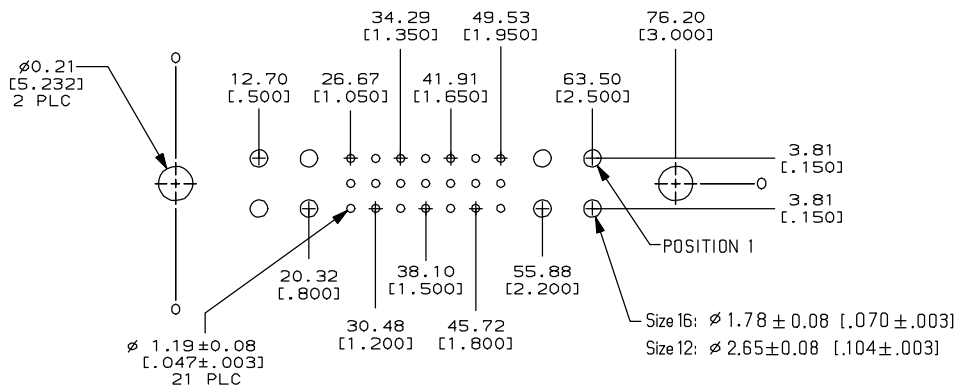


Figure 8 (cont'd)

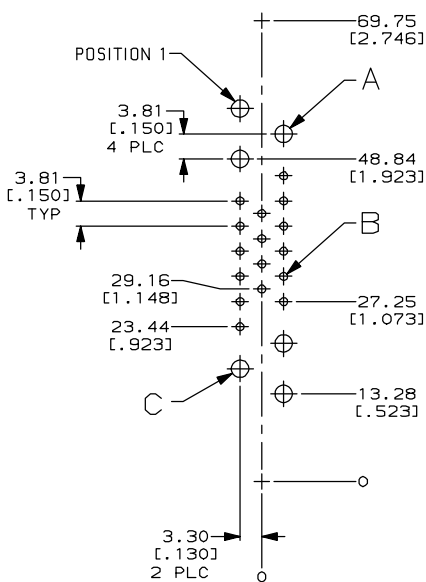
**Lower Drawer
Pin Side**



**Lower Drawer
Socket Side**



**Mini Drawer
Pin Side**



**Mini Drawer
Socket Side**

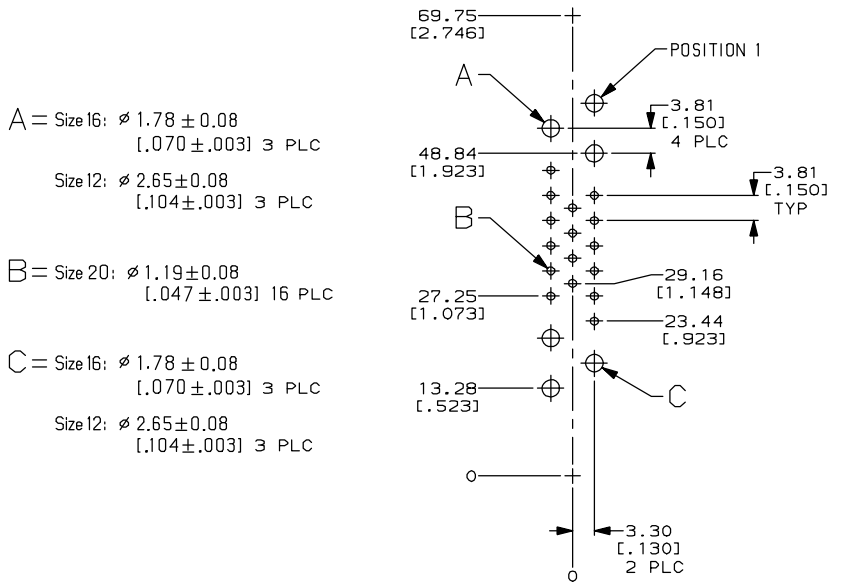


Figure 8 (cont'd)

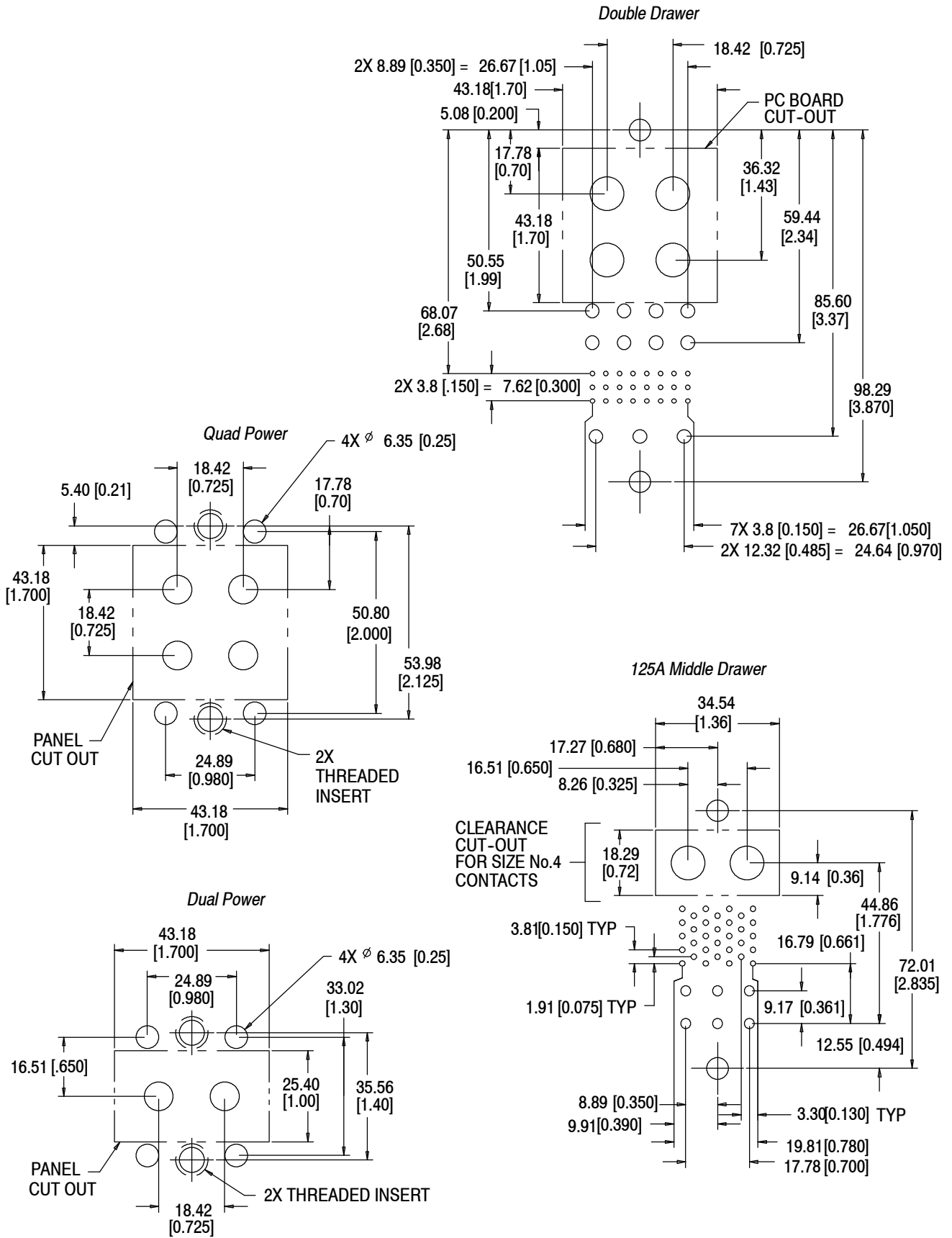
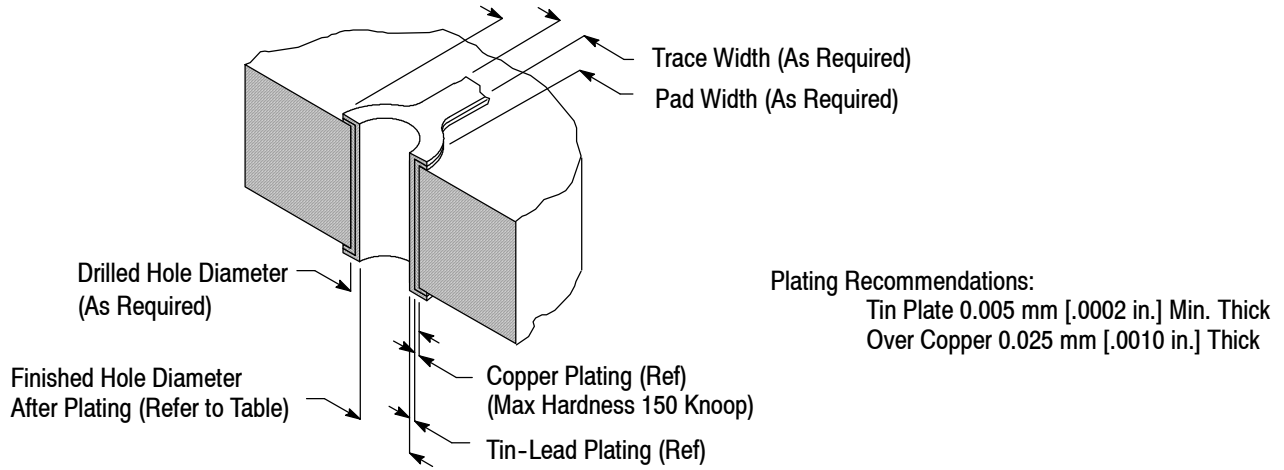


Figure 8 (end)

E. PC Board Hole Dimensions

The solder type contacts may be used with or without plated through holes. If plated, the drilled hole size, plating types, and plating thickness are dependent on the application requirements. The finished hole size must be as stated to provide unrestricted insertion and ensure adequate application of solder to the solder tines. See Figure 9.



CONTACT SIZE	FINISHED HOLE DIAMETER (± 0.08 [$\pm .003$])
20	1.20 [.047]
16	1.80 [.070]
12	2.65 [.104]
8	3.82 [.152]

▪Includes hot plug contacts

Figure 9

3.12. Connector Seating

The connector standoffs must be seated on the pc board or panel not exceeding the dimension shown in Figure 10.

NOTE *Hold-downs may be used to ensure stability during the soldering procedure.*

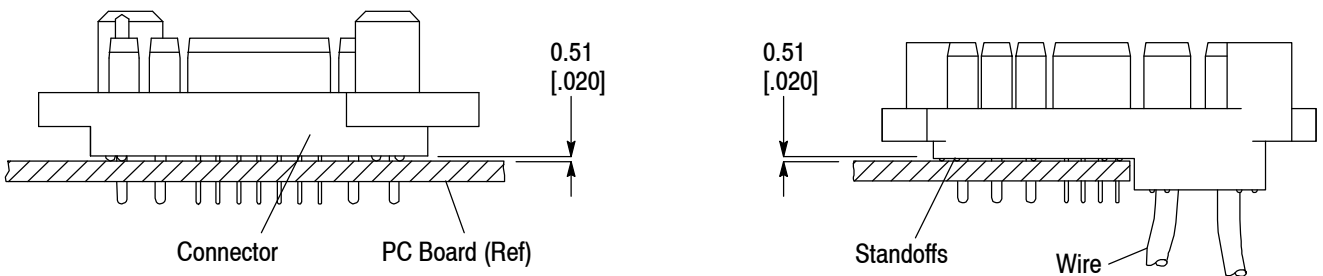


Figure 10

3.13. Soldering

Observe guidelines and procedures when soldering contacts is required. All solder joints should conform to those specified in Workmanship Specification IPC-A-610 and all other requirements specified in this document. Contacts must be stabilized during soldering with a non-metallic material. Solder, clean, and dry all wire leads to contacts according to the following:

A. Flux Selection

Wire lead and contact wire barrel interior shall be fluxed prior to soldering using a mildly active rosin. Flux must be compatible with manufacturing, safety, and health guidelines.

B. Cleaning

After cleaning, removal of fluxes, residues, and activators is mandatory. Cleaning procedures and solvents depend on the type of flux used. See Figure 11.



Consideration must be given to toxicity and other safety and health requirements as recommended in the Material Safety Data Sheet supplied by the solder cleaning solvent manufacturer.

CLEANER		TIME (Minutes)	TEMPERATURE (Maximum)	
NAME	TYPE		CELSIUS	FAHRENHEIT
ALPHA 2110	Aqueous	1	132	270
BIOACT EC-7	Solvent	5	100	212
Butyl CARBITOL	Solvent	1	Ambient Room	
Isopropyl Alcohol	Solvent	5	100	212
KESTER 5778	Aqueous	5	100	212
KESTER 5779	Aqueous	5	100	212
LONCOTERGE 520	Aqueous	5	100	212
LONCOTERGE 530	Aqueous	5	100	212
Terpene Solvent	Solvent	5	100	212

Figure 11

C. Drying

When drying cleaned connector assemblies, make certain that the recommended temperature limitations of -40 to +105°C [-40 to +221°F] are not exceeded. Excessive temperatures may cause housing degradation.

3.14. Connector Loading

These connectors provide optimum mapping of pin to function, and ease of routing in the system by accepting various contact sizes, quantities, and types. All connector contact positions accept crimp type and solder type terminations. In addition, high power connectors accept threaded contacts (size 0 only). Possible contact options for loading individual connectors are shown in Figure 12.

CONNECTOR	CONTACTS						CONNECTOR RATING
	0	4	8	12	16	20	
DOUBLE DRAWER	4	---	---	11	---	24	150A/200A†
TOP DRAWER	2	---	---	6	12	32	150A/200A†
125 MIDDLE DRAWER	---	2	---	6	---	32	125A
75A MIDDLE DRAWER	---	---	4	9	---	24	75A
LOWER DRAWER■	---	---	---	8	---	21	35A
	---	---	---	4	4	21	
	---	---	---	---	8	21	
MINI DRAWER▲	---	---	---	6	---	16	35A
	---	---	---	3	3	16	
	---	---	---	---	6	16	
DUALPOWER	2	---	---	---	---	---	150A/200A†
QUADPOWER	4	---	---	---	---	---	150A/200A†

† 200A when mounted on bus bar. ■ Three Lower Drawer housing variations with different combinations of contact size 12 and 16 are available. ▲ Three Mini Drawer housing variations with different combinations of contact size 12 and 16 are available.


Figure 12

3.15. Mounting Hardware

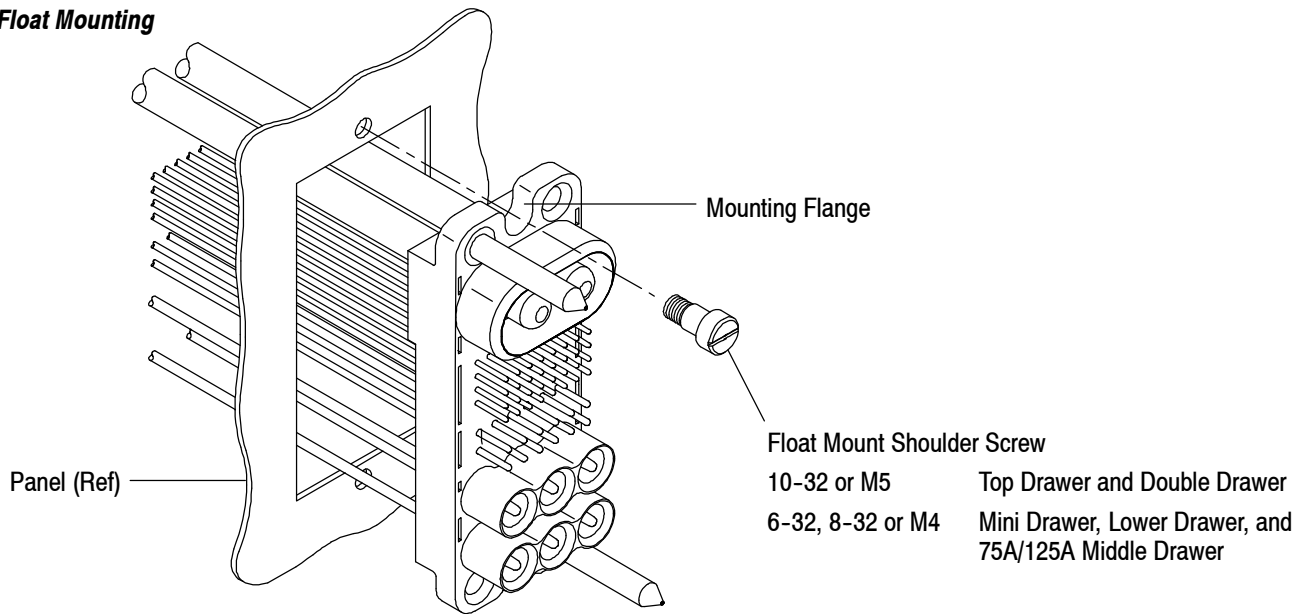
The connectors can be float mounted or fixed mounted to a backplane or chassis. The float mount shoulder screws are designed to secure a connector to a panel. The panel must flex and be of sufficient gauge to support mating loads. These screws allow some movement of the assembly for easier mating.

Connectors can be fixed mounted using commercially available screws with a head that will not interfere with connector mating. Washers can also be used to make up the difference for the required hardware diameter. High power connectors are fixed mounted using the mounting flange or, if available, the guide pins (which have internal 6-32 threads). Hardware for specific connector types is shown in Figure 13.

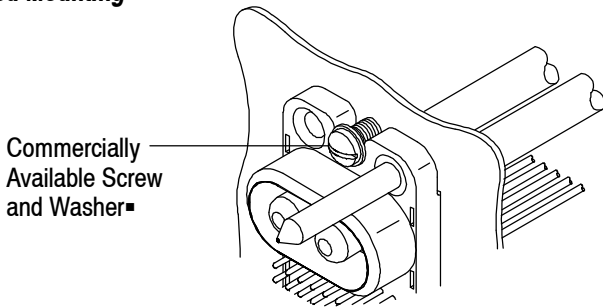
NOTE *PC board connectors must be fixed mounted.*



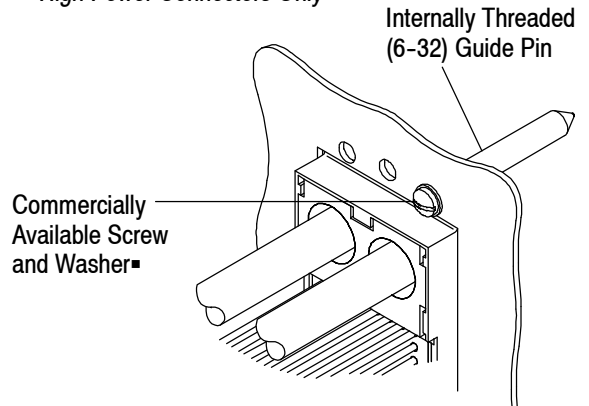
Float Mounting



Fixed Mounting



Optional Fixed Mounting for High Power Connectors Only



- Hardware Diameter
 - 9.52 mm [.375 in.] Top Drawer, Double Drawer
 - 12.7 mm [.500 in.] 75A, 125A Middle Drawer, Lower Drawer and Mini Drawer

Figure 13

3.16. Connector Mating and Alignment

The pre-installed guide pins and molded-in guide posts ensure positive mating of connectors. In addition, because of their symmetrical design, the low power connectors have a polarizing feature: a rib in the guide post cavity that fits into a notch in the guide post. When fully engaged, the dimension between the pin side connector and socket side connector must be within the limit provided to ensure full mating. See Figure 14.

When mounted, the float mount design allows blind mating with gatherability up to 2.54 mm [.100 in.].

Low Power Connectors
Polarizing Feature

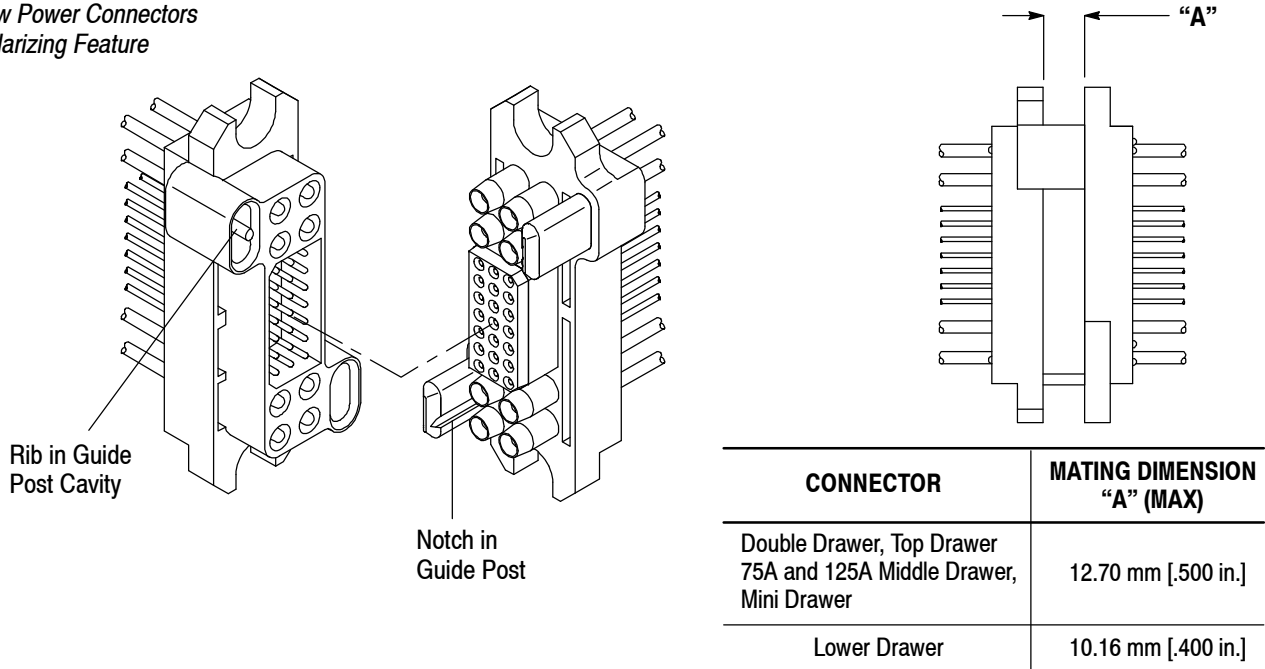


Figure 14

3.17. Special Assembly Consideration

The system into which the connectors are installed must support the weight of the drawer when connectors are engaged (for example, the drawer must bottom on a built-in stop, not on the connector).

3.18. Strain Relief and Wire Dress

If required, wires can be bundled together and supported with cable ties. Wires must not be stretched or confined in any way that would restrict the floating action of the connectors. Therefore, the wires must remain perpendicular to the connector and avoid an excessively sharp bend radius. The minimum distance for the cable tie, measured from the wire end of the connector to the cable tie, and the minimum bend radius of a wire bundle is shown in Figure 15.

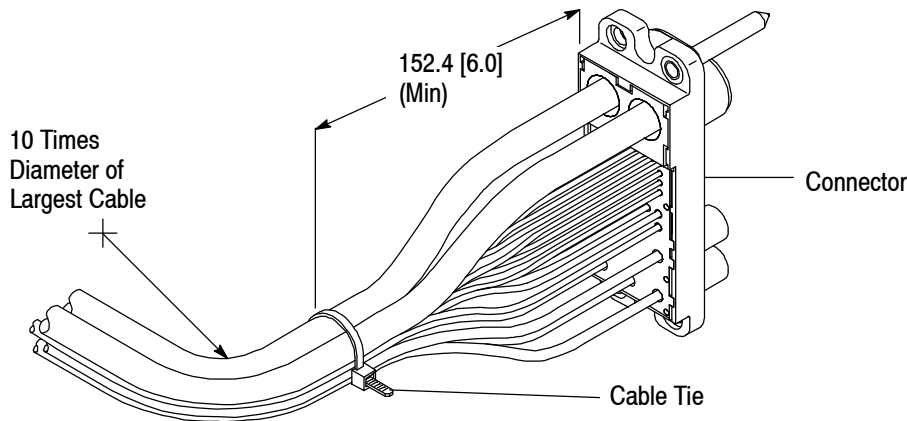


Figure 15

3.19. Repair

Damaged connectors must be removed, discarded, and replaced. Connectors with solder type contacts will require desoldering of all contact solder tails. Solder type contacts are not removable from the housing assembly.

Damaged crimp type contacts must be removed from the connector, discarded, and replaced with new ones.



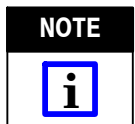
Damaged product should not be used. If a damaged contact is evident before the contact is inserted into the housing, cut the wire in back of the contact and re-terminate the wire end. If contact is damaged after insertion, remove the contact with the extraction tool and cut the wire in back of the contact and re-terminate wire end.

4. QUALIFICATIONS

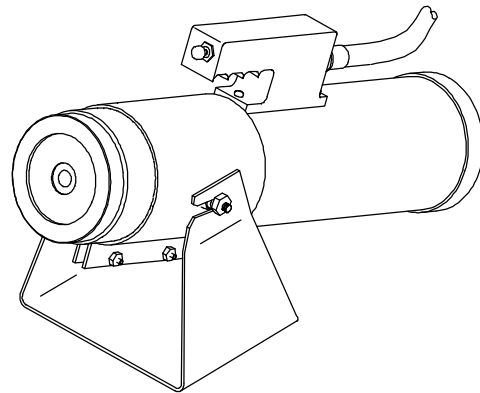
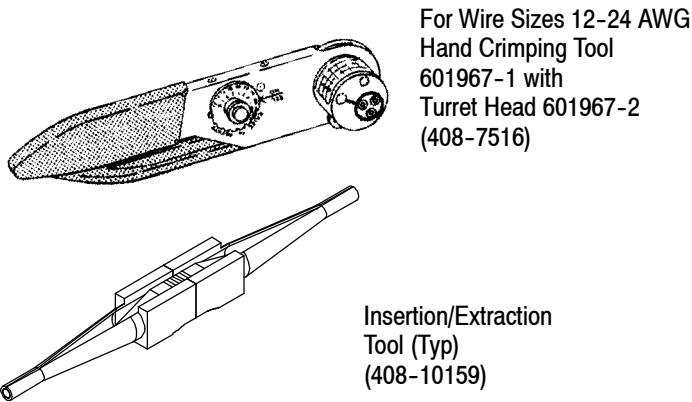
ELCON Drawer Series Connectors and Contacts are Recognized by Underwriters Laboratories Inc. (UL)/CSA International in File E28476.

5. TOOLING

Hand and pneumatic crimping tools that accommodate the full wire size range are designed for terminating crimp type contacts. The insertion/extraction tools are designed to insert and remove crimp type and threaded contacts from connectors. The tool depresses the connector internal retention clips without deforming them. Tooling part numbers and instructional material packaged with the tooling are shown in Figure 16.



Military standard Daniels bench mount crimping machine is applicable for terminating crimp type contacts. This machine has been designed to form indents to the proper depth in the contact wire barrel. It requires a specially designed funnel which helps gather wire strands and guide them into the closed barrel of the contacts. It is designed for production requirements. Refer to Figure 16.



For Wire Sizes 1/0 and 8 AWG
Daniels Heavy Duty Pneumatic Bench Machine
M22520/23-01 with:
Wire Size 8 AWG
Daniels Indentor Head M22520/23-02
Daniels Locator M22520/23-09
Wire Size 1/0 AWG
Daniels Indentor Head M22520/23-05
Daniels Locator M22520/23-13
Wire Size 4 AWG
Daniels Indentor Head M22520/23-04
Daniels Locator M22520/23-11

PN	TOOL		CONTACT SIZE
	INSERTION TIP COLOR	EXTRACTION TIP COLOR	
1643914-1	---	Red	8
1643915-1	Yellow	White	12
1643916-1	Blue	White	16
1643917-1	Red	White	20
1643921-1	---	Yellow	0
1643922-1	---	Blue	4

Figure 16

6. VISUAL AID

Figure 17 shows a typical application of the ELCON Drawer Series Connectors. This illustration should be used by production personnel to ensure a correctly applied product. Applications which DO NOT appear correct should be inspected using the information in the preceding pages of this specification and in the instructional material shipped with the product or tooling.

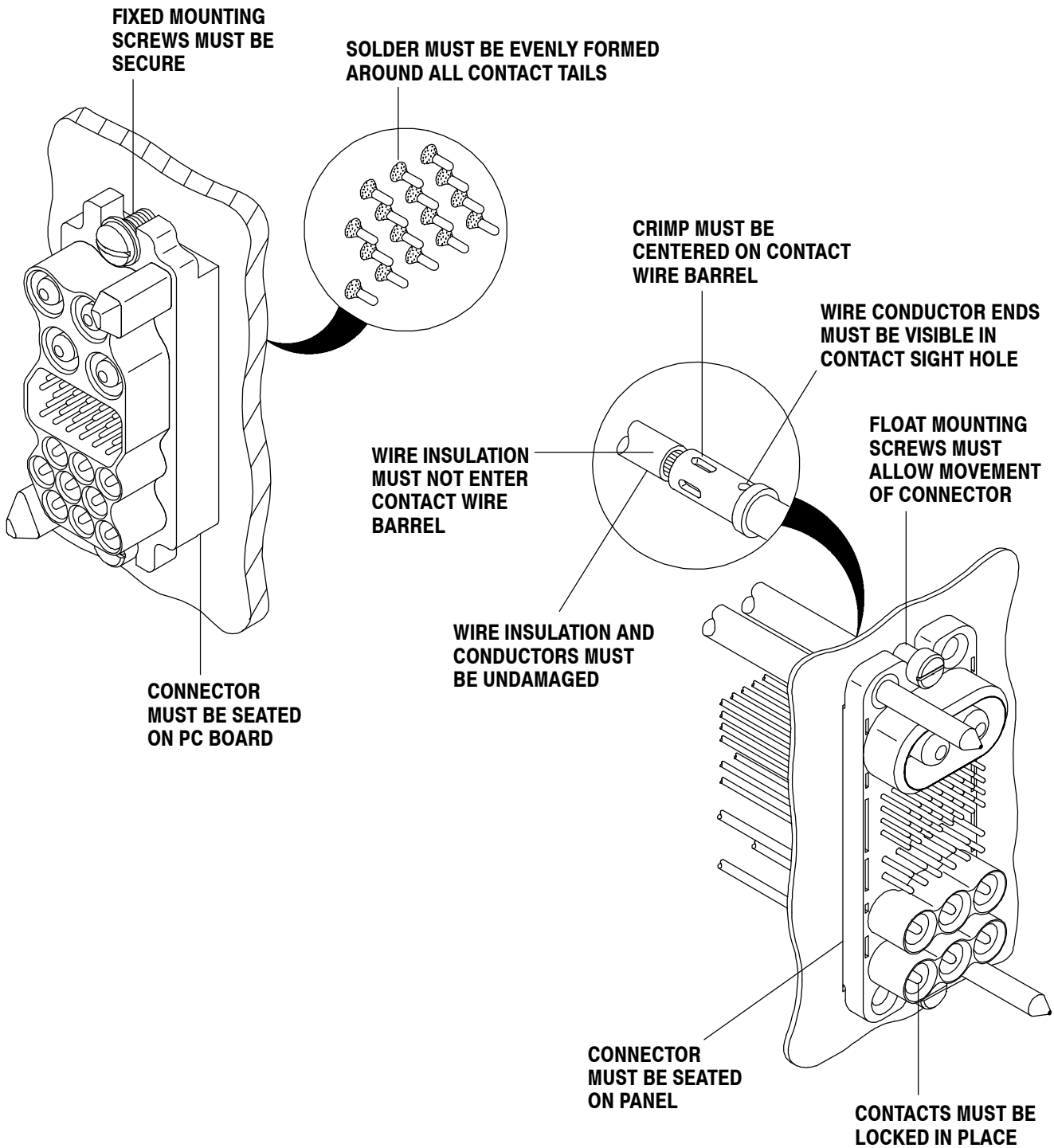


FIGURE 17. VISUAL AID