

# DPM 40

3½ Digit LED Module

A compact meter ideally suited to applications where excellent readability under all lighting conditions is required. The meter is fitted with high efficiency LEDs which, together with the integral red filter, give a high contrast display with 11mm / 0.43" digit height. The meter can be easily scaled by the user to indicate volts, amps or other engineering units and may be used in single-ended, differential or floating input modes.

- 🔊 11mm (0.43") Digit Height
- 🔊 Programmable Decimal Points
- 🔊 Auto-zero
- 🔊 Auto-polarity
- 🔊 200mV d.c. Full Scale Reading (F.S.R.)



## SCALING

Two resistors Ra and Rb may be fitted in order to alter the full scale reading (F.S.R.) of the meter - see table.

The meter will need re-calibration by adjusting the calibration potentiometer.

Required F.S.R.		Ra	Rb
2V	Note	910k	100k
20V	Note	1M	10k
200V	Note	1M	1k
2kV	Note	1M	100R
200µA		LINK	1k
2mA		LINK	100R
20mA		LINK	10R
200mA		LINK	1R

## NOTE

Ensure that solder link La across Ra is OPEN.

Standard Meter	Stock Number DPM 40			
Specification	Min.	Typ.	Max.	Unit
Accuracy (overall error) *		0.1		% (±1 count)
Linearity			±1	count
Sample rate		2.5		samples/sec
Operating temperature range	0		50	°C
Warm-up time		10		minute
Temperature stability		150		ppm/°C
Supply voltage (V+ to V-)	4.5	5	5.5	V
Supply current		50	90	mA
Input leakage current (Vin = 0V)		1	10	pA

\* To ensure maximum accuracy, re-calibrate periodically.

## SAFETY

To comply with the Low Voltage Directive (LVD 93/68/EEC), input voltages to the module's pins must not exceed 60Vdc. If voltages to the measuring inputs do exceed 60Vdc, then fit scaling resistors externally to the module. The user must ensure that the incorporation of the DPM into the user's equipment conforms to the relevant sections of BS EN 61010 (Safety Requirements for Electrical Equipment for Measuring, Control and Laboratory Use).

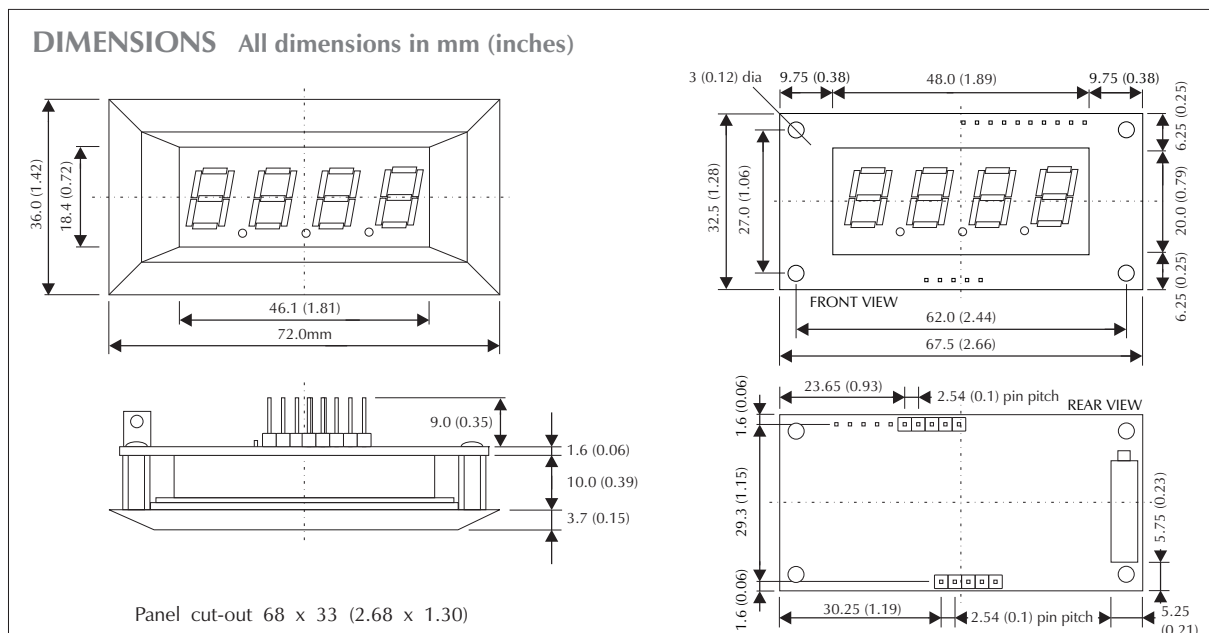

www.lascarelectronics.com

## PIN FUNCTIONS

1. +5V Positive power supply to the meter.
  2. COM The ground for the analogue section of the converter, held actively at 3.05V (nom) below +5V. This pin is for use only when the module is used with a fully floating supply.  
**It should on no account be connected to any other terminations or circuitry except as specified in the relevant operating modes.**
  3. IN HI Positive measuring input.
  4. IN LO Negative measuring input. } Analogue inputs must be no closer than 1.5V to the positive supply or lower than 3.5V below 0V.
  5. 0V Negative power supply to the meter.
  - A, A'. DP1 Connect to Pin E (DP COM) to display decimal point 1 (199.9).
  - B, B'. DP2 Connect to Pin E (DP COM) to display decimal point 2 (19.99).
  - C, C'. DP3 Connect to Pin E (DP COM) to display decimal point 3 (1.999).
  - D, D'. DE For normal use, do not connect. To use the Display Enable function, see notes on Solder Link DE, below.
  - E, E'. DP COM Connect to Pin A, B or C to select required DP.
- Note: Pins A' to E' are a factory fitted option.

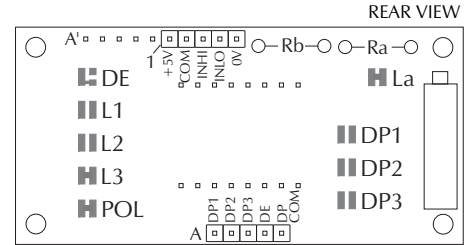

Component and Solder Link Lay-out

## SOLDER LINK FUNCTIONS

- La Normally closed. Open this link when fitting scaling resistor Ra.
- DE To use the Display Enable function, open the bottom half of the link and close the top half of the link. Leaving DE unconnected switches off the LED display, but the internal measurement circuit continues to operate, resulting in low current operation. Connecting DE (pin D(D')) to V+ switches on the LED display. The first displayed reading will be correct without the need for A/D settling time.
- L1 Normally open. Close this link to connect INLO (pin 4) to 0V (pin 5).
- L2 Normally open. Close this link to connect INLO (pin 4) to COM (pin 2).
- L3 Normally closed. This solder link is for factory use only.
- POL Normally closed. Open this link to disable to polarity sign (- sign)
- DP1 Normally open. Close this link to display decimal point 1 (199.9). This internally connects DP1 (pin A(A')) to DP COM (pin E(E')).
- DP2 Normally open. Close this link to display decimal point 2 (19.99). This internally connects DP2 (pin B(B')) to DP COM (pin E(E')).
- DP3 Normally open. Close this link to display decimal point 3 (1.999). This internally connects DP3 (pin C(C')) to DP COM (pin E(E')).

## VARIOUS OPERATING MODES

**ON-BOARD SOLDER LINKS:** In order to quickly and easily change operating modes for different applications the meter has several on-board solder links. They are designed to be easily opened (cut) or shorted (soldered). Do not connect more than one meter to the same power supply if the meters cannot use the same signal ground. Taking any input beyond the power supply rails will damage the meter.

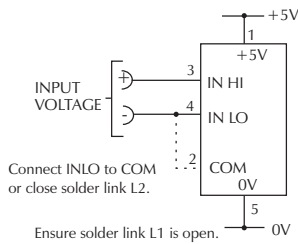

Operation with input floating with respect to power supply.

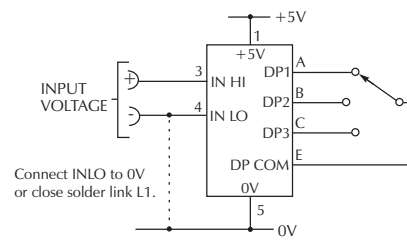

Operation with input referenced to panel meter supply.

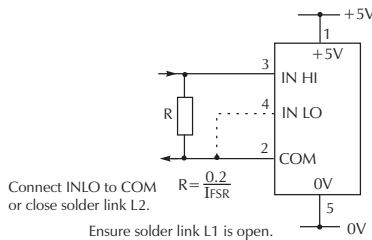

Measuring current.  
Meter power supply must be isolated from 4-20mA current loop.

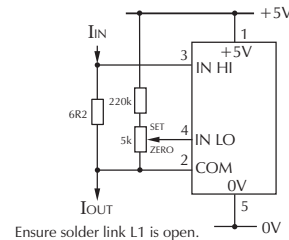

Measuring 4-20mA to read 0-999.  
Meter power supply must be isolated from 4-20mA current loop.