

DV6400TD Series Tubeaxial

Ø 172x160x51mm TURBOFAN



- DC diagonal fans with electronically commutated external rotor motor. Fully integrated commutation electronics.
- Metal fan housing, impeller of fiber-glass reinforced plastic PA.
- Mounting from either face using two 4.3 mm holes.
- Air exhaust over struts. Rotational direction CCW looking at rotor.
- Electrical connection via leads. AWG 22, TR 64. Stripped and tinned ends. Housing ground lug for screw M4 x 8 (TORX).
- UL, CSA, VDE approvals on most models, please contact application engineering.

Part Number	Curve	CFM @ 0	VDC	Volt. Range	Power (W)	dBA	Max Amb. Temp. C	Bearing Type	Speed (RPM)	Wgt. (lbs)
min ▼ max DV6424/2TDP-815	1	58.9	24	16 to 36	2.0	29	70	Ball	800	1.81
	2	400.2								
min ▼ max DV6448/2TDP-833	1	58.9	48	40 to 55	2.0	29	60	Ball	800	1.81
	2	400.2								

Temperature control available upon request.
Speed setting via control voltage or PWM signal available upon request.

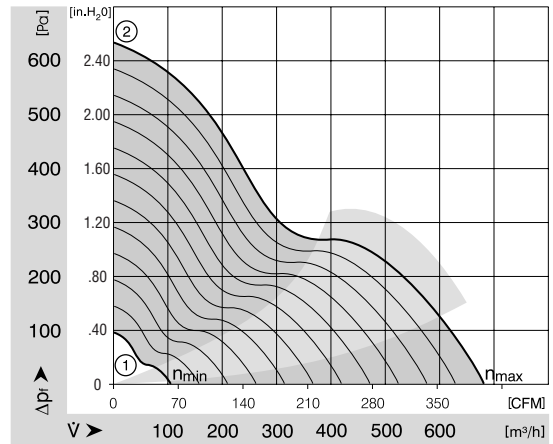
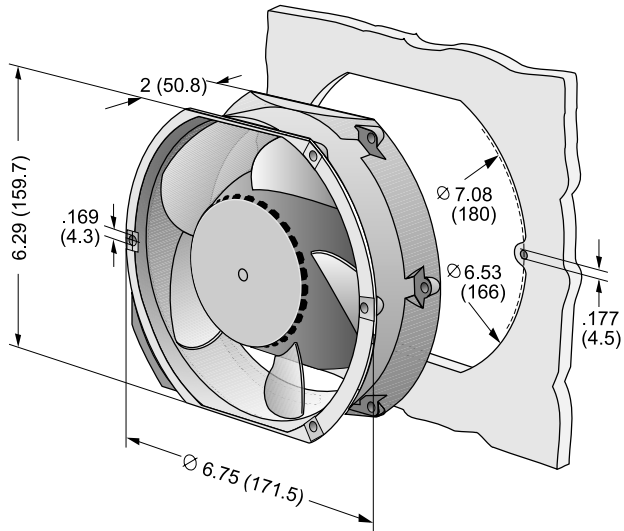

ebmpapst

e-mail: sales@us.ebmpapst.com · TEL: 860-674-1515 · FAX: 860-674-8536

ebm-papst Inc., 100 Hyde Road, Farmington, CT 06034 USA

ebm-papst Inc., 2006 © ebm-papst Inc. reserves the right to change any specifications or data without notice