

Matchable Pairs – Emitter and Detector

Description

Pairs of infrared-emitting diode and photologic detector, matched in their optical and electrical features. These pairs enable a lot of applications. They can be used both for transmissive or reflective sensor functions. The peak wavelength of the emitter is $\lambda = 950 \text{ nm}$. The detector consists of a photologic IC with Schmitt trigger and open collector output.

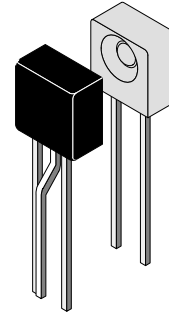

96 12366

Applications

- Detection of opaque material, documents etc
- Paper position sensor in copy machines
- Position sensor for shaft encoder

Features

- Output level 'LOW' when infrared beam is not interrupted
- TTL compatible
- Small dimensions
- Detector provided with daylight filter
- Emitter and detector in side view case
- Miniature plastic case with lens
- Operating angle $\pm \varphi = 35^\circ$

Handling Precautions

Connect a capacitor C of 100 nF between V_{S1} and ground in order to stabilize power supply voltage!

Order Instruction

Ordering Code	Remarks
TCZS8100-PAER	



Absolute Maximum Ratings

Input (Emitter)

Parameter	Test Conditions	Symbol	Value	Unit
Reverse voltage		V_R	6	V
Forward current		I_F	60	mA
Forward surge current	$t_p \leq 10$ s	I_{FSM}	3	A
Power dissipation	$T_{amb} \leq 25^\circ\text{C}$	P_V	100	mW
Junction temperature		T_j	100	$^\circ\text{C}$

Output (Detector)

Parameter	Test Conditions	Symbol	Value	Unit
Supply voltages range		V_{S1}	-0.5 to +16	V
		V_{S2}	20	V
Output current		I_O	20	mA
Power dissipation	$T_{amb} \leq 85^\circ\text{C}$	P_V	50	mW
Junction temperature		T_j	100	$^\circ\text{C}$

Emitter and Detector matched

Parameter	Test Conditions	Symbol	Value	Unit
Ambient temperature range		T_{amb}	-25 to +85	$^\circ\text{C}$
Storage temperature range		T_{stg}	-40 to +100	$^\circ\text{C}$
Soldering temperature	2 mm from case, $t \leq 5$ s	T_{sd}	260	$^\circ\text{C}$

Note: Operating conditions are stabilized after 100 μs of supply voltage turn on.

Electrical Characteristics ($T_{amb} = 25^\circ\text{C}$)

Input (Emitter)

Parameter	Test Conditions	Symbol	Min.	Typ.	Max.	Unit
Forward voltage	$I_F = 50$ mA	V_F		1.25	1.65	V
Junction capacitance	$V_R = 0$, $f = 1$ MHz	C_j		50		pF

Output (Detector)

Parameter	Test Conditions	Symbol	Min.	Typ.	Max.	Unit
Supply voltage range		V_{S1}	4.5		16	V

Emitter and Detector matched ¹⁾

Parameter	Test Conditions	Symbol	Min.	Typ.	Max.	Unit
Supply current	$V_{S1} = 16$ V	I_{S1}		3	5	mA
Output current	$V_{S1} = V_{S2} = 16$ V, $I_F = 0$	I_{OH}			1	μA
Input threshold current	$V_{S1} = 5$ V	I_{FT}		3	10	mA
Hysteresis	$V_{S1} = 5$ V	I_{Foff}/I_{Fon}		80		%
Output voltage	$I_{OL} = 16$ mA, $I_F > I_{FT}$, $V_{S1} = 5$ V			0.15	0.4	V
Switching frequency	$I_F = 3 \times I_{FT}$, $R_L = 1$ k Ω , $V_{S1} = V_{S2} = 5$ V	f_{sw}		200		KHz

¹⁾ Characteristics are measurement at a separation distance of 4 mm (1.55") within a common axis of 0.5 mm (0.02") and parallel within 5°

Switching Characteristics

Parameter	Test Conditions	Symbol	Typ.	Unit
Rise time	$V_{S1} = V_{S2} = 5\text{ V}$, $I_F = 3 \times I_{FT}$, $R_L = 1\text{ k}\Omega$ (see figure 1)	t_r	50.0	ns
Turn-on time		t_{on}	1.0	μs
Fall time		t_f	20.0	ns
Turn-off time		t_{off}	3.0	μs

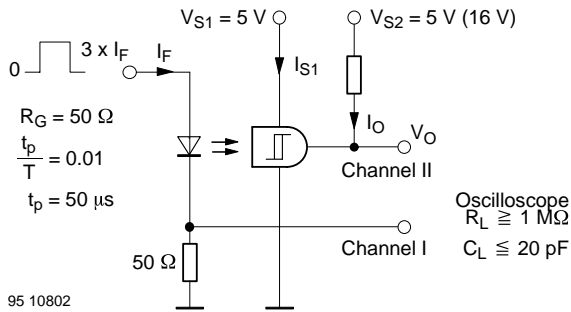

Figure 1. Test circuit

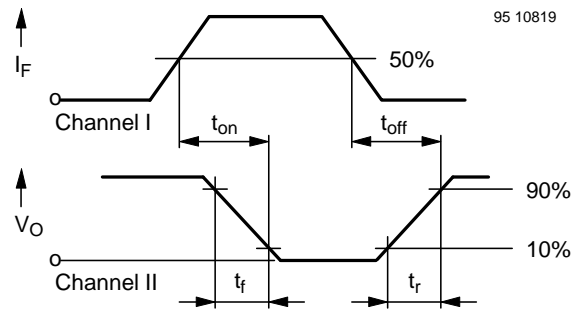

Figure 2. Pulse diagram

Typical Characteristics ($T_{amb} = 25^{\circ}\text{C}$, unless otherwise specified)

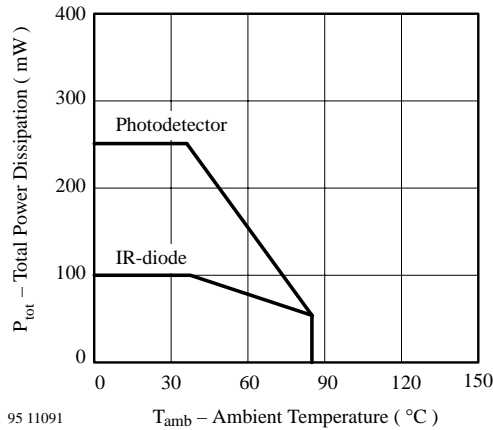

Figure 3. Total Power Dissipation vs. Ambient Temperature

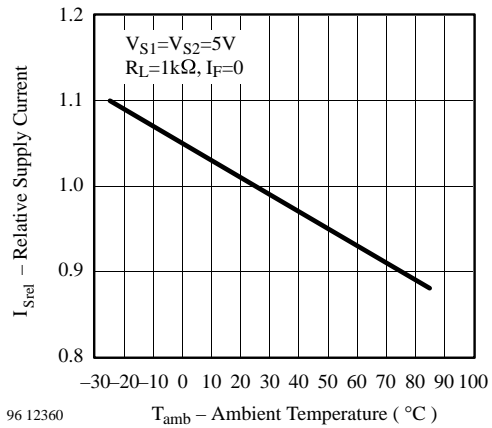

Figure 6. Relative Supply Current vs. Ambient Temperature

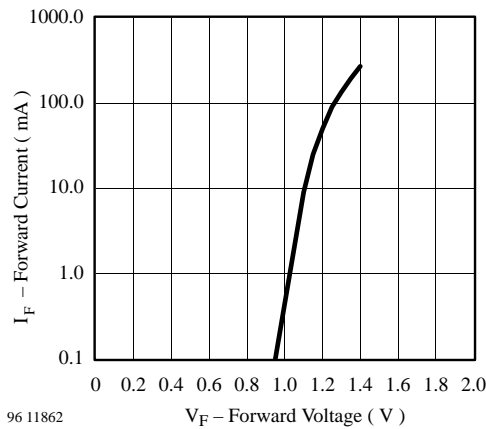

Figure 4. Forward Current vs. Forward Voltage

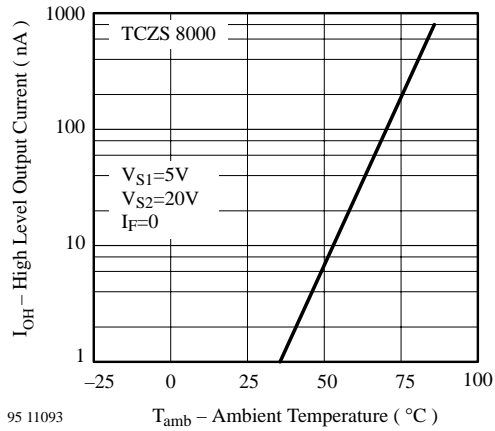

Figure 7. High Level Output Current vs. Ambient Temperature

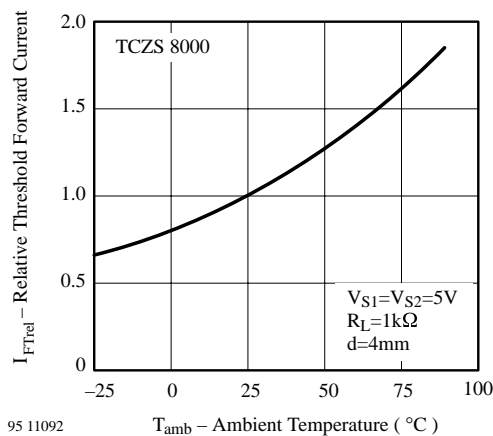
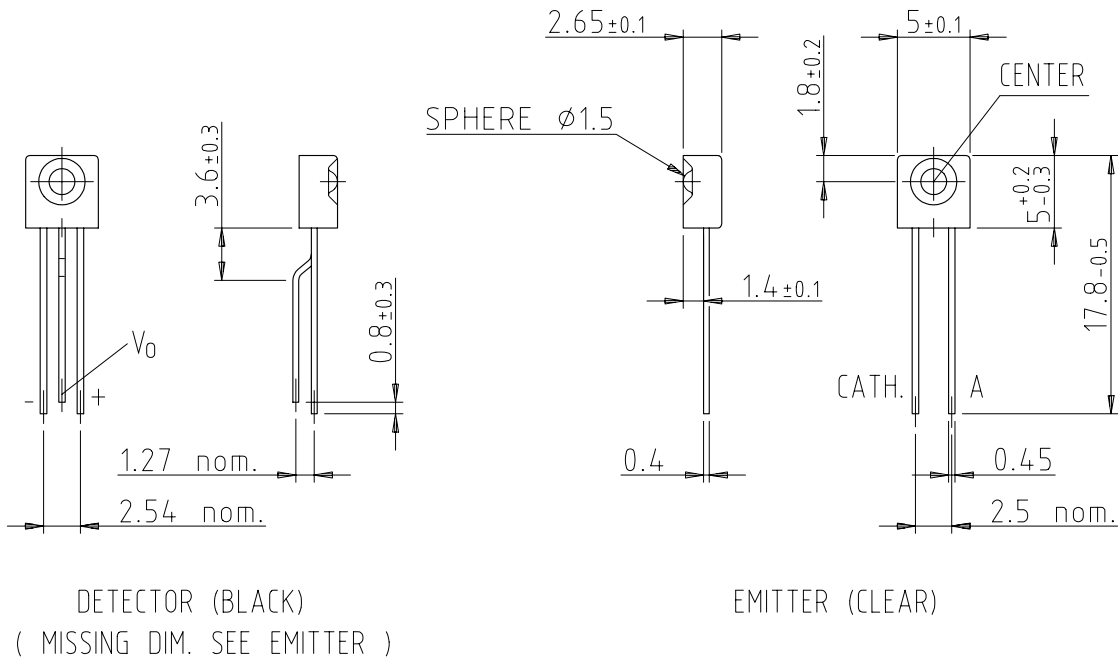

Figure 5. Relative Threshold Forward Current vs. Ambient Temperature

Dimensions of TCZS8100 in mm



weight: ca. 0.25g

96 12104

technical drawings
according to DIN
specifications



Ozone Depleting Substances Policy Statement

It is the policy of **Vishay Semiconductor GmbH** to

1. Meet all present and future national and international statutory requirements.
2. Regularly and continuously improve the performance of our products, processes, distribution and operating systems with respect to their impact on the health and safety of our employees and the public, as well as their impact on the environment.

It is particular concern to control or eliminate releases of those substances into the atmosphere which are known as ozone depleting substances (ODSs).

The Montreal Protocol (1987) and its London Amendments (1990) intend to severely restrict the use of ODSs and forbid their use within the next ten years. Various national and international initiatives are pressing for an earlier ban on these substances.

Vishay Semiconductor GmbH has been able to use its policy of continuous improvements to eliminate the use of ODSs listed in the following documents.

1. Annex A, B and list of transitional substances of the Montreal Protocol and the London Amendments respectively
2. Class I and II ozone depleting substances in the Clean Air Act Amendments of 1990 by the Environmental Protection Agency (EPA) in the USA
3. Council Decision 88/540/EEC and 91/690/EEC Annex A, B and C (transitional substances) respectively.

Vishay Semiconductor GmbH can certify that our semiconductors are not manufactured with ozone depleting substances and do not contain such substances.

We reserve the right to make changes to improve technical design and may do so without further notice.

Parameters can vary in different applications. All operating parameters must be validated for each customer application by the customer. Should the buyer use Vishay Semiconductors products for any unintended or unauthorized application, the buyer shall indemnify Vishay Semiconductors against all claims, costs, damages, and expenses, arising out of, directly or indirectly, any claim of personal damage, injury or death associated with such unintended or unauthorized use.

Vishay Semiconductor GmbH, P.O.B. 3535, D-74025 Heilbronn, Germany
Telephone: 49 (0) 7131 67 2831, Fax number: 49 (0) 7131 67 2423



Notice

Specifications of the products displayed herein are subject to change without notice. Vishay Intertechnology, Inc., or anyone on its behalf, assumes no responsibility or liability for any errors or inaccuracies.

Information contained herein is intended to provide a product description only. No license, express or implied, by estoppel or otherwise, to any intellectual property rights is granted by this document. Except as provided in Vishay's terms and conditions of sale for such products, Vishay assumes no liability whatsoever, and disclaims any express or implied warranty, relating to sale and/or use of Vishay products including liability or warranties relating to fitness for a particular purpose, merchantability, or infringement of any patent, copyright, or other intellectual property right.

The products shown herein are not designed for use in medical, life-saving, or life-sustaining applications. Customers using or selling these products for use in such applications do so at their own risk and agree to fully indemnify Vishay for any damages resulting from such improper use or sale.