



JM38510/13501/13502

ULTRA-LOW OFFSET VOLTAGE
OPERATIONAL AMPLIFIERS

Precision Monolithics Inc.

T-79-06-10

FEATURES

- Low V_{OS} $25\mu V$
- Low V_{OS} Drift $0.6\mu V/^\circ C$
- Low Noise $0.6\mu V_{p-p}$
- Wide Supply Voltage Range $\pm 4.5V$ to $\pm 20V$

have identical operational performance characteristics across the military temperature range or reliability factors equivalent to the MIL-M-38510 device.

ORDERING INFORMATION

| JAN SLASH SHEET | PMI DEVICE |
|------------------|----------------|
| JM38510/13501BGC | OP07AJ1/38510 |
| JM38510/13501BGA | OP07AJ5/38510 |
| JM38510/13501SGA | OP07SAJ5/38510 |
| JM38510/13501BPB | OP07AZ2/38510 |
| JM38510/13501BPA | OP07AZ5/38510 |
| JM38510/13501SPA | OP07SAZ5/38510 |
| JM38510/13502BGC | OP07J1/38510 |
| JM38510/13502BGA | OP07J5/38510 |
| JM38510/13502SGA | OP07SJ5/38510 |
| JM38510/13502BPB | OP07Z2/38510 |
| JM38510/13502BPA | OP07Z5/38510 |
| JM38510/13502SPA | OP07SZ5/38510 |

| MILITARY DEVICE TYPE | GENERIC-INDUSTRY TYPE |
|----------------------|-----------------------|
| 01 | OP07A |
| 02 | OP07 |

For an 833-processed device with improved electrical specifications, review the OP-07 data sheet.

PIN CONNECTIONS

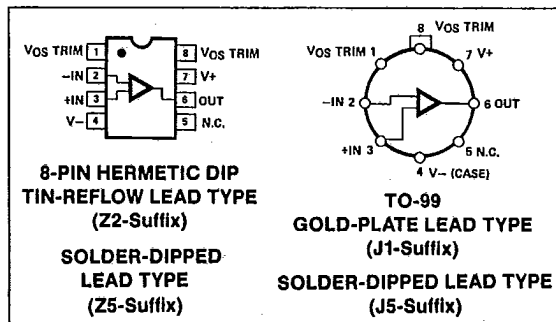

GENERAL DESCRIPTION

This data sheet covers the electrical requirements for a monolithic, low offset voltage, internally-compensated operational amplifier as specified in MIL-M-38510/135 for device type 01 and 02. Devices supplied to this data sheet are manufactured and tested at PMI's MIL-M-38510 certified facility and are listed in QPL-38510.

Complete device requirements will be found in MIL-M-38510 and MIL-M-38510/135 for Class B and Class S processed devices.

GENERIC CROSS-REFERENCE INFORMATION

This cross-reference information is presented for the convenience of the user. The generic-industry types listed may not

POWER AND THERMAL CHARACTERISTICS

| Case Outline | Package | Maximum Allowable Power Dissipation | Maximum θ_{JC} | Maximum θ_{JA} |
|--------------|--------------|-------------------------------------|-----------------------|-----------------------|
| P | Dual-In-Line | 208mW @ $T_A = 125^\circ C$ | 50°C/W | 120°C/W |
| G | 8-Lead CAN | 167mW @ $T_A = 125^\circ C$ | 40°C/W | 150°C/W |

SIMPLIFIED SCHEMATIC

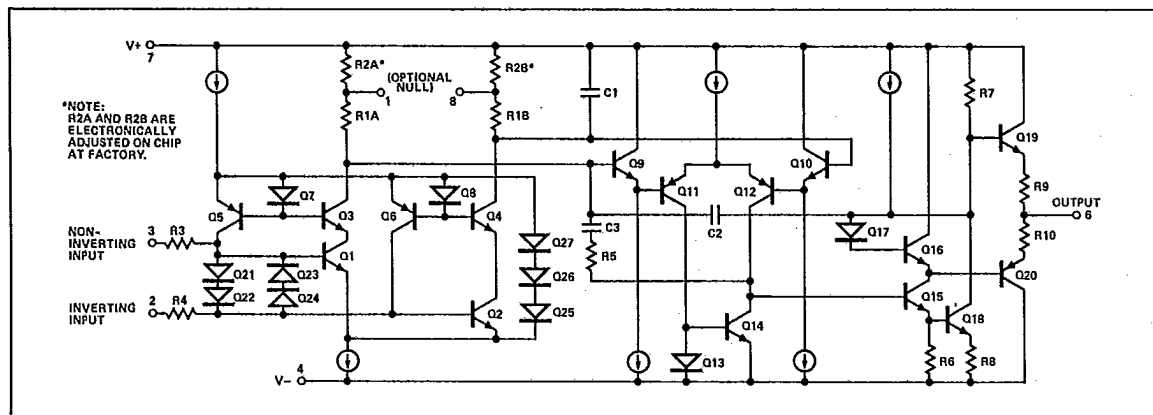



ABSOLUTE MAXIMUM RATINGS

| | |
|--|-----------------------------------|
| Supply Voltage (V_{CC}) | $\pm 22V$ |
| Input Voltage Range (V_{IN}) | $\pm V_{CC}$ |
| Differential Input Voltage Range | $\pm 30V$ |
| Output Short-Circuit Duration (Note 1) | |
| Lead Temperature (Soldering, 60 sec) | $+300^{\circ}C$ |
| Storage Temperature Range | $-65^{\circ}C$ to $+150^{\circ}C$ |
| Junction Temperature (T_J) | $+150^{\circ}C$ |
| Maximum Power Dissipation (P_D) (Note 2) | 500mW |

RECOMMENDED OPERATING CONDITIONS

| | |
|---------------------------|-----------------------------------|
| Supply Voltage Range | $\pm 4.5V$ to $\pm 20V$ |
| Ambient Temperature Range | $-55^{\circ}C$ to $+125^{\circ}C$ |

T-79-06-10

NOTES:

- Output may be shorted to ground indefinitely at $V_S = \pm 15V$, $T_A = 25^{\circ}C$. Temperature and/or supply voltages must be limited to ensure dissipation rating is not exceeded.
- Maximum power dissipation versus ambient temperature.

ELECTRICAL CHARACTERISTICS at $\pm 4.5V \leq V_{CC} \leq \pm 20V$ and $-55^{\circ}C \leq T_A \leq 125^{\circ}C$, $R_S = 50\Omega$ unnullled, unless otherwise noted.

| PARAMETER | SYMBOL | CONDITIONS | 01 LIMITS | | 02 LIMITS | | UNITS |
|--|--------------------------|--|-----------|-----|-----------|-----|-------------------|
| | | | MIN | MAX | MIN | MAX | |
| Input Offset Voltage | V_{IO} | $T_A = 25^{\circ}C$ (Notes 1, 2) | -25 | 25 | -75 | 75 | μV |
| | | | -60 | 60 | -200 | 200 | |
| Input Offset Voltage Temperature Sensitivity | $\Delta V_{IO}/\Delta T$ | (Note 1) | -0.6 | 0.6 | -1.3 | 1.3 | $\mu V/^{\circ}C$ |
| Input Bias Current | $+I_{IB}$ | $T_A = 25^{\circ}C$ (Note 1) | -2 | 2 | -3 | 3 | nA |
| | $-I_{IB}$ | $T_A = 25^{\circ}C$ (Note 1) | -4 | 4 | -6 | 6 | |
| Input Offset Current | I_{IO} | $T_A = 25^{\circ}C$ (Note 1) | -2 | 2 | -2.8 | 2.8 | nA |
| | | | -4 | 4 | -5.6 | 5.6 | |
| Power Supply Rejection Ratio | +PSRR | $+V_{CC} = 20V$ to $5V$, $-V_{CC} = -15V$ $T_A = 25^{\circ}C$ | — | 10 | — | 10 | $\mu V/V$ |
| | -PSRR | $+V_{CC} = 15V$, $-V_{CC} = -20V$ to $-5V$ $T_A = 25^{\circ}C$ | — | 10 | — | 10 | |
| | +PSRR | $+V_{CC} = 20V$ to $5V$, $-V_{CC} = -15V$ | — | 20 | — | 20 | |
| | -PSRR | $+V_{CC} = 15V$, $-V_{CC} = -20V$ to $-5V$ | — | 20 | — | 20 | |
| | PSRR | $V_{CC} = \pm 4.5V$ to $\pm 20V$ $T_A = 25^{\circ}C$ | — | 10 | — | 10 | |
| | | $V_{CC} = \pm 4.5V$ to $\pm 20V$ | — | 20 | — | 20 | |

NOTES:

- Tested at $V_{CM} = 0$, $V_{CC} = \pm 15V$.
- Due to the inherent warm-up drift, testing shall occur no sooner than three (3) minutes after application of power.

5

OPERATIONAL AMPLIFIERS/BUFFERS



ELECTRICAL CHARACTERISTICS at $\pm 4.5V \leq V_{CC} \leq \pm 20V$ and $-55^\circ C \leq T_A \leq +125^\circ C$, $R_S = 50\Omega$ unnull'd, unless otherwise noted. *Continued*

T-79-06-10

| PARAMETER | SYMBOL | CONDITIONS | 01 LIMITS | | U2 LIMITS | | UNITS |
|--|--------------------------|--|-----------|-----|-----------|-----|-----------------|
| | | | MIN | MAX | MIN | MAX | |
| Common-Mode Rejection Ratio | CMRR | $V_{CM} = \pm 13V, T_A = +25^\circ C, V_{CC} = \pm 15V$ | 110 | - | 110 | - | dB |
| | | $V_{CM} = \pm 13C, V_{CC} = \pm 15V$ | 106 | - | 106 | - | |
| Adjustment for Input Offset | $V_{IO} \text{ Adj (+)}$ | $T_A = +25^\circ C$ (Note 1) | 0.5 | - | 0.5 | - | mV |
| | $V_{IO} \text{ Adj (-)}$ | $T_A = +25^\circ C$ (Note 1) | - | 0.5 | - | 0.5 | |
| Output Short-Circuit Current | $I_{OS(+)}$ | $t \leq 25ms$ (Notes 1, 3) $T_A = +25^\circ C, +125^\circ C$ | -65 | - | -65 | - | mA |
| | | $T_A = -55^\circ C$ | -70 | - | -70 | - | |
| | $I_{OS(-)}$ | $t \leq 25ms$ (Notes 1, 3) $T_A = +25^\circ C, +125^\circ C$ | - | 65 | - | 65 | |
| | | $T_A = -55^\circ C$ | - | 70 | - | 70 | |
| Supply Current | I_{CC} | $T_A = +25^\circ C$ (Note 1) | - | 4 | - | 4 | mA |
| | | | - | 5 | - | 5 | |
| Output Voltage Swing (Minimum) | V_{OP} | $R_L = 1k\Omega$ (Note 1) | -10 | 10 | -10 | 10 | V |
| | | $R_L = 2k\Omega$ (Note 1) | -12 | 12 | -12 | 12 | |
| Open-Loop Voltage Gain (Single-Ended) | A_{VS} | $T_A = +25^\circ C$ (Notes 1, 2) | 300 | - | 200 | - | V/mV |
| | | | 200 | - | 150 | - | |
| Slew Rate | $SR(+), SR(-)$ | $V_{IN} = 10V, T_A = +25^\circ C$, (Note 1) | 0.08 | - | 0.08 | - | V/ μs |
| Input Noise Voltage Density | e_n | $f_O = 10Hz$ | - | 18 | - | 18 | nV/ \sqrt{Hz} |
| | | $f_O = 100Hz, T_A = +25^\circ C$ (Note 1) | - | 14 | - | 14 | |
| | | $f_O = 1kHz$ | - | 12 | - | 12 | |
| Low Frequency Input Noise Voltage | e_{np-p} | $f = 0.1Hz$ to $10Hz, T_A = 25^\circ C$, (Note 1) | - | 0.6 | - | 0.6 | μV_{p-p} |

NOTES:

1. Tested at $V_{CM} = 0, V_{CC} = \pm 15V$.
2. $V_{OUT} = 0$ to $+10V$ for $A_{VS(+)}$ and $V_{OUT} = 0$ to $-10V$ for $A_{VS(-)}$. $R_L = 2k\Omega$.
3. Continuous short-circuit limits are considerably less than the indicated test limits, since maximum power dissipation cannot be exceeded.