

*New*

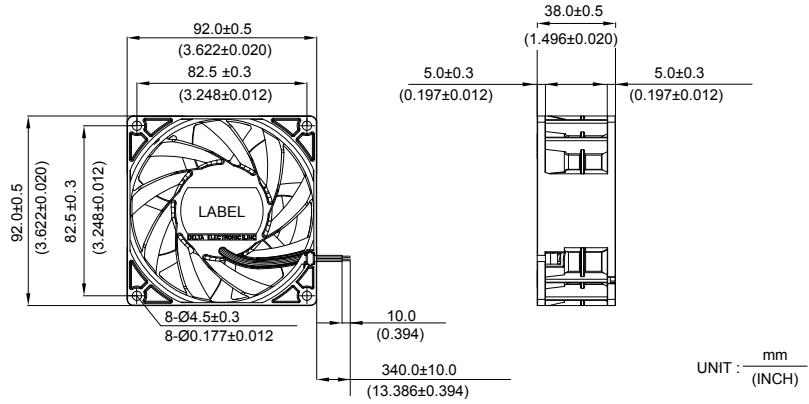

# THB 92 x 92 x 38 MM SERIES

## DIMENSIONS DRAWING



- \* Bearing Type  
Ball Bearings
- \* Material  
Impeller & Frame : Plastic (UL 94V-0)
- \* Lead Wires :  
UL 1061 AWG #24 OR Equivalent  
Red Wire Positive(+)  
Black Wire Negative(-)  
Blue Wire (F00)  
Yellow Wire Speed Control (PWM)
- \* Weight : 225g (7.933 oz)

## P & Q CURVE (AT RATED VOLTAGE)

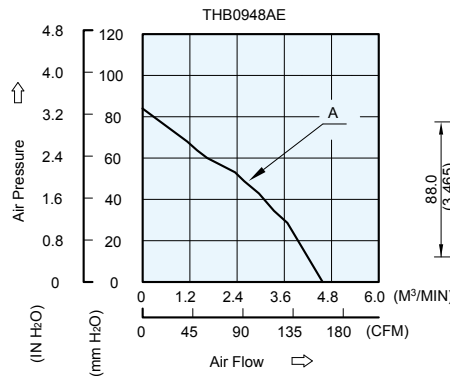

## MOUNTING PANEL CUTOUT

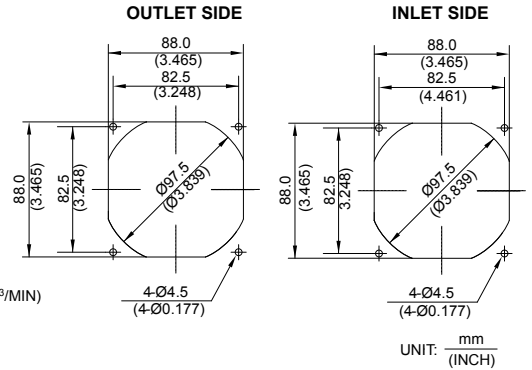

MODEL		Rated Voltage	Operating Voltage Range	Input Current	Input Power	Speed	Maximum Air Flow		Maximum Air Pressure		Noise
PART NO.	FUNCTION	VDC	VDC	Amp	Watt	R.P.M.	m <sup>3</sup> /min	CFM	mmH <sub>2</sub> O	IN H <sub>2</sub> O	dB-A
THB0948AE	PWM/-F00	48	36.0 to 60.0	0.76	36.50	13000	4.602	162.50	78.46	3.089	72.5

- \* Function type is optional.
- \* The max. air flow and the speed are measured in free air ; max. air pressure is measured at zero air flow.
- \* Noise is measured in anechoic chamber in free air, one meter from intake side.
- \* All readings are typical values at rated voltage.
- \* Specifications are subject to change without notice.