

SMD Inductors(Coils) For Power Line(Multilayer, Magnetic Shielded)

Conformity to RoHS Directive

MLP Series MLP2016

With its internal structure optimized, the MLP2016 type has achieved DC superimposition characteristics that are comparable to those of the existing MLP2520 type.

In addition, because low-loss materials are used, the core loss of the coil can be minimized within a wide frequency range.

MLP2016's choke coils are therefore best suited to several MHz-drive switching power supplies, the use of which is especially prominent in mobile devices.

FEATURES

- MLP2016 has DC super imposition characteristics that are comparable to that of the existing MLP2520 type.
- Optimized ferrite materials enable the reduction of losses.
- Magnetically shielded configuration allowing for high-density mounting.
- The products contain no lead and also support lead-free soldering.
- It is a product conforming to RoHS directive.

APPLICATIONS

Cellular phones, DSCs, DVCs, HDDs, etc.

SPECIFICATIONS

Operating temperature range	-40 to +125°C [Including self-temperature rise]
Storage temperature range	-40 to +85°C

RECOMMENDED SOLDERING CONDITION REFLOW SOLDERING

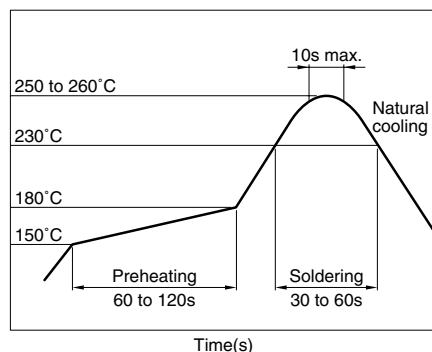

PRODUCT IDENTIFICATION

MLP	2016	S	2R2	M	T
(1)	(2)	(3)	(4)	(5)	(6)

(1) Series name

(2) Dimensions L×W

2016	2.0×1.6mm
------	-----------

(3) Product characteristics classification code

S	STD
---	-----

(4) Inductance value

2R2	2.2μH
-----	-------

(5) Management number

M	t=0.85mm
---	----------

(6) Packaging style

T	Taping [reel]
---	---------------

PACKAGING STYLE AND QUANTITIES

Packaging style	Quantity
Taping	3000 pieces/reel

HANDLING AND PRECAUTIONS

- Before soldering, be sure to preheat components. The preheating temperature should be set so that the temperature difference between the solder temperature and product temperature does not exceed 150°C.
- After mounting components onto the printed circuit board, do not apply stress through board bending or mishandling.
- The inductance value may change due to magnetic saturation if the current exceeds the rated maximum.
- Do not expose the inductors to stray magnetic fields.
- Avoid static electricity discharge during handling.
- When hand soldering, apply the soldering iron to the printed circuit board only. Temperature of the iron tip should not exceed 350°C. Soldering time should not exceed 3 seconds.

• Conformity to RoHS Directive: This means that, in conformity with EU Directive 2002/95/EC, lead, cadmium, mercury, hexavalent chromium, and specific bromine-based flame retardants, PBB and PBDE, have not been used, except for exempted applications.

• Please contact our Sales office when your application are considered the following:
The device's failure or malfunction may directly endanger human life (e.g. application for automobile/aircraft/medical/nuclear power devices, etc.)

• All specifications are subject to change without notice.

SHAPES AND DIMENSIONS/RECOMMENDED PC BOARD PATTERN

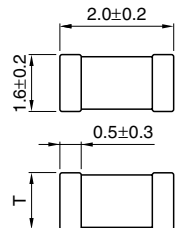

T	Weight(mg)
0.85±0.15	12



Dimensions in mm

ELECTRICAL CHARACTERISTICS

Classification	Part No.	Inductance (μH)	Inductance tolerance	Test frequency (MHz)	DC resistance (Ω)±30%	Rated current (mA)	Thickness (mm)max.
STD	MLP2016SR47MT	0.47	±20%	2	0.05	1600	1
	MLP2016S1R0MT	1.0	±20%	2	0.09	1400	1
	MLP2016S1R5MT	1.5	±20%	2	0.09	1200	1
	MLP2016S2R2MT	2.2	±20%	2	0.11	1200	1
	MLP2016S4R7MT	4.7	±20%	2	0.27	800	1

TYPICAL ELECTRICAL CHARACTERISTICS

INDUCTANCE vs. FREQUENCY CHARACTERISTICS

T=1.0mm max.

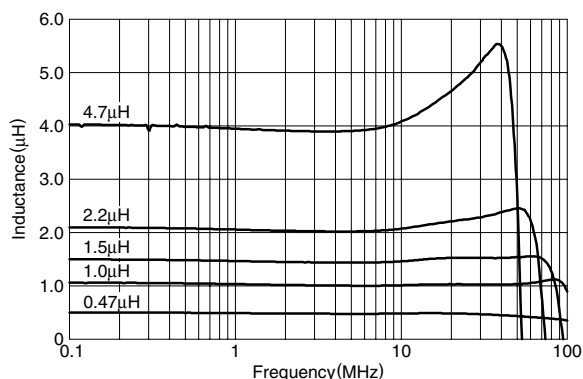

INDUCTANCE CHANGE vs. DC SUPERPOSITION CHARACTERISTICS

T=1.0mm max.

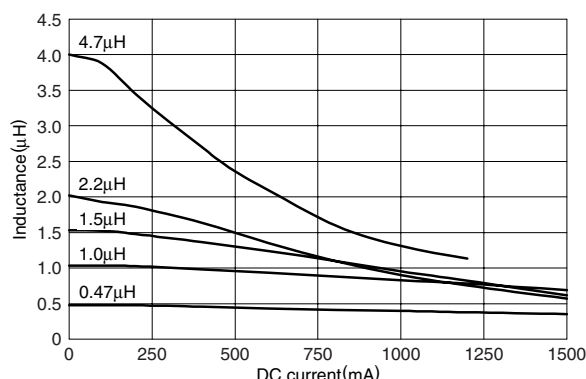

PACKAGING STYLES

REEL DIMENSIONS

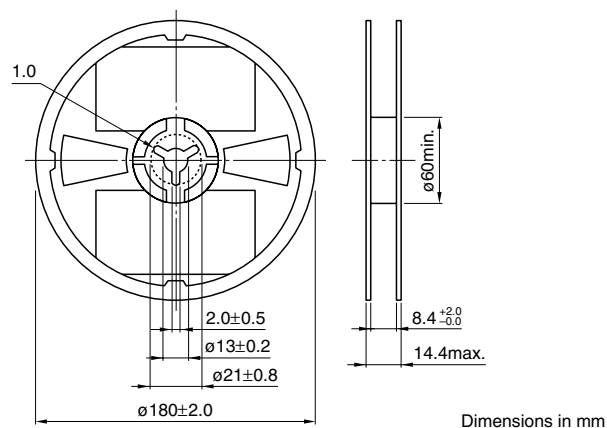

Dimensions in mm

TAPE DIMENSIONS

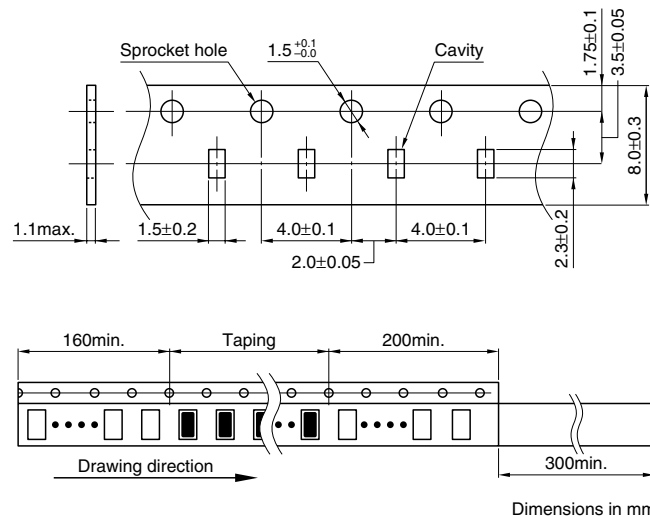

Dimensions in mm

• All specifications are subject to change without notice.