

Single-phase energy meter based on the STPM metering IC and STM8L152C6 MCU

Introduction

This document describes the functions of the single-phase energy meter based on the STPM metering IC and an STM8L152C6 microcontroller. The demonstration board is a fully functional single-phase solution with parameter display, tamper management, maximum demand (MD) calculation, EEPROM data logging, and low power management.

Meter specifications:

- Accuracy: 1 % error with dynamic range 200:1
- Nominal voltage: 240 V
- Nominal current: 5 A (I_{TYP})
- Maximum current: 45 A (I_{MAX})
- Operating range: 0.6 Vb to 1.2 Vb
- Meter constant: 3200 impulses/kWh
- Power frequency range: 45 Hz to 65 Hz
- Sensor: primary side CT and secondary side shunt
- Communication interface: IrDA[®].

Figure 1. Single-phase energy meter solution based on STPM and STM8L

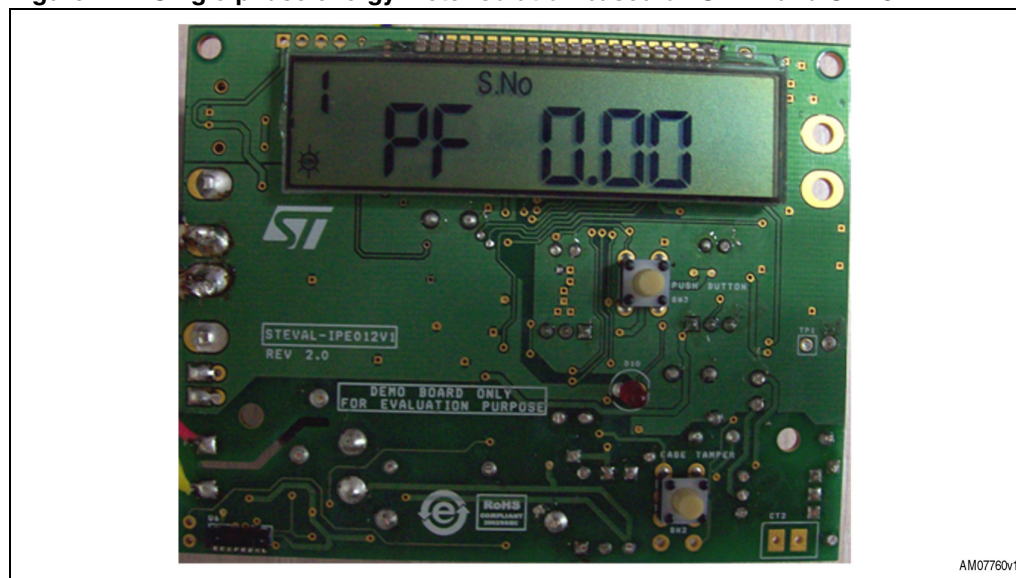

Contents

1	Features	5
2	Overview	6
2.1	Safety rules	6
2.2	Recommended reading	6
2.3	Getting technical support	6
3	Getting started	7
3.1	Package	7
3.2	Hardware installation	7
3.3	Software installation	8
3.3.1	System requirements for demonstration GUI	8
4	Hardware layout	9
5	Hardware details	10
5.1	Metering IC U1	10
5.1.1	Clocking Y1	10
5.2	Microcontroller U2	10
5.2.1	LED D10	10
5.2.2	Switch SW1 and SW2	10
5.2.3	Jumper J2	10
5.2.4	Clocking Y2	10
5.3	Power supply section	11
5.3.1	Programmable voltage reference U5	11
5.3.2	Current sensor CT1	11
5.3.3	Shunt RS1	11
5.4	Neutral missing power supply section	11
5.4.1	Current sensor CT2	11
5.5	EEPROM U3 section	11
5.6	LCD section	11
5.7	Battery management section	12
5.7.1	Coin cell BT1	12

5.7.2	Rechargeable battery BT2	12
5.7.3	Small signal Schottky diode D11, D12, D13, D14, D5	12
5.7.4	Switch SW3	12
5.8	IrDA section	12
5.8.1	IRDA transceiver U6	12
5.8.2	Jumper J6	12
5.9	Magnetic sensor U4	13
5.10	Connector section	13
6	Single-phase energy meter features	14
6.1	Auto-calibration mode	14
6.1.1	Steps for auto-calibration	14
6.2	EEPROM data log	15
6.3	Power management	15
6.3.1	Meter run mode	15
6.3.2	Meter low power mode	15
6.4	LCD display modes	16
6.4.1	Meter run mode display	16
6.4.2	Meter low power mode display	17
6.5	Tamper detection	17
6.5.1	Tamper types	17
6.5.2	LCD symbol for tamper condition	17
6.6	62056-21 IrDA protocol mode C	18
6.6.1	IrDA modes	18
6.6.2	SerialIO GUI	18
6.7	Pulse out LED	19
7	EEPROM log data structure	20
7.1	Size overview	21
7.2	Entry structure	21
	Appendix A Tamper definitions	23
	Appendix B BOM list and schematics	24
8	Revision history	33

List of figures

Figure 1.	Single-phase energy meter solution based on STPM and STM8L.....	1
Figure 2.	Electricity meter connection diagram	7
Figure 3.	Hardware layout: top view	9
Figure 4.	Hardware layout: bottom view	9
Figure 5.	Auto-calibration mode connection diagram	14
Figure 6.	SerialIO GUI hardware setup	19
Figure 7.	SerialIO GUI with protocol mode C settings	19
Figure 8.	Microcontroller schematic	29
Figure 9.	Battery, connector, magnetic sensor and IrDA module schematics	30
Figure 10.	Power supply, EEPROM, LCD and neutral missing power supply schematics	31
Figure 11.	STPM schematic.....	32

1 Features

The single-phase energy meter has the following features:

- Low cost single-phase energy meter solution
- Supports IEC 61036:1996 + A1: 2000, static meter for active energy class 1 for $I_b=5$ A
- Less than 4 VA power consumption for voltage circuit at reference voltage
- Less than 1 VA power consumption for current circuit at reference basic current
- Multiple tamper detection: earth, neutral missing, reverse, case tamper, magnetic tamper detection
- Case tamper detection also in power-down
- Detects signals and continues to measure accurately under tamper condition
- Rechargeable battery is available on the board for showing LCD parameters in case of power-down mode
- Active energy pulse output 3200 impulses/kWh
- Software based auto-calibration without the need of a reference meter, only the reference source is required
- Microcontroller in-built RTC for date and time display
- Microcontroller STM8L152C6 is responsible for all data management, display and power management
- STPM metering IC with 1st order sigma-delta ADC for energy measurements
- Single point and fast calibration of STPM for class 1 meter
- External EEPROM used to store calibration parameters, tampering information, cumulative energy, MD and power factor (PF) data
- Active power, current, voltage, power factor and line frequency measurements
- Numeric display precision (except cumulative energy): 5+2 digits
- Numeric display precision for cumulative energy: 5+1 digits
- Energy EEPROM log precision: 0.01 kWh.

2 Overview

2.1 Safety rules

This board can be connected to mains voltage (240 V). In the case of improper use, wrong installation or malfunction, there is a danger of serious personal injury and damage to property. All operations such as transport, installation and commissioning, as well as maintenance, should be carried out only by skilled technical personnel (regional accident prevention rules must be observed).

Warning: Due to the risk of death when using this prototype on mains voltage (240 V), only skilled technical personnel who are familiar with the installation, mounting, commissioning and operation of power electronic systems and have the qualifications needed to perform these functions, may use this prototype.

2.2 Recommended reading

This document describes how to use the multi-tariff meter demonstration board. Additional information can be found in the following documents:

- STPM01; *Programmable single-phase energy metering IC with tamper detection*, datasheet
- STM8L152C6; *STM8L-Ultra Low Power-8 bits Microcontrollers*, datasheet
- Component datasheets
- IEC 62056-21 IrDA protocol mode C

2.3 Getting technical support

For technical assistance, documentation, information and updates for products and services, please refer to your local ST distributor/office.

3 Getting started

3.1 Package

The demonstration kit package includes the following items:

- Hardware content
 - STEVAL-IPE012V1 demonstration board
- Software
 - SerialIO GUI for IrDA communication testing
- Documentation
 - User manual
 - Presentation
 - Schematic
 - BOM list

3.2 Hardware installation

Connect the STEVAL-IPE012V1 demonstration board with the mains supply before load. Please refer to [Figure 2](#) for connection with mains power and load.

Auto-scrolling LCD display indicates successful power-up of board.

Figure 2. Electricity meter connection diagram

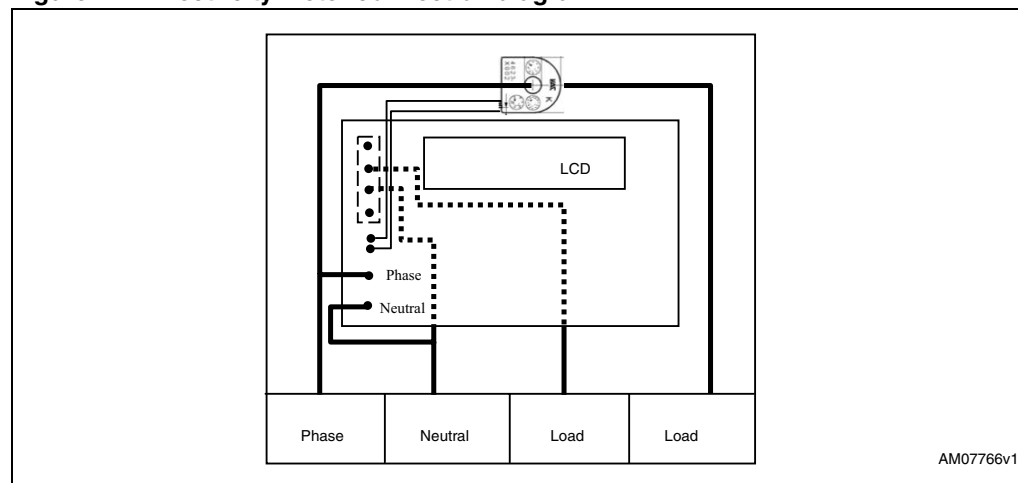

3.3 Software installation

The demonstration kit supports the SerialIO GUI for RS232 testing to check 62056-21 IrDA protocol mode C implementation.

3.3.1 System requirements for demonstration GUI

For demonstration board communication with the GUI, a recent version of Windows, Windows XP must be installed on the PC. The SerialIO GUI does not require any driver installation.

Note: Windows is a registered trademark of the Microsoft Corporation in the United States and other countries.

The version of the Windows OS installed on the PC can be determined by clicking on the system icon in the control panel.

4 Hardware layout

The demonstration kit hardware is designed in a sectional approach to offer multiple functions to users.

Figure 3. Hardware layout: top view

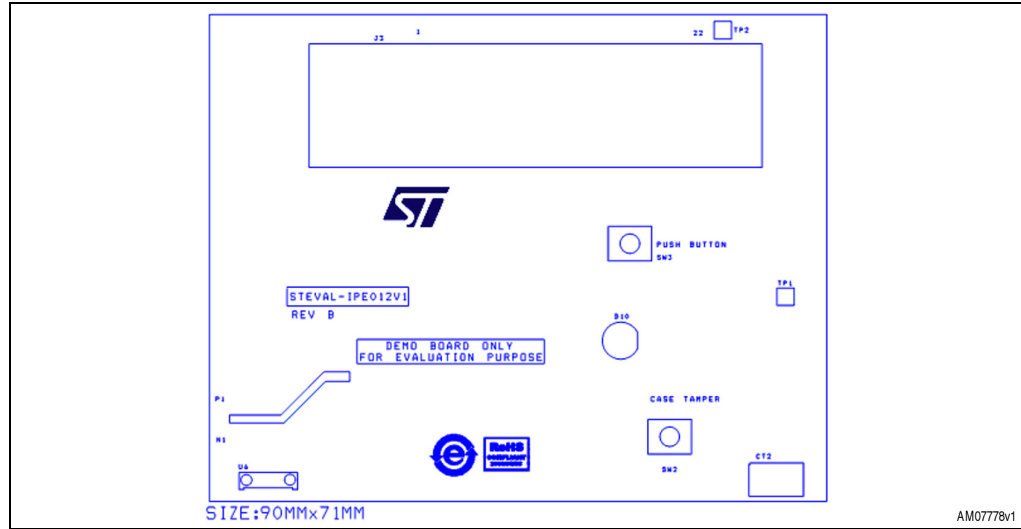
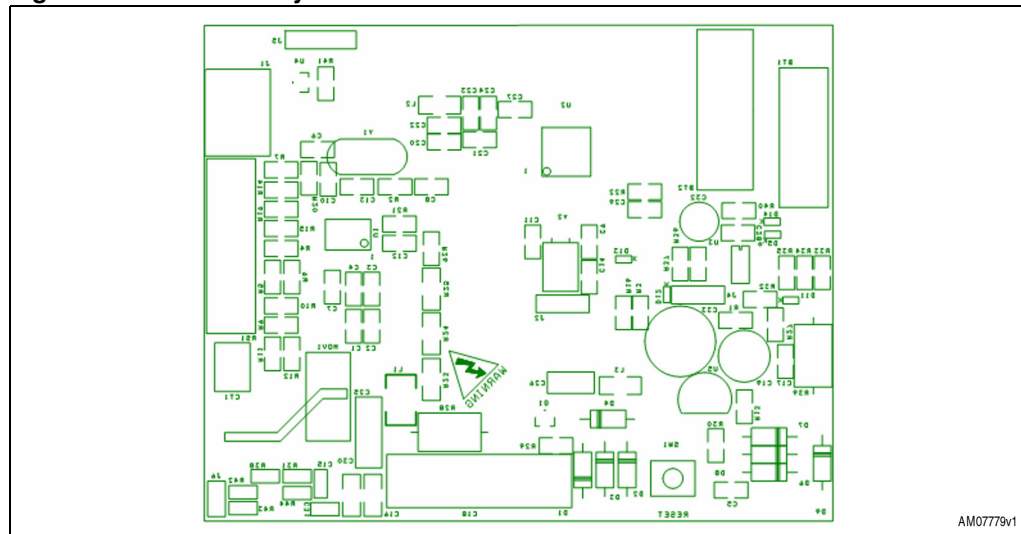

Figure 4. Hardware layout: bottom view



5 Hardware details

5.1 Metering IC U1

The programmable single-phase energy metering IC STPM01BTR (package: TSSOP20) is interfaced to a microcontroller using a 3-wire SPI interface. Active energy, apparent energy, instantaneous voltage, and instantaneous current values are obtained from the STPM metering IC. Auto-calibration is implemented to calibrate the STPM.

5.1.1 Clocking Y1

A 4.194 MHz crystal is used as the clock generator input for the metering IC. For more details about auto-calibration, please refer to [Section 6.1: Auto-calibration mode](#).

5.2 Microcontroller U2

The microcontroller STM8L152C6 (package: LQFP48, 32K Flash, 2KB RAM, 48-pin) is responsible for all the data management and power management tasks. MCU consumes very lower power and has an in-built RTC for date and time management.

5.2.1 LED D10

LED D10 is the pulse out LED for cumulative energy. This is used for testing the energy meter energy calculation accuracy.

5.2.2 Switch SW1 and SW2

Switch SW1 is the reset switch for the microcontroller. Switch SW2 is the case tamper switch which is used to detect case tampering of energy meter solution.

For more details, refer to [Section 6.4: LCD display modes](#).

5.2.3 Jumper J2

Table 1. 3-pin jumper header

Jumper	Close: 1-2	Close: 2-3	Default
J2	Microcontroller pin PA1 is connected to reset switch SW1	Microcontroller pin PA1 is connected to LED D10	Close: 2-3

5.2.4 Clocking Y2

A 32.768 kHz crystal is used as the clock input for LSE (low speed external) for the microcontroller RTC block. The microcontroller core is clocked by a HSI (high speed internal) clock.

5.3 Power supply section

Capacitive power supply is used to build 3.6 V for the metering IC and microcontroller section.

5.3.1 Programmable voltage reference U5

A U5 TL431AI (package TO-92) is used to regulate the 3.6 V supply.

5.3.2 Current sensor CT1

CT1 E4623-X002 (2500 turns, series resistance: 61.5 Ω) is the sensor for the primary current channel.

5.3.3 Shunt RS1

RS1 500uOHM is the sensor for the secondary current channel.

5.4 Neutral missing power supply section

The neutral missing power supply section is operational in the case of neutral missing tamper. In case of a neutral missing tamper condition, neutral is disconnected from the energy meter. Therefore, there is no voltage input and so no output would be generated by the main capacitive power supply. However, in the case of load present, there would be a valid input signal on the current channel so energy would be consumed. As the voltage on the neutral channel is zero, so is the power ($P = V \times I$). In order to understand the energy consumed in this case, the neutral missing power supply section provides the voltage supply to the STPM metering IC. A zero crossing signal of 50 Hz is provided to the VIP pin of STPM, so STPM now calculates the energy consumption at a nominal voltage level of 240 V.

5.4.1 Current sensor CT2

CT2 is used to develop the power supply for the board using a diode full wave rectifier circuit in neutral missing condition.

5.5 EEPROM U3 section

EEPROM M24C32-RMN6P (package: SO8, 32 Kbit) is interfaced to the microcontroller using an I²C bus. Cumulative energy, MD, average PF and tamper information for seven consecutive months is logged as months in EEPROM. For more details about EEPROM data logging, refer to [Section 6.2: EEPROM data log](#).

5.6 LCD section

LCD J3 is the connector for the external 18* 4 LCD glass. LCD glass OPT6089A (operating voltage 3 V, duty 1/4, bias 1/3) offers various energy meter specific symbols. LCD glass is driven by the microcontroller internal LCD driver.

5.7 Battery management section

Two batteries are used in the circuit.

5.7.1 Coin cell BT1

BT1 CR2032 (3 V, 225 mAh) is the microcontroller power source in halt mode to keep RTC running.

5.7.2 Rechargeable battery BT2

BT2 VL2330 (3 V, 50 mAh) is for push button and IrDA operation when mains power is off.

- rechargeable battery acts as power source for microcontroller section when push button is pressed during mains power off
- rechargeable battery is charged based on trickle charging mode during mains power on.

5.7.3 Small signal Schottky diode D11, D12, D13, D14, D5

Diodes (D11, D12, D13, D14, and D5) BAT30KFILM (SOD - 523) based circuit is used to select the power source for the microcontroller.

5.7.4 Switch SW3

Switch SW3 is the push button switch which is used to control the LCD display modes.

When mains power is on, once the push button is pressed, the LCD display is executed as per the push button run mode.

When mains power is off, once the push button is pressed, the LCD display is executed as per the push button low power mode.

5.8 IrDA section

5.8.1 IRDA transceiver U6

The IrDA transceiver TFDU4300 is used for IrDA communication.

5.8.2 Jumper J6

Using jumper J6, IrDA transmit and receive pins allow testing of the IrDA section using the SerialIO GUI.

For more details, please refer to [Section 6.6.2: SerialIO GUI](#).

Table 2. Pin jumper headers

Jumper	Pin1	Pin 2
J6	PC3_IRDA_Tx IRDA transmit pin	PC2_IRDA_Rx IRDA receive pin

5.9 Magnetic sensor U4

The magnetic sensor AH180 (SC59-3L) is used to detect magnetic interference in the energy meter solution. Magnetic sensor outputs low when magnetic interference occurs.

5.10 Connector section

The connector section comprises test points for different signals.

Table 3. 4-pin jumper headers

Jumper	Pin1	Pin2	Pin3	Pin4
J1	VDD	PA0_SWIM SWIM interface data pin	GND	PA1_NRST_PULSE_LED LED pulse output/reset signal
J5	PA0_SWIM SWIM interface data pin	PE6 GPIO	GND	PE7_STPM_ZCR metering IC ZCR signal

Table 4. 3-pin jumper header

Jumper	Pin1	Pin 2	Pin3
J6	PC0_EEPROM_SDA I ² C data signal	PC1_EEPROM_SCL I ² C clock signal	GND

6 Single-phase energy meter features

6.1 Auto-calibration mode

The STEVAL0-IPE012V1 demonstration board supports auto-calibration using an ideal reference source for 10 A and 240 V. Calibration is performed to minimize measurement errors and to increase the accuracy of the meter.

When using auto-calibration mode, calibration parameters CHV (one byte calibration data for voltage channel), CHP (one byte calibration data for primary current channel), and CHS (one byte calibration data for secondary current channel), are calculated and programmed in registers of the metering IC. The procedure for meter calibration is explained below by firstly giving an overview of the hardware setup, and then by describing how to connect a calibration board.

6.1.1 Steps for auto-calibration

- Connect 240 V voltage source to phase and neutral of board
- Connect 10 A source to board
- Push button SW3 for more than 4 sec
- Board enters auto-calibration mode; "CALIB ON" is displayed on the board
- Once calibration is complete, the board returns to auto-scroll display mode.

Figure 5. Auto-calibration mode connection diagram

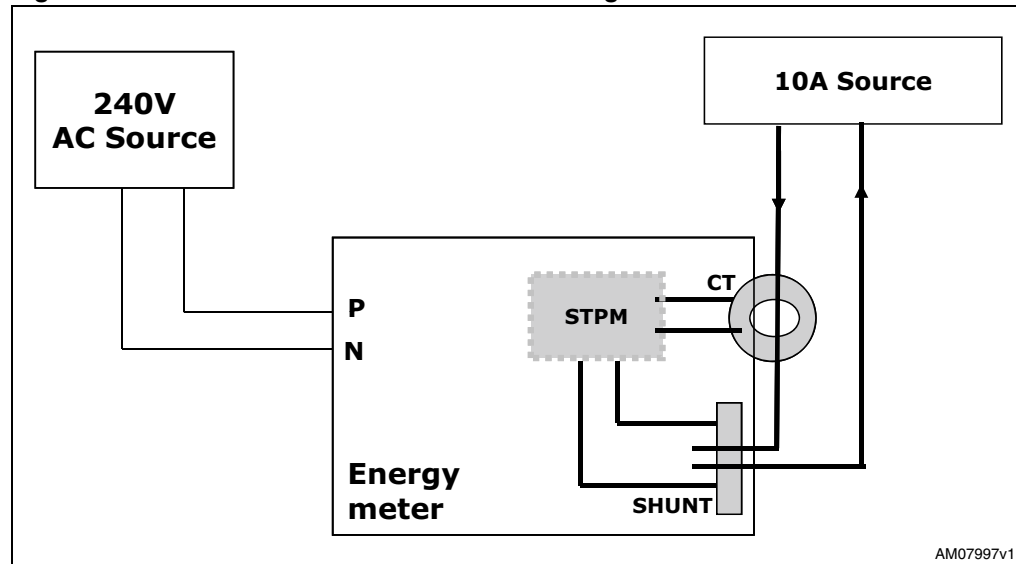

For more details of calibration parameters, refer to the STPM01 datasheet.

6.2 EEPROM data log

Total EEPROM data log size: 920 bytes.

Multiple parameters are stored in EEPROM, as below:

- The following metering parameters are logged in EEPROM memory for the current month and last six months
 - Cumulative energy (CE) until last month
 - Maximum demand (MD)
 - Cumulative energy (CE) consumed in current month
 - Average PF and averaging count
 - Tamper entries; four types of tamper data storage is done: earth, reverse, neutral, and case tamper. For each type of tamper, the number of tamper entries per month is four.
- Two duplicate entries of cumulative energy are stored with CRC-8 value for error detection
- 10 bytes stored for calibration data at start of EEPROM including 3 bytes of CHV, CHP, and CHS
- Last power-down date and time log
- Overflow count for cumulative energy
 - Number of times cumulative energy overflows from 99999.9 (maximum display precision).

For further details, refer to [Section 7](#).

6.3 Power management

The STEVAL-IPE012V1 demonstration board is designed with board power consumption 4 VA.

The board supports two modes of operation:

1. Meter run
2. Meter low power

6.3.1 Meter run mode

When mains power is on, the board operates in run mode. The board components are powered using a capacitive supply with main power line as the source. In this mode, the rechargeable battery is in charging mode based on the trickle charging technique.

6.3.2 Meter low power mode

When mains power goes down, the onboard microcontroller enters halt mode and metering IC is off. In this mode, the microcontroller RTC is running and low, other peripherals are off. In halt mode, the microcontroller is powered using BT1.

Therefore, push button SW3 is pressed in low power mode; BT2 supply connects to the supply input of the microcontroller and IrDA section, and so, in button pressed condition, BT2 is the main supply source.

Now the meter low power LCD display and IrDA communication are operational until push button SW3 is operational.

6.4 LCD display modes

The STEVAL-IPE012V1 demonstration board offers the user different parameters. The metering parameters display is configured in a specific manner based upon the power mode of the meter:

- Meter run mode LCD display
- Meter low power LCD display

6.4.1 Meter run mode display

During the main power-on condition, all the critical parameters, with details of last month's logs for metering parameters, are available on the display.

Parameter display is classified for mains on condition:

- Auto-scroll mode
- Push button display mode

Auto-scroll mode

In auto-scroll mode, the following parameters are displayed on the LCD one by one:

- Cumulative active energy (kWh)
- Max demand (kW) of last month
- Average PF of last consumption month

Note: Auto-scroll mode interval (8sec) is configurable in "autoscroll_display.h" in the firmware.

Push button mode

In push button mode, the parameters listed below are displayed on the LCD on pressing push button SW3. Each button push displays the next push button parameter. If the push button is in pressed condition for 4 seconds, the board enters auto-calibration mode. For more details on auto-calibration, please refer to [Section 6.1](#).

In push button mode, the following parameters are displayed on the LCD:

- All LCD segments on
- Date and time
- Max demand since last reset
- Cumulative energy for last six months
- Max demand for last six months
- Instantaneous PF
- Instantaneous voltage
- Instantaneous current
- Instantaneous load in Watts.

When the push button SW3 is released, the LCD display returns to auto-scroll mode after a push button mode interval (10 sec).

Note: Push button mode interval (8 sec) is configurable in "pushbutton_display.h" in the firmware.

6.4.2 Meter low power mode display

In low power mode, the display is off until push button SW3 is pressed. When push button SW3 is pressed in low power mode, the display is on in auto-scroll display mode. The display is active until push button SW3 is in a pressed condition.

6.5 Tamper detection

The STEVAL-IPE012V1 demonstration board supports multiple tamper detection and their logging in EEPROM.

6.5.1 Tamper types

The five types of tamper detection are:

1. Earth tamper
2. Reverse tamper
3. Neutral missing tamper
4. Case tamper
5. Magnetic interference

6.5.2 LCD symbol for tamper condition

- Earth tamper: Earth
- Reverse tamper: Rev
- Neutral missing tamper: 
- Case tamper: BP
- Magnetic interference: BP

Three tampers (earth, reverse and neutral missing) are detected using a software algorithm based on meter readings from the metering IC.

In the case of neutral missing tamper detection, the board starts recording energy when the load current is 2 A or higher.

Case tamper is detected using switch SW2 and magnetic interference is detected using magnetic sensor U4. Symbol 'BP' is shared for displaying case tamper as well as magnetic interference. It means if any of the tampers are detected, symbol 'BP' is displayed on the LCD.

For tamper definitions, refer to [Appendix A](#).

Note: In the present solution, magnetic tamper is not logged in EEPROM. Logging can be easily done by modifying the EEPROM log structure.

6.6 62056-21 IrDA protocol mode C

The STEVAL-IPE012V1 demonstration board supports 62056-21 IrDA protocol mode C. IrDA is used as the communication channel for reading meter data. In such systems, a handheld unit (HHU) or a unit with equivalent functions is connected to a tariff device (energy meter). The protocol offers five alternative protocol modes, A, B, C, D and E. This user manual covers mode C use. In mode C, data exchange is bi-directional and is always initiated by the HHU with the transmission of a request message. In this mode, the HHU acts as a master and the tariff device acts as a slave. These protocol modes permit meter reading, manufacturer specific operation and programming mode. It is designed to be highly suitable for electricity metering environments, particularly with regards to electrical isolation and data security.

6.6.1 IrDA modes

- Data read out mode
In data read out mode, the tariff device responds with all the data logged in EEPROM as per EEPROM data structure (refer to [Section 7](#)). Each data block consists of a sequence of data lines separated by carriage return (CR) and line feed (LF).
- Manufacturer specific mode
In manufacturer specific mode, RTC date and time setting is done
- Programming mode
In programming mode, as per the protocol, data read and write can be done at different locations of EEPROM.

6.6.2 SerialIO GUI

The SerialIO GUI can be used as the test GUI for 62056-21 IrDA protocol mode C implementation. Here, the protocol is tested using serial communication. For this testing, a daughter board with an RS232 converter is required to map PC serial data signals to 3.4 V data signals of the board.

Steps for serial communication based protocol testing:

1. Demount R41 and R42 from board
2. Comment “#defines IRDA_MODE_ENABLE” in “emter_irda.h”
3. Connect the RS232 daughter board as shown in [Figure 6](#)
4. Write data into the SerialIO GUI data box and send.

Figure 6. SerialIO GUI hardware setup

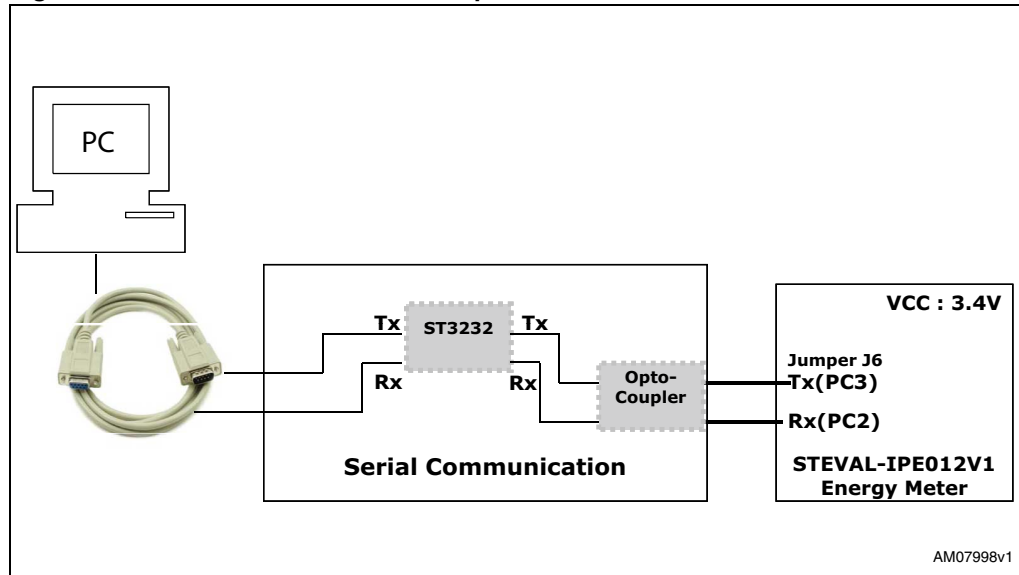
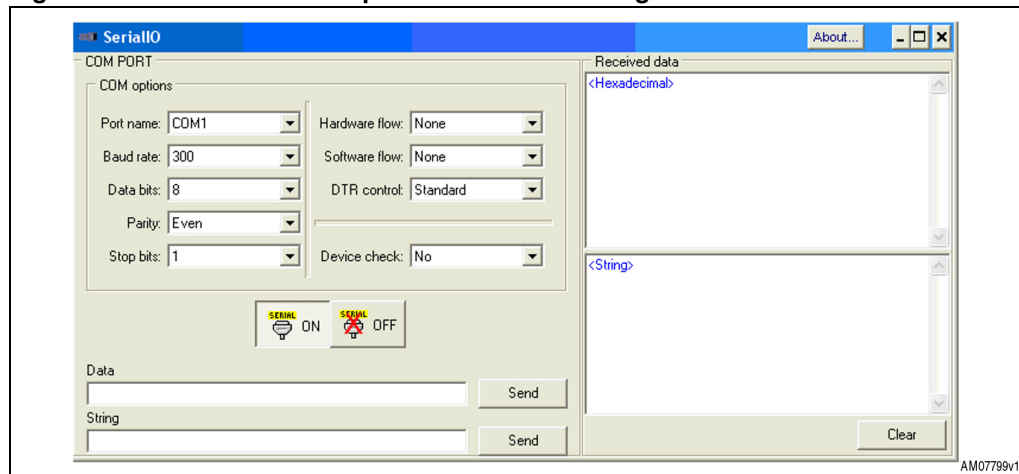

Figure 7. SerialIO GUI with protocol mode C settings



6.7 Pulse out LED

LED D10 is used as the pulse out for cumulative energy. It works on a meter constant of 3200impulses/kWh.

The LED output can be used to test the accuracy of the meter.

7 EEPROM log data structure

All the parameters below are stored in EEPROM:

- Calibration data (10 bytes): (3 bytes of CHV, CHP, and CHS then 7 times 0x00)
- Total cumulative energy: (at two locations - to keep duplicate entries)
- Total cumulative until last month: (monthly for last six months and current month)
- Maximum demand: (monthly for last six months and current month)
- Cumulative energy: (monthly for last six months and current month)
- Average PF and averaging count: (monthly for last six months and current month)
- Tamper information - earth, reverse, neutral missing, case tamper: (monthly for last six months and current month and four entries per month with count for tamper and date and time details)
- Count of cumulative energy overflow: count of cumulative energy overflow
- Date and time of last power-down; total size required: 920 bytes.

The data storage structure in EEPROM is as follows:

- Calibration data (CHV, CHP, CHS)
- CE main entry with CRC
- N month: CE until last month: MD: CE current month: average PF: tamper
- N-1 month: CE until last month: MD: CE current month: average PF: tamper
- N-2 month: CE until last month: MD: CE current month: average PF: tamper
- N-3 month: CE until last month: MD: CE current month: average PF: tamper
- N-4 month: CE until last month: MD: CE current month: average PF: tamper
- N-5 month: CE until last month: MD: CE current month: average PF: tamper
- N-6 month: CE until last month: MD: CE current month: average PF: tamper
- CE duplicate copy with CRC
- Count for cumulative energy overflow
- Power-down date and time.

Where N is the current month:

- All parameters are logged for a total of 7 months including one current and the last 6 months
- In the current month log, data is updated at day end and on power-down
- Total cumulative energy log is updated half-hourly
- Month serial order is updated at 2400 hours on the last date of each calendar month.

7.1 Size overview

Table 5. EEPROM parameter size overview

Parameter	Size (in byte)
Calibration data	10 (3 bytes (CHV, CHP, CHS) + 7 dummy bytes for future use)
Total cumulative energy duplicate entry 1	7 (4 bytes + 2 bytes + 1 byte (CRC))
Cumulative energy until last month	42 (7*6): without CRC
Maximum demand log	63 (7*(3+3+3))
Monthly cumulative energy log	42 (7*6)
Average PF log	42 (7*4 + 7*2)
Earth tamper log	175 (7*((4*(3+3)) + 1))
Reverse log	175 (7*((4*(3+3))+1))
Neutral missing log	175 (7*((4*(3+3)) + 1))
Case tamper log	175 (7*((4*(3+3))+1))
Total cumulative energy duplicate entry 2	7(4 bytes + 2 bytes + 1 byte (CRC))
Count for CE overflow	1 byte
Power-down entry	6 bytes

Note: EEPROM data structuring is done in a modular way in order to support future updates. Reconfigure parameters in header file "emeter_datamgmt.h", to modify the log structure entry count.

7.2 Entry structure

- Calibration data log
CHV, CHP, and CHS are calibration parameters for the current and voltage channel for the metering IC.

Table 6. Calibration data

Calibration data	Start address	Size
(CHV, CHP, CHS, 7 times 0x00)	0x00	10

For more details on calibration parameters, refer to the STPM01; *Programmable single-phase energy metering IC with tamper detection*, datasheet.

- Total cumulative energy log
 - Two duplicate entries are stored. One at the start of EEPROM and another at the end of EEPROM
 - This is done to make sure that, if EEPROM is corrupted at one point, another entry with the correct CRC is considered as a valid value
 - 7 bytes (4 bytes: kWh, 2 bytes: impulse count and 1 byte: CRC): total cumulative energy entry
- Cumulative energy until last month
 - Cumulative energy until last month states energy consumed up to the last calendar month reset
 - 6 bytes (4 bytes: kWh and 2 bytes: impulse count): cumulative energy entry up to last month
- Monthly maximum demand
 - 3 bytes (1 byte: integer value and 2 bytes: impulse count): MD value, 3 bytes (date) 3 bytes (time)
- Current monthly cumulative energy
 - Current monthly cumulative energy states energy consumed in that particular current month until the last calendar month reset
 - 6 bytes (4 bytes: kWh and 2 bytes: impulse count), current cumulative energy entry
- Monthly average PF
 - PF average value is the sum of PF readings and PF averaging count is the number of PF readings. 4 bytes (PF average value) 2 bytes (PF averaging value)
- Monthly tamper log
 - For the monthly tamper log, the following four types of tamper data are logged:
 - Earth tamper
 - Reverse tamper
 - Neutral missing tamper
 - Case tamper
 - For each tamper, there are 4 entries per month:
 - 1 byte: tamper count
 - 3 bytes: date
 - 3 bytes: time.

*Note: For each tamper entry log, the tamper count: number of tampers in month
D: date and T: time is of 3 bytes.*

Appendix A Tamper definitions

- Earth tamper: using earth in place of neutral (load current is passed partially or fully through earth)
- Reverse connection: reversal of phase and neutral at mains
- Neutral missing tamper: when neutral is disconnected, the board is not powered. During this condition (single wire conditions), power supply is generated by a CT for powering up the board
- Case tamper: if an attempt is made to open the meter body, the meter logs the date/time of the meter opening tamper
- Magnetic tamper: if a magnet is near to the board, it pulls magnetic sensor output IO low.



Appendix B BOM list and schematics

Table 7. BOM

Category	Reference designator	Component description	Package	Manufacturer	Manufacturer's ordering code / orderable part number	Supplier ordering code
ST devices	U1	STPM metering engine	TSSOP20	STMicroelectronics	STPM10BTR	STPM10BTR
	U2	STM8L microcontroller	LQFP48	STMicroelectronics	STM8L152C6T6	STM8L152C6T6
	U3	EEPROM 32 Kb	SO8	STMicroelectronics	M24C32-RDW6P	M24C32-RDW6P
	U5	Voltage reference	TO92	STMicroelectronics	TL431AIZ	TL431AIZ
	D5,D11,D12,D13,D14	Small signal diode	SOD-523	STMicroelectronics	BAT30KFILM	BAT30KFILM
Crystal and oscillator	Y1	4194.304 kHz oscillator	2-pin (3.5 mm)	ECS Inc	ECS-42-12-4X	X1046-ND
	Y2	32.768 kHz oscillator	2-pin (cylindrical)	Abracon Corporation	AB26T-32.768 KHZ	535-9032-ND
Connectors and jumpers	J1	Swim connector (SMT, 4-pin, 1.27 mm pitch)	SMD	ERNI	ERNI	284697
	J2,J4	3-pin connector	3-pin (2.54 mm)		Any	
	J5	4-pin connector	4-pin (2.54 mm)		Any	
	J6	2-pin connector	2-pin (2.54 mm)		Any	
LEDs	D10	LED	Leaded (3 mm)		HLMP-K150	516-1311-ND



Table 7. BOM (continued)

Category	Reference designator	Component description	Package	Manufacturer	Manufacturer's ordering code / orderable part number	Supplier ordering code
Capacitors	C1,C3,C4,C20,C23,C27	1 μ F	SMD0805		Any	
	C2,C29	1 nF	SMD0805		Any	
	C5,C14,C15,C17,C21,C22,C24,C28,C31	100 nF	SMD0805		Any	
	C6,C8	15 pF	SMD0805		Any	
	C7,C10	10 nF	SMD0805		Any	
	C9,C11	12 pF	SMD0805		Any	
	C12	4.7 μ F	SMD1206		Any	
	C16,C30	4.7 μ F	Tantulum SMD EIA 3216-18/ size A	Any		
	C13	33 nF	SMD0805		Any	
	C18	200 nF/630 V	Leaded	Vishay/BC Components	BFC2 383 20204	BC1857-ND
	C19	220 μ F/16 V	Leaded	Panasonic - ECG	EEU-FC1C221	P11199-ND
	C25	1 nF/500 V	Leaded	Vishay/BC Components	D102K25Y5PL63L6R	1457PH-ND
	C26	100 μ F/50 V	Leaded	Panasonic - ECG	ECE-A1HN101U	P1284-ND
	C32	6.8 μ F/16 V	Leaded	Panasonic - ECG	ECE-A1CKG6R8	P909-ND
C33	470 μ F/35 V	Leaded	Nichicon	UVR1V471MPD	493-1084-ND	

**Table 7. BOM (continued)**

Category	Reference designator	Component description	Package	Manufacturer	Manufacturer's ordering code / orderable part number	Supplier ordering code
Resistors	R1,R13,R17,R18, R36,R37,R41	10 k Ω	SMD0805		Any	
	R2	1 M Ω	SMD0805		Any	
	R3,R11,R20,R21, R27,R33,R34,R35	0	SMD0805		Any	
	R4,R10,R14,R19, R32	1 k Ω	SMD0805		Any	
	R5	6.8 Ω	SMD0805		Any	



Table 7. BOM (continued)

Category	Reference designator	Component description	Package	Manufacturer	Manufacturer's ordering code / orderable part number	Supplier ordering code
Resistors	R6	27 Ω	SMD0805		Any	
	R7	42.2 k Ω	SMD0805		Any	
	R9,R15	2 M Ω	SMD0805		Any	
	R12	100 Ω	SMD0805		Any	
	R16	2.2 k Ω	SMD0805		Any	
	R22	100 k Ω	SMD0805		Any	
	R23,R24,R25	261 k Ω	SMD1206		Any	
	R26	475 Ω	SMD0805		Any	
	R28	82, 2 W	Leaded	Yageo	RSF200JB-82R	82W-2-ND
	R29	15 k Ω	SMD0805		Any	
	R30	22 k Ω	SMD0805		Any	
	R31	470 Ω	SMD0805		Any	
	R38	5.1 Ω	SMD0805		Any	
	R39	150, 2 W	Leaded	Vishay/BC components	PR02000201500JR500	PPC150W-2CT-ND
	R40	8 k Ω	SMD0805		Any	
R41	10 k Ω	SMD0805		Any		
Inductors	L1	220 μ H	SMD	Panasonic - ECG	ELJ-FB221JF	PCD1469CT-ND
	L2, L3	1 μ H	SMD	Panasonic - ECG	ELJ-FC1R0JF	PCD1228CT-ND
Diode	D1,D2,D3,D4,D6,D7,D8,D9	Diode GPP 1A 1000 V DO41	Leaded	Fairchild Semiconductor	1N4007	1N4007FSCT-ND



Table 7. BOM (continued)

Category	Reference designator	Component description	Package	Manufacturer	Manufacturer's ordering code / orderable part number	Supplier ordering code
Misc components	U6	Infrared transceiver module (SIR, 115.2 kbit/s)	SMD-8pin	Vishay Electronics	TFDU4300	751-1073-1-ND
	U4	Micropower omnipolar Hall-effect sensor switch	SC-59-3L	Diodes Inc.	AH180_SC59-3L	AH180-WGDICT-ND
Misc components	SW1	Reset switch for micro	Leaded	Tyco Electronics	1555986	FSM10JH
	SW2	Case tamper switch	Leaded	Tyco Electronics	1555986	FSM10JH
	SW3	LCD_PUSH switch	Leaded	Tyco Electronics	1555986	FSM10JH
	J3	LCD glass 18x4	22-pin connector		OPT6089A	PIE Electronics
	MOV1	SUR ABSORBER 10 MM 750V 2500 A ZNR	Leaded	Panasonic - ECG	ERZ-V10D751	P7260-ND
	RS1	Current sensing resistors 5 WATT .0005OHM 1 %	Leaded	IRC	CSL-5R0005F0002LF	66-CSL-5R0005FLF
	CT1	Current transformer	Leaded	Vacuumschmelze (Vac)	T60404-E4623-X002	T60404-E4623-X002
	BAT1	Battery lithium Coin 3 V W/TABS	Leaded	Panasonic - BSG	CR-2032/F4N	P245-ND
	BAT2	Battery lithium Coin 3 V 23 MM 50 MA VERT	Leaded	Panasonic - BSG	VL-2330/VCN	P086-ND
	Q1	Transistor NPN 45 V 0.1 A SOT23	SOT23	Fairchild Semiconductor	BC847BMTF	BC847BMTFCT-ND

Figure 8. Microcontroller schematic

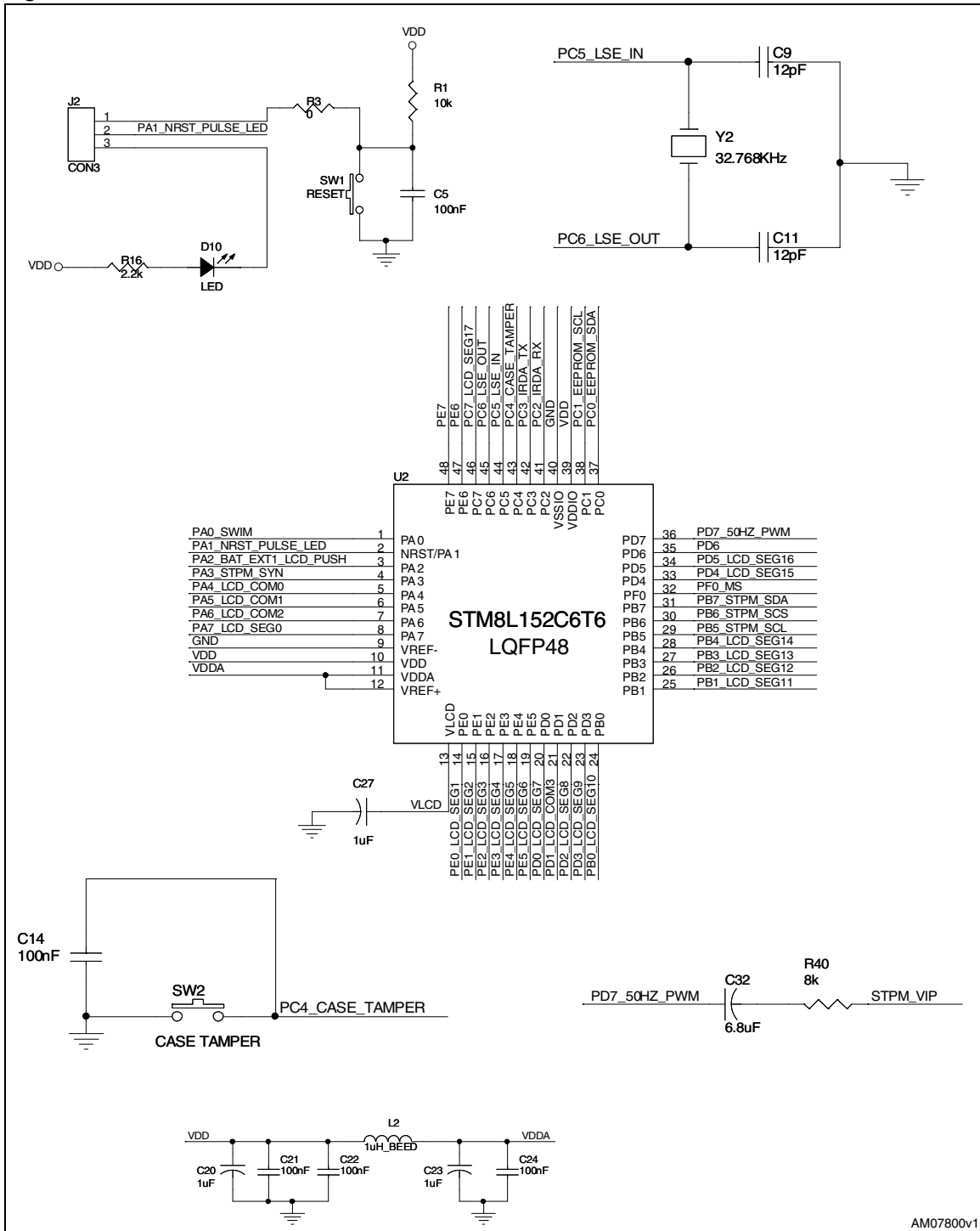

AM07800v1

Figure 9. Battery, connector, magnetic sensor and IrDA module schematics

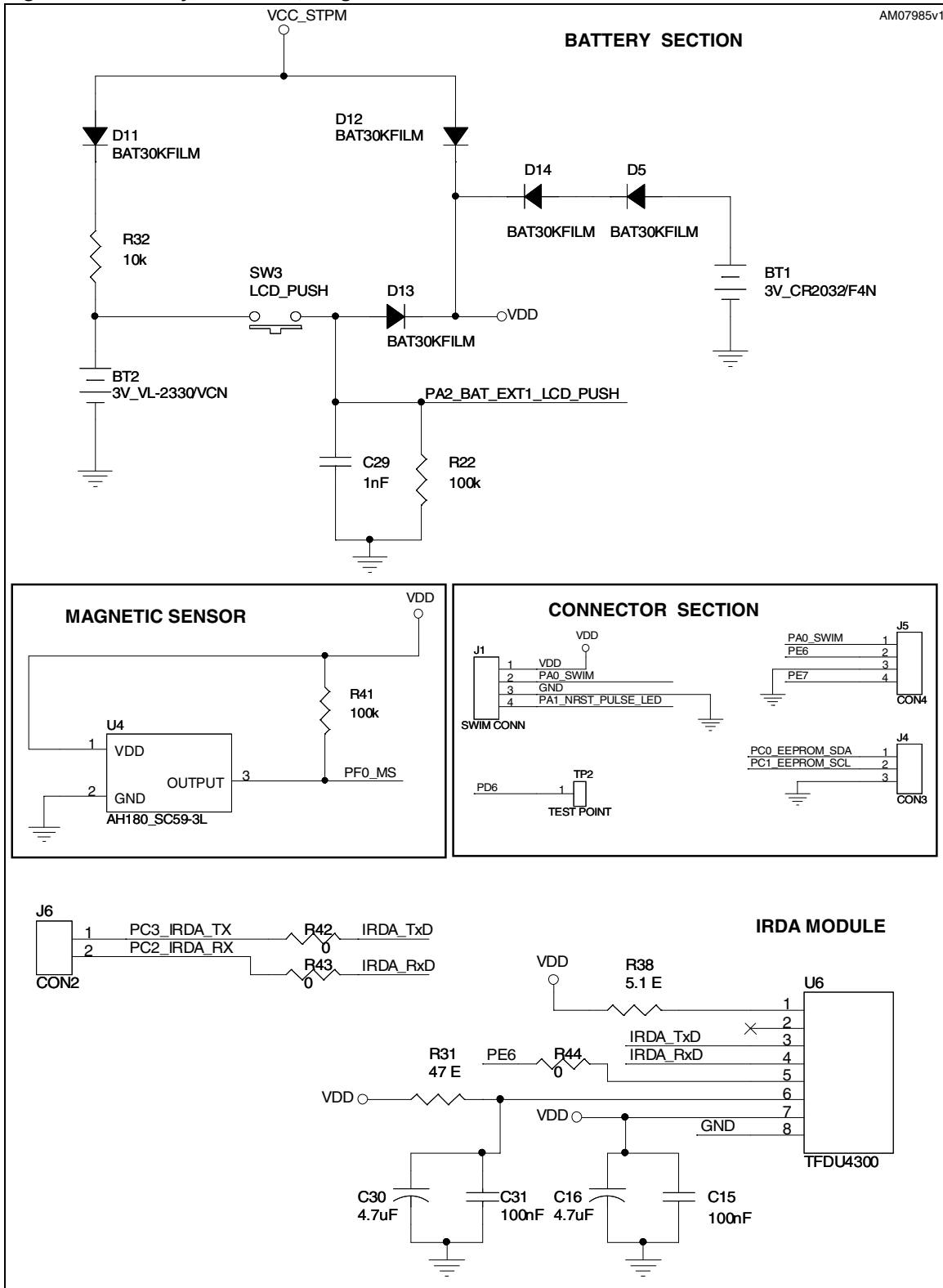
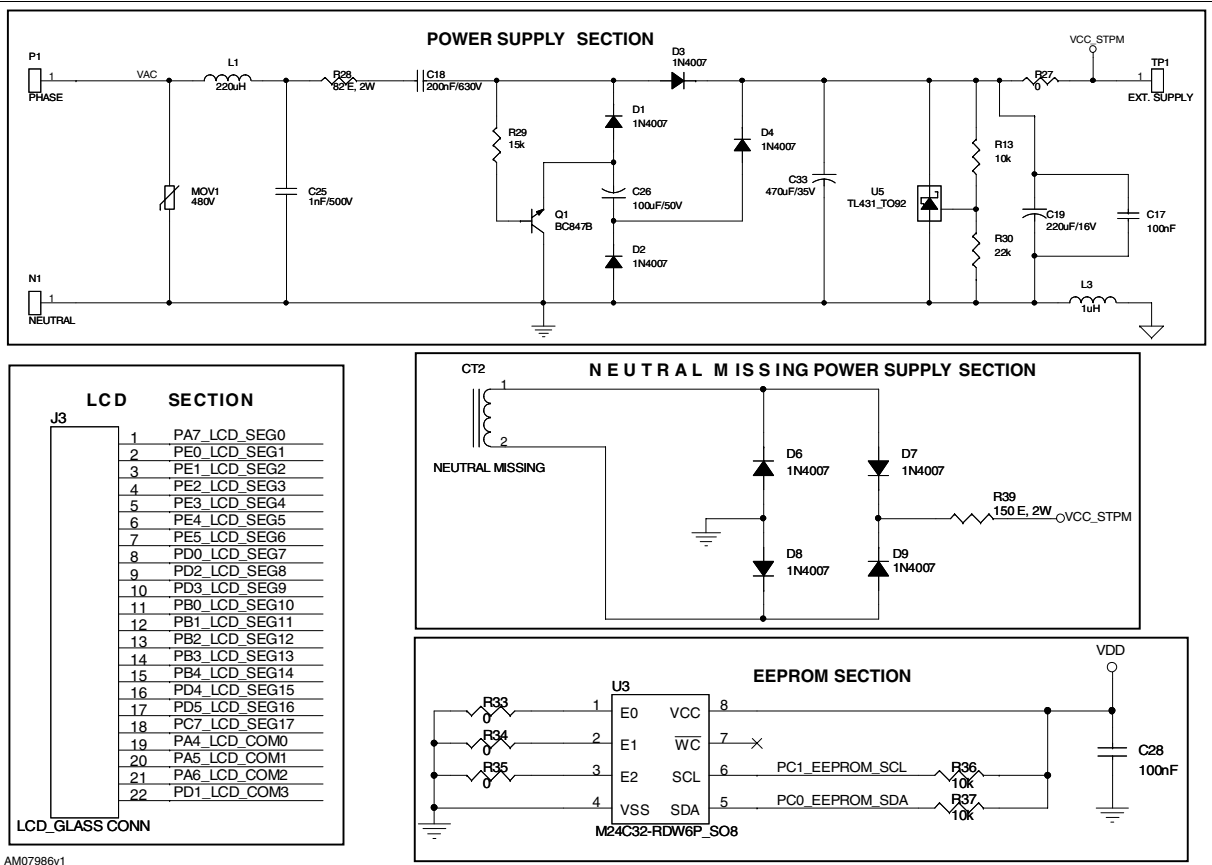



Figure 10. Power supply, EEPROM, LCD and neutral missing power supply schematics



AM07986v1



Figure 11. STPM schematic

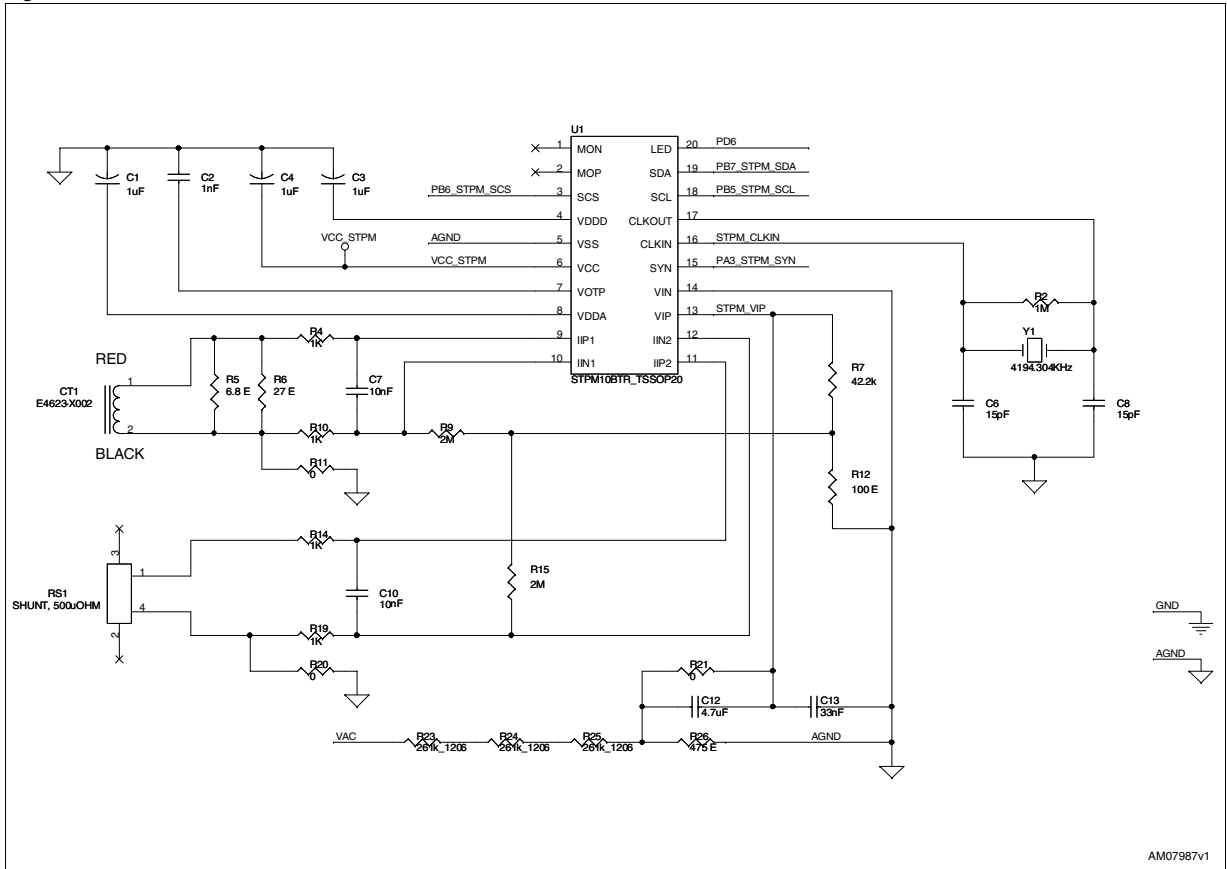

Doc ID 17778 Rev 1

32/34

UM0981

BOM list and schematics

Revision history

Table 8. Document revision history

Date	Revision	Changes
23-Nov-2010	1	Initial release.

Please Read Carefully:

Information in this document is provided solely in connection with ST products. STMicroelectronics NV and its subsidiaries ("ST") reserve the right to make changes, corrections, modifications or improvements, to this document, and the products and services described herein at any time, without notice.

All ST products are sold pursuant to ST's terms and conditions of sale.

Purchasers are solely responsible for the choice, selection and use of the ST products and services described herein, and ST assumes no liability whatsoever relating to the choice, selection or use of the ST products and services described herein.

No license, express or implied, by estoppel or otherwise, to any intellectual property rights is granted under this document. If any part of this document refers to any third party products or services it shall not be deemed a license grant by ST for the use of such third party products or services, or any intellectual property contained therein or considered as a warranty covering the use in any manner whatsoever of such third party products or services or any intellectual property contained therein.

UNLESS OTHERWISE SET FORTH IN ST'S TERMS AND CONDITIONS OF SALE ST DISCLAIMS ANY EXPRESS OR IMPLIED WARRANTY WITH RESPECT TO THE USE AND/OR SALE OF ST PRODUCTS INCLUDING WITHOUT LIMITATION IMPLIED WARRANTIES OF MERCHANTABILITY, FITNESS FOR A PARTICULAR PURPOSE (AND THEIR EQUIVALENTS UNDER THE LAWS OF ANY JURISDICTION), OR INFRINGEMENT OF ANY PATENT, COPYRIGHT OR OTHER INTELLECTUAL PROPERTY RIGHT.

UNLESS EXPRESSLY APPROVED IN WRITING BY AN AUTHORIZED ST REPRESENTATIVE, ST PRODUCTS ARE NOT RECOMMENDED, AUTHORIZED OR WARRANTED FOR USE IN MILITARY, AIR CRAFT, SPACE, LIFE SAVING, OR LIFE SUSTAINING APPLICATIONS, NOR IN PRODUCTS OR SYSTEMS WHERE FAILURE OR MALFUNCTION MAY RESULT IN PERSONAL INJURY, DEATH, OR SEVERE PROPERTY OR ENVIRONMENTAL DAMAGE. ST PRODUCTS WHICH ARE NOT SPECIFIED AS "AUTOMOTIVE GRADE" MAY ONLY BE USED IN AUTOMOTIVE APPLICATIONS AT USER'S OWN RISK.

Resale of ST products with provisions different from the statements and/or technical features set forth in this document shall immediately void any warranty granted by ST for the ST product or service described herein and shall not create or extend in any manner whatsoever, any liability of ST.

ST and the ST logo are trademarks or registered trademarks of ST in various countries.

Information in this document supersedes and replaces all information previously supplied.

The ST logo is a registered trademark of STMicroelectronics. All other names are the property of their respective owners.

© 2010 STMicroelectronics - All rights reserved

STMicroelectronics group of companies

Australia - Belgium - Brazil - Canada - China - Czech Republic - Finland - France - Germany - Hong Kong - India - Israel - Italy - Japan - Malaysia - Malta - Morocco - Philippines - Singapore - Spain - Sweden - Switzerland - United Kingdom - United States of America

www.st.com