

Embedded Memory LCD Controller
S1D13705F00A
Technical Manual

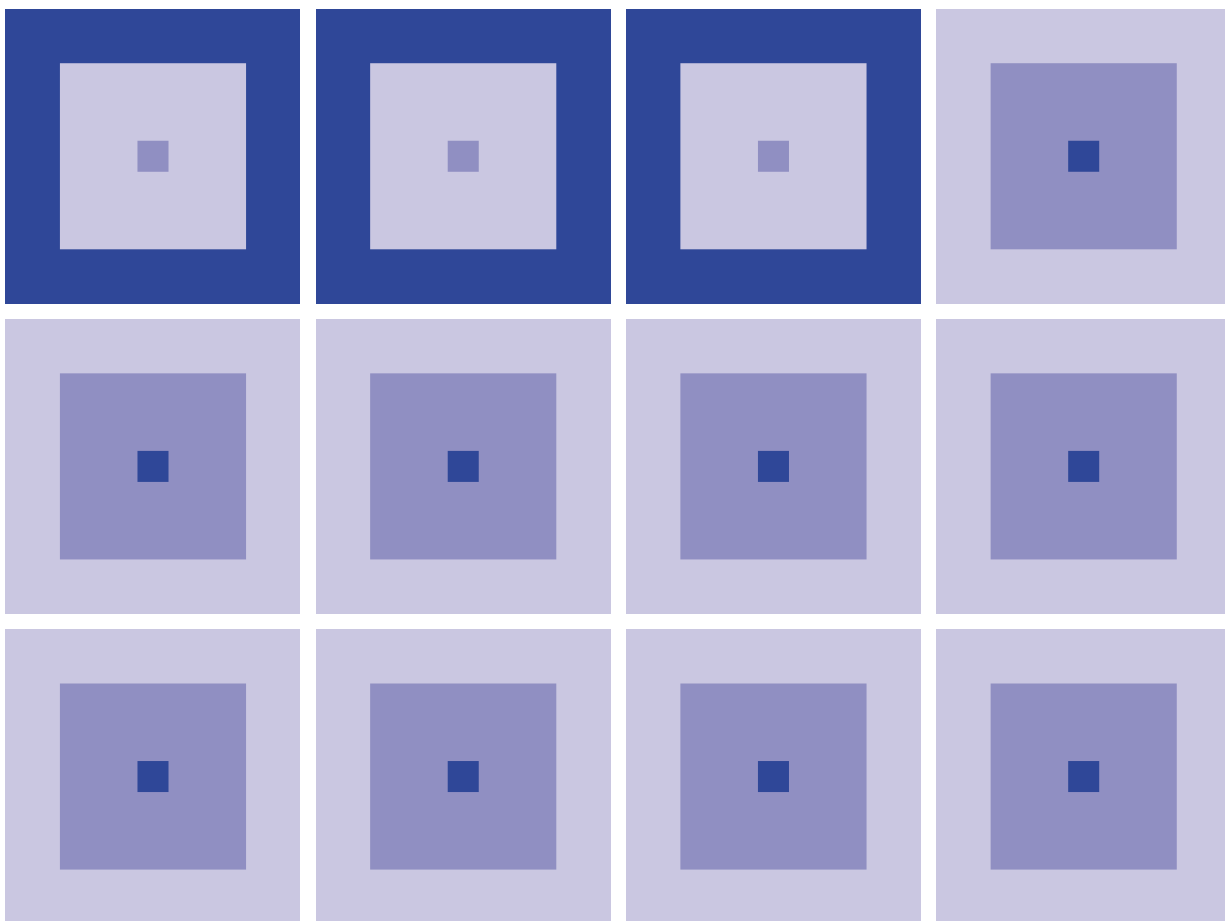

NOTICE

No part of this material may be reproduced or duplicated in any form or by any means without the written permission of Seiko Epson. Seiko Epson reserves the right to make changes to this material without notice. Seiko Epson does not assume any liability of any kind arising out of any inaccuracies contained in this material or due to its application or use in any product or circuit and, further, there is no representation that this material is applicable to products requiring high level reliability, such as medical products. Moreover, no license to any intellectual property rights is granted by implication or otherwise, and there is no representation or warranty that anything made in accordance with this material will be free from any patent or copyright infringement of a third party. This material or portions thereof may contain technology or the subject relating to strategic products under the control of the Foreign Exchange and Foreign Trade Law of Japan and may require an export license from the Ministry of International Trade and Industry or other approval from another government agency.

MS-DOS and Windows are registered trademarks of Microsoft Corporation, U.S.A.
PC-DOS, PC/AT, VGA, EGA and IBM are registered trademarks of International Business Machines Corporation, U.S.A.
All other product names mentioned herein are trademarks and/or registered trademarks of their respective owners.

The information of the product number change

Starting April 1, 2001, the product number will be changed as listed below. To order from April 1, 2001 please use the new product number. For further information, please contact Epson sales representative.

Configuration of product number

● Devices

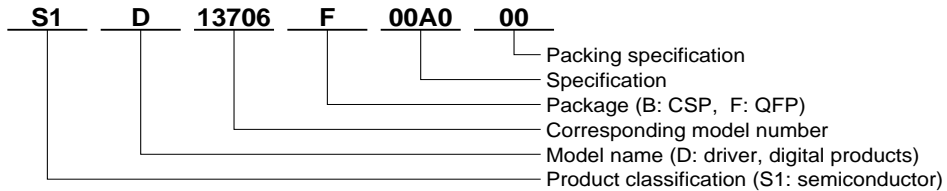

● Evaluation Board

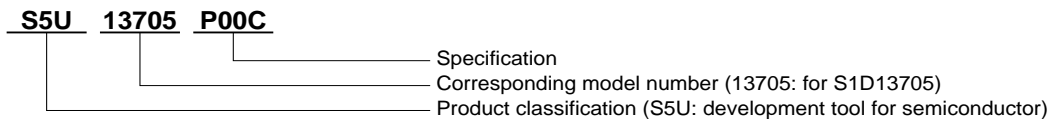

Comparison table between new and previous number

• S1D13305 Series

Previous No.	New No.
SED1335 Series	S1D13305 Series
SED1335D0A	S1D13305D00A
SED1335F0A	S1D13305F00A
SED1335F0B	S1D13305F00B

• S1D1370x Series

Previous No.	New No.
SED137x Series	S1D1370x Series
SED1374F0A	S1D13704F00A
SED1375F0A	S1D13705F00A
SED1376B0A	S1D13706B00A
SED1376F0A	S1D13706F00A
SED1378 Series	S1D13708 Series

• S1D1380x Series

Previous No.	New No.
SED138x Series	S1D1380x Series
SED1386F0A	S1D13806F00A

• S1D1350x Series

Previous No.	New No.
SED135x Series	S1D1350x Series
SED1353D0A	S1D13503D00A
SED1353F0A	S1D13503F00A
SED1353F1A	S1D13503F01A
SED1354F0A	S1D13504F00A
SED1354F1A	S1D13504F01A
SED1354F2A	S1D13504F02A
SED1355F0A	S1D13505F00A
SED1356F0A	S1D13506F00A

• S1D13A0x Series

Previous No.	New No.
SED13Ax Series	S1D13A0x Series
SED13A3F0A	S1D13A03F00A
SED13A3B0B	S1D13A03B00B
SED13A4B0B	S1D13A04B00B

Comparison table between new and previous number of Evaluation Boards

• S1D1350x Series

Previous No.	New No.
SDU1353#0C	S5U13503P00C
SDU1354#0C	S5U13504P00C
SDU1355#0C	S5U13505P00C
SDU1356#0C	S5U13506P00C

• S1D1370x Series

Previous No.	New No.
SDU1374#0C	S5U13704P00C
SDU1375#0C	S5U13705P00C
SDU1376#0C	S5U13706P00C
SDU1376BVR	S5U1370632R
SDU1378#0C	S5U13708P00C

• S1D1380x Series

Previous No.	New No.
SDU1386#0C	S5U13806P00C

• S1D13A0x Series

Previous No.	New No.
SDU13A3#0C	S5U13A03P00C
SDU13A4#0C	S5U13A04P00C

S1D13705F00A Technical Manual

HARDWARE FUNCTIONAL SPECIFICATION

PROGRAMMING NOTES AND EXAMPLES

UTILITIES

**S5U13705B00C ISA BUS EVALUATION
BOARD USER'S MANUAL**

APPLICATION NOTES

WINDOWS® CE DISPLAY DRIVERS

S1D13705F00A
Embedded Memory LCD Controller
Hardware Functional
Specification

1	INTRODUCTION	1-1
1.1	Scope	1-1
1.2	Overview Description	1-1
2	FEATURES	1-2
2.1	Integrated Frame Buffer	1-2
2.2	CPU Interface	1-2
2.3	Display Support	1-2
2.4	Display Modes	1-2
2.5	Clock Source	1-3
2.6	Miscellaneous	1-3
2.7	Package	1-3
3	TYPICAL SYSTEM IMPLEMENTATION DIAGRAMS	1-4
4	FUNCTIONAL BLOCK DIAGRAM	1-7
4.1	Functional Block Descriptions	1-7
4.1.1	Host Interface	1-7
4.1.2	Memory Controller	1-7
4.1.3	Sequence Controller	1-7
4.1.4	Look-Up Table	1-7
4.1.5	LCD Interface	1-8
4.1.6	Power Save	1-8
5	PINS	1-9
5.1	Pinout Diagram	1-9
5.2	Pin Description	1-10
5.2.1	Host Interface	1-10
5.2.2	LCD Interface	1-12
5.2.3	Clock Input	1-12
5.2.4	Miscellaneous	1-12
5.2.5	Power Supply	1-12
5.3	Summary of Configuration Options	1-13
5.4	Host Bus Interface Pin Mapping	1-13
5.5	LCD Interface Pin Mapping	1-14
6	D.C. CHARACTERISTICS	1-15
7	A.C. CHARACTERISTICS	1-17
7.1	Bus Interface Timing	1-17
7.1.1	SH-4 Interface Timing	1-17
7.1.2	SH-3 Interface Timing	1-19
7.1.3	Motorola MC68K #1 Interface Timing	1-20
7.1.4	Motorola MC68K #2 Interface Timing	1-21
7.1.5	Generic #1 Interface Timing	1-22
7.1.6	Generic #2 Interface Timing	1-23
7.2	Clock Input Requirements	1-24
7.3	Display Interface	1-25
7.3.1	Power On/Reset Timing	1-25
7.3.2	Power Down/Up Timing	1-26
7.3.3	4-Bit Single Monochrome Panel Timing	1-27
7.3.4	8-Bit Single Monochrome Panel Timing	1-29
7.3.5	4-Bit Single Color Panel Timing	1-31
7.3.6	8-Bit Single Color Panel Timing (Format 1)	1-33
7.3.7	8-Bit Single Color Panel Timing (Format 2)	1-35
7.3.8	8-Bit Dual Monochrome Panel Timing	1-37
7.3.9	8-Bit Dual Color Panel Timing	1-39
7.3.10	12-Bit TFT/D-TFD Panel Timing	1-41

- 8 REGISTERS.....1-44**
 - 8.1 Register Mapping..... 1-44
 - 8.2 Register Descriptions..... 1-44
- 9 FRAME RATE CALCULATION.....1-56**
- 10 DISPLAY DATA FORMATS.....1-57**
- 11 LOOK-UP TABLE ARCHITECTURE.....1-58**
 - 11.1 Monochrome Modes 1-58
 - 11.1.1 1 Bit-per-pixel Monochrome Mode..... 1-58
 - 11.1.2 2 Bit-per-pixel Monochrome Mode..... 1-58
 - 11.1.3 4 Bit-per-pixel Monochrome Mode..... 1-59
 - 11.2 Color Modes..... 1-60
 - 11.2.1 1 Bit-per-pixel Color Mode 1-60
 - 11.2.2 2 Bit-per-pixel Color Mode 1-61
 - 11.2.3 4 Bit-per-pixel Color Mode 1-62
 - 11.2.4 8 Bit-per-pixel Color Mode 1-63
- 12 SWIVELVIEW MODE.....1-64**
 - 12.1 Default SwivelView Mode..... 1-64
 - 12.1.1 How to Set Up Default SwivelView Mode 1-65
 - 12.2 Alternate SwivelView Mode..... 1-66
 - 12.2.1 How to Set Up Alternate SwivelView Mode 1-67
 - 12.3 Comparison Between Default and Alternate SwivelView Modes 1-68
 - 12.4 SwivelView Mode Limitations..... 1-68
- 13 POWER SAVE MODES.....1-69**
 - 13.1 Software Power Save Mode..... 1-69
 - 13.2 Hardware Power Save Mode 1-69
 - 13.3 Power Save Mode Function Summary..... 1-69
 - 13.4 Panel Power Up/Down Sequence..... 1-70
 - 13.5 Turning Off BCLK Between Accesses 1-70
 - 13.6 Clock Requirements..... 1-71
- 14 MECHANICAL DATA1-72**

List of Figures

Figure 3-1	Typical System Diagram (SH-4 Bus).....	1-4
Figure 3-2	Typical System Diagram (SH-3 Bus).....	1-4
Figure 3-3	Typical System Diagram (M68K #1 Bus)	1-5
Figure 3-4	Typical System Diagram (M68K #2 Bus)	1-5
Figure 3-5	Typical System Diagram (Generic #1 Bus)	1-6
Figure 3-6	Typical System Diagram (Generic #2 Bus - e.g. ISA Bus)	1-6
Figure 4-1	System Block Diagram Showing Data Paths	1-7
Figure 5-1	Pinout Diagram.....	1-9
Figure 7-1	SH-4 Timing	1-17
Figure 7-2	SH-3 Bus Timing	1-19
Figure 7-3	MC68K #1 Bus Timing (MC68000)	1-20
Figure 7-4	MC68K #2 Timing (MC68030).....	1-21
Figure 7-5	Generic #1 Timing	1-22
Figure 7-6	Generic #2 Timing	1-23
Figure 7-7	Clock Input Requirements	1-24
Figure 7-8	LCD Panel Power On/Reset Timing.....	1-25
Figure 7-9	Power Down/Up Timing.....	1-26
Figure 7-10	4-Bit Single Monochrome Panel Timing	1-27
Figure 7-11	4-Bit Single Monochrome Panel A.C. Timing	1-28
Figure 7-12	8-Bit Single Monochrome Panel Timing	1-29
Figure 7-13	8-Bit Single Monochrome Panel A.C. Timing	1-30
Figure 7-14	4-Bit Single Color Panel Timing	1-31
Figure 7-15	4-Bit Single Color Panel A.C. Timing	1-32
Figure 7-16	8-Bit Single Color Panel Timing (Format 1).....	1-33
Figure 7-17	8-Bit Single Color Panel A.C. Timing (Format 1).....	1-34
Figure 7-18	8-Bit Single Color Panel Timing (Format 2).....	1-35
Figure 7-19	8-Bit Single Color Panel A.C. Timing (Format 2).....	1-36
Figure 7-20	8-Bit Dual Monochrome Panel Timing.....	1-37
Figure 7-21	8-Bit Dual Monochrome Panel A.C. Timing.....	1-38
Figure 7-22	8-Bit Dual Color Panel Timing	1-39
Figure 7-23	8-Bit Dual Color Panel A.C. Timing	1-40
Figure 7-24	12-Bit TFT/D-TFD Panel Timing.....	1-41
Figure 7-25	TFT/D-TFD A.C. Timing	1-42
Figure 8-1	Screen-Register Relationship.....	1-52
Figure 10-1	1/2/4/8 Bit-Per-Pixel Display Data Memory Organization.....	1-57
Figure 11-1	1 Bit-per-pixel Monochrome Mode Data Output Path	1-58
Figure 11-2	2 Bit-per-pixel Monochrome Mode Data Output Path	1-58
Figure 11-3	4 Bit-per-pixel Monochrome Mode Data Output Path	1-59
Figure 11-4	1 Bit-per-pixel Color Mode Data Output Path.....	1-60
Figure 11-5	2 Bit-per-pixel Color Mode Data Output Path.....	1-61
Figure 11-6	4 Bit-per-pixel Color Mode Data Output Path.....	1-62
Figure 11-7	8 Bit-per-pixel Color Mode Data Output Path.....	1-63
Figure 12-1	Relationship Between The Screen Image and the Image Refreshed by S1D13705 in Default Mode1-64	
Figure 12-2	Relationship Between The Screen Image and the Image Refreshed by S1D13705 in Alternate Mode1-66	
Figure 13-1	Panel On/Off Sequence	1-70
Figure 14-1	Mechanical Drawing QFP14.....	1-72

List of Tables

Table 5-1	Host Interface Pin Descriptions.....	1-10
Table 5-2	LCD Interface Pin Descriptions.....	1-12
Table 5-3	Clock Input Pin Description.....	1-12
Table 5-4	Miscellaneous Pin Descriptions.....	1-12
Table 5-5	Power Supply Pin Descriptions.....	1-12
Table 5-6	Summary of Power On/Reset Options.....	1-13
Table 5-7	Host Bus Interface Pin Mapping.....	1-13
Table 5-8	LCD Interface Pin Mapping.....	1-14
Table 6-1	Absolute Maximum Ratings.....	1-15
Table 6-2	Recommended Operating Conditions for Core VDD = 3.3V ± 10%.....	1-15
Table 6-3	Input Specifications.....	1-15
Table 6-4	Output Specifications.....	1-16
Table 7-1	SH-4 Timing.....	1-18
Table 7-2	SH-3 Bus Timing.....	1-19
Table 7-3	MC68K #1 Bus Timing (MC68000).....	1-20
Table 7-4	MC68K #2 Timing (MC68030).....	1-21
Table 7-5	Generic #1 Timing.....	1-22
Table 7-6	Generic #2 Timing.....	1-23
Table 7-7	Clock Input Requirements.....	1-24
Table 7-8	LCD Panel Power On/Reset Timing.....	1-25
Table 7-9	Power Down/Up Timing.....	1-26
Table 7-10	4-Bit Single Monochrome Panel A.C. Timing.....	1-28
Table 7-11	8-Bit Single Monochrome Panel A.C. Timing.....	1-30
Table 7-12	4-Bit Single Color Panel A.C. Timing.....	1-32
Table 7-13	8-Bit Single Color Panel A.C. Timing (Format 1).....	1-34
Table 7-14	8-Bit Single Color Panel A.C. Timing (Format 2).....	1-36
Table 7-15	8-Bit Dual Monochrome Panel A.C. Timing.....	1-38
Table 7-16	8-Bit Dual Color Panel A.C. Timing.....	1-40
Table 7-17	TFT/D-TFD A.C. Timing.....	1-43
Table 8-1	Panel Data Format.....	1-45
Table 8-2	Gray Scale/Color Mode Selection.....	1-45
Table 8-3	High Performance Selection.....	1-46
Table 8-4	Inverse Video Mode Select Options.....	1-46
Table 8-5	Hardware Power Save/GPIO0 Operation.....	1-47
Table 8-6	Software Power Save Mode Selection.....	1-47
Table 8-7	Selection of Portrait Mode.....	1-54
Table 8-8	Selection of PCLK and MCLK in Portrait Mode.....	1-54
Table 12-1	Default and Alternate SwivelView Mode Comparison.....	1-68
Table 13-1	Power Save Mode Selection.....	1-69
Table 13-2	Software Power Save Mode Summary.....	1-69
Table 13-3	Hardware Power Save Mode Summary.....	1-69
Table 13-4	Power Save Mode Function Summary.....	1-69
Table 13-5	S1D13705 Internal Clock Requirements.....	1-71

1 INTRODUCTION

1.1 Scope

This is the Hardware Functional Specification for the S1D13705 Embedded Memory LCD Controller Chip. Included in this document are timing diagrams, AC and DC characteristics, register descriptions, and power management descriptions. This document is intended for two audiences: Video Subsystem Designers and Software Developers.

1.2 Overview Description

The S1D13705 is a color / monochrome LCD graphics controller with an embedded 80K byte SRAM display buffer. The high integration of the S1D13705 provides a low cost, low power, single chip solution to meet the requirements of embedded markets such as Office Automation equipment, Mobile Communications devices, and Hand-Held PCs where board size and battery life are major concerns.

Products requiring a “Portrait” display can take advantage of the Hardware Portrait Mode feature of the S1D13705. Virtual and Split Screen are just some of the display modes supported. The above features, combined with the Operating System independence of the S1D13705, make it the ideal solution for a wide variety of applications.

2 *FEATURES*

2.1 *Integrated Frame Buffer*

- Embedded 80K byte SRAM display buffer.

2.2 *CPU Interface*

- Direct support of the following interfaces:
 - Hitachi SH-3.
 - Hitachi SH-4.
 - Motorola M68K.
 - MPU bus interface using WAIT# signal.
- Direct memory mapping of internal registers.
- Single level CPU write buffer.
- Registers are mapped into upper 32 bytes of 128K byte address space.
- The complete 80K byte display buffer is directly and contiguously available through the 17-bit address bus.

2.3 *Display Support*

- 4/8-bit monochrome LCD interface.
- 4/8-bit color LCD interface.
- Single-panel, single-drive passive displays.
- Dual-panel, dual-drive passive displays.
- Active Matrix TFT / D-TFD interface
- Register level support for EL panels.
- Example resolutions:
 - 640 × 480 at a color depth of 2 bpp
 - 640 × 240 at a color depth of 4 bpp
 - 320 × 240 at a color depth of 8 bpp

2.4 *Display Modes*

- SwivelView™: direct 90° hardware rotation of display image for portrait mode display
- 1/2/4 bit-per-pixel (bpp), 2/4/16-level grayscale display.
- 1/2/4/8 bit-per-pixel, 2/4/16/256-level color display.
- Up to 16 shades of gray by FRM on monochrome passive LCD panels; a 256 × 4 Look-Up Table is used to map 1/2/4 bpp modes into these shades.
- 256 simultaneous of 4096 colors on color passive and active matrix LCD panels; three 256 × 4 Look-Up Tables are used to map 1/2/4/8 bpp modes into these colors.
- Split screen display for all landscape panel modes allows two different images to be simultaneously displayed.
- Virtual display support (displays images larger than the panel size through the use of panning).

2.5 Clock Source

- Maximum operating clock (CLK) frequency of 25MHz.
- Operating clock (CLK) is derived from CLKI input.
CLK = CLKI
or
CLK = CLKI/2
- Pixel Clock (PCLK) and Memory Clock (MCLK) are derived from CLK.

2.6 Miscellaneous

- Hardware/Software Video Invert.
- Software Power Save mode.
- Hardware Power Save mode.
- LCD power-down sequencing.
- 5 General Purpose Input/Output pins are available.
GPIO0 is available if Hardware Power Save is not required.
GPIO[4:1] are available if upper LCD data pins (FPDAT[11:8]) are not required for TFT/D-TFD support or hardware inverse video.
- Core operates from 2.7 volts to 3.6 volts.
- IO Operates from the core voltage up to 5.5 volts.

2.7 Package

- 80 pin QFP14 package.

3 TYPICAL SYSTEM IMPLEMENTATION DIAGRAMS

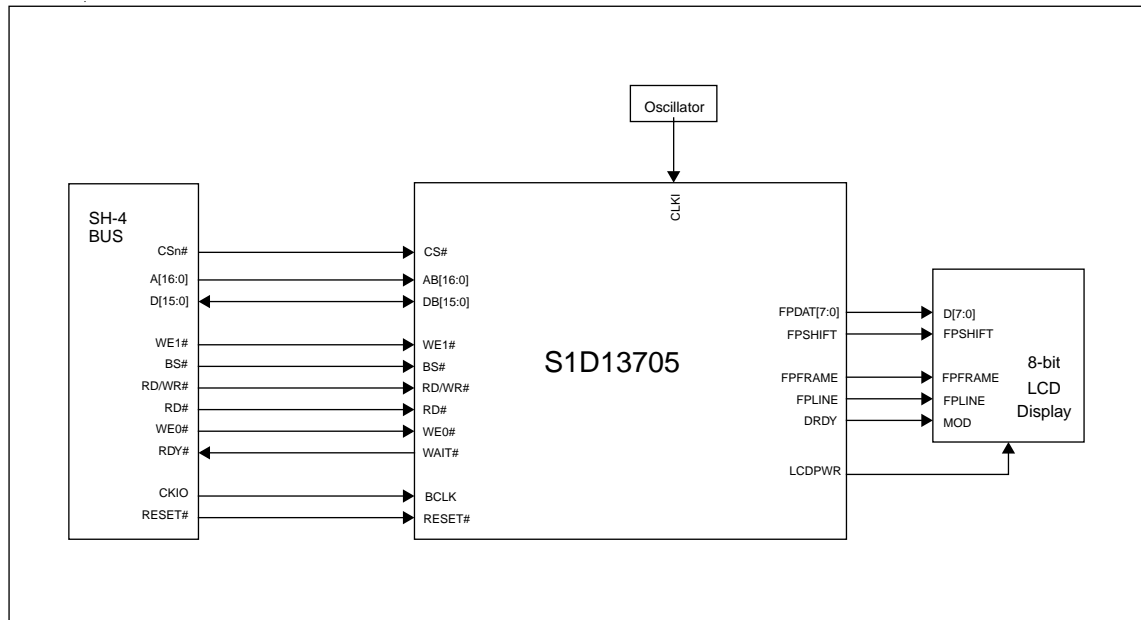

Figure 3-1 Typical System Diagram (SH-4 Bus)

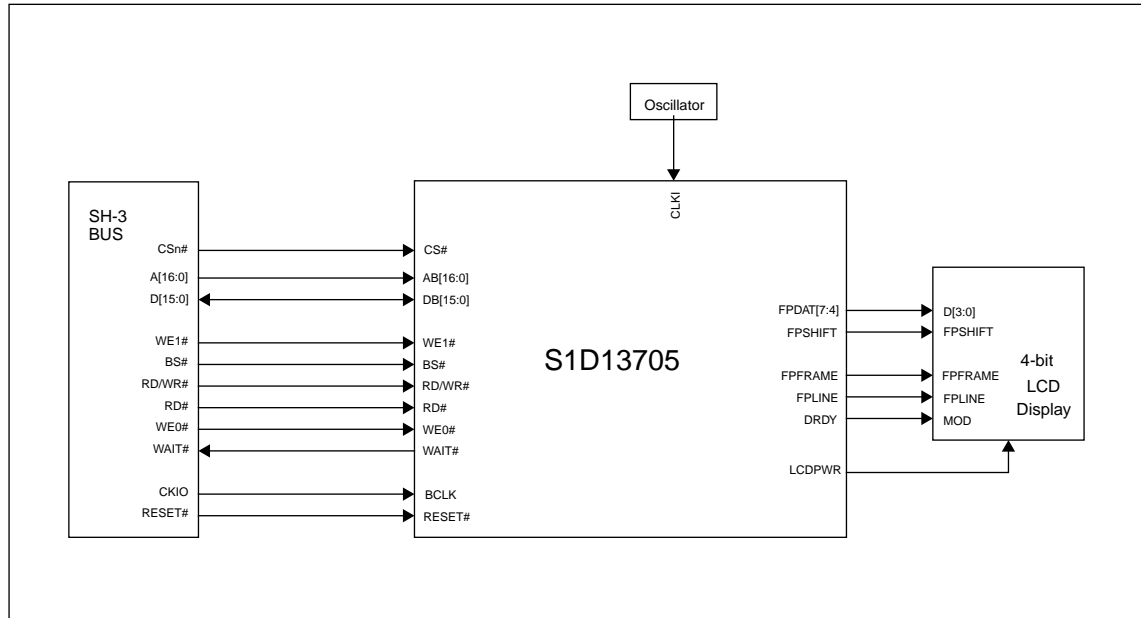

Figure 3-2 Typical System Diagram (SH-3 Bus)

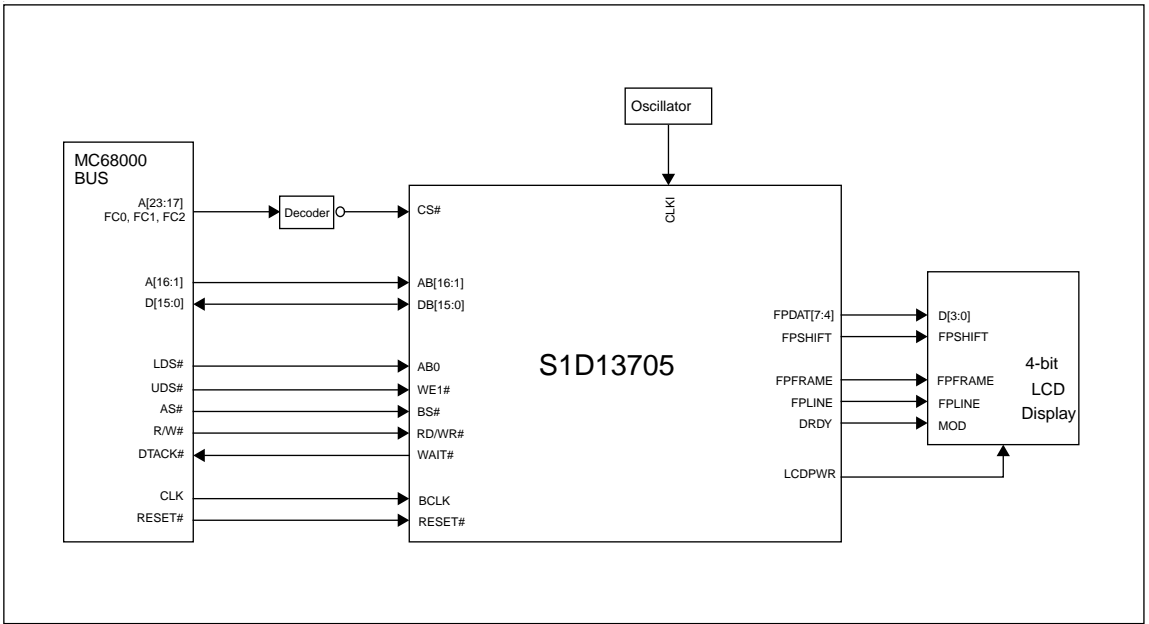

Figure 3-3 Typical System Diagram (M68K #1 Bus)

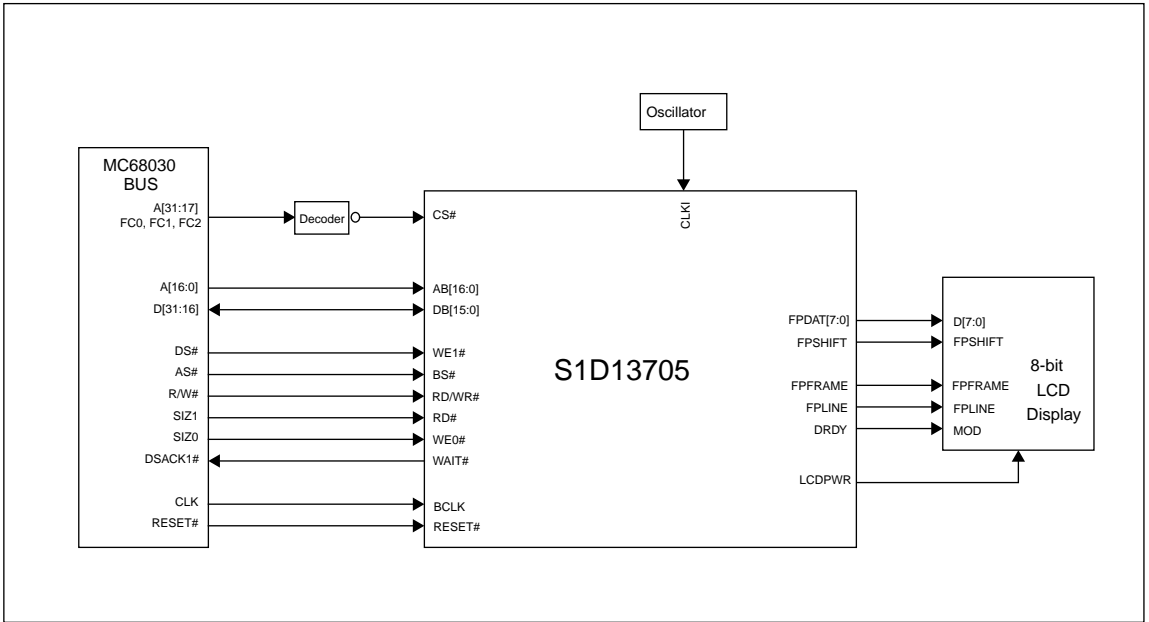

Figure 3-4 Typical System Diagram (M68K #2 Bus)

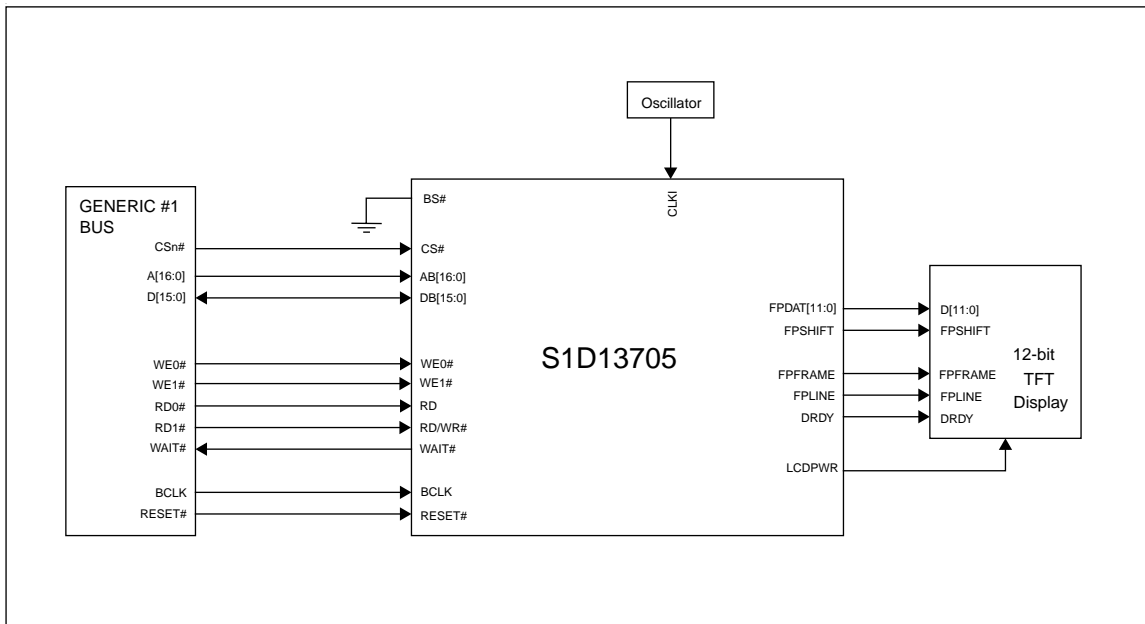

Figure 3-5 Typical System Diagram (Generic #1 Bus)

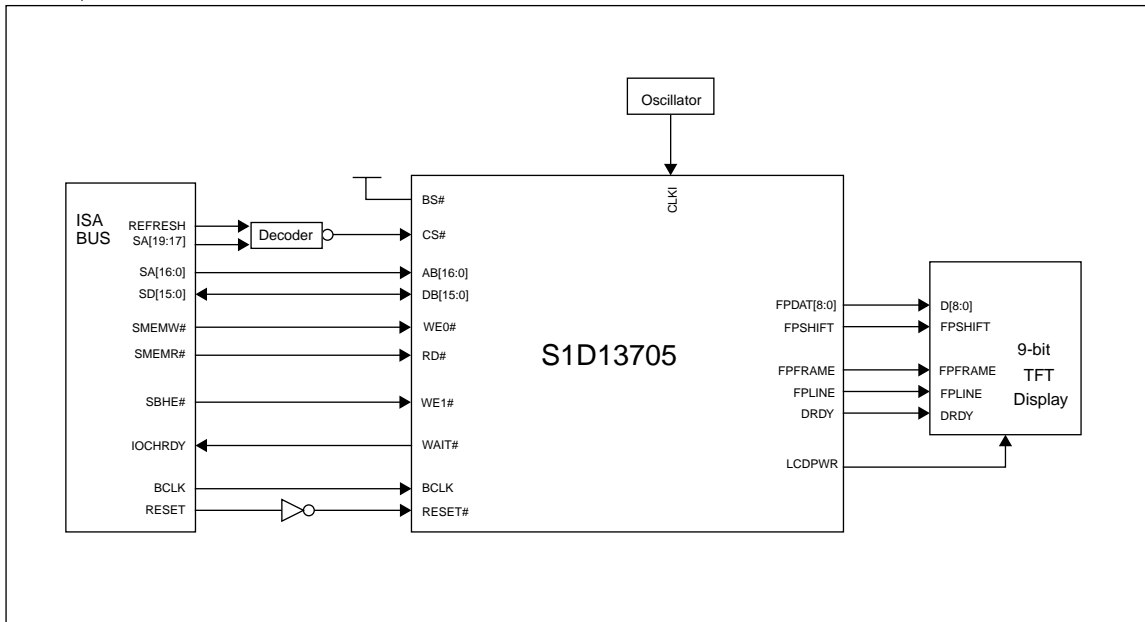

Figure 3-6 Typical System Diagram (Generic #2 Bus - e.g. ISA Bus)

4 FUNCTIONAL BLOCK DIAGRAM

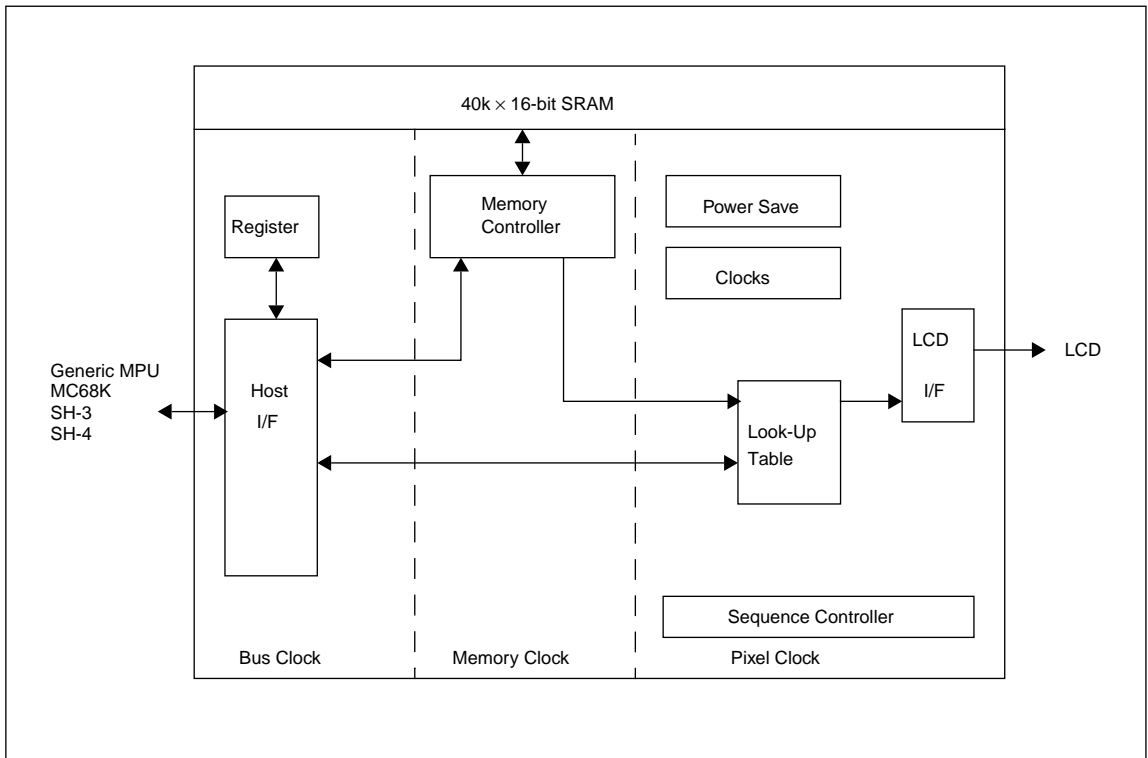

Figure 4-1 System Block Diagram Showing Data Paths

4.1 Functional Block Descriptions

4.1.1 Host Interface

The Host Interface provides the means for the CPU/MPU to communicate with the display buffer and internal registers.

4.1.2 Memory Controller

The Memory Controller arbitrates between CPU accesses and display refresh accesses. It also generates the necessary signals to control the SRAM frame buffer.

4.1.3 Sequence Controller

The Sequence Controller controls data flow from the Memory Controller through the Look-Up Table and to the LCD Interface. It also generates memory addresses for display refresh accesses.

4.1.4 Look-Up Table

The Look-Up Table contains three 256×4 Look-Up Tables or palettes, one for each primary color. In monochrome mode only the green Look-Up Table is used.

4.1.5 LCD Interface

The LCD Interface performs frame rate modulation for passive LCD panels. It also generates the correct data format and timing control signals for various LCD and TFT/D-TFD panels.

4.1.6 Power Save

Power Save contains the power save mode circuitry.

5 PINS

5.1 Pinout Diagram

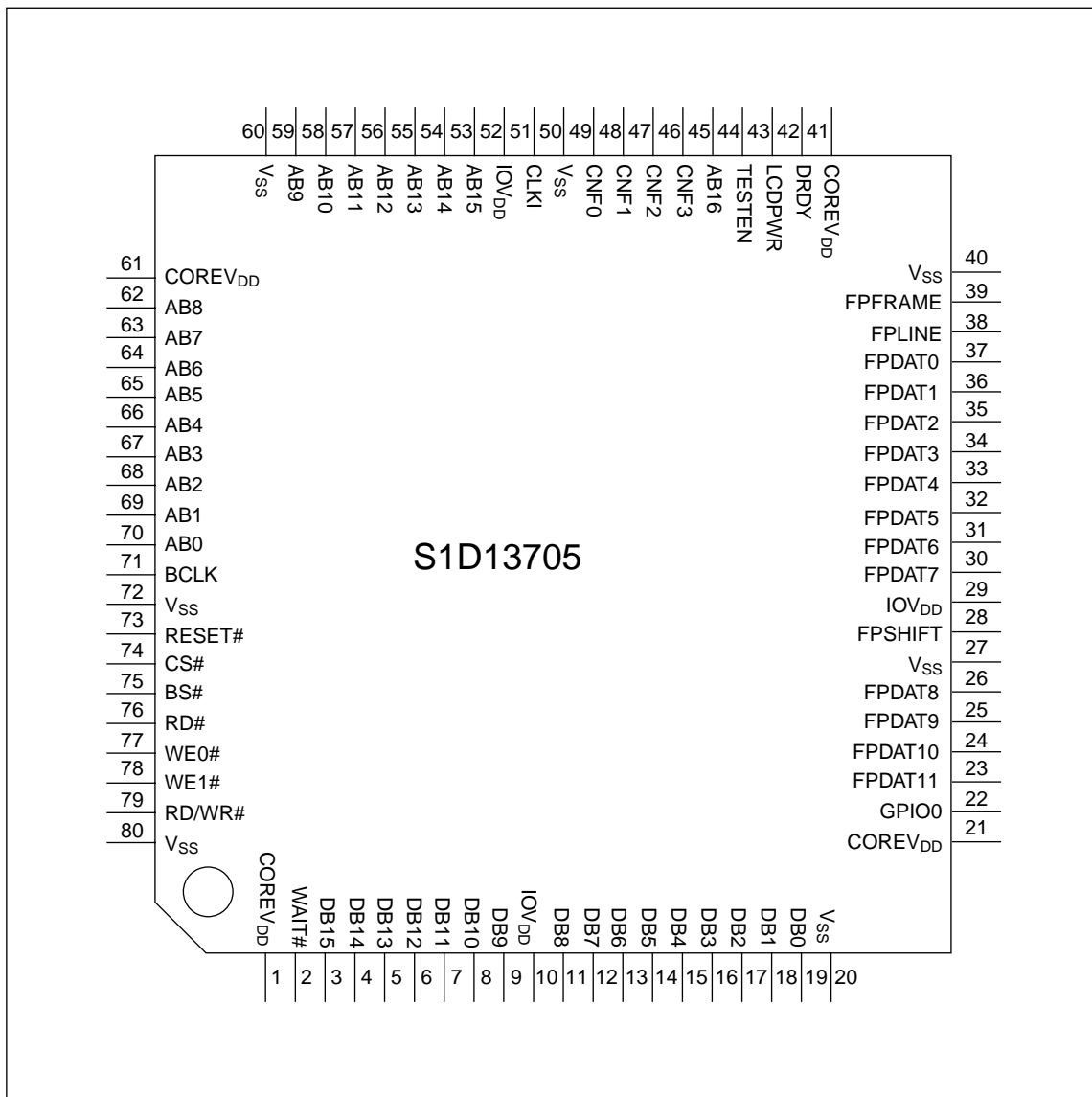

Figure 5-1 Pinout Diagram

Note: Package type: 80 pin surface mount QFP14

5.2 Pin Description

Key:

I	=	Input
O	=	Output
IO	=	Bi-Directional (Input/Output)
P	=	Power pin
C	=	CMOS level input
CS	=	CMOS level Schmitt input
COx	=	CMOS output driver, x denotes driver type (see I _{OL} /I _{OH} in Table 6-4: “Output Specifications,” on page 1-16)
TSx	=	Tri-state CMOS output driver, x denotes driver type (see I _{OL} /I _{OH} in Table 6-4: “Output Specifications,” on page 1-16)
CNx	=	CMOS low-noise output driver, x denotes driver type (see I _{OL} /I _{OH} in Table 6-4: “Output Specifications,” on page 1-16)
TEST	=	CMOS level test input with pull down resistor

5.2.1 Host Interface

Table 5-1 Host Interface Pin Descriptions

Pin Names	Type	Pin #	Cell	RESET# State	Description
AB0	I	70	CS	Input	This pin has multiple functions. <ul style="list-style-type: none"> For SH-3/SH-4 mode, this pin inputs system address bit 0 (A0). For MC68K #1, this pin inputs the lower data strobe (LDS#). For MC68K #2, this pin inputs system address bit 0 (A0). For Generic #1, this pin inputs system address bit 0 (A0). For Generic #2, this pin inputs system address bit 0 (A0). See Table 5-7, “Host Bus Interface Pin Mapping,” on page 1-13 for summary.
AB[16:1]	I	45, 53, 54, 55, 56, 57, 58, 59, 62, 63, 64, 65, 66, 67, 68, 69	C	Input	These pins input the system address bits 16 through 1 (A[16:1]).
DB[15:0]	IO	3, 4, 5, 6, 7, 8, 9, 11, 12, 13, 14, 15, 16, 17, 18, 19	C/TS2	Hi-Z	These pins have multiple functions. <ul style="list-style-type: none"> For SH-3/SH-4 mode, these pins are connected to D[15:0]. For MC68K #1, these pins are connected to D[15:0]. For MC68K #2, these pins are connected to D[31:16] for a 32-bit device (e.g. MC68030) or D[15:0] for a 16-bit device (e.g. MC68340). For Generic #1, these pins are connected to D[15:0]. For Generic #2, these pins are connected to D[15:0]. See Table 5-7, “Host Bus Interface Pin Mapping,” on page 1-13 for summary.
WE0#	I	77	CS	Input	This pin has multiple functions. <ul style="list-style-type: none"> For SH-3/SH-4 mode, this pin inputs the write enable signal for the lower data byte (WE0#). For MC68K #1, this pin must be tied to IO V_{DD}. For MC68K #2, this pin inputs the bus size bit 0 (SIZ0). For Generic #1, this pin inputs the write enable signal for the lower data byte (WE0#). For Generic #2, this pin inputs the write enable signal (WE#) See Table 5-7, “Host Bus Interface Pin Mapping,” on page 1-13 for summary.

Table 5-1 Host Interface Pin Descriptions

Pin Names	Type	Pin #	Cell	RESET# State	Description
WE1#	I	78	CS	Input	<p>This pin has multiple functions.</p> <ul style="list-style-type: none"> For SH-3/SH-4 mode, this pin inputs the write enable signal for the upper data byte (WE1#). For MC68K #1, this pin inputs the upper data strobe (UDS#). For MC68K #2, this pin inputs the data strobe (DS#). For Generic #1, this pin inputs the write enable signal for the upper data byte (WE1#). For Generic #2, this pin inputs the byte enable signal for the high data byte (BHE#). <p>See Table 5-7, "Host Bus Interface Pin Mapping," on page 1-13 for summary.</p>
CS#	I	74	C	Input	This pin inputs the chip select signal.
BCLK	I	71	C	Input	This pin inputs the system bus clock.
BS#	I	75	CS	Input	<p>This pin has multiple functions.</p> <ul style="list-style-type: none"> For SH-3/SH-4 mode, this pin inputs the bus start signal (BS#). For MC68K #1, this pin inputs the address strobe (AS#). For MC68K #2, this pin inputs the address strobe (AS#). For Generic #1, this pin must be tied to V_{SS}. For Generic #2, this pin must be tied to IO V_{DD}. <p>See Table 5-7, "Host Bus Interface Pin Mapping," on page 1-13 for summary.</p>
RD/WR#	I	79	CS	Input	<p>This pin has multiple functions.</p> <ul style="list-style-type: none"> For SH-3/SH-4 mode, this pin inputs the RD/WR# signal. The S1D13705 needs this signal for early decode of the bus cycle. For MC68K #1, this pin inputs the R/W# signal. For MC68K #2, this pin inputs the R/W# signal. For Generic #1, this pin inputs the read command for the upper data byte (RD1#). For Generic #2, this pin must be tied to IO V_{DD}. <p>See Table 5-7, "Host Bus Interface Pin Mapping," on page 1-13 for summary.</p>
RD#	I	76	CS	Input	<p>This pin has multiple functions.</p> <ul style="list-style-type: none"> For SH-3/SH-4 mode, this pin inputs the read signal (RD#). For MC68K #1, this pin must be tied to IO V_{DD}. For MC68K #2, this pin inputs the bus size bit 1 (SIZ1). For Generic #1, this pin inputs the read command for the lower data byte (RD0#). For Generic #2, this pin inputs the read command (RD#). <p>See Table 5-7, "Host Bus Interface Pin Mapping," on page 1-13 for summary.</p>
WAIT#	O	2	TS2	Hi-Z	<p>This pin has multiple functions.</p> <ul style="list-style-type: none"> For SH-3 mode, this pin outputs the wait request signal (WAIT#). For SH-4 mode, this pin outputs the device ready signal (RDY#). For MC68K #1, this pin outputs the data transfer acknowledge signal (DTACK#). For MC68K #2, this pin outputs the data transfer and size acknowledge bit 1 (DSACK1#). For Generic #1, this pin outputs the wait signal (WAIT#). For Generic #2, this pin outputs the wait signal (WAIT#). <p>See Table 5-7, "Host Bus Interface Pin Mapping," on page 1-13 for summary.</p>
RESET#	I	73	CS	0	Active low input to set all internal registers to the default state and to force all signals to their inactive states.

5.2.2 LCD Interface

Table 5-2 LCD Interface Pin Descriptions

Pin Name	Type	Pin #	Cell	RESET# State	Description
FPDAT[7:0]	O	30, 31, 32, 33, 34, 35, 36, 37	CN3	0	Panel Data
FPDAT[10:8]	O, IO	24, 25, 26	CN3	Input	These pins have multiple functions. <ul style="list-style-type: none"> Panel Data bits [10:8] for TFT/D-TFD panels. General Purpose Input/Output pins GPIO[3:1]. These pins should be connected to IO V _{DD} when unused. See Table 5-8, "LCD Interface Pin Mapping," on page 1-14 for summary.
FPDAT11	O, IO	23	CN3	Input	This pin has multiple functions. <ul style="list-style-type: none"> Panel Data bit 11 for TFT/D-TFD panels. General Purpose Input/Output pin GPIO4. Inverse Video select pin. This pin should be connected to IO V _{DD} when unused. See Table 5-8, "LCD Interface Pin Mapping," on page 1-14 for summary.
FPFRAME	O	39	CN3	0	Frame Pulse
FPLINE	O	38	CN3	0	Line Pulse
FPSHIFT	O	28	CN3	0	Shift Clock
LCDPWR	O	43	CO1	0	Active high LCD Power Control
DRDY	O	42	CN3	0	This pin has multiple functions. <ul style="list-style-type: none"> TFT/D-TFD Display Enable (DRDY). LCD Backplane Bias (MOD). Second Shift Clock (FPSHIFT2). See Table 5-8, "LCD Interface Pin Mapping," on page 1-14 for summary.

5.2.3 Clock Input

Table 5-3 Clock Input Pin Description

Pin Name	Type	Pin #	Driver	Description
CLKI	I	51	C	Input Clock

5.2.4 Miscellaneous

Table 5-4 Miscellaneous Pin Descriptions

Pin Name	Type	Pin #	Cell	RESET# State	Description
CNF[3:0]	I	46, 47, 48, 49	C	As set by hardware	These inputs are used to configure the S1D13705 - see Table 5-6, "Summary of Power On/Reset Options," on page 1-13. Must be connected directly to IO V _{DD} or V _{SS} .
GPIO0	IO, I	22	CS/TS1	Input	This pin has multiple functions - see REG[03h] bit 2. General Purpose Input/Output pin. Hardware Power Save.
TESTEN	I	44	TEST	Pulled low	Test Enable input. This input must be connected to V _{SS} .

5.2.5 Power Supply

Table 5-5 Power Supply Pin Descriptions

Pin Name	Type	Pin #	Driver	Description
COREV _{DD}	P	1, 21, 41, 61	P	Core V _{DD}
IOV _{DD}	P	10, 29, 52	P	IO V _{DD}
V _{SS}	P	20, 27, 40, 50, 60, 72, 80	P	Common V _{SS}

5.3 Summary of Configuration Options

Table 5-6 Summary of Power On/Reset Options

Configuration Pin	Power On/Reset State					
	1			0		
CNF3	Big Endian			Little Endian		
CNF[2:0]	Select host bus interface as follows:					
	CNF2	CNF1	CNF0	BS#	Host Bus	
	0	0	0	X	SH-4 interface	
	0	0	1	X	SH-3 interface	
	0	1	0	X	reserved	
	0	1	1	X	MC68K #1, 16-bit	
	1	0	0	X	reserved	
	1	0	1	X	MC68K #2, 16-bit	
	1	1	0	0	reserved	
	1	1	0	1	reserved	
	1	1	1	0	Generic #1, 16-bit	
	1	1	1	1	Generic #2, 16-bit	

5.4 Host Bus Interface Pin Mapping

Table 5-7 Host Bus Interface Pin Mapping

S1D13705 Pin Names	SH-3	SH-4	MC68K #1	MC68K #2	Generic #1	Generic #2
AB[16:1]	A[16:1]	A[16:1]	A[16:1]	A[16:1]	A[16:1]	A[16:1]
AB0	A0	A0	LDS#	A0	A0	A0
DB[15:0]	D[15:0]	D[15:0]	D[15:0]	D[31:16]	D[15:0]	D[15:0]
WE1#	WE1#	WE1#	UDS#	DS#	WE1#	BHE#
CS#	CSn#	CSn#	External Decode	External Decode	External Decode	External Decode
BCLK	CKIO	CKIO	CLK	CLK	BCLK	BCLK
BS#	BS#	BS#	AS#	AS#	connect to V _{SS}	connect to IO V _{DD}
RD/WR#	RD/WR#	RD/WR#	R/W#	R/W#	RD1#	connect to IO V _{DD}
RD#	RD#	RD#	connect to IO V _{DD}	SIZ1	RD0#	RD#
WE0#	WE0#	WE0#	connect to IO V _{DD}	SIZ0	WE0#	WE#
WAIT#	WAIT#	RDY#	DTACK#	DSACK1#	WAIT#	WAIT#
RESET#	RESET#	RESET#	RESET#	RESET#	RESET#	RESET#

5.5 LCD Interface Pin Mapping

Table 5-8 LCD Interface Pin Mapping

S1D13705 Pin Name	Monochrome Passive Panel			Color Passive Panel				Color TFT/D-TFD	
	4-bit Single	8-bit Single	8-bit Dual	4-bit Single	8-bit Single Format 1	8-bit Single Format 2	8-bit Dual	9-bit	12-bit
FPPFRAME	FPPFRAME								
FPLINE	FPLINE								
FPSHIFT	FPSHIFT								
DRDY	MOD	MOD	MOD	MOD	FPSHIFT2	MOD	MOD	DRDY	
FPDAT0	driven 0	D0	LD0	driven 0	D0	D0	LD0	R2	R3
FPDAT1	driven 0	D1	LD1	driven 0	D1	D1	LD1	R1	R2
FPDAT2	driven 0	D2	LD2	driven 0	D2	D2	LD2	R0	R1
FPDAT3	driven 0	D3	LD3	driven 0	D3	D3	LD3	G2	G3
FPDAT4	D0	D4	UD0	D0	D4	D4	UD0	G1	G2
FPDAT5	D1	D5	UD1	D1	D5	D5	UD1	G0	G1
FPDAT6	D2	D6	UD2	D2	D6	D6	UD2	B2	B3
FPDAT7	D3	D7	UD3	D3	D7	D7	UD3	B1	B2
FPDAT8	GPIO1	GPIO1	GPIO1	GPIO1	GPIO1	GPIO1	GPIO1	B0	B1
FPDAT9	GPIO2	GPIO2	GPIO2	GPIO2	GPIO2	GPIO2	GPIO2	GPIO2	R0
FPDAT10	GPIO3	GPIO3	GPIO3	GPIO3	GPIO3	GPIO3	GPIO3	GPIO3	G0
FPDAT11	GPIO4/ Hardware Video Invert	GPIO4/ Hardware Video Invert	GPIO4/ Hardware Video Invert	GPIO4/ Hardware Video Invert	GPIO4/ Hardware Video Invert	GPIO4/ Hardware Video Invert	GPIO4/ Hardware Video Invert	GPIO4	B0

Note: 1. Unused GPIO pins must be connected to IO V_{DD} .
2. Hardware Video Invert is enabled on FPDAT11 by REG[02h] bit 1.

6 D.C. CHARACTERISTICS

Table 6-1 Absolute Maximum Ratings

Symbol	Parameter	Rating	Units
Core V _{DD}	Supply Voltage	V _{SS} - 0.3 to 4.0	V
IO V _{DD}	Supply Voltage	Core V _{DD} to 7.0	V
V _{IN}	Input Voltage	V _{SS} - 0.3 to IO V _{DD} + 0.5	V
V _{OUT}	Output Voltage	V _{SS} - 0.3 to IO V _{DD} + 0.5	V
T _{STG}	Storage Temperature	-65 to 150	°C
T _{SOL}	Solder Temperature/Time	260 for 10 sec. Max. at lead	°C

Table 6-2 Recommended Operating Conditions for Core V_{DD} = 3.3V ± 10%

Symbol	Parameter	Condition	Min.	Typ.	Max.	Units
Core V _{DD}	Supply Voltage	V _{SS} = 0 V	2.7	3.0/3.3	3.6	V
IO V _{DD}	Supply Voltage	V _{SS} = 0 V, IO V _{DD} ≥ Core V _{DD}	2.7	3.0/3.3/5.0	5.5	V
V _{IN}	Input Voltage		V _{SS}		IO V _{DD}	V
T _{OPR}	Operating Temperature		-40	25	85	°C

Table 6-3 Input Specifications

Symbol	Parameter	Condition	Min.	Typ.	Max.	Units
V _{IL}	Low Level Input Voltage CMOS inputs	IO V _{DD} = 3.0			0.8	V
		3.3			0.8	V
		5.0			1.0	V
V _{IH}	High Level Input Voltage CMOS inputs	IO V _{DD} = 3.0	1.9			V
		3.3	2.0			V
		5.0	3.5			V
V _{T+}	Positive-going Threshold CMOS Schmitt inputs	IO V _{DD} = 3.0	1.0		2.3	V
		3.3	1.1		2.4	V
		5.0	2.0		4.0	V
V _{T-}	Negative-going Threshold CMOS Schmitt inputs	IO V _{DD} = 3.0	0.5		1.7	V
		3.3	0.6		1.8	V
		5.0	0.8		3.1	V
I _{IZ}	Input Leakage Current	V _{DD} = Max. V _{IH} = V _{DD} V _{IL} = V _{SS}	-1		1	μA
C _{IN}	Input Pin Capacitance				10	pF

6: D.C. CHARACTERISTICS

Table 6-4 Output Specifications

Symbol	Parameter	Condition	Min.	Typ.	Max.	Units
$I_{OL}(3.0V)$	Low Level Output Current	$IO V_{DD} = 3.0V$ $V_O = 0.4V$, Type = 1 2 3		1.8 5 10		mA
$I_{OL}(3.3V)$	Low Level Output Current	$IO V_{DD} = 3.3V$ $V_O = 0.4V$, Type = 1 2 3		2 6 12		mA
$I_{OL}(5.0V)$	Low Level Output Current	$IO V_{DD} = 5.0V$ $V_O = 0.4V$, Type = 1 2 3		3 8 12		mA
$I_{OH}(3.0V)$	High Level Output Current	$IO V_{DD} = 3.0V$ $V_O = IO V_{DD} - 0.4V$, Type = 1 2 3		-1.8 -5 -10		mA
$I_{OH}(3.3V)$	High Level Output Current	$IO V_{DD} = 3.3V$ $V_O = IO V_{DD} - 0.4V$, Type = 1 2 3		-2 -6 -12		mA
$I_{OH}(5.0V)$	High Level Output Current	$IO V_{DD} = 5.0V$ $V_O = IO V_{DD} - 0.4V$, Type = 1 2 3		-3 -8 -12		mA
V_{OL}	Low Level Output Voltage	$I = I_{OL}$			0.4	V
V_{OH}	High Level Output Voltage	$I = I_{OH}$	$IO V_{DD} - 0.4$			V
I_{OZ}	Output Leakage Current	$V_{DD} = \text{Max.}$ $V_{OH} = V_{DD}$ $V_{OL} = V_{SS}$	-1		1	μA
C_{OUT}	Output Pin Capacitance				10	pF
C_{BID}	Bidirectional Pin Capacitance				10	pF

7 A.C. CHARACTERISTICS

Conditions: IO $V_{DD} = 2.7\text{ V to }5.0\text{ V}$

$T_A = -40^\circ\text{C to }85^\circ\text{C}$

T_{rise} and T_{fall} for all inputs must be $\leq 5\text{ nsec}$ (10% ~ 90%)

$C_L = 60\text{ pF}$ (Bus/MPU Interface)

$C_L = 60\text{ pF}$ (LCD Panel Interface)

7.1 Bus Interface Timing

7.1.1 SH-4 Interface Timing

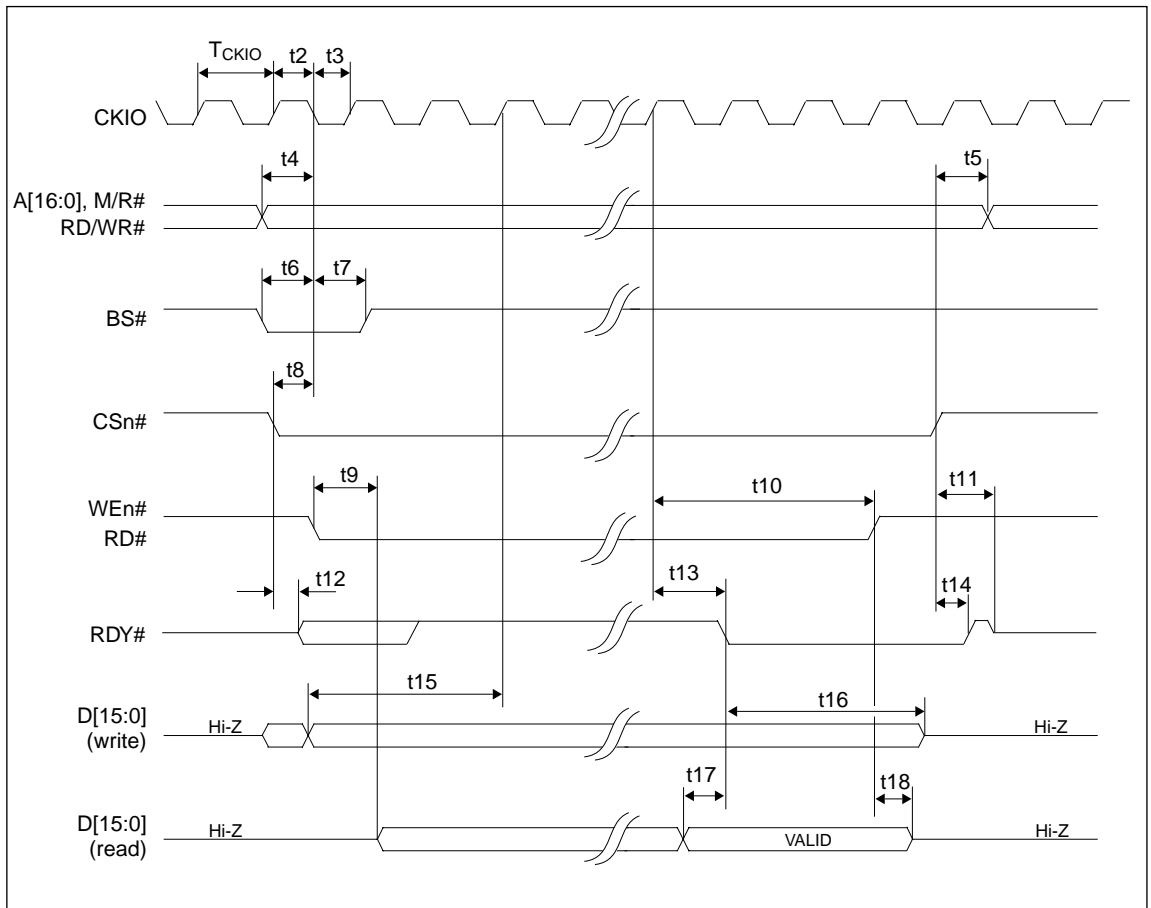

Figure 7-1 SH-4 Timing

Note: The SH-4 Wait State Control Register for the area in which the S1D13705 resides must be set to a non-zero value. The SH-4 read-to-write cycle transition must be set to a non-zero value (with reference to BUSCLK).

Table 7-1 SH-4 Timing

Symbol	Parameter	Min.	Max.	Units
f_{CKIO}	Bus Clock frequency		50	MHz
T_{CKIO}	Bus Clock period	$1/f_{CKIO}$		
t2	Bus Clock pulse width low	8		ns
t3	Bus Clock pulse width high	8		ns
t4	A[16:0], RD/WR# setup to CKIO	0		ns
t5	A[16:0], RD/WR# hold from CS#	0		ns
t6	BS# setup	5		ns
t7	BS# hold	5		ns
t8	CSn# setup	0		ns
t9	Falling edge RD# to DB[15:0] driven		25	ns
t10	CKIO to WE#, RD# high	$1.5 T_{CKIO}$		
t11	Rising edge CSn# to RDY# high impedance		T_{CKIO}	
t12	Falling edge CSn# to RDY# driven		20	ns
t13	CKIO to RDY# low		20	ns
t14	Rising edge CSn# to RDY# high		16	ns
t15	DB[15:0] setup to 2 nd CKIO after BS# (write cycle)	0		ns
t16	DB[15:0] hold (write cycle)	0		ns
t17	DB[15:0] valid to RDY# falling edge setup time (read cycle)	0		ns
t18	Rising edge RD# to DB[15:0] high impedance (read cycle)		10	ns

Note: CKIO may be turned off (held low) between accesses - see Section 13.5 "Turning Off BCLK Between Accesses" on page 1-70.

7.1.2 SH-3 Interface Timing

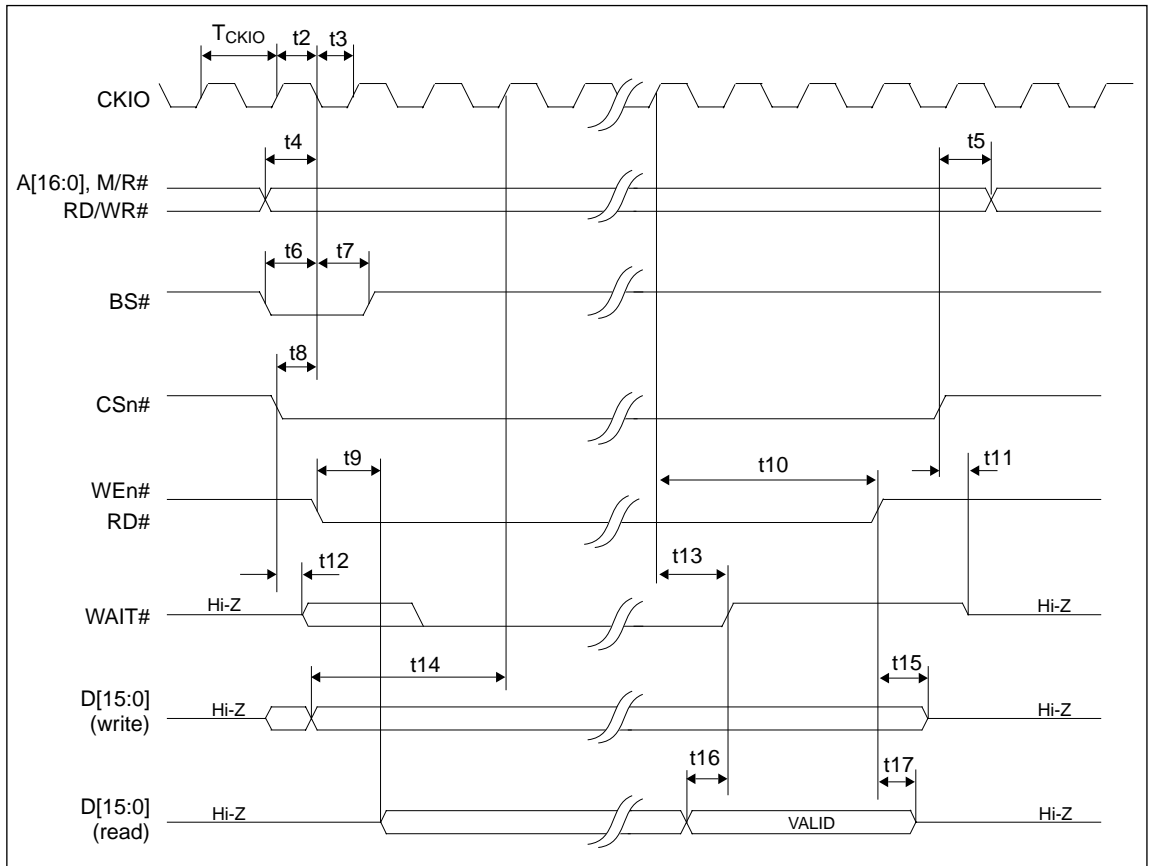

Figure 7-2 SH-3 Bus Timing

Note: The SH-3 Wait State Control Register for the area in which the S1D13705 resides must be set to a non-zero value.

Table 7-2 SH-3 Bus Timing

Symbol	Parameter	Min.	Max.	Units
f_{CKIO}	Bus Clock frequency		50	MHz
T_{CKIO}	Bus Clock period	$1/f_{CKIO}$		
t_2	Bus Clock pulse width low	8		ns
t_3	Bus Clock pulse width high	8		ns
t_4	A[16:0], RD/WR# setup to CKIO	0		ns
t_5	A[16:0], RD/WR# hold from CS#	0		ns
t_6	BS# setup	5		ns
t_7	BS# hold	5		ns
t_8	CSn# setup	0		ns
t_9	Falling edge RD# to DB[15:0] driven		25	ns
t_{10}	CKIO to WEn#, RD#high	$1.5 T_{CKIO}$		
t_{11}	Rising edge CSn# to WAIT# high impedance		10	ns
t_{12}	Falling edge CSn# to WAIT# driven		15	ns
t_{13}	CKIO to WAIT# delay		20	ns
t_{14}	DB[15:0] setup to 2 nd CKIO after BS# (write cycle)	0		ns
t_{15}	DB[15:0] hold from rising edge of WEn# (write cycle)	0		ns
t_{16}	DB[15:0] valid to WAIT# rising edge setup time (read cycle)	0		ns
t_{17}	Rising edge RD# to DB[15:0] high impedance (read cycle)		10	ns

Note: CKIO may be turned off (held low) between accesses - see Section 13.5 "Turning Off BCLK Between Accesses" on page 1-70.

7.1.3 Motorola MC68K #1 Interface Timing

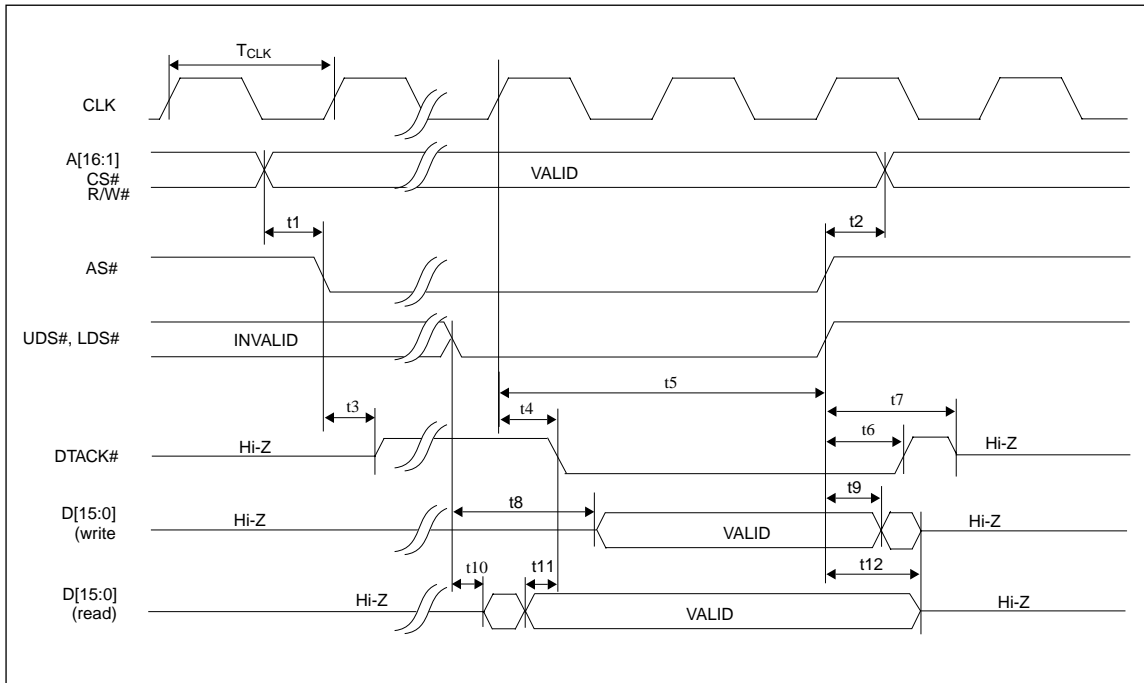

Figure 7-3 MC68K #1 Bus Timing (MC68000)

Table 7-3 MC68K #1 Bus Timing (MC68000)

Symbol	Parameter	Min.	Max.	Units
f_{CLK}	Bus Clock Frequency		33	MHz
T_{CLK}	Bus Clock period	$1/f_{CLK}$		
t1	A[16:1], CS# valid before AS# falling edge	0		ns
t2	A[16:1], CS# hold from AS# rising edge	0		ns
t3	AS# low to DTACK# driven high		16	ns
t4	CLK to DTACK# low		15	ns
t5	CLK to AS#, UDS#, LDS# high	$1 T_{CLK}$		
t6	AS# high to DTACK# high		20	ns
t7	AS# high to DTACK# high impedance		T_{CLK}	
t8	UDS#, LDS# falling edge to D[15:0] valid (write cycle)		T_{CLK}	
t9	D[15:0] hold from AS# rising edge (write cycle)	0		ns
t10	UDS#, LDS# falling edge to D[15:0] driven (read cycle)		15	ns
t11	D[15:0] valid to DTACK# falling edge (read cycle)	0		ns
t12	UDS#, LDS# rising edge to D[15:0] high impedance		10	ns

Note: CKIO may be turned off (held low) between accesses - see Section 13.5 “Turning Off BCLK Between Accesses” on page 1-70.

7.1.4 Motorola MC68K #2 Interface Timing

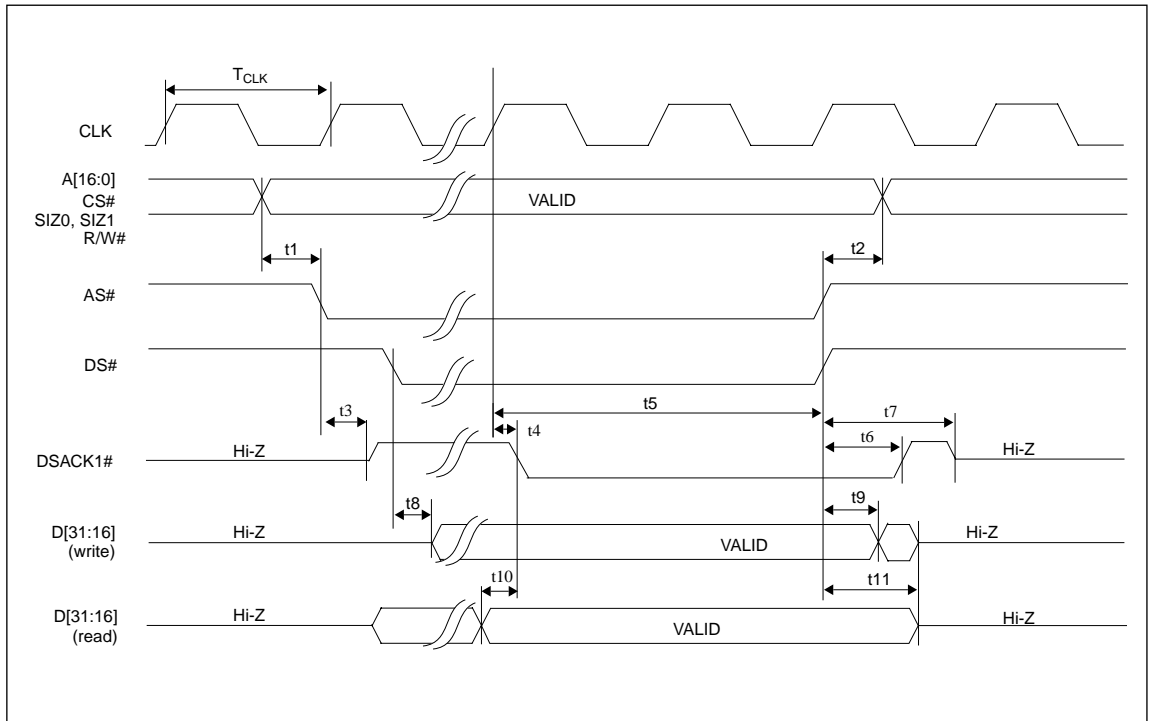

Figure 7-4 MC68K #2 Timing (MC68030)

Table 7-4 MC68K #2 Timing (MC68030)

Symbol	Parameter	Min.	Max.	Units
f_{CLK}	Bus Clock frequency		33	MHz
T_{CLK}	Bus Clock period	$1/f_{CLK}$		
$t1$	A[16:0], CS#, SIZ0, SIZ1 valid before AS# falling edge	0		ns
$t2$	A[16:0], CS#, SIZ0, SIZ1 hold from AS#, DS# rising edge	0		ns
$t3$	AS# low to DSACK1# driven high		22	ns
$t4$	CLK to DSACK1# low		18	ns
$t5$	CLK to AS#, DS# high	$1 T_{CLK}$		ns
$t6$	AS# high to DSACK1# high		20	ns
$t7$	AS# high to DSACK1# high impedance		T_{CLK}	
$t8$	DS# falling edge to D[31:16] valid (write cycle)		$T_{CLK}/2$	
$t9$	AS#, DS# rising edge to D[31:16] invalid (write cycle)	0		ns
$t10$	D[31:16] valid to DSACK1# low (read cycle)	0		ns
$t11$	AS#, DS# rising edge to D[31:16] high impedance		20	ns

Note: CKIO may be turned off (held low) between accesses - see Section 13.5 "Turning Off BCLK Between Accesses" on page 1-70.

7.1.5 Generic #1 Interface Timing

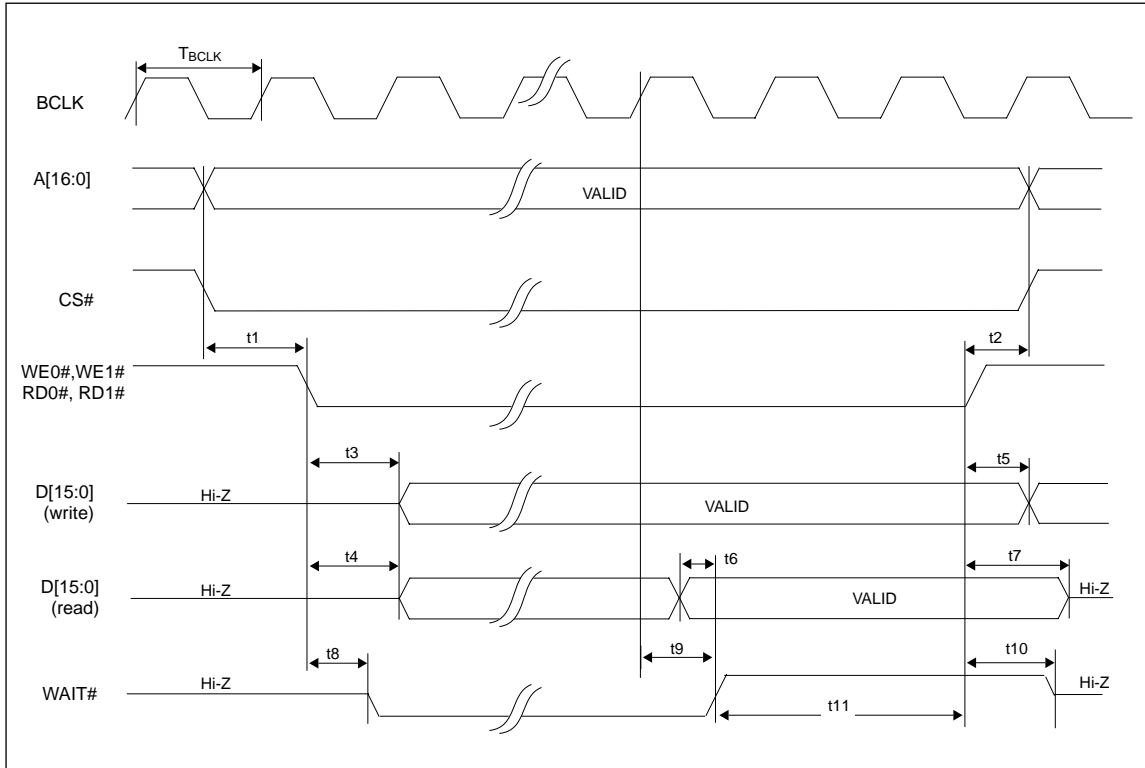

Figure 7-5 Generic #1 Timing

Table 7-5 Generic #1 Timing

Symbol	Parameter	Min.	Max.	Units
f_{BCLK}	Bus Clock frequency		50	MHz
T_{BCLK}	Bus Clock period	$1/f_{BCLK}$		MHz
t1	A[16:0], CS# valid to WE0#, WE1# low (write cycle) or RD0#, RD1# low (read cycle)	0		ns
t2	WE0#, WE1# high (write cycle) or RD0#, RD1# high (read cycle) to A[16:0], CS# invalid	0		ns
t3	WE0#, WE1# low to D[15:0] valid (write cycle)		T_{BCLK}	
t4	RD0#, RD1# low to D[15:0] driven (read cycle)		17	ns
t5	WE0#, WE1# high to D[15:0] invalid (write cycle)	0		ns
t6	D[15:0] valid to WAIT# high (read cycle)	0		ns
t7	RD0#, RD1# high to D[15:0] high impedance (read cycle)		10	ns
t8	WE0#, WE1# low (write cycle) or RD0#, RD1# low (read cycle) to WAIT# driven low		16	ns
t9	BCLK to WAIT# high		16	ns
t10	WE0#, WE1# high (write cycle) or RD0#, RD1# high (read cycle) to WAIT# high impedance		16	ns
t11	WAIT# high to WE0#, WE1#, RD0#, RD1# high	$1 T_{BCLK}$		

Note: CKIO may be turned off (held low) between accesses - see Section 13.5 “Turning Off BCLK Between Accesses” on page 1-70.

7.1.6 Generic #2 Interface Timing

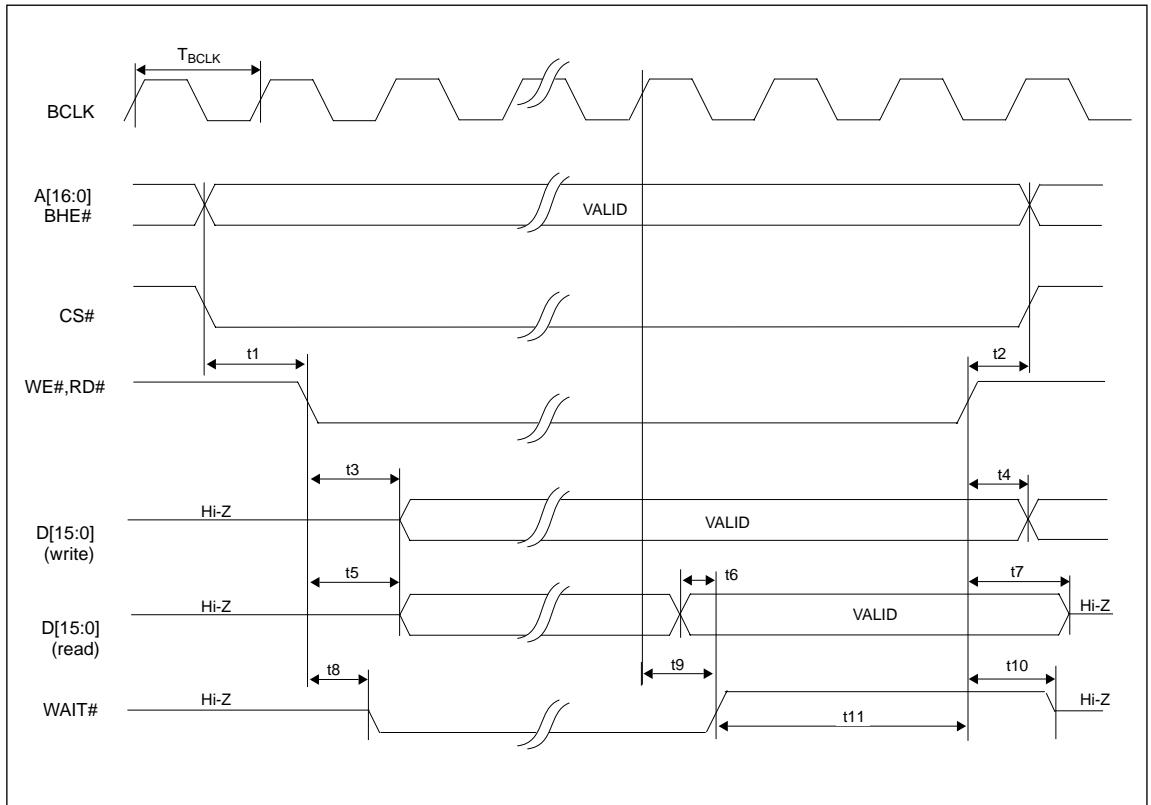

Figure 7-6 Generic #2 Timing

Table 7-6 Generic #2 Timing

Symbol	Parameter	Min.	Max.	Units
f_{BCLK}	Bus Clock frequency		50	MHz
T_{BCLK}	Bus Clock period	$1/f_{BCLK}$		
t_1	A[16:0], BHE#, CS# valid to WE#, RD# low	0		ns
t_2	WE#, RD# high to A[16:0], BHE#, CS# invalid	0		ns
t_3	WE# low to D[15:0] valid (write cycle)		T_{BCLK}	
t_4	WE# high to D[15:0] invalid (write cycle)	0		ns
t_5	RD# low to D[15:0] driven (read cycle)		16	ns
t_6	D[15:0] valid to WAIT# high (read cycle)	0		ns
t_7	RD# high to D[15:0] high impedance (read cycle)		10	ns
t_8	WE#, RD# low to WAIT# driven low		14	ns
t_9	BCLK to WAIT# high		10	ns
t_{10}	WE#, RD# high to WAIT# high impedance		11	ns
t_{11}	WAIT# high to WE#, RD# high	$1 T_{BCLK}$		

Note: CKIO may be turned off (held low) between accesses - see Section 13.5 "Turning Off BCLK Between Accesses" on page 1-70.

7.2 Clock Input Requirements

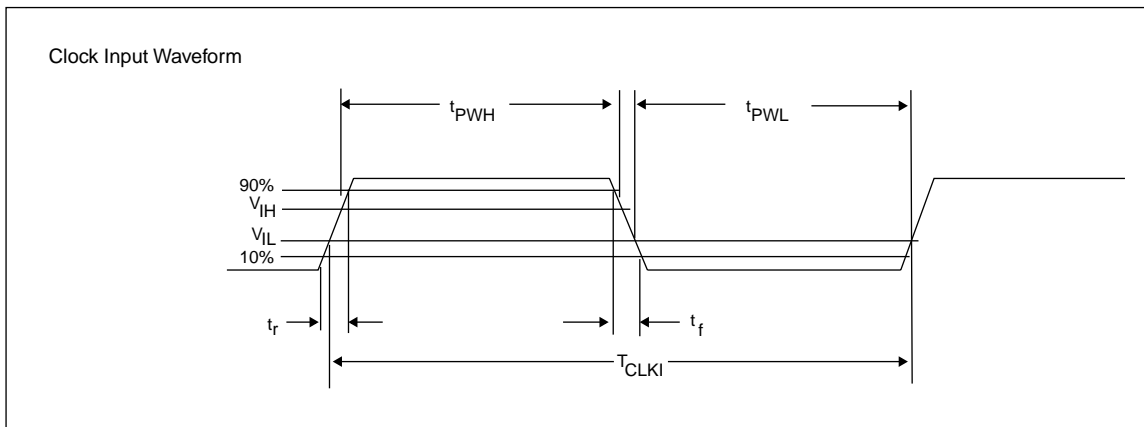

Figure 7-7 Clock Input Requirements

Table 7-7 Clock Input Requirements

Symbol	Parameter	Min.	Max.	Units
f_{CLKI}	Input Clock Frequency (CLKI)	0	50	MHz
T_{CLKI}	Input Clock period (CLKI)	$1/f_{CLKI}$		
t_{PWH}	Input Clock Pulse Width High (CLKI)	8		ns
t_{PWL}	Input Clock Pulse Width Low (CLKI)	8		ns
t_f	Input Clock Fall Time (10% - 90%)		5	ns
t_r	Input Clock Rise Time (10% - 90%)		5	ns

Note: When CLKI is > 25MHz it must be divided by 2 (REG[02h] bit 4 = 1).

7.3 Display Interface

7.3.1 Power On/Reset Timing

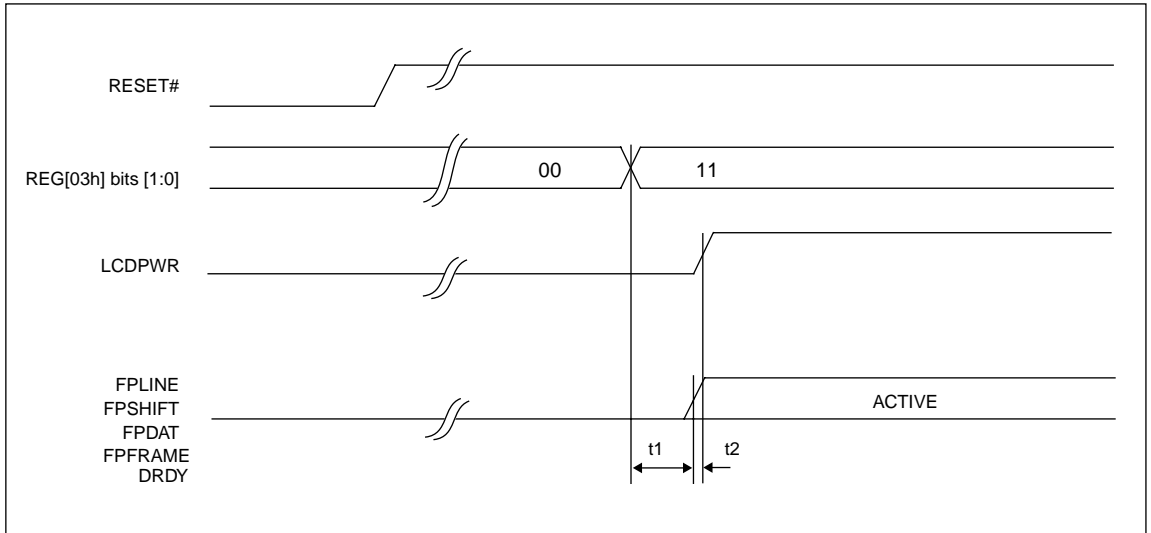

Figure 7-8 LCD Panel Power On/Reset Timing

Table 7-8 LCD Panel Power On/Reset Timing

Symbol	Parameter	Min.	Typ.	Max.	Units
t1	REG[03h] to FPLINE, FPFRAME, FPSHIFT, FPDAT, DRDY active			$T_{FPFRAME}$	ns
t2	FPLINE, FPFRAME, FPSHIFT, FPDAT, DRDY active to LCDPWR		0		Frames

Note: Where $T_{FPFRAME}$ is the period of FPFRAME and T_{PCLK} is the period of the pixel clock.

7.3.2 Power Down/Up Timing

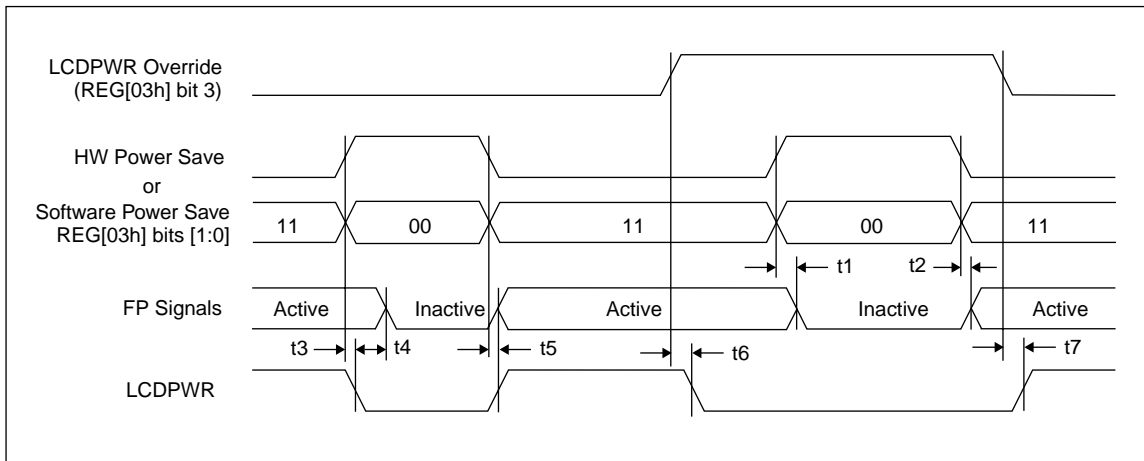

Figure 7-9 Power Down/Up Timing

Table 7-9 Power Down/Up Timing

Symbol	Parameter	Min.	Typ.	Max.	Units
t1	HW Power Save active to FPLINE, FPFRAME, FPSHIFT, FPDAT, DRDY inactive - LCDPWR Override = 1			1	Frame
t2	HW Power Save inactive to FPLINE, FPFRAME, FPSHIFT, FPDAT, DRDY active - LCDPWR Override = 1			1	Frame
t3	HW Power Save active to FPLINE, FPFRAME, FPSHIFT, FPDAT, DRDY inactive - LCDPWR Override = 0			1	Frame
t4	LCDPWR low to FPLINE, FPFRAME, FPSHIFT, FPDAT, DRDY inactive - LCDPWR Override = 0		127		Frame
t5	HW Power Save inactive to FPLINE, FPFRAME, FPSHIFT, FPDAT, DRDY, LCDPWR active - LCDPWR Override = 0		0		Frame
t6	LCDPWR Override active (1) to LCDPWR inactive			1	Frame
t7	LCDPWR Override inactive (1) to LCDPWR active			1	Frame

7.3.3 4-Bit Single Monochrome Panel Timing

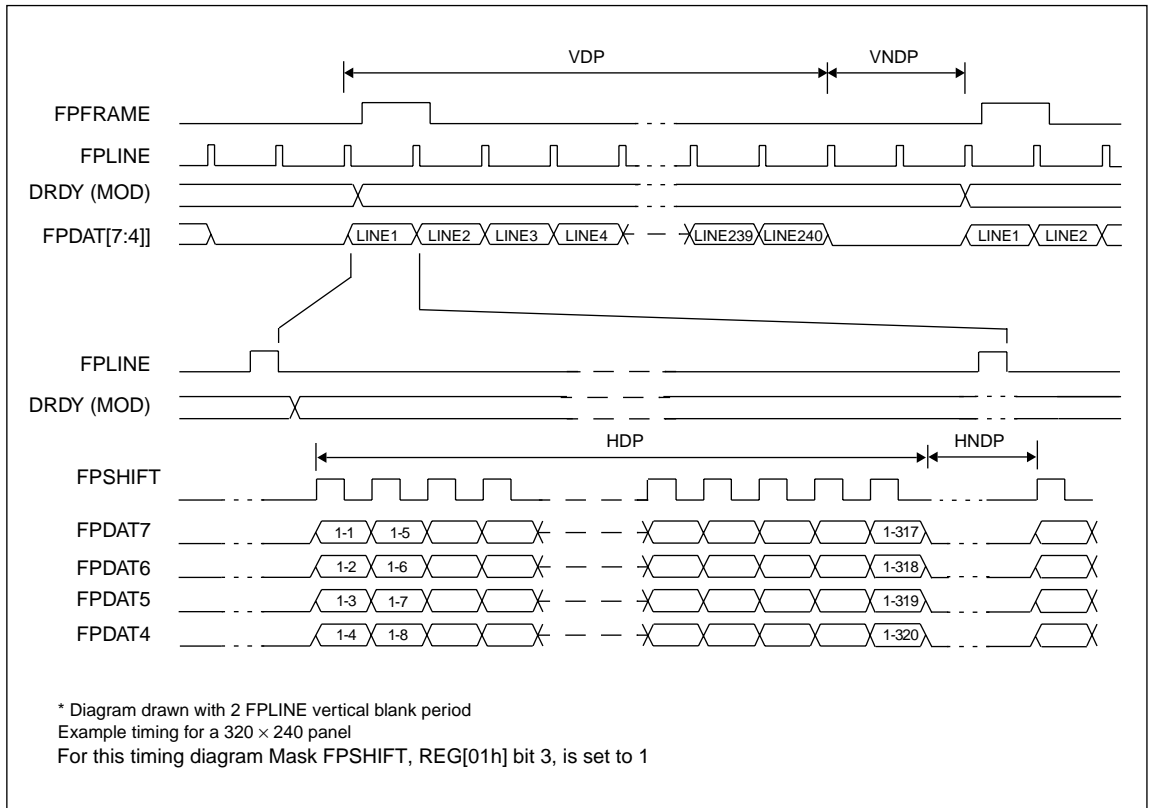

Figure 7-10 4-Bit Single Monochrome Panel Timing

- VDP = Vertical Display Period = (REG[06h] bits 1-0, REG[05h] bits 7-0) + 1 Lines
- VNDP = Vertical Non-Display Period = REG[0Ah] bits 5-0 Lines
- HDP = Horizontal Display Period = ((REG[04h] bits 6-0) + 1) × 8Ts
- HNDP = Horizontal Non-Display Period = (REG[08h] + 4) × 8Ts

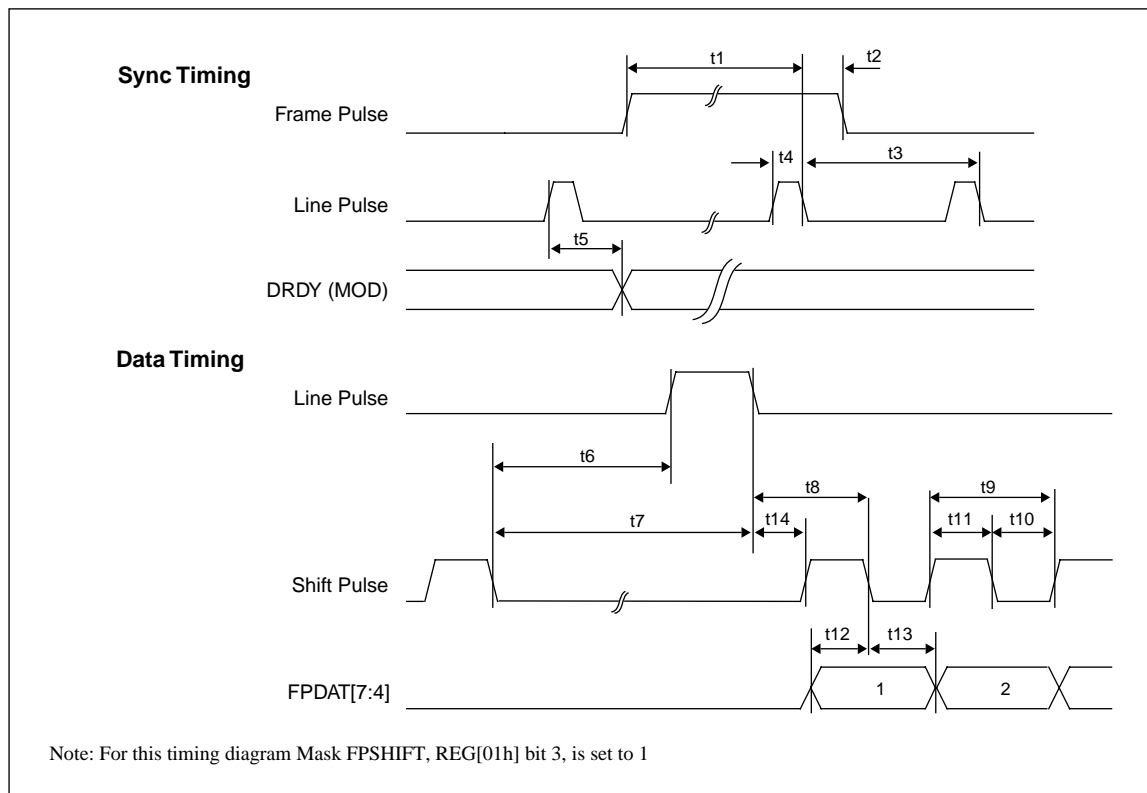

Figure 7-11 4-Bit Single Monochrome Panel A.C. Timing

Table 7-10 4-Bit Single Monochrome Panel A.C. Timing

Symbol	Parameter	Min.	Typ.	Max.	Units
t1	Frame Pulse setup to Line Pulse falling edge	note 2			(note 1)
t2	Frame Pulse hold from Line Pulse falling edge	9			Ts
t3	Line Pulse period	note 3			
t4	Line Pulse pulse width	9			Ts
t5	MOD delay from Line Pulse rising edge	1			Ts
t6	Shift Pulse falling edge to Line Pulse rising edge	note 4			
t7	Shift Pulse falling edge to Line Pulse falling edge	note 5			
t8	Line Pulse falling edge to Shift Pulse falling edge	$t_{14} + 2$			Ts
t9	Shift Pulse period	4			Ts
t10	Shift Pulse pulse width low	2			Ts
t11	Shift Pulse pulse width high	2			Ts
t12	FPDAT[7:4] setup to Shift Pulse falling edge	2			Ts
t13	FPDAT[7:4] hold to Shift Pulse falling edge	2			Ts
t14	Line Pulse falling edge to Shift Pulse rising edge	23			Ts

1. Ts = pixel clock period

2. $t_{1\min} = t_{3\min} - 9Ts$

3. $t_{3\min} = [((REG[04h] \text{ bits } 6-0) + 1) \times 8 + ((REG[08h] \text{ bits } 4-0) + 4) \times 8]Ts$

4. $t_{6\min} = [(REG[08h] \text{ bits } 4-0) \times 8 + 2]Ts$

5. $t_{7\min} = [(REG[08h] \text{ bits } 4-0) \times 8 + 11]Ts$

7.3.4 8-Bit Single Monochrome Panel Timing

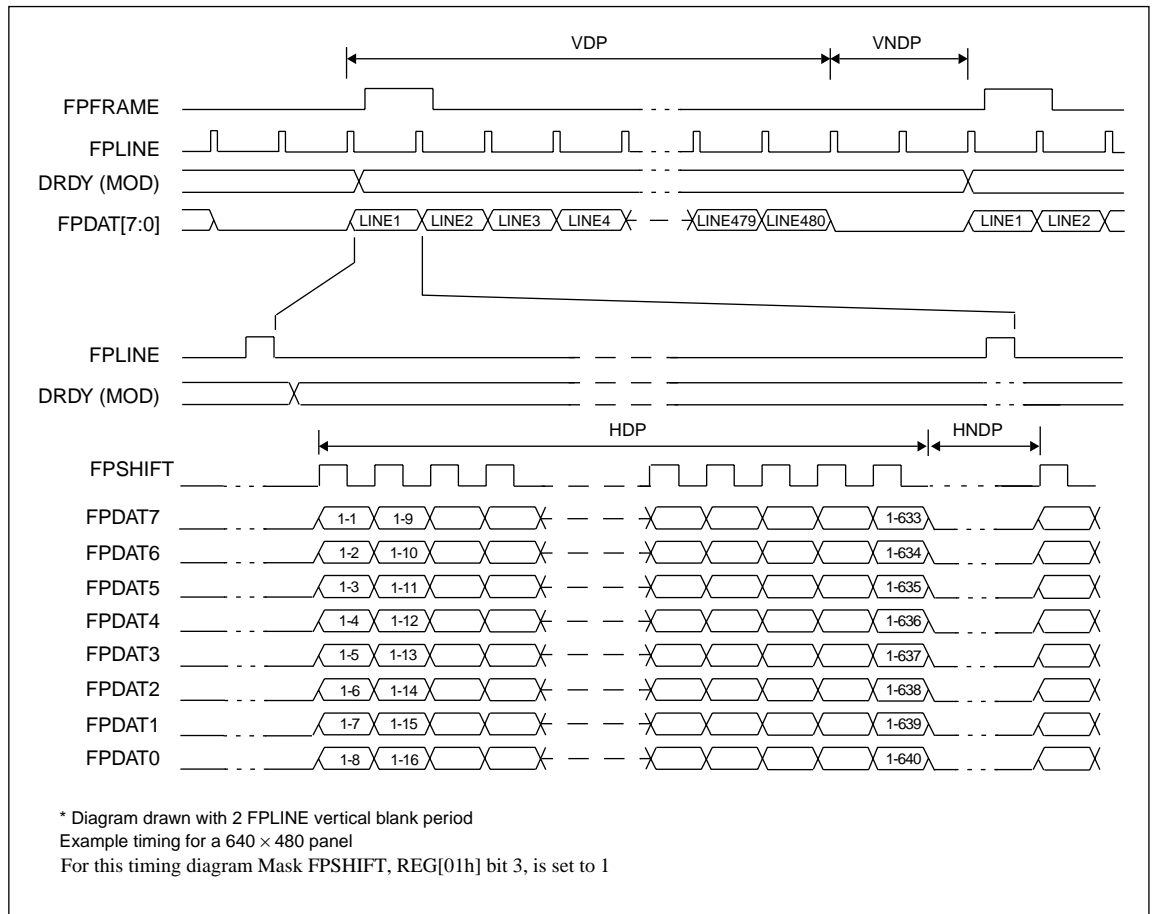

Figure 7-12 8-Bit Single Monochrome Panel Timing

VDP = Vertical Display Period = (REG[06h] bits 1-0, REG[05h] bits 7-0) + 1 Lines
 VNDP = Vertical Non-Display Period = REG[0Ah] bits 5-0 Lines
 HDP = Horizontal Display Period = ((REG[04h] bits 6-0) + 1) × 8Ts
 HNDP = Horizontal Non-Display Period = (REG[08h] + 4) × 8Ts

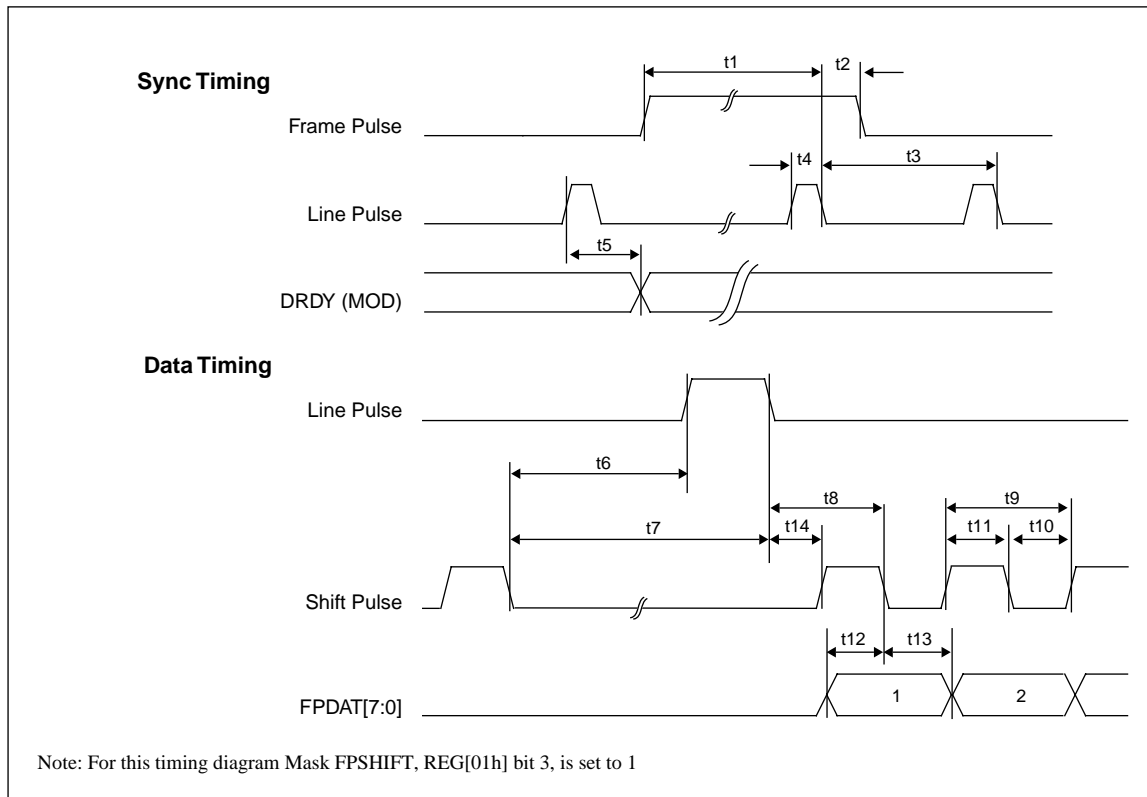

Figure 7-13 8-Bit Single Monochrome Panel A.C. Timing

Table 7-11 8-Bit Single Monochrome Panel A.C. Timing

Symbol	Parameter	Min.	Typ.	Max.	Units
t1	Frame Pulse setup to Line Pulse falling edge	note 2			(note 1)
t2	Frame Pulse hold from Line Pulse falling edge	9			Ts
t3	Line Pulse period	note 3			
t4	Line Pulse pulse width	9			Ts
t5	MOD delay from Line Pulse rising edge	1			Ts
t6	Shift Pulse falling edge to Line Pulse rising edge	note 4			
t7	Shift Pulse falling edge to Line Pulse falling edge	note 5			
t8	Line Pulse falling edge to Shift Pulse falling edge	$t_{14} + 4$			Ts
t9	Shift Pulse period	8			Ts
t10	Shift Pulse pulse width low	4			Ts
t11	Shift Pulse pulse width high	4			Ts
t12	FPDAT[7:0] setup to Shift Pulse falling edge	4			Ts
t13	FPDAT[7:0] hold to Shift Pulse falling edge	4			Ts
t14	Line Pulse falling edge to Shift Pulse rising edge	23			Ts

1. Ts = pixel clock period
2. $t_{1\min} = t_{3\min} - 9Ts$
3. $t_{3\min} = [((REG[04h] \text{ bits } 6-0)+1) \times 8 + ((REG[08h] \text{ bits } 4-0) + 4) \times 8]Ts$
4. $t_{6\min} = [(REG[08h] \text{ bits } 4-0) \times 8 + 4]Ts$
5. $t_{7\min} = [(REG[08h] \text{ bits } 4-0) \times 8 + 13]Ts$

7.3.5 4-Bit Single Color Panel Timing

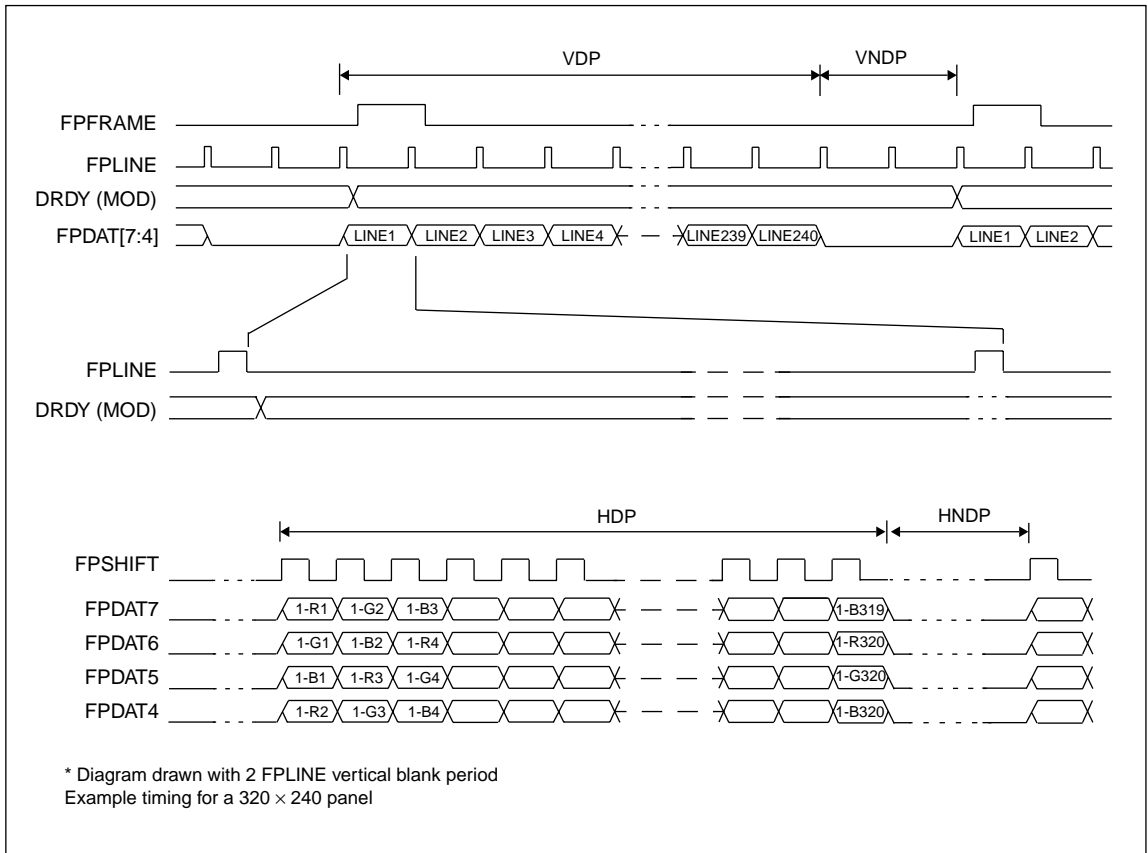

Figure 7-14 4-Bit Single Color Panel Timing

- VDP = Vertical Display Period = $(\text{REG}[06\text{h}] \text{ bits } 1-0, \text{REG}[05\text{h}] \text{ bits } 7-0) + 1$ Lines
 VNDP = Vertical Non-Display Period = $\text{REG}[0A\text{h}] \text{ bits } 5-0$ Lines
 HDP = Horizontal Display Period = $((\text{REG}[04\text{h}] \text{ bits } 6-0) + 1) \times 8T_s$
 HNDP = Horizontal Non-Display Period = $(\text{REG}[08\text{h}] + 4) \times 8T_s$

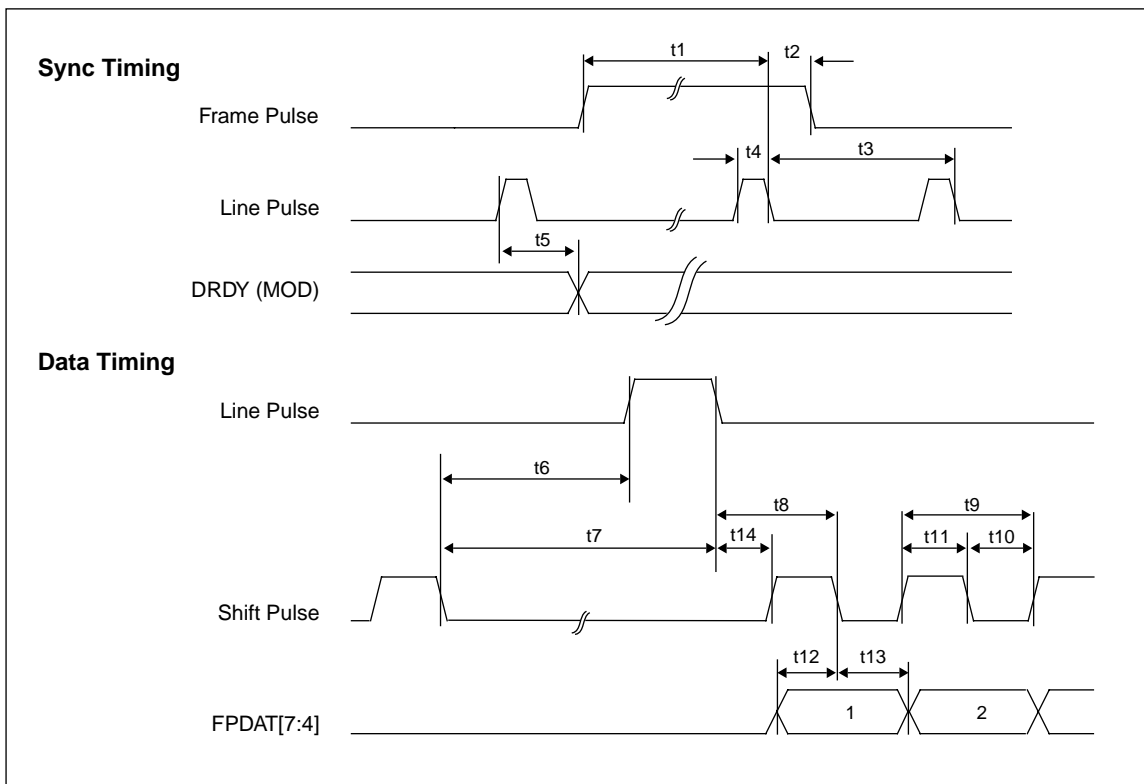

Figure 7-15 4-Bit Single Color Panel A.C. Timing

Table 7-12 4-Bit Single Color Panel A.C. Timing

Symbol	Parameter	Min.	Typ.	Max.	Units
t1	Frame Pulse setup to Line Pulse falling edge	note 2			(note 1)
t2	Frame Pulse hold from Line Pulse falling edge	9			Ts
t3	Line Pulse period	note 3			
t4	Line Pulse pulse width	9			Ts
t5	MOD delay from Line Pulse rising edge	1			Ts
t6	Shift Pulse falling edge to Line Pulse rising edge	note 4			
t7	Shift Pulse falling edge to Line Pulse falling edge	note 5			
t8	Line Pulse falling edge to Shift Pulse falling edge	t14 + 0.5			Ts
t9	Shift Pulse period	1			Ts
t10	Shift Pulse pulse width low	0.5			Ts
t11	Shift Pulse pulse width high	0.5			Ts
t12	FPDAT[7:4] setup to Shift Pulse falling edge	0.5			Ts
t13	FPDAT[7:4] hold to Shift Pulse falling edge	0.5			Ts
t14	Line Pulse falling edge to Shift Pulse rising edge	23			Ts

1. Ts = pixel clock period

2. t1_{min} = t3_{min} - 9Ts

3. t3_{min} = [((REG[04h] bits 6-0)+1) × 8 + ((REG[08h] bits 4-0) + 4) × 8]Ts

4. t6_{min} = [(REG[08h] bits 4-0) × 8 + 0.5]Ts

5. t7_{min} = [(REG[08h] bits 4-0) × 8 + 9.5]Ts

7.3.6 8-Bit Single Color Panel Timing (Format 1)

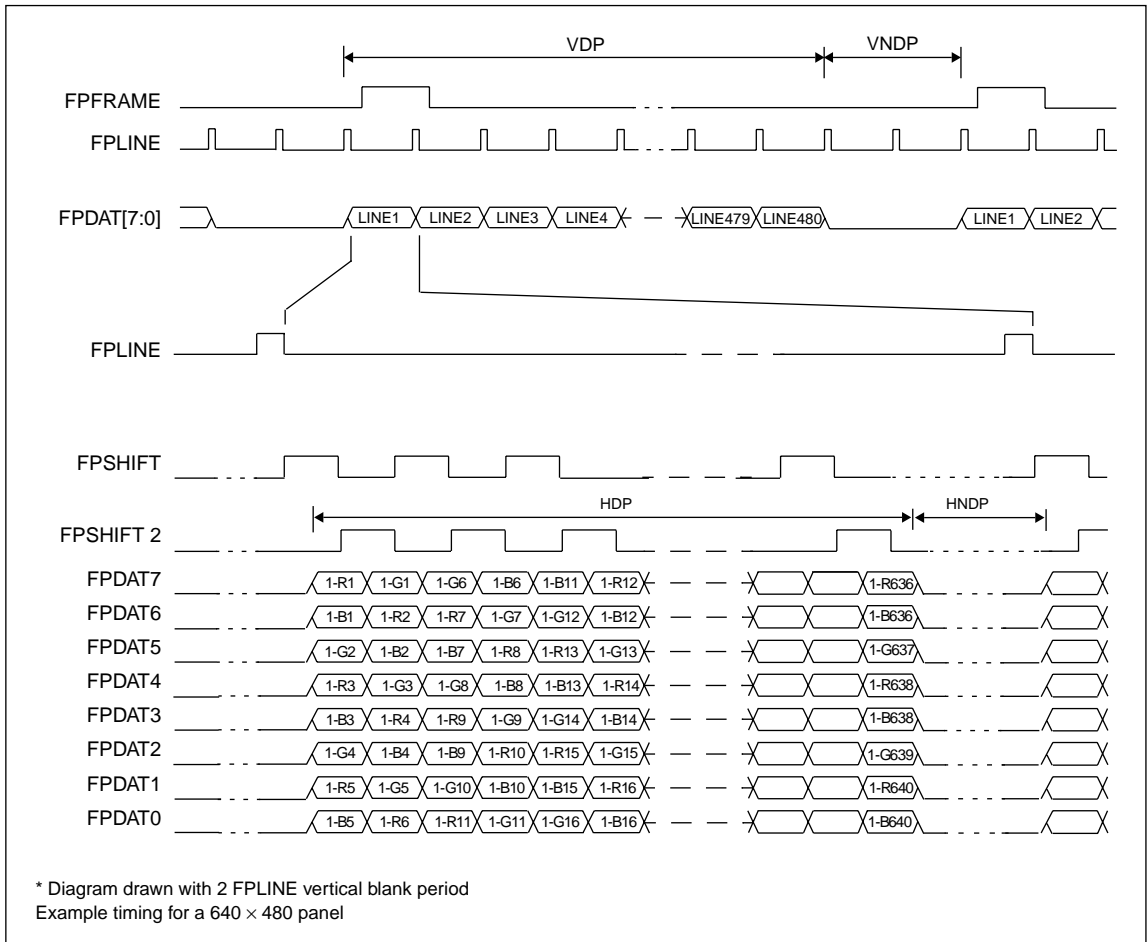

Figure 7-16 8-Bit Single Color Panel Timing (Format 1)

VDP = Vertical Display Period = (REG[06h] bits 1-0, REG[05h] bits 7-0) + 1 Lines
 VNDP = Vertical Non-Display Period = REG[0Ah] bits 5-0 Lines
 HDP = Horizontal Display Period = ((REG[04h] bits 6-0) + 1) × 8Ts
 HNDP = Horizontal Non-Display Period = (REG[08h] + 4) × 8Ts

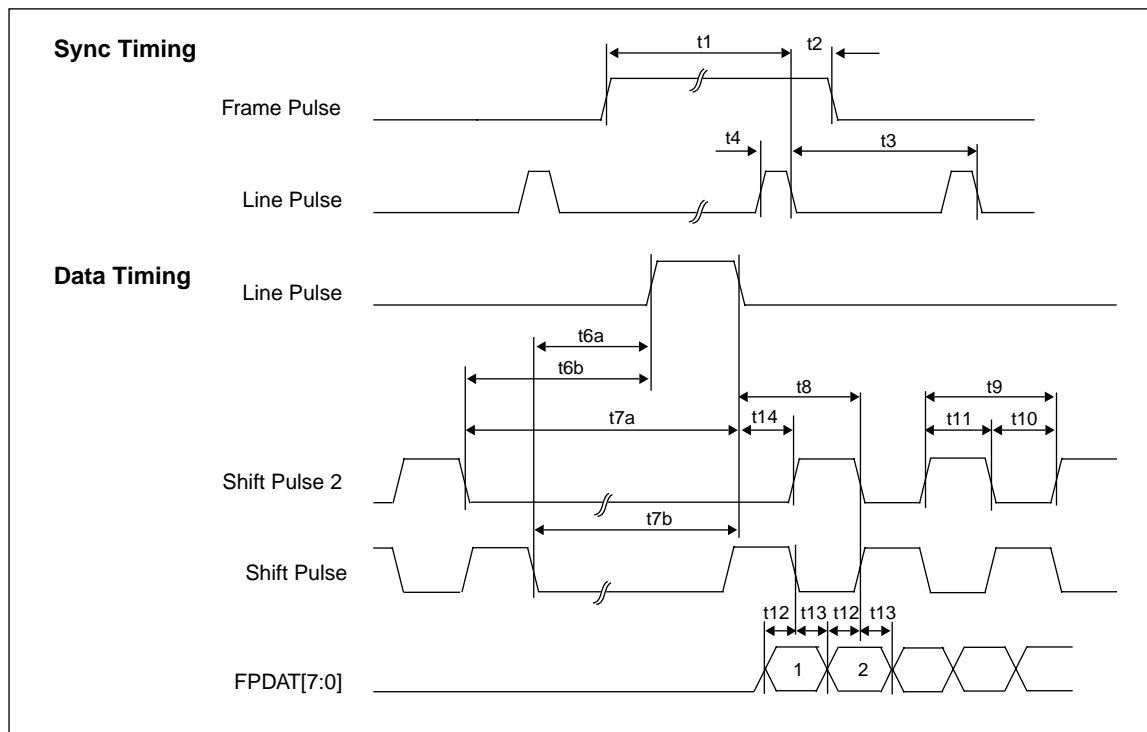

Figure 7-17 8-Bit Single Color Panel A.C. Timing (Format 1)

Table 7-13 8-Bit Single Color Panel A.C. Timing (Format 1)

Symbol	Parameter	Min.	Typ.	Max.	Units
t1	Frame Pulse setup to Line Pulse falling edge	note 2			(note 1)
t2	Frame Pulse hold from Line Pulse falling edge	9			Ts
t3	Line Pulse period	note 3			
t4	Line Pulse pulse width	9			Ts
t6a	Shift Pulse falling edge to Line Pulse rising edge	note 4			
t6b	Shift Pulse 2 falling edge to Line Pulse rising edge	note 5			
t7a	Shift Pulse 2 falling edge to Line Pulse falling edge	note 6			
t7b	Shift Pulse falling edge to Line Pulse falling edge	note 7			
t8	Line Pulse falling edge to Shift Pulse rising, Shift Pulse 2 falling edge	t14 + 2			Ts
t9	Shift Pulse 2, Shift Pulse period	4			Ts
t10	Shift Pulse 2, Shift Pulse pulse width low	2			Ts
t11	Shift Pulse 2, Shift Pulse pulse width high	2			Ts
t12	FPDAT[7:0] setup to Shift Pulse 2, Shift Pulse falling edge	1			Ts
t13	FPDAT[7:0] hold from Shift Pulse 2, Shift Pulse falling edge	1			Ts
t14	Line Pulse falling edge to Shift Pulse rising edge	23			Ts

1. Ts = pixel clock period
2. $t_{1min} = t_{3min} - 9Ts$
3. $t_{3min} = [((REG[04h] \text{ bits } 6-0)+1) \times 8 + ((REG[08h] \text{ bits } 4-0) + 4) \times 8]Ts$
4. $t_{6amin} = [(REG[08h] \text{ bits } 4-0) \times 8 + t_{13} - t_{10}]Ts$
5. $t_{6bmin} = [(REG[08h] \text{ bits } 4-0) \times 8 + t_{13}]Ts$
6. $t_{7amin} = [(REG[08h] \text{ bits } 4-0) \times 8 + 11]Ts$
7. $t_{7bmin} = [(REG[08h] \text{ bits } 4-0) \times 8 + 11] - t_{10}]Ts$

7.3.7 8-Bit Single Color Panel Timing (Format 2)

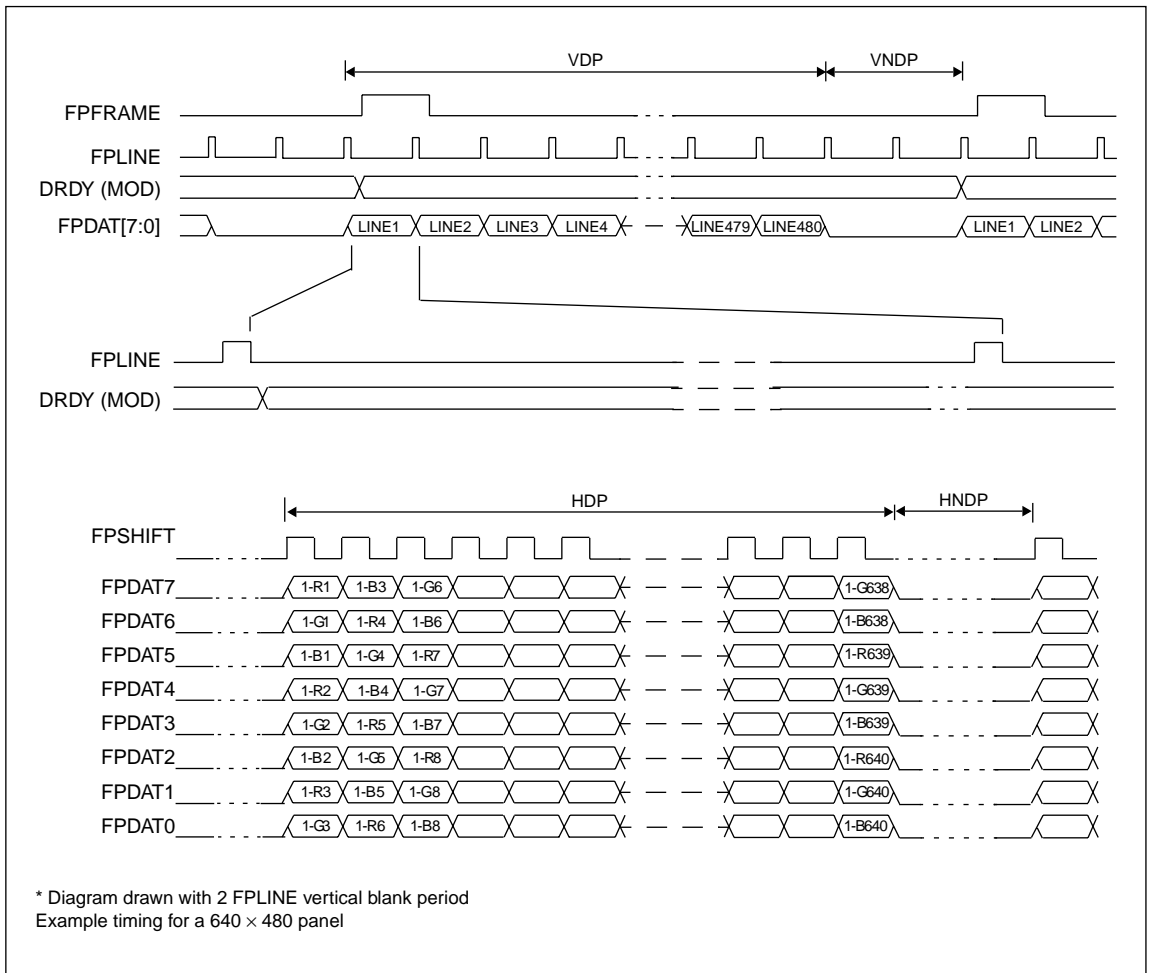

Figure 7-18 8-Bit Single Color Panel Timing (Format 2)

$VDP = \text{Vertical Display Period} = (\text{REG}[06\text{h}] \text{ bits } 1-0, \text{REG}[05\text{h}] \text{ bits } 7-0) + 1 \text{ Lines}$
 $VNDP = \text{Vertical Non-Display Period} = \text{REG}[0A\text{h}] \text{ bits } 5-0 \text{ Lines}$
 $HDP = \text{Horizontal Display Period} = ((\text{REG}[04\text{h}] \text{ bits } 6-0) + 1) \times 8T_s$
 $HNDP = \text{Horizontal Non-Display Period} = (\text{REG}[08\text{h}] + 4) \times 8T_s$

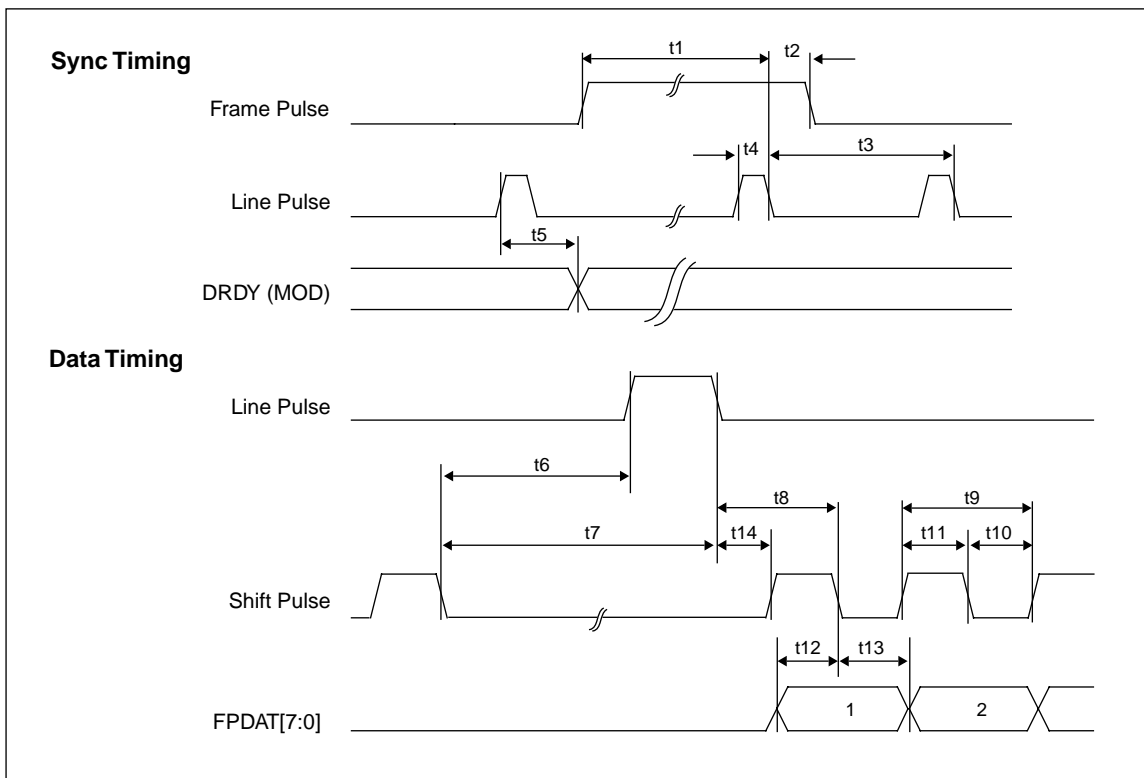

Figure 7-19 8-Bit Single Color Panel A.C. Timing (Format 2)

Table 7-14 8-Bit Single Color Panel A.C. Timing (Format 2)

Symbol	Parameter	Min.	Typ.	Max.	Units
t1	Frame Pulse setup to Line Pulse falling edge	note 2			(note 1)
t2	Frame Pulse hold from Line Pulse falling edge	9			Ts
t3	Line Pulse period	note 3			
t4	Line Pulse pulse width	9			Ts
t5	MOD delay from Line Pulse rising edge	1			Ts
t6	Shift Pulse falling edge to Line Pulse rising edge	note 4			
t7	Shift Pulse falling edge to Line Pulse falling edge	note 5			
t8	Line Pulse falling edge to Shift Pulse falling edge	t14 + 2			Ts
t9	Shift Pulse period	2			Ts
t10	Shift Pulse pulse width low	1			Ts
t11	Shift Pulse pulse width high	1			Ts
t12	FPDAT[7:0] setup to Shift Pulse falling edge	1			Ts
t13	FPDAT[7:0] hold to Shift Pulse falling edge	1			Ts
t14	Line Pulse falling edge to Shift Pulse rising edge	23			Ts

1. Ts = pixel clock period
2. t1_{min} = t3_{min} - 9Ts
3. t3_{min} = [((REG[04h] bits 6-0)+1) × 8 + ((REG[08h] bits 4-0) + 4) × 8]Ts
4. t6_{min} = [(REG[08h] bits 4-0) × 8 + 1]Ts
5. t7_{min} = [(REG[08h] bits 4-0) × 8 + 10]Ts

7.3.8 8-Bit Dual Monochrome Panel Timing

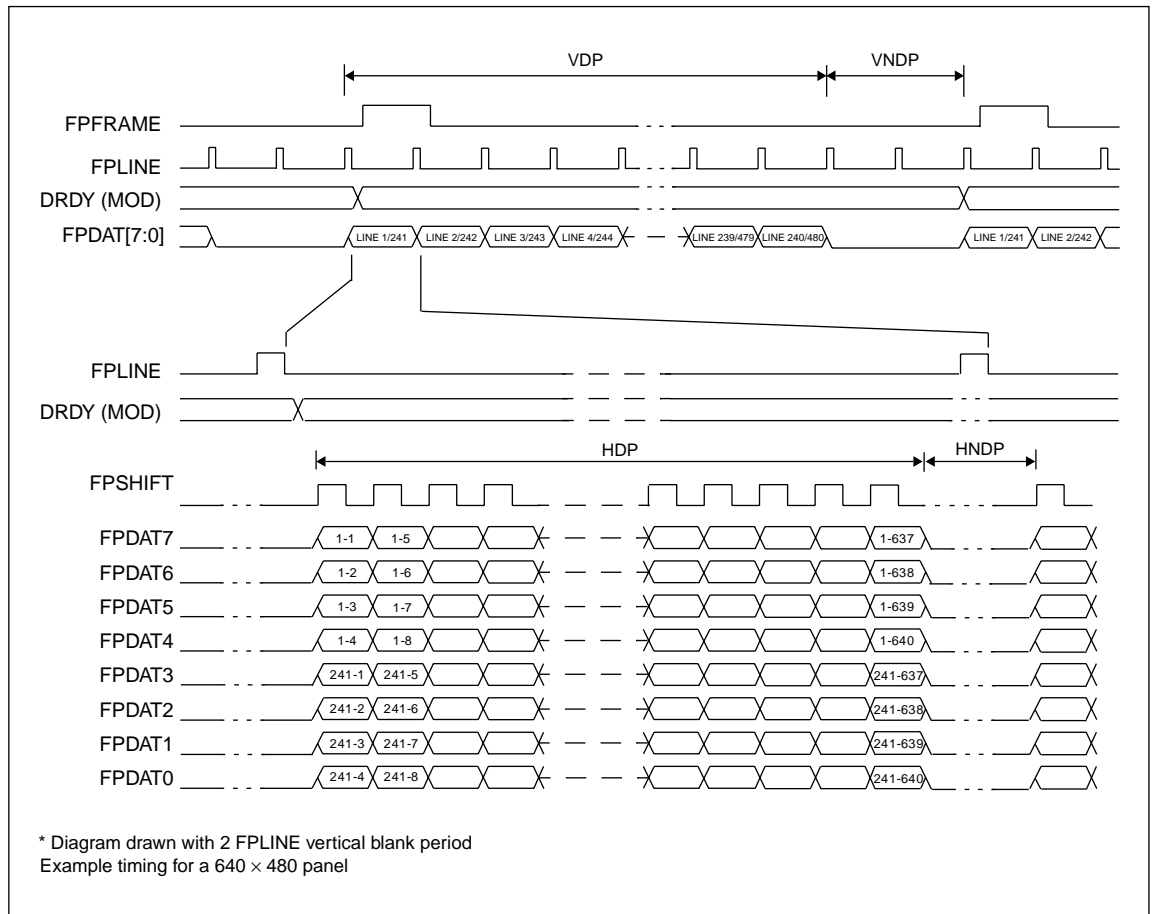

Figure 7-20 8-Bit Dual Monochrome Panel Timing

$VDP = \text{Vertical Display Period} = (\text{REG}[06\text{h}] \text{ bits } 1-0, \text{REG}[05\text{h}] \text{ bits } 7-0) + 1 \text{ Lines}$
 $VNDP = \text{Vertical Non-Display Period} = \text{REG}[0A\text{h}] \text{ bits } 5-0 \text{ Lines}$
 $HDP = \text{Horizontal Display Period} = ((\text{REG}[04\text{h}] \text{ bits } 6-0) + 1) \times 8T_s$
 $HNDP = \text{Horizontal Non-Display Period} = (\text{REG}[08\text{h}] + 4) \times 8T_s$

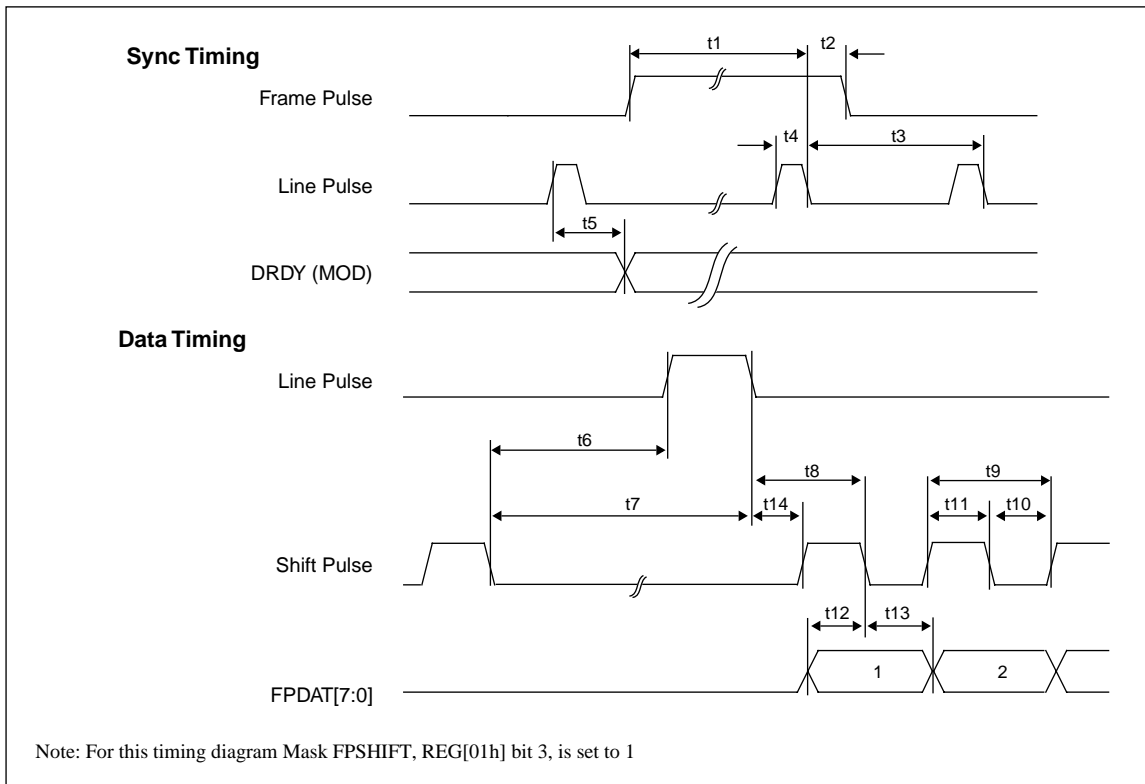

Figure 7-21 8-Bit Dual Monochrome Panel A.C. Timing

Table 7-15 8-Bit Dual Monochrome Panel A.C. Timing

Symbol	Parameter	Min.	Typ.	Max.	Units
t1	Frame Pulse setup to Line Pulse falling edge	note 2			(note 1)
t2	Frame Pulse hold from Line Pulse falling edge	9			Ts
t3	Line Pulse period	note 3			
t4	Line Pulse pulse width	9			Ts
t5	MOD delay from Line Pulse falling edge	1			Ts
t6	Shift Pulse falling edge to Line Pulse rising edge	note 5			
t7	Shift Pulse falling edge to Line Pulse falling edge	note 6			
t8	Line Pulse falling edge to Shift Pulse falling edge	$t_{14} + 4$			Ts
t9	Shift Pulse period	8			Ts
t10	Shift Pulse pulse width low	4			Ts
t11	Shift Pulse pulse width high	4			Ts
t12	FPDAT[7:0] setup to Shift Pulse falling edge	4			Ts
t13	FPDAT[7:0] hold to Shift Pulse falling edge	4			Ts
t14	Line Pulse falling edge to Shift Pulse rising edge	39			Ts

1. Ts = pixel clock period
2. $t_{1\min} = t_{3\min} - 9Ts$
3. $t_{3\min} = [(((REG[04h] \text{ bits } 6-0)+1) \times 8 + ((REG[08h] \text{ bits } 4-0) + 4) \times 8) \times 2]Ts$
5. $t_{6\min} = [((REG[08h] \text{ bits } 4-0) \times 2) \times 8 + 20]Ts$
6. $t_{7\min} = [((REG[08h] \text{ bits } 4-0) \times 2) \times 8 + 29]Ts$

7.3.9 8-Bit Dual Color Panel Timing

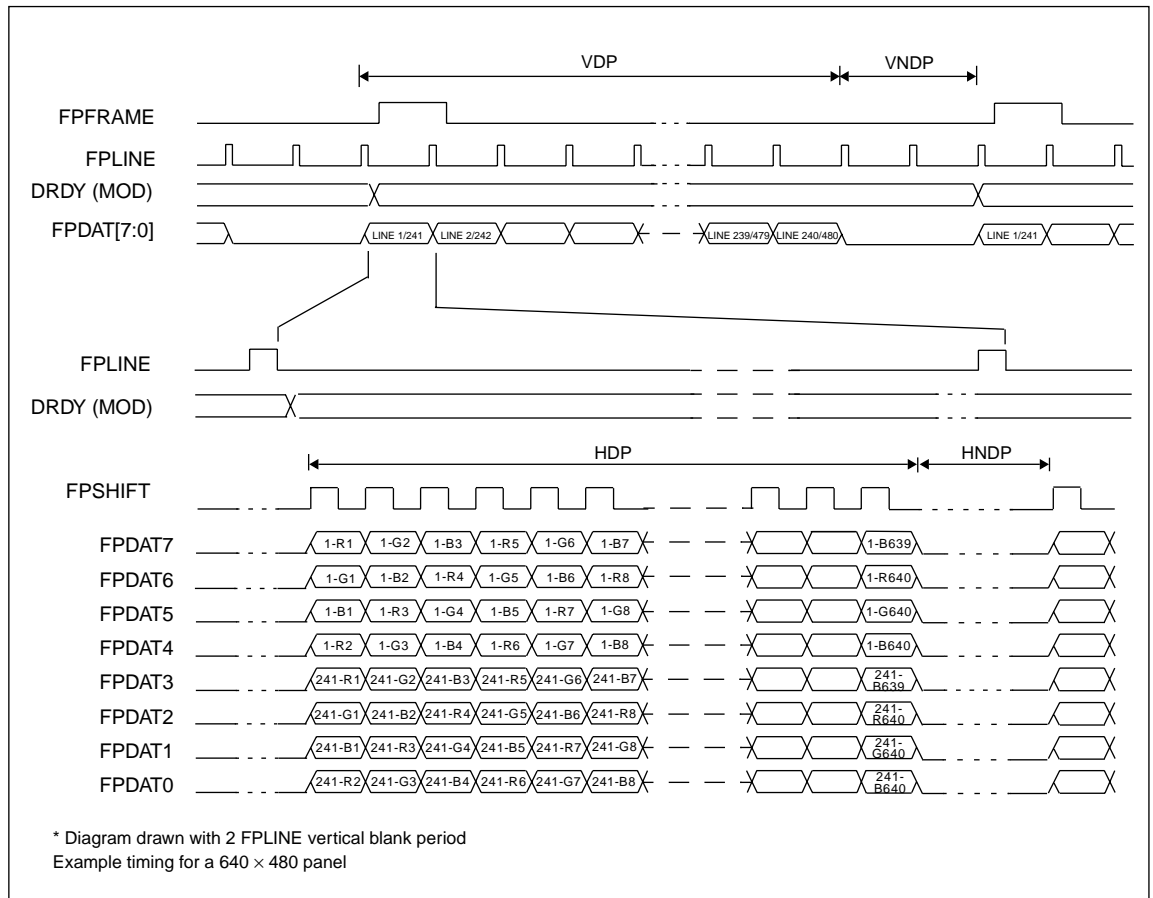

Figure 7-22 8-Bit Dual Color Panel Timing

$VDP = \text{Vertical Display Period} = (\text{REG}[06h] \text{ bits } 1-0, \text{REG}[05h] \text{ bits } 7-0) + 1 \text{ Lines}$
 $VNDP = \text{Vertical Non-Display Period} = \text{REG}[0Ah] \text{ bits } 5-0 \text{ Lines}$
 $HDP = \text{Horizontal Display Period} = ((\text{REG}[04h] \text{ bits } 6-0) + 1) \times 8Ts$
 $HNDP = \text{Horizontal Non-Display Period} = (\text{REG}[08h] + 4) \times 8Ts$

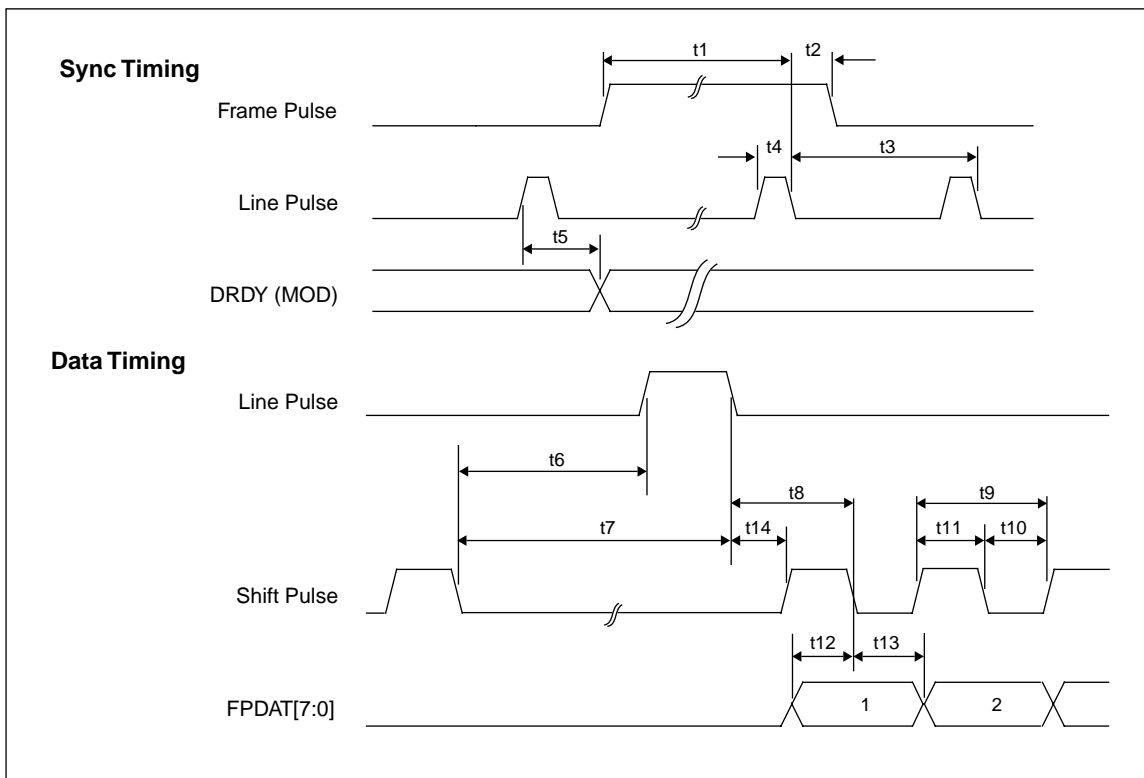

Figure 7-23 8-Bit Dual Color Panel A.C. Timing

Table 7-16 8-Bit Dual Color Panel A.C. Timing

Symbol	Parameter	Min.	Typ.	Max.	Units
t1	Frame Pulse setup to Line Pulse falling edge	note 2			(note 1)
t2	Frame Pulse hold from Line Pulse falling edge	9			Ts
t3	Line Pulse period	note 3			
t4	Line Pulse pulse width	9			Ts
t5	MOD delay from Line Pulse falling edge	1			Ts
t6	Shift Pulse falling edge to Line Pulse rising edge	note 5			
t7	Shift Pulse falling edge to Line Pulse falling edge	note 6			
t8	Line Pulse falling edge to Shift Pulse falling edge	t14 + 1			Ts
t9	Shift Pulse period	2			Ts
t10	Shift Pulse pulse width low	1			Ts
t11	Shift Pulse pulse width high	1			Ts
t12	FPDAT[7:0] setup to Shift Pulse falling edge	1			Ts
t13	FPDAT[7:0] hold to Shift Pulse falling edge	1			Ts
t14	Line Pulse falling edge to Shift Pulse rising edge	39			Ts

1. Ts = pixel clock period
2. $t_{1\min} = t_{3\min} - 9Ts$
3. $t_{3\min} = [(((REG[04h] \text{ bits } 6-0)+1) \times 8 + ((REG[08h] \text{ bits } 4-0) + 4) \times 8) \times 2]Ts$
5. $t_{6\min} = [((REG[08h] \text{ bits } 4-0) \times 2) \times 8 + 17]Ts$
6. $t_{7\min} = [((REG[08h] \text{ bits } 4-0) \times 2) \times 8 + 26]Ts$

7.3.10 12-Bit TFT/D-TFD Panel Timing

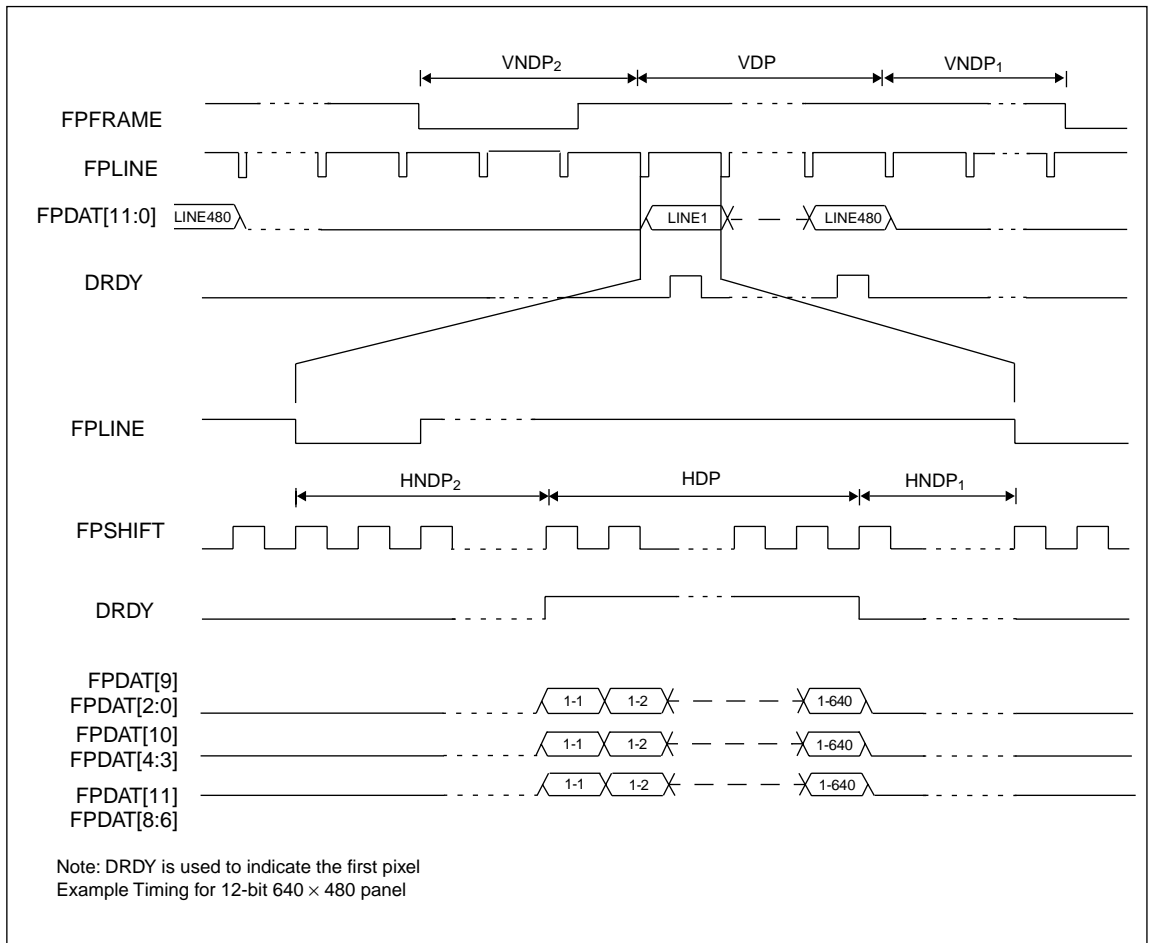

Figure 7-24 12-Bit TFT/D-TFD Panel Timing

- $VDP = \text{Vertical Display Period} = (\text{REG}[06\text{h}] \text{ bits } 1-0, \text{REG}[05\text{h}] \text{ bits } 7-0) + 1 \text{ Lines}$
 $VNDP = \text{Vertical Non-Display Period} = VNDP1 + VNDP2 = (\text{REG}[0A\text{h}] \text{ bits } 5-0) \text{ Lines}$
 $VNDP1 = \text{Vertical Non-Display Period } 1 = \text{REG}[09\text{h}] \text{ bits } 5-0 \text{ Lines}$
 $VNDP2 = \text{Vertical Non-Display Period } 2 = (\text{REG}[0A\text{h}] \text{ bits } 5-0) - (\text{REG}[09\text{h}] \text{ bits } 5-0) \text{ Lines}$
 $HDP = \text{Horizontal Display Period} = ((\text{REG}[04\text{h}] \text{ bits } 6-0) + 1) \times 8T_s$
 $HNDP = \text{Horizontal Non-Display Period} = HNDP1 + HNDP2 = (\text{REG}[08\text{h}] + 4) \times 8T_s$
 $HNDP1 = \text{Horizontal Non-Display Period } 1 = ((\text{REG}[07\text{h}] \text{ bits } 4-0) \times 8) + 16T_s$
 $HNDP2 = \text{Horizontal Non-Display Period } 2 = (((\text{REG}[08\text{h}] \text{ bits } 4-0) - (\text{REG}[07\text{h}] \text{ bits } 4-0)) \times 8) + 16T_s$

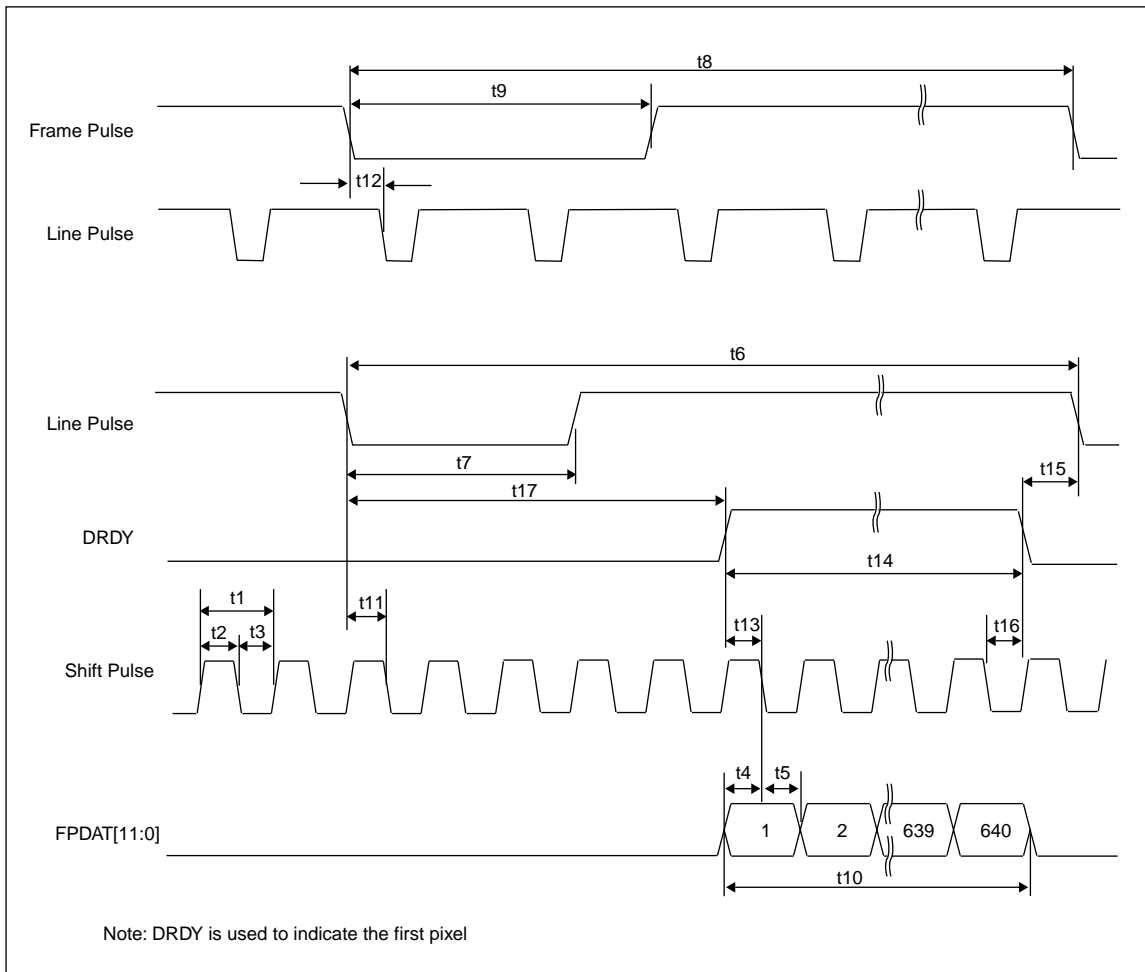

Figure 7-25 TFT/D-TFD A.C. Timing

Table 7-17 TFT/D-TFD A.C. Timing

Symbol	Parameter	Min.	Typ.	Max.	Units
t1	Shift Pulse period	1			(note 1)
t2	Shift Pulse pulse width high	0.5			Ts
t3	Shift Pulse pulse width low	0.5			Ts
t4	Data setup to Shift Pulse falling edge	0.5			Ts
t5	Data hold from Shift Pulse falling edge	0.5			Ts
t6	Line Pulse cycle time	note 2			
t7	Line Pulse pulse width low	9			Ts
t8	Frame Pulse cycle time	note 3			
t9	Frame Pulse pulse width low	2t6			
t10	Horizontal display period	note 4			
t11	Line Pulse setup to Shift Pulse falling edge	0.5			Ts
t12	Frame Pulse falling edge to Line Pulse falling edge phase difference	t6 - 18Ts			
t13	DRDY to Shift Pulse falling edge setup time	0.5			Ts
t14	DRDY pulse width	note 5			
t15	DRDY falling edge to Line Pulse falling edge	note 6			
t16	DRDY hold from Shift Pulse falling edge	0.5			Ts
t17	Line Pulse Falling edge to DRDY active	note 7		250	

1. Ts = pixel clock period
2. $t6_{\min}$ = $[((\text{REG}[04\text{h}] \text{ bits } 6-0)+1) \times 8 + ((\text{REG}[08\text{h}] \text{ bits } 4-0)+4) \times 8] \text{ Ts}$
3. $t8_{\min}$ = $[((\text{REG}[06\text{h}] \text{ bits } 1-0, \text{REG}[05\text{h}] \text{ bits } 7-0)+1) + (\text{REG}[0A\text{h}] \text{ bits } 6-0)] \text{ Lines}$
4. $t10_{\min}$ = $[((\text{REG}[04\text{h}] \text{ bits } 6-0)+1) \times 8] \text{ Ts}$
5. $t14_{\min}$ = $[((\text{REG}[04\text{h}] \text{ bits } 6-0)+1) \times 8] \text{ Ts}$
6. $t15_{\min}$ = $[(\text{REG}[07\text{h}] \text{ bits } 4-0) \times 8 + 16] \text{ Ts}$
7. $t17_{\min}$ = $[(\text{REG}[08\text{h}] \text{ bits } 4-0) - (\text{REG}[07]) \times 8 + 16] \text{ Ts}$

8 REGISTERS

8.1 Register Mapping

The S1D13705 registers are located in the upper 32 bytes of the 128K byte S1D13705 address range. The registers are accessible when CS# = 0 and AB[16:0] are in the range 1FFE0h through 1FFFFh.

8.2 Register Descriptions

Unless specified otherwise, all register bits are reset to 0 during power up. All bits marked n/a should be programmed 0.

REG[00h] Revision Code Register							Read Only.
Address = 1FFE0h							
Product Code Bit 5	Product Code Bit 4	Product Code Bit 3	Product Code Bit 2	Product Code Bit 1	Product Code Bit 0	Revision Code Bit 1	Revision Code Bit 0

bits 7-2 Product Code

This is a read-only register that indicates the product code of the chip. The product code is 001001.

bits 1-0 Revision Code

This is a read-only register that indicates the revision code of the chip. The revision code is 00.

REG[01h] Mode Register 0							Read/Write.
Address = 1FFE1h							
TFT/STN	Dual/Single	Color/Mono	FPLine Polar- ity	FPFrame Polarity	Mask FPSHIFT	Data Width Bit 1	Data Width Bit 0

bit 7 TFT/STN

When this bit = 0, STN (passive) panel mode is selected. When this bit = 1, TFT/D-TFD panel mode is selected. If TFT/D-TFD panel mode is selected, Dual/Single (REG[01h] bit 6) and Color/Mono (REG[01h] bit5) are ignored. See Table 8-1 for a comprehensive description of panel selection.

bit 6 Dual/Single

When this bit = 0, Single LCD panel drive is selected. When this bit = 1, Dual LCD panel drive is selected. See Table 8-1 for a comprehensive description of panel selection.

bit 5 Color/Mono

When this bit = 0, Monochrome LCD panel drive is selected. When this bit = 1, Color LCD panel drive is selected. See Table 8-1 for a comprehensive description of panel selection.

bit 4 FPLINE Polarity

This bit controls the polarity of FPLINE in TFT/D-TFD mode (no effect in passive panel mode). When this bit = 0, FPLINE is active low. When this bit = 1, FPLINE is active high.

bit 3 FPFRAME Polarity

This bit controls the polarity of FPFRAME in TFT/D-TFD mode (no effect in passive panel mode). When this bit = 0, FPFRAME is active low. When this bit = 1, FPFRAME is active high.

bit 2 Mask FPSHIFT

FPSHIFT is masked during non-display periods if either of the following two criteria is met:

1. Color passive panel is selected (REG[01h] bit 5 = 1)
2. This bit (REG[01h] bit 2) = 1

bits 1-0 Data Width Bits [1:0]

These bits select the display data format. See Table 8-1 below for a comprehensive description of panel selection.

Table 8-1 Panel Data Format

TFT/STN REG[01h] bit 7	Color/Mono REG[01h] bit 5	Dual/Single REG[01h] bit 6	Data Width Bit 1 REG[01h] bit 1	Data Width Bit 0 REG[01h] bit 0	Function	
0	0	0	0	0	Mono Single 4-bit passive LCD	
				1	Mono Single 8-bit passive LCD	
			1	0	reserved	
		1	1	reserved		
		1	0	0	0	reserved
				1	Mono Dual 8-bit passive LCD	
	1		0	reserved		
	1	0	0	0	0	Color Single 4-bit passive LCD
				1	Color Single 8-bit passive LCD format 1	
			1	0	reserved	
			1	1	Color Single 8-bit passive LCD format 2	
		1	0	0	0	reserved
				1	Color Dual 8-bit passive LCD	
			1	0	0	reserved
1				reserved		
1	X (don't care)			0	9-bit TFT/D-TFD panel	
	X (don't care)			1	12-bit TFT/D-TFD panel	

REG[02h] Mode Register 1

Address = 1FFE2h

Read/Write.

Bit-Per-Pixel Bit 1	Bit-Per-Pixel Bit 0	High Performance	Input Clock divide (CLKI/2)	Display Blank	Frame Repeat	Hardware Video Invert Enable	Software Video Invert
------------------------	------------------------	------------------	-----------------------------------	---------------	--------------	------------------------------------	--------------------------

bits 7-6 Bit-Per-Pixel Bits [1:0]

These bits select the color or gray-scale depth (Display Mode).

Table 8-2 Gray Scale/Color Mode Selection

Color/Mono REG[01h] bit 6	Bit-Per-Pixel Bit 1 REG[02h] bit 7	Bit-Per-Pixel Bit 0 REG[02h] bit 6	Display Mode	
0	0	0	2 Gray scale	1 bit-per-pixel
		1	4 Gray scale	2 bit-per-pixel
	1	0	16 Gray scale	4 bit-per-pixel
		1	reserved	
1	0	0	2 Colors	1 bit-per-pixel
		1	4 Colors	2 bit-per-pixel
	1	0	16 Colors	4 bit-per-pixel
		1	256 Colors	8 bit-per-pixel

bit 5 High Performance (Landscape Modes Only)
 When this bit = 0, the internal Memory Clock (MCLK) is a divided-down version of the Pixel Clock (PCLK). The denominator is dependent on the bit-per-pixel mode - see the table below.

Table 8-3 High Performance Selection

High Performance	BPP Bit 1	BPP Bit 0	Display Modes	
0	0	0	MClk = PClk/8	1 bit-per-pixel
		1	MClk = PClk/4	2 bit-per-pixel
	1	0	MClk = PClk/2	4 bit-per-pixel
		1	MClk = PClk	8 bit-per-pixel
1	X	X	MClk = PClk	

When this bit = 1, MCLK is fixed to the same frequency as PCLK for all bit-per-pixel modes. This provides a faster screen update performance in 1/2/4 bit-per-pixel modes, but also increases power consumption. This bit can be set to 1 just before a major screen update, then set back to 0 to save power after the update. This bit has no effect in portrait mode. Refer to “REG[1Bh] Portrait Mode Register” on page 1-54 for portrait mode clock selection.

bit 4 Input Clock Divide
 When this bit = 0, the Operating Clock(CLK) is the same as the Input Clock (CLKI).
 When this bit = 1, CLK = CLKI/2.

In landscape mode PCLK=CLK and MCLK is selected as per Table 8-3 .

In portrait mode, MCLK and PCLK are derived from CLK as shown in Table 8-8, “*Selection of PCLK and MCLK in Portrait Mode,*” on page 1-54.

bit 3 Display Blank
 This bit blanks the display image. When this bit = 1, the display is blanked (FPDAT lines to the panel are driven low). When this bit = 0, the display is enabled.

bit 2 Frame Repeat (EL support)
 This feature is used to improve Frame Rate Modulation of EL panels. When this bit = 1, an internal frame counter runs from 0 to 3FFFFh. When the frame counter rolls over, the modulated image pattern is repeated (every 1 hour when the frame rate is 72Hz). When this bit = 0, the modulated image pattern is never repeated.

bit 1 Hardware Video Invert Enable
 In passive panel modes (REG[01h] bit 7 = 0) FPDAT11 is available as either GPIO4 or hardware video invert. When this bit = 1, Hardware Video Invert is enabled via the FPDAT11 pin. When this bit = 0, FPDAT11 operates as GPIO4. See Table 8-4 below.

Note: Video data is inverted after the Look-Up Table.

bit 0 Software Video Invert
 When this bit = 1, Inverse Video Mode is selected. When this bit = 0, Standard Video Mode is selected. See Table 8-4 below.

Note: Video data is inverted after the Look-Up Table.

Table 8-4 Inverse Video Mode Select Options

Hardware Video Invert Enable	Software Video Invert (Passive and Active Panels)	FPDAT11 (Passive Panels Only)	Video Data
0	0	X	Normal
0	1	X	Inverse
1	X	0	Normal
1	X	1	Inverse

REG[03h] Mode Register 2							Read/Write
Address = 1FFE3h							
n/a	n/a	n/a	n/a	LCDPWR Override	Hardware Power Save Enable	Software Power Save Bit 1	Software Power Save Bit 0

bit 3 LCDPWR Override
When this bit = 1, LCDPWR is forced inactive, by-passing the LCD power sequencing. The 127 frame delay between Hardware Power Save and the LCD panel control signals is reduced to a single line. When this bit = 0, LCDPWR is controlled by the power sequencing logic within the S1D13705. See Figure 7-9, “Power Down/Up Timing,” on page 1-26 for further information.

bit 2 Hardware Power Save Enable
When this bit = 1 GPIO0 is used as the Hardware Power Save input pin. When this bit = 0, GPIO0 operates normally.

Table 8-5 Hardware Power Save/GPIO0 Operation

RESET# State	Hardware Power Save Enable REG[03h] bit 2	GPIO0 Config REG[18h] bit 0	GPIO0 Status/ Control REG[19h] bit 0	GPIO0 Operation
0	X	X	X	
1	0	0	reads pin status	GPIO0 Input (high impedance)
1	0	1	0	GPIO0 Output = 0
1	0	1	1	GPIO0 Output = 1
1	1	X	X	Hardware Power Save Input (active high)

bits 1-0 Software Power Save Bits [1: 0]
These bits select the Power Save Mode as shown in the following table.

Table 8-6 Software Power Save Mode Selection

Bit 1	Bit 0	Mode
0	0	Software Power Save
0	1	reserved
1	0	reserved
1	1	Normal Operation

Refer to Section 13 “Power Save Modes” on page 1-69 for a complete description of the power save modes.

REG[04h] Horizontal Panel Size Register							Read/Write
Address = 1FFE4h							
n/a	Horizontal Panel Size Bit 6	Horizontal Panel Size Bit 5	Horizontal Panel Size Bit 4	Horizontal Panel Size Bit 3	Horizontal Panel Size Bit 2	Horizontal Panel Size Bit 1	Horizontal Panel Size Bit 0

bits 6-0 Horizontal Panel Size Bits [6:0]
This register determines the horizontal resolution of the panel. This register must be programmed with a value calculated as follows:

$$\text{Horizontal Panel Size Register} = \left(\frac{\text{Horizontal Panel Resolution (pixels)}}{8} \right) - 1$$

Note: This register must not be set to a value less than 03h.

REG[05h] Vertical Panel Size Register (LSB)							Read/Write
Address = 1FFE5h							
Vertical Panel Size Bit 7	Vertical Panel Size Bit 6	Vertical Panel Size Bit 5	Vertical Panel Size Bit 4	Vertical Panel Size Bit 3	Vertical Panel Size Bit 2	Vertical Panel Size Bit 1	Vertical Panel Size Bit 0

REG[06h] Vertical Panel Size Register (MSB)							Read/Write
Address = 1FFE6h							
n/a	n/a	n/a	n/a	n/a	n/a	Vertical Panel Size Bit 9	Vertical Panel Size Bit 8

REG[05h] bits 7-0 Vertical Panel Size Bits [9:0]

REG[06h] bits 1-0 This 10-bit register determines the vertical resolution of the panel. This register must be programmed with a value calculated as follows.:

$$\text{Vertical Panel Size Register} = \text{Vertical Panel Resolution (lines)} - 1$$

3FFh is the maximum value of this register for a vertical resolution of 1024 lines.

REG[07h] FPLINE Start Position							Read/Write
Address = 1FFE7h							
n/a	n/a	n/a	FPLINE Start Position Bit 4	FPLINE Start Position Bit 3	FPLINE Start Position Bit 2	FPLINE Start Position Bit 1	FPLINE Start Position Bit 0

bits 4-0 FPLINE Start Position

These bits are used in TFT/D-TFD mode to specify the position of the FPLINE pulse. These bits specify the delay, in 8-pixel resolution, from the end of a line of display data (FPDAT) to the leading edge of FPLINE. This register is effective in TFT/D-TFD mode only (REG[01h] bit 7 = 1). This register is programmed as follows:

$$\text{FPLINEposition(pixels)} = (\text{REG}[07\text{h}] + 2) \times 8$$

The following constraint must be satisfied:

$$\text{REG}[07\text{h}] \leq \text{REG}[08\text{h}]$$

REG[08h] Horizontal Non-Display Period							Read/Write
Address = 1FFE8h							
n/a	n/a	n/a	Horizontal Non-Display Period Bit 4	Horizontal Non-Display Period Bit 3	Horizontal Non-Display Period Bit 2	Horizontal Non-Display Period Bit 1	Horizontal Non-Display Period Bit 0

bits 4-0 Horizontal Non-Display Period

These bits specify the horizontal non-display period in 8-pixel resolution.

$$\text{Horizontal Non-Display Period (pixels)} = (\text{REG}[08\text{h}] + 4) \times 8$$

REG[09h] FPF _{FRAME} Start Position							Read/Write
Address = 1FFE9h							
n/a	n/a	FPFRAME Start Position Bit 5	FPFRAME Start Position Bit 4	FPFRAME Start Position Bit 3	FPFRAME Start Position Bit 2	FPFRAME Start Position Bit 1	FPFRAME Start Position Bit 0

bits 5-0 FPF_{FRAME} Start Position

These bits are used in TFT/D-TFD mode to specify the position of the FPF_{FRAME} pulse. These bits specify the number of lines between the last line of display data (FPDAT) and the leading edge of FPF_{FRAME}. This register is effective in TFT/D-TFD mode only (REG[01h] bit 7 = 1). This register is programmed as follows:

$$\text{FPFRAMEposition}(\text{lines}) = \text{REG}[09\text{h}]$$

The contents of this register must be greater than zero and less than or equal to the Vertical Non-Display Period Register, i.e.

$$1 \leq \text{REG}[09\text{h}] \leq \text{REG}[0A\text{h}]$$

REG[0Ah] Vertical Non-Display Period							Read/Write
Address = 1FFEAh							
Vertical Non-Display Status	n/a	Vertical Non-Display Period Bit 5	Vertical Non-Display Period Bit 4	Vertical Non-Display Period Bit 3	Vertical Non-Display Period Bit 2	Vertical Non-Display Period Bit 1	Vertical Non-Display Period Bit 0

bit 7 Vertical Non-Display Status

This bit = 1 during the Vertical Non-Display period.

bits 5-0 Vertical Non-Display Period

These bits specify the vertical non-display period. This register is programmed as follows:

$$\text{Vertical Non-Display Period (lines)} = \text{REG}[0A\text{h}] \text{ bits } [5:0]$$

Note: This register should be set only once, on power-up during initialization.

REG[0Bh] MOD Rate Register							Read/Write
Address = 1FEBh							
n/a	n/a	MOD Rate Bit 5	MOD Rate Bit 4	MOD Rate Bit 3	MOD Rate Bit 2	MOD Rate Bit 1	MOD Rate Bit 0

bits 5-0 MOD Rate Bits [5:0]

When the value of this register is 0, the MOD output signal toggles every FPF_{FRAME}. For a non-zero value, the value in this register + 1 specifies the number of FPLINES between toggles of the MOD output signal. These bits are for passive LCD panels only.

REG[0Ch] Screen 1 Start Address Register (LSB)							
Address = 1FFEC _h							Read/Write
Screen 1 Start Address Bit 7	Screen 1 Start Address Bit 6	Screen 1 Start Address Bit 5	Screen 1 Start Address Bit 4	Screen 1 Start Address Bit 3	Screen 1 Start Address Bit 2	Screen 1 Start Address Bit 1	Screen 1 Start Address Bit 0

REG[0Dh] Screen 1 Start Address Register (MSB)							
Address = 1FFED _h							Read/Write
Screen 1 Start Address Bit 15	Screen 1 Start Address Bit 14	Screen 1 Start Address Bit 13	Screen 1 Start Address Bit 12	Screen 1 Start Address Bit 11	Screen 1 Start Address Bit 10	Screen 1 Start Address Bit 9	Screen 1 Start Address Bit 8

REG[0Dh] bits 7-0 Screen 1 Start Address Bits [15:0]

REG[0Ch] bits 7-0 These bits determine the **word address** of the start of Screen 1 in Landscape modes or the **byte address** of the start of Screen 1 in Portrait modes.

Note: For Portrait mode the most significant bit (bit 16) is located in REG[10h].

REG[0Eh] Screen 2 Start Address Register (LSB)							
Address = 1FFEE _h							Read/Write
Screen 2 Start Address Bit 7	Screen 2 Start Address Bit 6	Screen 2 Start Address Bit 5	Screen 2 Start Address Bit 4	Screen 2 Start Address Bit 3	Screen 2 Start Address Bit 2	Screen 2 Start Address Bit 1	Screen 2 Start Address Bit 0

REG[0Fh] Screen 2 Start Address Register (MSB)							
Address = 1FFEF _h							Read/Write
Screen 2 Start Address Bit 15	Screen 2 Start Address Bit 14	Screen 2 Start Address Bit 13	Screen 2 Start Address Bit 12	Screen 2 Start Address Bit 11	Screen 2 Start Address Bit 10	Screen 2 Start Address Bit 9	Screen 2 Start Address Bit 8

REG[0Fh] bits 7-0 Screen 2 Start Address Bits [15:0]

REG[0Eh] bits 7-0 These bits determine the **word address** of the start of Screen 2 in Landscape modes only and has no effect in Portrait modes.

REG[10h] Screen Start Address Overflow Register							
Address = 1FFF0 _h							Read/Write
n/a	n/a	n/a	n/a	n/a	n/a	n/a	Screen 1 Start Address Bit 16

bit 0 Screen 1 Start Address Bit 16
 This bit is the most significant bit of Screen 1 Start Address for Portrait mode. This bit has no effect in Landscape mode.

REG[11h] Memory Address Offset Register							Read/Write
Address = 1FFF1h							
Memory Address Offset Bit 7	Memory Address Offset Bit 6	Memory Address Offset Bit 5	Memory Address Offset Bit 4	Memory Address Offset Bit 3	Memory Address Offset Bit 2	Memory Address Offset Bit 1	Memory Address Offset Bit 0

bits 7-0 Memory Address Offset Bits [7:0] (Landscape Modes Only)

This register is used to create a virtual image by setting a word offset between the last address of one line and the first address of the following line. If this register is not equal to zero, then a virtual image is formed. The displayed image is a window into the larger virtual image. See Figure 8-1, “*Screen-Register Relationship*,” on page 1-52.

This register has no effect in portrait modes. See “*REG[1Ch] Line Byte Count Register for Portrait Mode*” on page 1-55.

REG[12h] Screen 1 Vertical Size Register (LSB)							Read/Write
Address = 1FFF2h							
Screen 1 Vertical Size Bit 7	Screen 1 Vertical Size Bit 6	Screen 1 Vertical Size Bit 5	Screen 1 Vertical Size Bit 4	Screen 1 Vertical Size Bit 3	Screen 1 Vertical Size Bit 2	Screen 1 Vertical Size Bit 1	Screen 1 Vertical Size Bit 0

REG[13h] Screen 1 Vertical Size Register (MSB)							Read/Write
Address = 1FFF3h							
n/a	n/a	n/a	n/a	n/a	n/a	Screen 1 Vertical Size Bit 9	Screen 1 Vertical Size Bit 8

REG[13h] bits 1-0 Screen 1 Vertical Size Bits [9:0]

REG[12h] bits 7-0 These bits determine the height (in lines) of Screen 1.

In landscape modes, if this register is programmed with a value, *n*, where *n* is less than the Vertical Panel Size (REG[06h], REG[05h]), then lines 0 to *n* of the panel contain Screen 1 and lines *n*+1 to REG[06h], REG[05h] of the panel contain Screen 2. See Figure 8-1, “*Screen-Register Relationship*,” on page 1-52.

In portrait modes this register must be programmed greater than, or equal to the Vertical Panel Size, REG[06h] and REG[05h]. See “*12 SwivelView Mode*” on page 1-64.

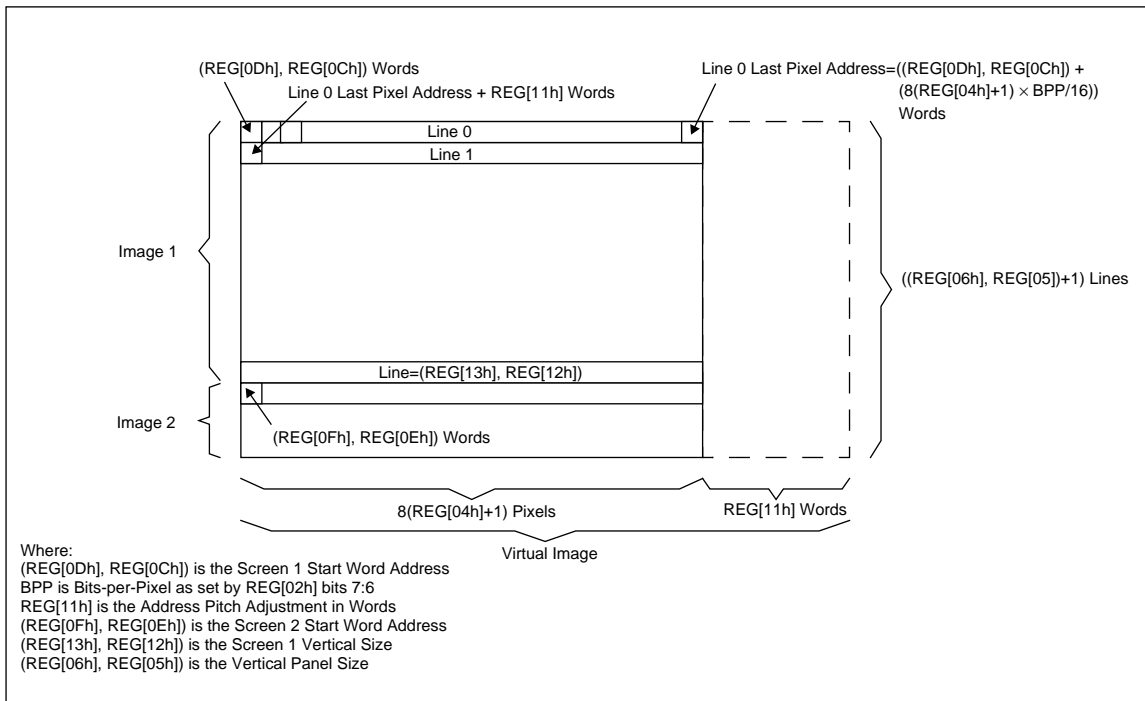

Figure 8-1 Screen-Register Relationship

Consider an example where REG[13h], REG[12] = 0CEh for a 320x240 display system. The upper 207 lines (CEh + 1) of the panel show an image from the Screen 1 Start Word Address. The remaining 33 lines show an image from the Screen 2 Start Word Address.

REG[15h] Look-Up Table Address Register							Read/Write
Address = 1FFF5h							
LUT Address Bit 7	LUT Address Bit 6	LUT Address Bit 5	LUT Address Bit 4	LUT Address Bit 3	LUT Address Bit 2	LUT Address Bit 1	LUT Address Bit 0

bits 7-0 LUT Address Bits [7:0]

These 8 bits control a pointer into the Look-Up Tables (LUT). The S1D13705 has three 256-position, 4-bit wide LUTs, one for each of red, green, and blue – refer to Section 11 “Look-Up Table Architecture” on page 1-58 for details.

This register selects which LUT entry is read/write accessible through the LUT Data Register (REG[17h]). Writing the LUT Address Register automatically sets the pointer to the Red LUT. Accesses to the LUT Data Register automatically increment the pointer.

For example, writing a value 03h into the LUT Address Register sets the pointer to R[3]. A subsequent access to the LUT Data Register accesses R[3] and moves the pointer onto G[3]. Subsequent accesses to the LUT Data Register move the pointer onto B[3], R[4], G[4], B[4], R[5], etc.

Note: The RGB data is inserted into the LUT after the Blue data is written, i.e. all three colors must be written before the LUT is updated.

REG[17h] Look-Up Table Data Register							Read/Write
Address = 1FFF7h							
LUT Data Bit 3	LUT Data Bit 2	LUT Data Bit 1	LUT Data Bit 0	n/a	n/a	n/a	n/a

bits 7-4 LUT Data Bits [3:0]

This register is used to read/write the RGB Look-Up Tables. This register accesses the entry at the pointer controlled by the Look-Up Table Address Register (REG[15h]).

Accesses to the Look-Up Table Data Register automatically increment the pointer.

Note: The RGB data is inserted into the LUT after the Blue data is written, i.e. all three colors must be written before the LUT is updated.

REG[18h] GPIO Configuration Control Register							Read/Write
Address = 1FFF8h							
n/a	n/a	n/a	GPIO4 Pin IO Configuration	GPIO3 Pin IO Configuration	GPIO2 Pin IO Configuration	GPIO1 Pin IO Configuration	GPIO0 Pin IO Configuration

bits 4-0 GPIO[4:0] Pin IO Configuration

These bits determine the direction of the GPIO[4:0] pins.

When the GPIO Pin IO Configuration bit = 0, the corresponding GPIO pin is configured as an input. The input can be read at the GPIO Status/Control Register bit. See “REG[19h] GPIO Status/Control Register”.

When the GPIO Pin IO Configuration bit = 1, the corresponding GPIO pin is configured as an output. The output can be controlled by writing the GPIO Status/Control Register bit.

Note: These bits have no effect when the GPIO pin is configured for a specific function (i.e. as FPDAT[11:8] for TFT/D-TFD operation).

When configured as IO, all unused pins must be tied to IO V_{DD}.

REG[19h] GPIO Status/Control Register							Read/Write
Address = 1FFF9h							
n/a	n/a	n/a	GPIO4 Pin IO Status	GPIO3 Pin IO Status	GPIO2 Pin IO Status	GPIO1 Pin IO Status	GPIO0 Pin IO Status

bits 4-0 GPIO[4:0] Status

When the GPIO pin is configured as an input, the corresponding GPIO Status bit is used to read the pin input. See REG[18h] above.

When the GPIO pin is configured as an output, the corresponding GPIO Status bit is used to control the pin output.

REG[1Ah] Scratch Pad Register								Read/Write
Address = 1FFFAh								
Scratch bit 7	Scratch bit 6	Scratch bit 5	Scratch bit 4	Scratch bit 3	Scratch bit 2	Scratch bit 1	Scratch bit 0	

bits 7-0 Scratch Pad Register

This register contains general use read/write bits. These bits have no effect on hardware.

REG[1Bh] Portrait Mode Register							Read/Write	
Address = 1FFFBh								
Portrait Mode Enable	Portrait Mode Select	n/a	n/a	n/a	reserved	Portrait Mode Pixel Clock Select Bit 1	Portrait Mode Pixel Clock Select Bit 0	

bit 7 Portrait Mode Enable
 When this bit = 1, Portrait Mode is enabled. When this bit = 0, Landscape Mode is enabled.

bit 6 Portrait Mode Select
 When this bit = 0, Default Portrait Mode is selected. When this bit = 1, Alternate Portrait Mode is selected. See Section 12 “SwivelView Mode” on page 1-64 for further information on Portrait Mode.

The following table shows the selection of Portrait Mode.

Table 8-7 Selection of Portrait Mode

Portrait Mode Enable (REG[1Bh] bit 7)	Portrait Mode Select (REG[1Bh] bit 6)	Mode
0	X	Landscape
1	0	Default Portrait
1	1	Alternate Portrait

bit 2 reserved
 reserved bits must be set to 0.

bits 1-0 Portrait Mode Pixel Clock Select Bits [1:0]
 These two bits select the Pixel Clock (PCLK) source in Portrait Mode - these bits have no effect in Landscape Mode. The following table shows the selection of PCLK and MCLK in Portrait Mode - see Section 12 “SwivelView Mode” on page 1-64 for details.

Table 8-8 Selection of PCLK and MCLK in Portrait Mode

Portrait Mode Enable (REG[1Bh] bit 7)	Portrait Mode Select (REG[1Bh] bit 6)	Pixel Clock (PCLK) Select (REG[1Bh] bits [1:0])		PCLK =	MCLK =
		Bit 1	Bit 0		
0	X	X	X	CLK	See Reg[02h] bit 5
1	0	0	0	CLK	CLK
1	0	0	1	CLK/2	CLK/2
1	0	1	0	CLK/4	CLK/4
1	0	1	1	CLK/8	CLK/8
1	1	0	0	CLK/2	CLK
1	1	0	1	CLK/2	CLK
1	1	1	0	CLK/4	CLK/2
1	1	1	1	CLK/8	CLK/4

Where CLK is CLKI (REG[02h] bit 4 = 0) or CLKI/2 (REG[02h] bit 4 = 1)

REG[1Ch] Line Byte Count Register for Portrait Mode							Read/Write
Address = 1FFFCh							
Line Byte Count bit 7	Line Byte Count bit 6	Line Byte Count bit 5	Line Byte Count bit 4	Line Byte Count bit 3	Line Byte Count bit 2	Line Byte Count bit 1	Line Byte Count bit 0

bits 7-0 Line Byte Count Bits [7:0]

This register is the byte count from the beginning of one line to the beginning of the next consecutive line (commonly called “stride” by programmers). This register may be used to create a virtual image in portrait mode.

When this register = 00 the “stride” = 256 bytes. This value is used for 240×320 8 bpp default portrait mode

When the Line Byte Count Register = n, where $1 \leq n \leq FFh$, the “stride” = n bytes.

REG[1Eh] and REG[1Fh]

REG[1Eh] and REG[1Fh] are reserved for factory S1D13705 testing and should not be written. Any value written to these registers may result in damage to the S1D13705 and/or any panel connected to the S1D13705.

9 FRAME RATE CALCULATION

The following formulae are used to calculate the display frame rate.

TFT/D-TFD and Passive Single-Panel modes

$$\text{FrameRate} = \frac{f_{\text{PCLK}}}{(\text{HDP} + \text{HNDP}) \times (\text{VDP} + \text{VNDP})}$$

Where: f_{PCLK} = PCLK frequency (Hz)

HDP = Horizontal Display Period = ((REG[04h] bits 6-0) + 1) × 8 Pixels

HNDP = Horizontal Non-Display Period = ((REG[08h] bits 4-0) + 4) × 8 Pixels

VDP = Vertical Display Period = ((REG[06h] bits 1-0, REG[05h] bits 7-0) + 1) Lines

VNDP = Vertical Non-Display Period = (REG[0Ah] bits 5-0) Lines

Passive Dual-Panel mode

$$\text{FrameRate} = \frac{f_{\text{PCLK}}}{2 \times (\text{HDP} + \text{HNDP}) \times \left(\frac{\text{VDP}}{2} + \text{VNDP}\right)}$$

Where: f_{PCLK} = PCLK frequency (Hz)

HDP = Horizontal Display Period = ((REG[04h] bits 6-0) + 1) × 8 Pixels

HNDP = Horizontal Non-Display Period = ((REG[08h] bits 4-0) + 4) × 8 Pixels

VDP = Vertical Display Period = ((REG[06h] bits 1-0, REG[05h] bits 7-0) + 1) Lines

VNDP = Vertical Non-Display Period = (REG[0Ah] bits 5-0) Lines

10 DISPLAY DATA FORMATS

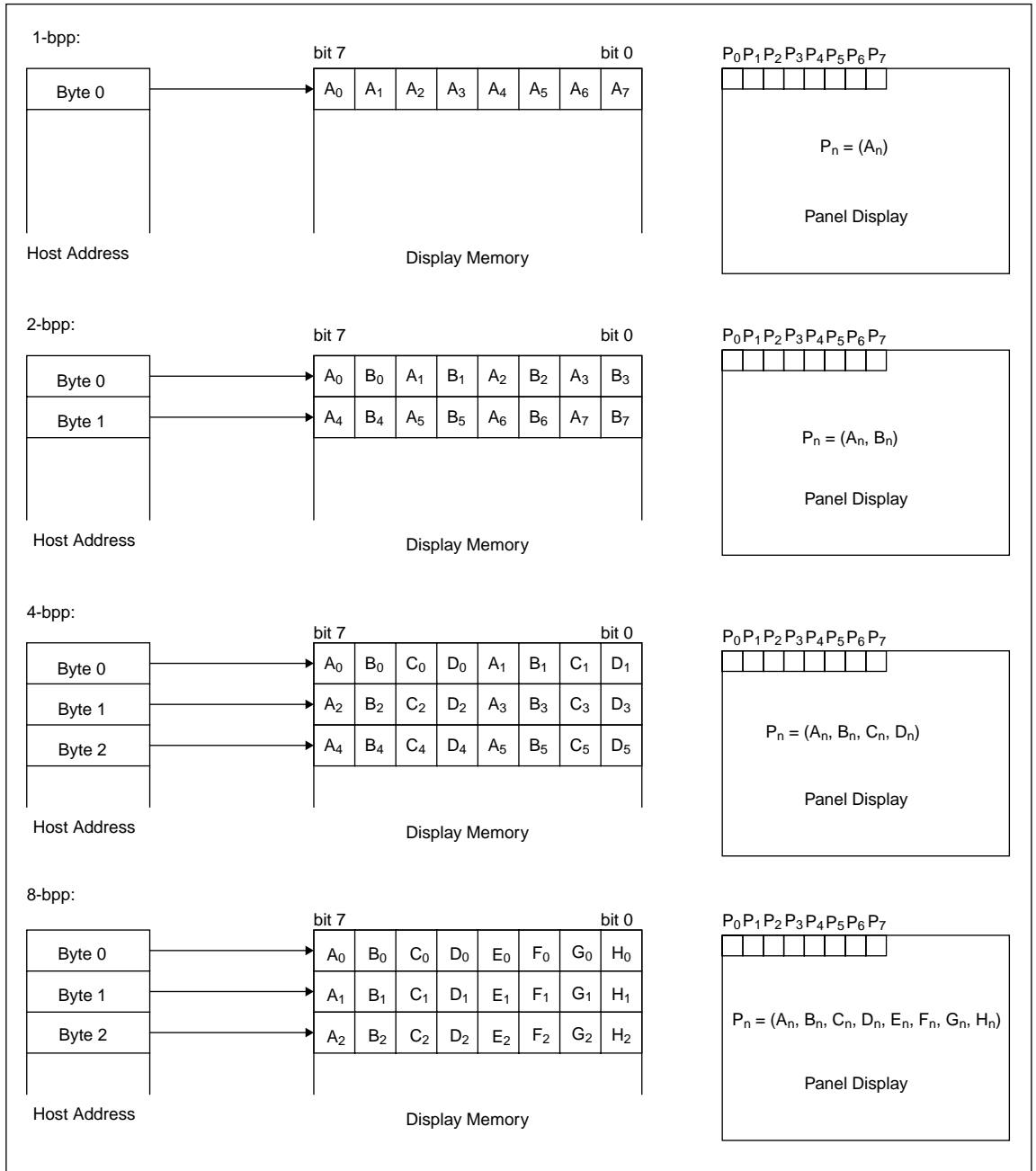

Figure 10-1 1/2/4/8 Bit-Per-Pixel Display Data Memory Organization

11 LOOK-UP TABLE ARCHITECTURE

The following figures are intended to show the display data output path only.

Note: When Video Data Invert is enabled the video data is inverted after the Look-Up Table.

11.1 Monochrome Modes

The green Look-Up Table (LUT) is used for all monochrome modes.

11.1.1 1 Bit-per-pixel Monochrome Mode

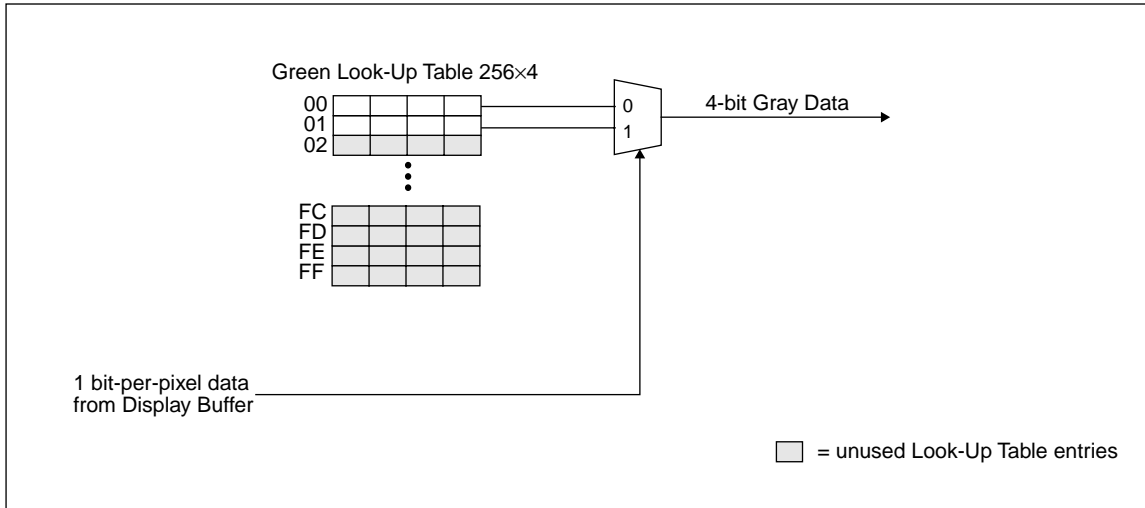

Figure 11-1 1 Bit-per-pixel Monochrome Mode Data Output Path

11.1.2 2 Bit-per-pixel Monochrome Mode

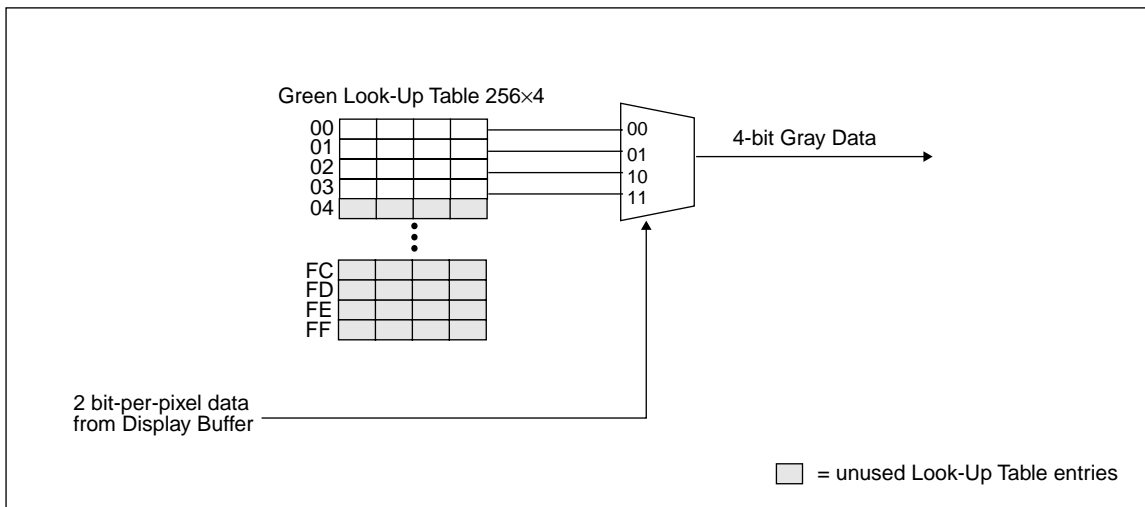

Figure 11-2 2 Bit-per-pixel Monochrome Mode Data Output Path

11.1.3 4 Bit-per-pixel Monochrome Mode

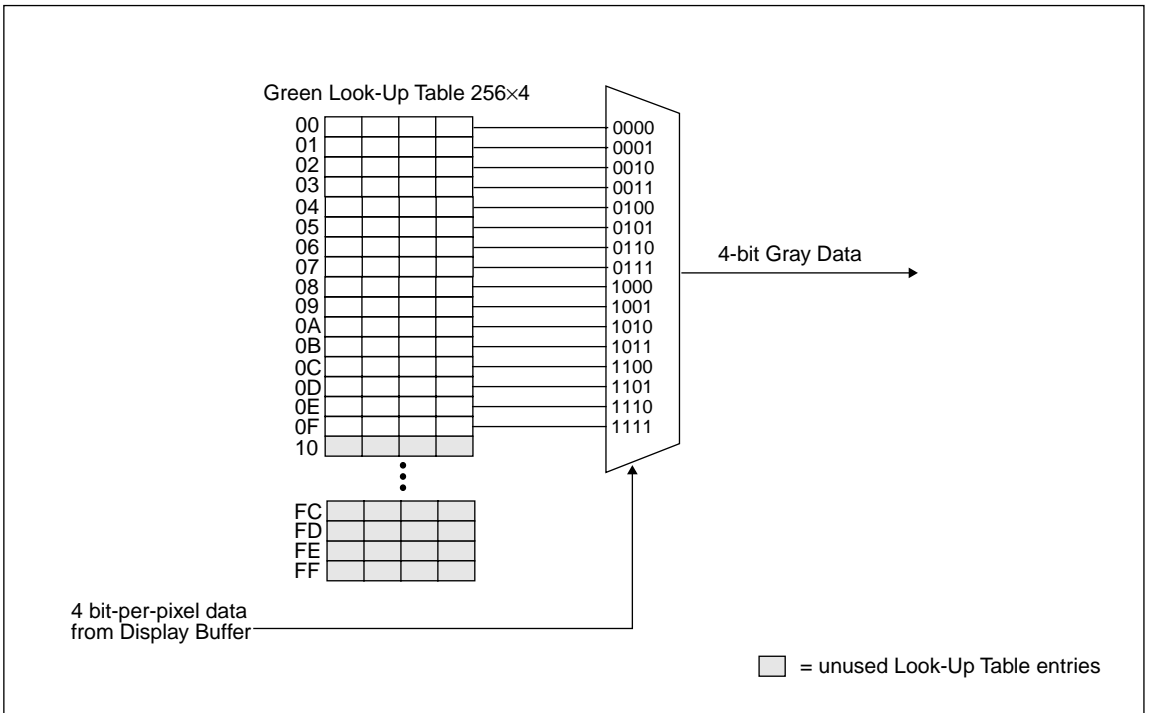

Figure 11-3 4 Bit-per-pixel Monochrome Mode Data Output Path

11.2 Color Modes

11.2.1 1 Bit-per-pixel Color Mode

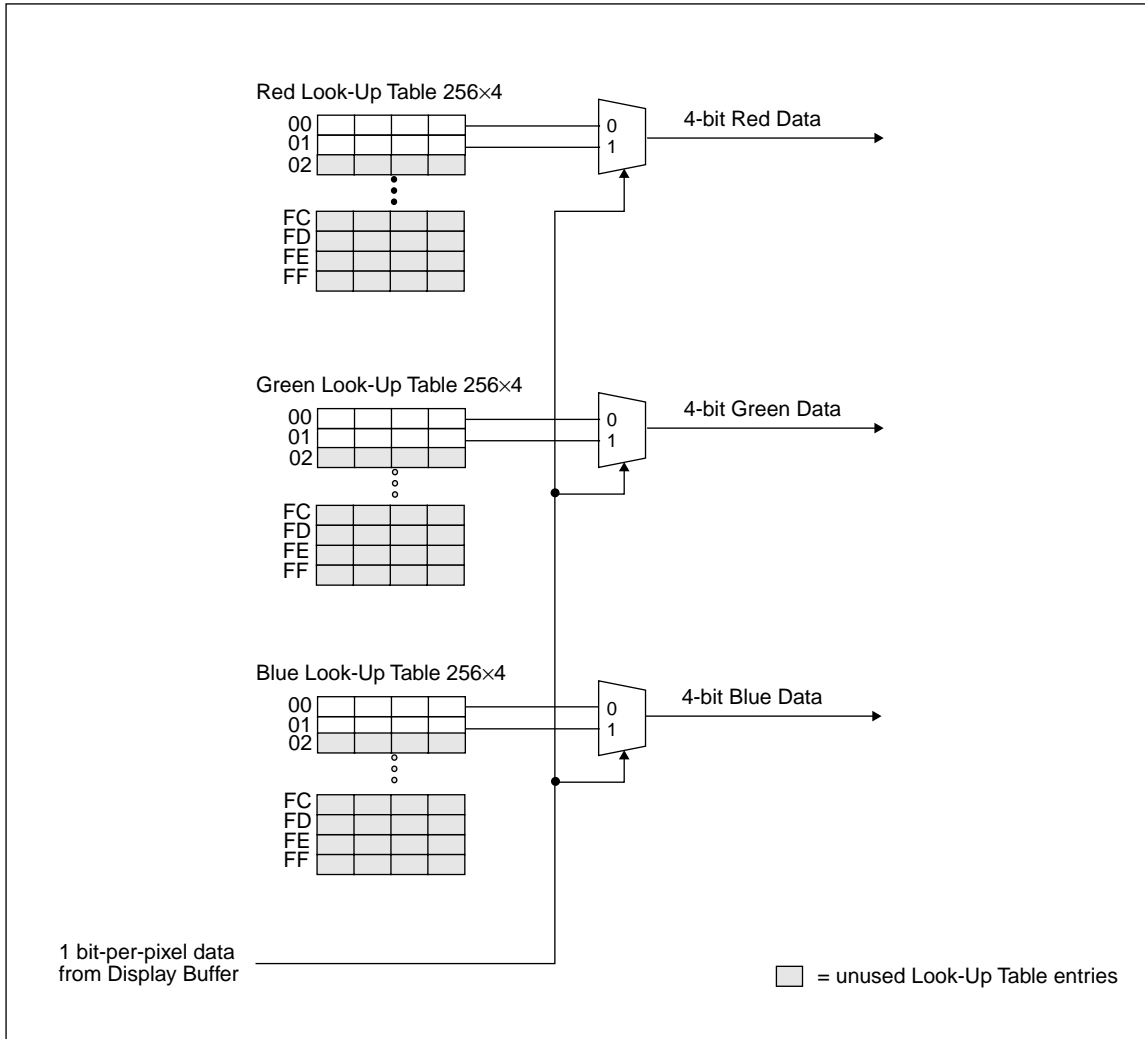

Figure 11-4 1 Bit-per-pixel Color Mode Data Output Path

11.2.2 2 Bit-per-pixel Color Mode

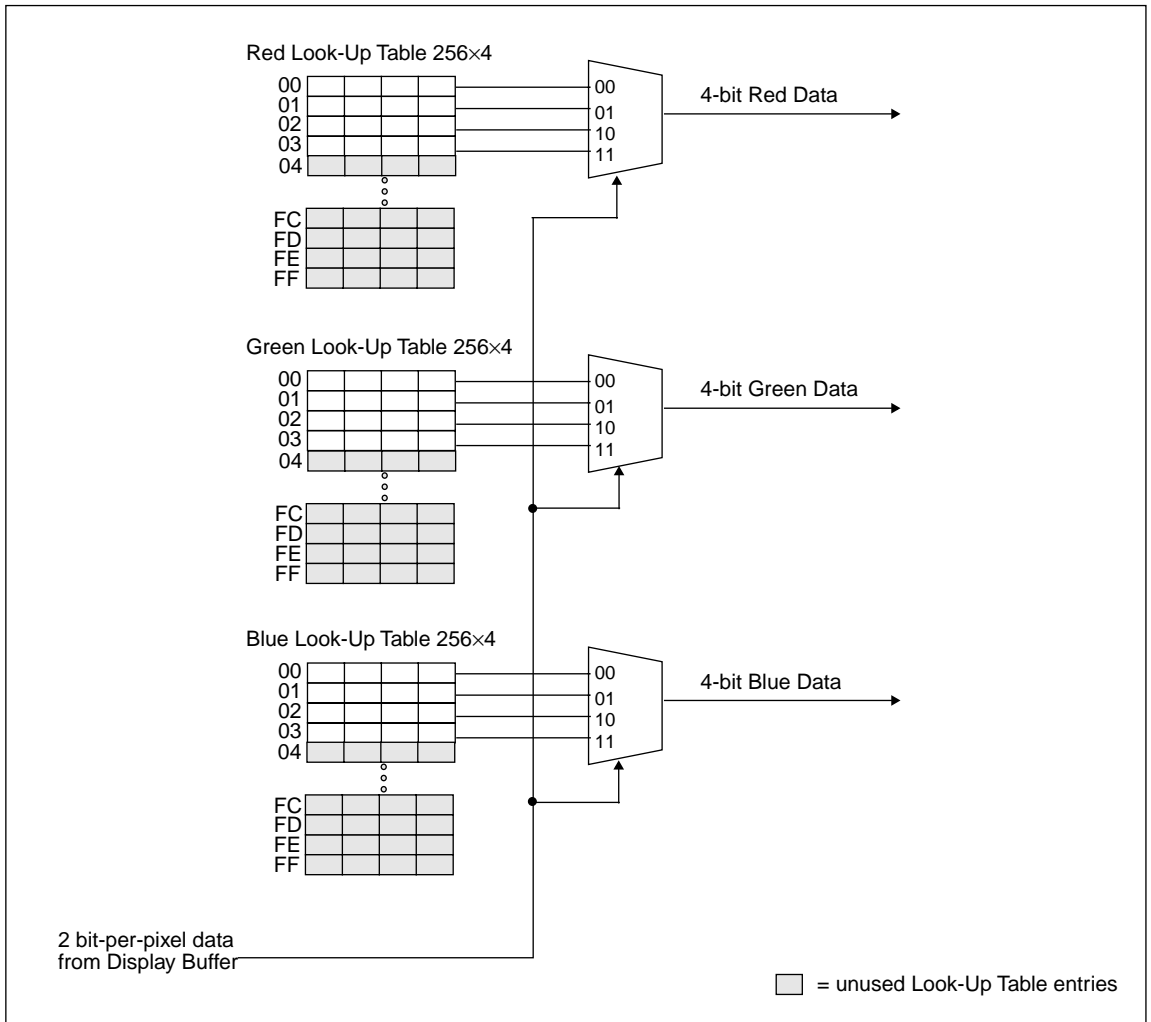

Figure 11-5 2 Bit-per-pixel Color Mode Data Output Path

11.2.3 4 Bit-per-pixel Color Mode

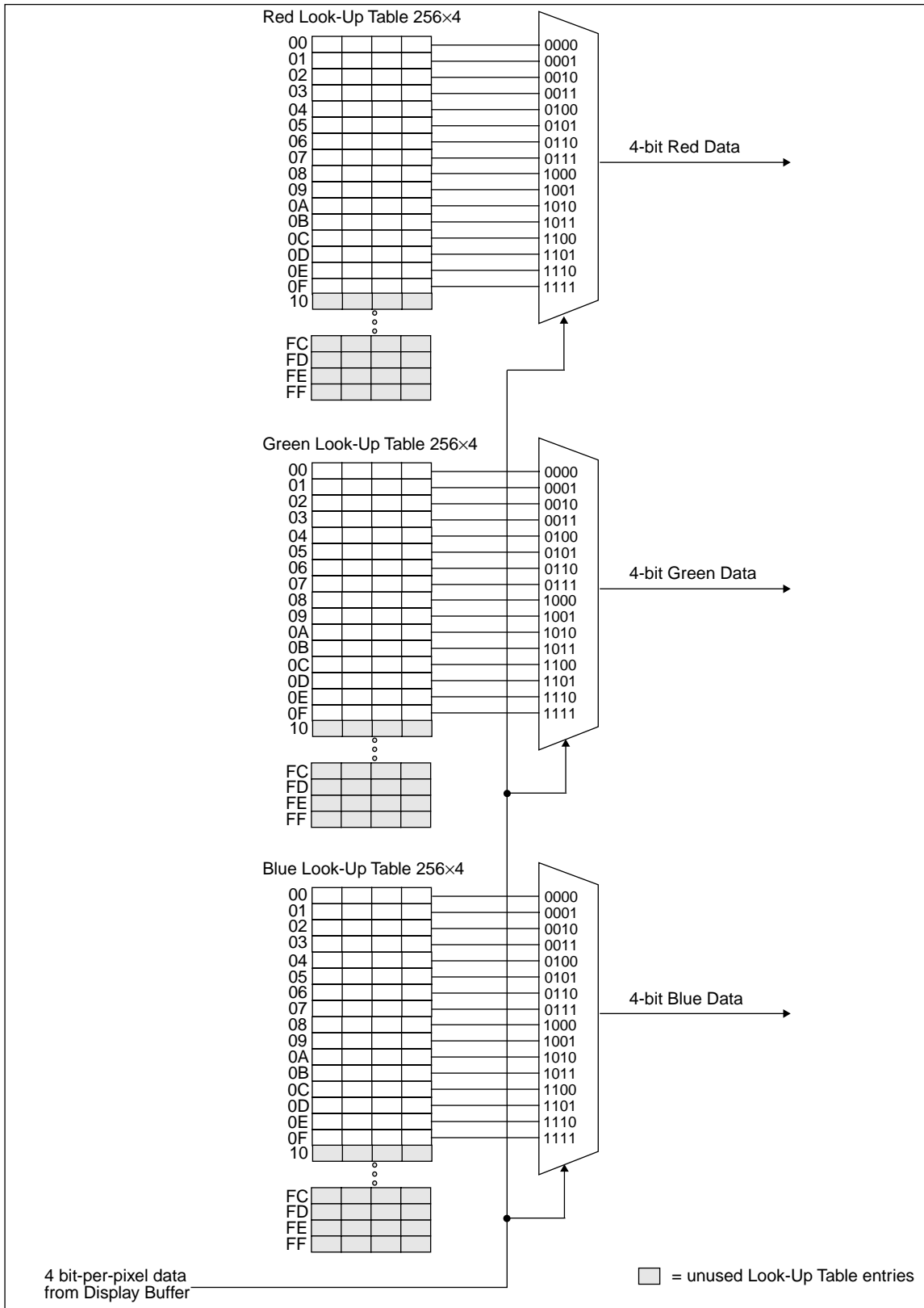

Figure 11-6 4 Bit-per-pixel Color Mode Data Output Path

11.2.4 8 Bit-per-pixel Color Mode

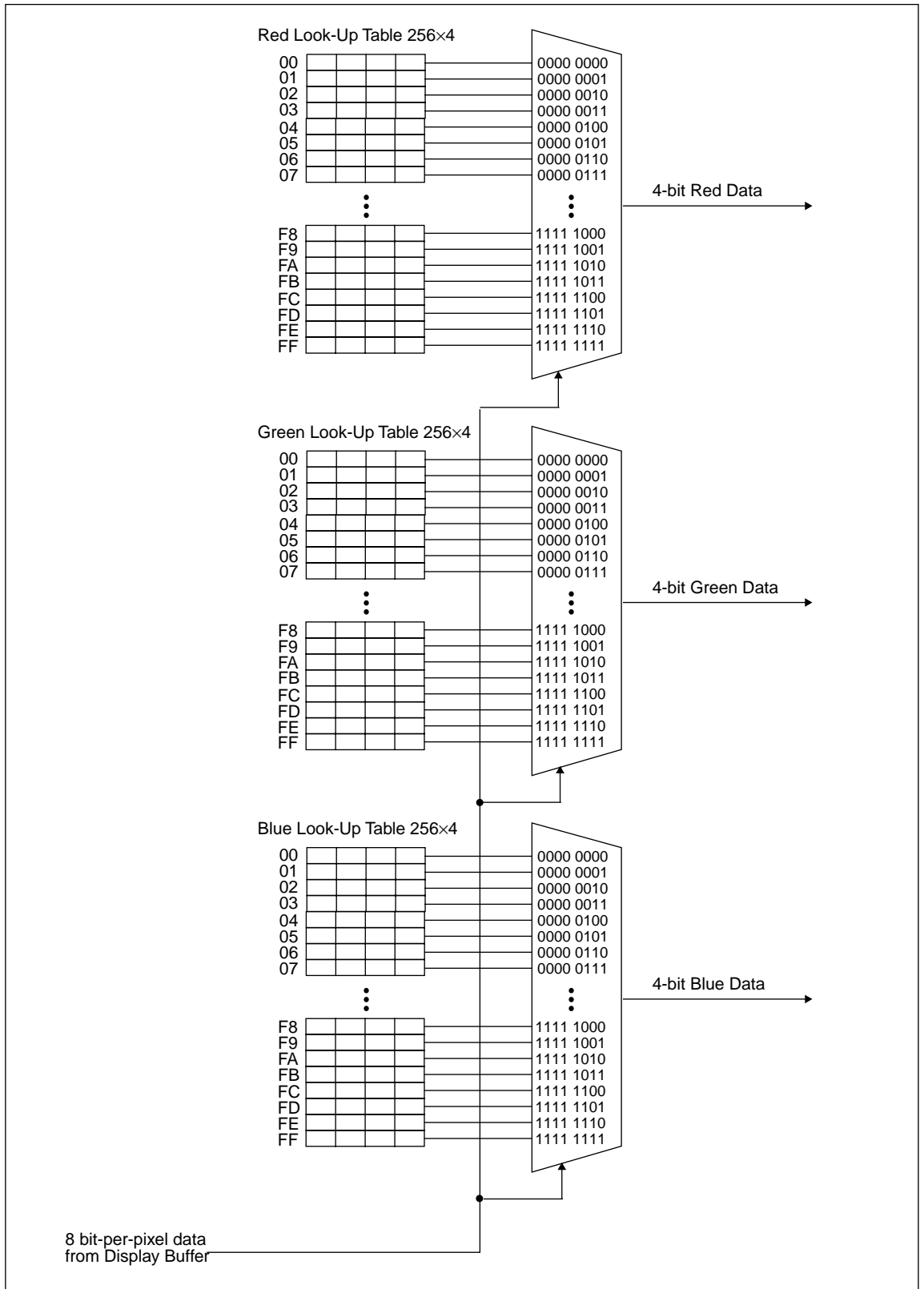

Figure 11-7 8 Bit-per-pixel Color Mode Data Output Path

12 SWIVELVIEW MODE

Many of today's applications use the LCD panel in a portrait orientation. In this case it becomes necessary to "rotate" the displayed image by 90°. This rotation can be done by software at the expense of performance or, it can be done by the S1D13705 hardware with no CPU penalty.

There are two SwivelView modes: Default SwivelView Mode and Alternate SwivelView Mode.

12.1 Default SwivelView Mode

Default SwivelView Mode requires the portrait image width be a power of two, e.g. a 240-line panel requires a minimum virtual image width of 256. This mode should be used whenever the required virtual image can be contained within the integrated display buffer (i.e. virtual image size ≤ 80K bytes), as it consumes less power than the Alternate SwivelView Mode.

For example, the panel size is 320x240 and the display mode is 8 bit-per-pixel. The virtual image size is 320x256 which can be contained within the 80K Byte display buffer.

Default SwivelView Mode also requires Memory Clock (MCLK) ≥ Pixel Clock (PCLK).

The following figure shows how the programmer sees a 240x320 image and how the image is displayed. The application image is written to the S1D13705 in the following sense: A-B-C-D. The display is refreshed by the S1D13705 in the following sense: B-D-A-C.

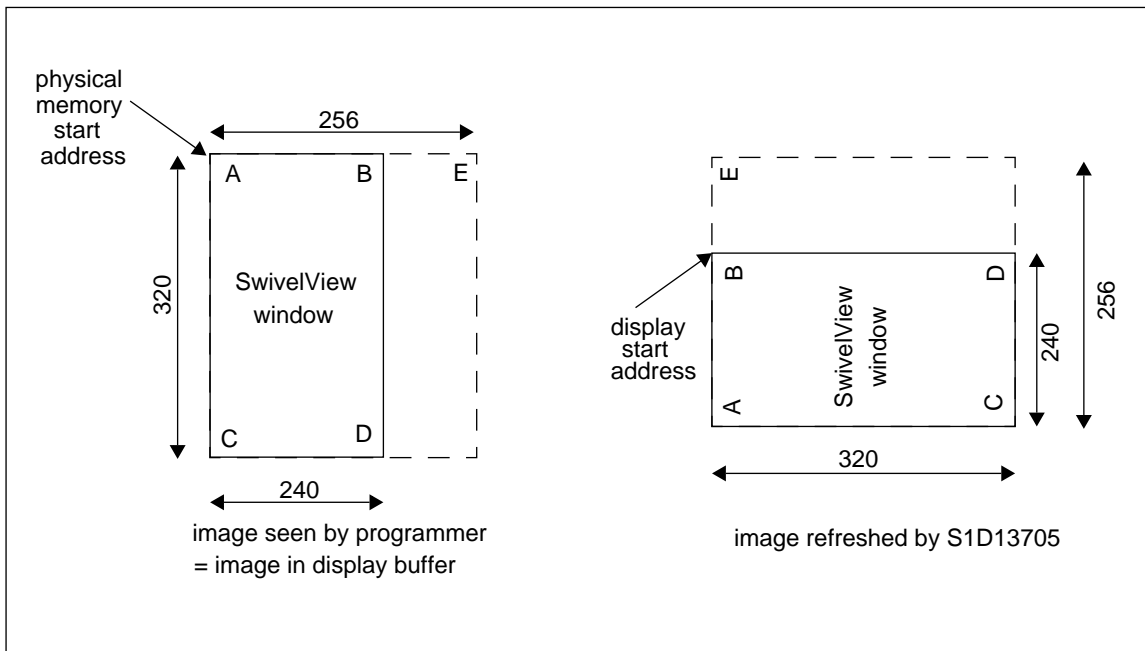

Figure 12-1 Relationship Between The Screen Image and the Image Refreshed by S1D13705 in Default Mode

12.1.1 How to Set Up Default SwivelView Mode

The following describes the register settings needed to set up Default SwivelView Mode for a 240×320×8 bpp image:

- Select Default SwivelView Mode: REG[1Bh] bit 7 = 1 and bit 6 = 0
- The display refresh circuitry starts at pixel “B”, therefore the Screen 1 Start Address register must be programmed with the address of pixel “B”, i.e.

$$\begin{aligned} \text{REG}[10\text{h}], \text{REG}[0\text{Dh}], \text{REG}[0\text{Ch}] &= \text{AddressOfPixelB} \\ &= (\text{AddressOfPixelA} + \text{ByteOffset}) \\ &= \text{AddressOfPixelA} + \left(\frac{240\text{pixels} \times 8\text{bpp}}{8\text{bbp}} \right) - 1 \\ &= \text{AddressOfPixelA} + \text{EFh} \end{aligned}$$

Where bpp is bits-per-pixel and bpb is bits-per-byte.

- The Line Byte Count Register for SwivelView Mode must be set to the virtual-image width in bytes, i.e.

$$\text{REG}[1\text{Ch}] = \frac{256}{(8\text{bpb}) \div (8\text{bpp})} = \frac{256}{1} = 256 = 00\text{h} \quad : \text{ see REG}[1\text{Ch}] \text{ for explanation}$$

Where bpb is bits-per-byte and bpp is bits-per-pixel.

- Panning is achieved by changing the Screen 1 Start Address register:
- Increment the register by 1 to pan horizontally by one byte, e.g. one pixel in 8 bpp mode
- Increment the register by twice the effective value of the Line Byte Count register to pan vertically by two lines, e.g. add 200h to pan by two lines in the example above.

Note: Vertical panning by a single line is not supported in Default SwivelView Mode.

12.2 Alternate SwivelView Mode

Alternate SwivelView Mode may be used when the virtual image size of Default SwivelView Mode cannot be contained in the 80K byte integrated frame buffer. For example, the panel size is 480×320 and the display mode is 4 bit-per-pixel. The minimum virtual image size for Default SwivelView Mode would be 480×512 which requires 122,880 bytes. Alternate SwivelView Mode requires a panel size of only 480×320 which needs only 76,800 bytes.

Alternate SwivelView Mode requires the Memory Clock (MCLK) to be at least twice the frequency of the Pixel Clock (PCLK), i.e. $MCLK \geq 2 \times PCLK$. This makes the power consumption in Alternate SwivelView Mode higher than in Default SwivelView Mode.

The following figure shows how the programmer sees a 480×320 image and how the image is being displayed. The application image is written to the S1D13705 in the following sense: A–B–C–D. The display is refreshed by the S1D13705 in the following sense: B–D–A–C.

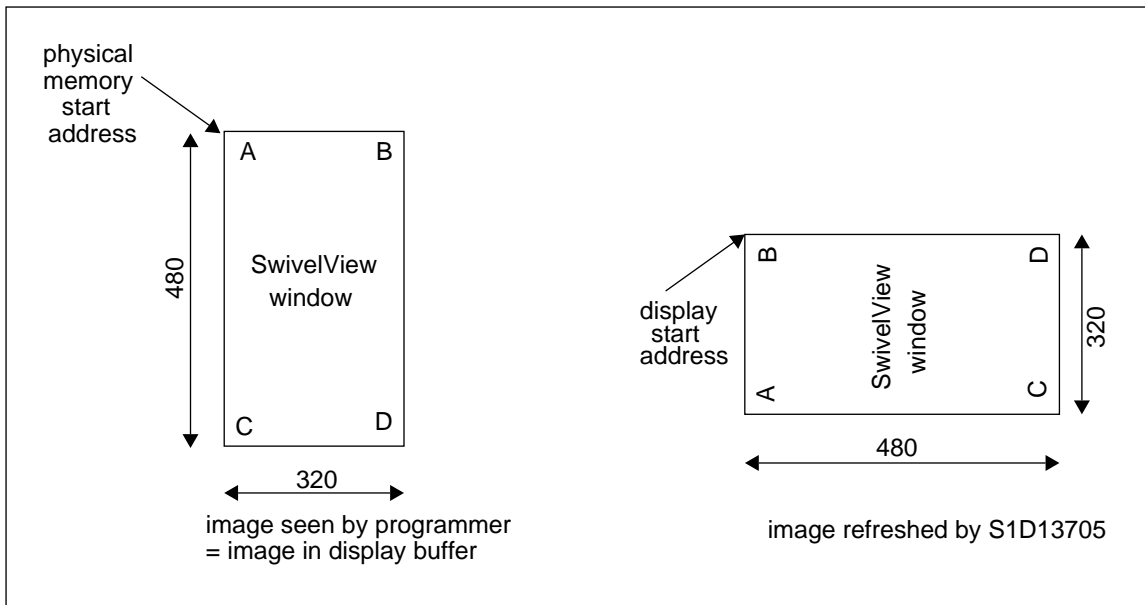

Figure 12-2 Relationship Between The Screen Image and the Image Refreshed by S1D13705 in Alternate Mode

12.2.1 How to Set Up Alternate SwivelView Mode

The following describes the register settings needed to set up Alternate SwivelView Mode for a 320×480×4 bpp image.

- Select Alternate SwivelView Mode:
REG[1Bh] bit 7 = 1 and bit 6 = 1
- The display refresh circuitry starts at pixel “B”, therefore the Screen 1 Start Address register must be programmed with the address of pixel “B”, or

$$\begin{aligned} \text{REG}[10\text{h}], \text{REG}[0\text{Dh}], \text{REG}[0\text{Ch}] &= \text{Address Of Pixel B} \\ &= (\text{Address Of Pixel A} + \text{Byte Offset}) \\ &= \text{Address Of Pixel A} + \left(\frac{320 \text{ pixels} \times 4 \text{ bpp}}{8 \text{ bpb}} \right) - 1 \\ &= \text{Address Of Pixel A} + 9\text{Fh} \end{aligned}$$

Where bpb is bits-per-pixel and bpb is bits-per-byte.

- The Line Byte Count Register for SwivelView Mode must be set to the image width in bytes, i.e.

$$\text{REG}[1\text{Ch}] = \frac{320}{(8\text{bpb}) \div (4\text{bpp})} = \frac{320}{2} = 160 = \text{A0h}$$

Where bpb is bits-per-byte and bpp is bits-per-pixel.

- Panning is achieved by changing the Screen 1 Start Address register:
- Increment the register by 1 to pan horizontally by one byte, e.g. two pixels in 4 bpp mode
- Increment the register by the value in the Line Byte Count register to pan vertically by one line, e.g. add A0h to pan by one line in the example above

12.3 Comparison Between Default and Alternate SwivelView Modes

Table 12-1 Default and Alternate SwivelView Mode Comparison

Item	Default SwivelView Mode	Alternate SwivelView Mode
Memory Requirements	The width of the rotated image must be a power of 2. In most cases, a virtual image is required where the right-hand side of the virtual image is unused and memory is wasted. For example, a $320 \times 480 \times 4\text{bpp}$ image would normally require only 76,800 bytes - possible within the 80K byte address space, but the virtual image is $512 \times 480 \times 4\text{bpp}$ which needs 122,880 bytes - not possible.	Does not require a virtual image.
Clock Requirements	CLK need only be as fast as the required PCLK.	MCLK, and hence CLK, need to be 2x PCLK. For example, if the panel requires a 3MHz PCLK, then CLK must be 6MHz. Note that 25MHz is the maximum CLK, so PCLK cannot be higher than 12.5MHz in this mode.
Power Consumption	Lowest power consumption.	Higher than Default Mode.
Panning	Vertical panning in 2 line increments.	Vertical panning in 1 line increments.
Performance	Nominal performance.	Higher performance than Default Mode.

12.4 SwivelView Mode Limitations

The only limitation to using SwivelView mode on the S1D13705 is that split screen operation is not supported.

13 POWER SAVE MODES

Two Power Save Modes have been incorporated into the S1D13705 to accommodate the need for power reduction in the hand-held devices market. These modes are enabled as follows:

Table 13-1 Power Save Mode Selection

Hardware Power Save	Software Power Save Bit 1	Software Power Save Bit 0	Mode
Not Configured or 0	0	0	Software Power Save Mode
Not Configured or 0	0	1	reserved
Not Configured or 0	1	0	reserved
Not Configured or 0	1	1	Normal Operation
Configured and 1	X	X	Hardware Power Save Mode

13.1 Software Power Save Mode

Software Power Save Mode saves power by powering down the panel and stopping display refresh accesses to the display buffer.

Table 13-2 Software Power Save Mode Summary

• Registers read/write accessible
• Memory read/write accessible
• Look-Up Table registers not accessible
• LCD outputs are forced low

13.2 Hardware Power Save Mode

Hardware Power Save Mode saves power by powering down the panel, stopping accesses to the display buffer and registers, and disabling the Host Bus Interface.

Table 13-3 Hardware Power Save Mode Summary

• Host Interface not accessible
• Memory read/write not accessible
• Look-Up Table registers not accessible
• LCD outputs are forced low

13.3 Power Save Mode Function Summary

Table 13-4 Power Save Mode Function Summary

	Hardware Power Save	Software Power Save	Normal
IO Access Possible?	No	Yes	Yes
Memory Access Possible?	No	Yes	Yes
Look-Up Table Registers Access Possible?	No	No	Yes
Sequence Controller Running?	No	No	Yes
Display Active?	No	No	Yes
LCDPWR	Inactive	Inactive	Active
FPDAT[11:0], FPSHIFT (see note)	Forced Low	Forced Low	Active
FPLINE, FPFRAME, DRDY	Forced Low	Forced Low	Active

Note: When FPDAT[11:8] are designated as GPIO these pins are not forced low. Unused GPIO pins must be tied to IO V_{DD} - see Table 5-8, "LCD Interface Pin Mapping," on page 1-14.

13.4 Panel Power Up/Down Sequence

After chip reset or when entering/exiting a power save mode, the Panel Interface signals follow a power on/off sequence shown below. This sequence is essential to prevent damage to the LCD panel.

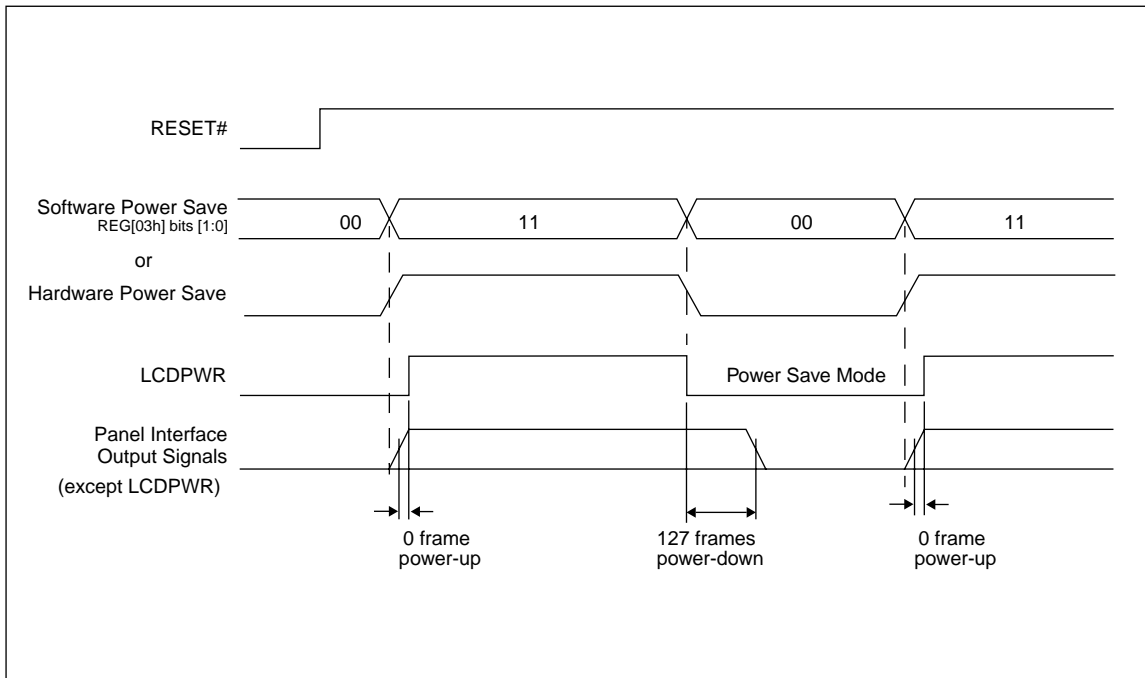

Figure 13-1 Panel On/Off Sequence

After chip reset, LCDPWR is inactive and the rest of the panel interface output signals are held “low”. Software initializes the chip (i.e. programs all registers except the Look-Up Table registers) and then programs REG[03h] bits [1:0] to 11b. This starts the power-up sequence as shown. The power-up/power-down sequence delay is 127 frames. The Look-Up Table registers may be programmed any time after REG[03h] bits[1:0] = 11b.

The power-up/power-down sequence also occurs when exiting/entering Software Power Save Mode.

13.5 Turning Off BCLK Between Accesses

BCLK may be turned off (held low) between accesses if the following rules are observed:

1. BCLK must be turned off/on in a glitch free manner
2. BCLK must continue for a period equal to $[8T_{BCLK} + 12T_{MCLK}]$ after the end of the access (RDY# asserted or WAIT# deasserted).
3. BCLK must be present for at least one T_{BCLK} before the start of an access.

13.6 Clock Requirements

The following table shows what clock is required for which function in the S1D13705.

Table 13-5 S1D13705 Internal Clock Requirements

Function	BCLK	CLKI
Register Read/Write	Is required during register accesses. BCLK can be shut down between accesses: allow eight BCLK pulses plus 12 MCLK pulses ($8T_{BCLK} + 12T_{MCLK}$) after the last access before shutting BCLK off. Allow one BCLK pulse after starting up BCLK before the next access.	Not Required
Memory Read/Write	Is required during memory accesses. BCLK can be shut down between accesses: allow eight BCLK pulses plus 12 MCLK pulses ($8T_{BCLK} + 12T_{MCLK}$) after the last access before shutting BCLK off. Allow one BCLK pulse after starting up BCLK before the next access.	Required
Look-Up Table Register Read/Write	Is required during LUT register accesses. BCLK can be shut down between accesses: allow eight BCLK pulses plus 12 MCLK pulses ($8T_{BCLK} + 12 T_{MCLK}$) after the last access before shutting BCLK off. Allow one BCLK pulse after starting up BCLK before the next access.	Not Required
Software Power Save	Required	Can be stopped after 128 frames from entering Software Power Save, i.e. after REG[03h] bits 1-0 = 11.
Hardware Power Save	Not Required	Can be stopped after 128 frames from entering Hardware Power Save.

14 MECHANICAL DATA

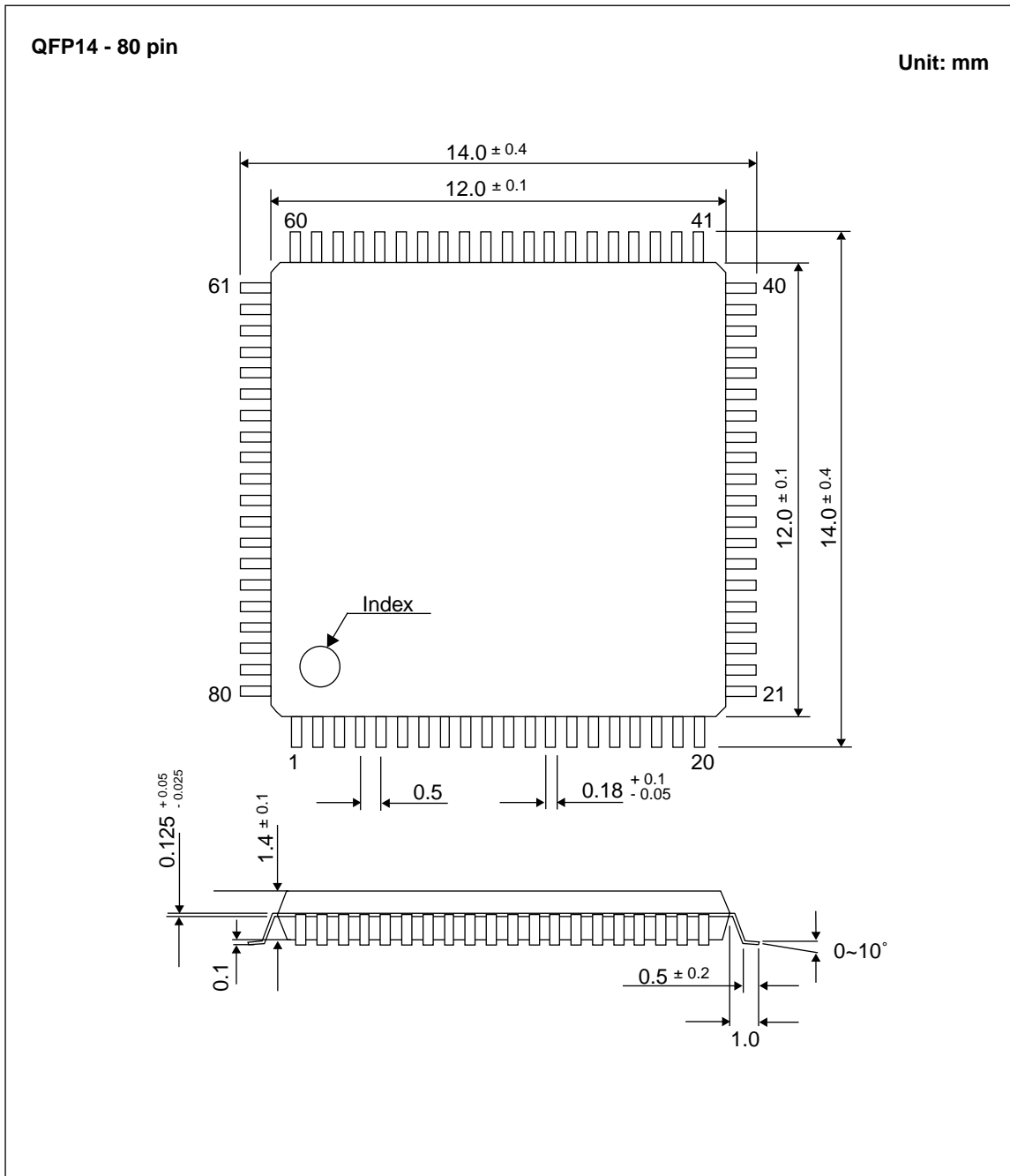

Figure 14-1 Mechanical Drawing QFP14

S1D13705F00A
Embedded Memory LCD Controller

**Programming Notes
and Examples**

1	INTRODUCTION	2-1
2	INITIALIZATION.....	2-2
2.1	Display Buffer Location	2-2
2.2	Register Values	2-2
2.3	Frame Rate Calculation.....	2-3
3	MEMORY MODELS.....	2-5
3.1	1 Bit-Per-Pixel (2 Colors/Gray Shades).....	2-5
3.2	2 Bit-Per-Pixel (4 Colors/Gray Shades).....	2-5
3.3	4 Bit-Per-Pixel (16 Colors/Gray Shades).....	2-6
3.4	Eight Bit-Per-Pixel (256 Colors).....	2-6
4	LOOK-UP TABLE (LUT)	2-7
4.1	Look-Up Table Registers.....	2-8
4.2	Look-Up Table Organization	2-8
	Color Modes.....	2-8
	Gray Shade Modes	2-12
5	ADVANCED TECHNIQUES.....	2-15
5.1	Virtual Display	2-15
	Registers	2-15
	Examples	2-16
5.2	Panning and Scrolling	2-16
	Registers	2-17
	Examples	2-18
5.3	Split Screen	2-20
	Registers.....	2-20
	Examples	2-22
6	LCD POWER SEQUENCING AND POWER SAVE MODES.....	2-23
6.1	LCD Power Sequencing	2-23
6.2	Registers	2-23
6.3	LCD Enable/Disable	2-24
7	HARDWARE ROTATION.....	2-25
7.1	Introduction To Hardware Rotation	2-25
7.2	Default Portrait Mode	2-25
7.3	Alternate Portrait Mode	2-26
7.4	Registers	2-27
7.5	Limitations	2-28
7.6	Examples.....	2-28
8	IDENTIFYING THE S1D13705	2-31
9	HARDWARE ABSTRACTION LAYER (HAL).....	2-32
9.1	Introduction.....	2-32
9.2	Contents of the HAL_STRUCT	2-32
9.3	Using the HAL library	2-32
9.4	API for 13705HAL	2-33
	Initialization	2-34
	General HAL Support.....	2-35
	Advanced HAL Functions	2-37
	Register / Memory Access	2-40
	Power Save.....	2-41
	Drawing	2-42
	LUT Manipulation	2-43
9.5	Porting LIBSE to a new target platform	2-44
	Building the LIBSE library for SH3 target example	2-44

Building the HAL library for the target example	2-45
10 SAMPLE CODE	2-46
10.1 Sample code using the S1D13705 HAL API	2-46
10.2 Sample code without using the S1D13705 HAL API	2-48
10.3 Header Files	2-54

List of Figures

Figure 3-1	Pixel Storage for 1 Bpp (2 Colors/Gray Shades) in One Byte of Display Buffer	2-5
Figure 3-2	Pixel Storage for 2 Bpp (4 Colors/Gray Shades) in One Byte of Display Buffer	2-5
Figure 3-3	Pixel Storage for 4 Bpp (16 Colors/Gray Shades) in One Byte of Display Buffer	2-6
Figure 3-4	Pixel Storage for 8 Bpp (256 Colors) in One Byte of Display Buffer	2-6
Figure 5-1	Viewport Inside a Virtual Display	2-15
Figure 5-2	320×240 Single Panel For Split Screen	2-20
Figure 7-1	Relationship Between the Default Mode Screen Image and the Image Refreshed by S1D13705	2-25
Figure 7-2	Relationship Between the Alternate Mode Screen Image and the Image Refreshed by S1D13705	2-26

List of Tables

Table 2-1	S1D13705 Initialization Sequence	2-3
Table 4-1	Recommended LUT Values for 1 Bpp Color Mode	2-8
Table 4-2	Example LUT Values for 2 Bpp Color Mode	2-9
Table 4-3	Suggested LUT Values to Simulate VGA Default 16 Color Palette.....	2-10
Table 4-4	Suggested LUT Values to Simulate VGA Default 256 Color Palette.....	2-11
Table 4-5	Recommended LUT Values for 1 Bpp Gray Shade	2-12
Table 4-6	Suggested Values for 2 Bpp Gray Shade	2-13
Table 4-7	Suggested LUT Values for 4 Bpp Gray Shade.....	2-14
Table 5-1	Number of Pixels Panned Using Start Address.....	2-17
Table 7-1	Default and Alternate Portrait Mode Comparison.....	2-28
Table 9-1	HAL Functions.....	2-33

1 INTRODUCTION

This guide demonstrates how to program the S1D13705 Embedded Memory Color LCD Controller. The guide presents the basic concepts of the LCD controller and provides methods to directly program the registers. It explains some of the advanced techniques used and the special features of the S1D13705.

The guide also introduces the Hardware Abstraction Layer (HAL), which is designed to make programming the S1D13705 as easy as possible. Future S1D1370x products will support the HAL allowing OEMs the ability to upgrade to future chips with relative ease.

2 *INITIALIZATION*

Prior to doing anything else with the S1D13705 the controller must be initialized. Initialization is the process of setting up the control registers to a known state in order to generate proper display signals.

2.1 *Display Buffer Location*

Before we can perform the initialization we have to know where to find the S1D13705 display memory and control registers.

The S1D13705 contains 80 kilobytes of internal display memory. External support logic must be employed to decode the starting address for this display memory in CPU address space. On the S5U13705B00C PC platform evaluation boards the address is usually fixed at F00000h. Alternatively the address can be set to D0000h.

The control registers are located by adding 1FFE0h (128 Kb less 32 bytes) to the base memory address. Thus, on the typical PC platform, we access control register 0 at address F1FFE0h. Control register 5 would be located at address F1FFE5, etc.

2.2 *Register Values*

This section describes the register settings and sequence of setting the registers. In addition to these setting the Look-Up Table must be programmed with appropriate colors. Look-Up Table setup is not covered here. See “Section” 4 on page 2-7 of this manual for Look-Up Table programming details.

The following initialization, presented in table form, shows the sequences and values to set the registers. The notes column comments the reason for the particular value being written.

This example writes to all the necessary registers. Initially, when the S1D13705 is powered up, all registers, unless noted otherwise in the specification, are set to zero. This example programs these registers to zero to establish a known state. In practice, it may be possible to write to only a subset of the registers.

The example initializes a S1D13705 to control a panel with the following specifications:

- 320 × 240 color single passive LCD panel at 70Hz.
- Color Format 2, 8-bit data interface.
- 8 bit-per-pixel (256 colors).
- 6 MHz input clock (CLKI).

Table 2-1 S1D13705 Initialization Sequence

Register	Value (hex)	Notes	See Also
[01]	0010 0011 (23)	Select a passive, Single, Color panel with an 8-bit data width	
[02]	1100 0000 (C0)	Select 8-bit per pixel color depth	
[03]	0000 0011 (03)	Select normal power operation	
[04]	0010 0111 (27)	Horizontal display size = $(\text{Reg}[04]+1)*8 = (39+1) * 8 = 320$ pixels	
[05]	1110 1111 (EF)	Vertical display size = $\text{Reg}[06][05] + 1$	
[06]	0000 0000 (00)	= $0000 0000 1110 1111 + 1 = 239 + 1 = 240$ lines	
[07]	0000 0000 (00)	FPLINE start position (only required for TFT configuration)	
[08]	0000 0000 (00)	Horizontal non-display period = $(\text{Reg}[08] + 4) * 8$ = $4 * 8 = 32$ pixels	Frame Rate Calculation
[09]	0000 0000 (00)	FPPFRAME start position (only required for TFT configuration)	
[0A]	0000 0011 (03)	Vertical non-display period = $\text{REG}[0A] = 3$ lines	Frame Rate Calculation
[0B]	0000 0000 (00)	MOD rate is only required by some monochrome panels	
[0C]	0000 0000 (00)	Screen 1 Start Address - set to 0 for initialization	"5.3 Split Screen" on page 2-20
[0D]	0000 0000 (00)		
[0E]	0000 0000 (00)	Screen 2 Start Address - set to 0 for initialization	"5.3 Split Screen" on page 2-20
[0F]	0000 0000 (00)		
[10]	0000 0000 (00)	Screen 1 / Screen 2 Start Address MSB - set to 0	
[11]	0000 0000 (00)	Memory Address offset - not virtual setup - so set to 0	"5.1 Virtual Display" on page 2-15
[12]	1111 1111 (FF)	Set the vertical size to the maximum value.	"5.3 Split Screen" on page 2-20
[13]	0000 0011 (03)		
[15]		Leave the LUT alone for now	"4 Look-Up Table (LUT)" on page 2-7
[17]			
[18]	0000 0000 (00)	GPIO control and status registers - set to "0".	
[19]	0000 0000 (00)		
[1A]	0000 0000 (00)		
[1B]	0000 0000 (00)	This is not portrait mode so set this register to "0".	"7.1 Introduction To Hardware Rotation" on page 2-25
[1C]	0000 0000 (00)	Line Byte Count is only required for portrait mode.	

2.3 Frame Rate Calculation

Frame rate specifies the number of complete frame which are drawn on the display in one second. Configuring a frame rate that is too high or too low adversely effects the quality of the displayed image.

System configuration imposes certain non-variable limitations. For instance the width and height of the display panel are fixed as is, typically, the input clock to the S1D13705. From the following formula it is evident that the two variables the programmer can use to adjust frame rate are horizontal and vertical non-display periods.

The following are the formulae for determining the frame rate of a panel. The formula for a single passive or TFT panel is calculated as follows:

$$\text{FrameRate} = \frac{\text{PCLK}}{(\text{HDP} + \text{HNDP}) \times (\text{VDP} + \text{VNDP})}$$

for a dual passive panel the formula is:

$$\text{FrameRate} = \frac{\text{PCLK}}{2 \times (\text{HDP} + \text{HNDP}) \times \left(\frac{\text{VDP}}{2} + \text{VNDP}\right)}$$

where :

- PCLK = Pixel clock (in Hz)
- HDP = Horizontal Display Period (in pixels)
- HNDP = Horizontal Non-Display Period (in pixels)
- VDP = Vertical Display Period (in lines)
- VNDP = Vertical Non-Display Period (in lines)

In addition to varying the HNDP and VNDP times we can also select divider values which will reduce CLK_i to one half, one quarter up to one eighth of the CLK_i value. The example below is a portion of a 'C' routine to calculate HNDP and VNDP from a desired frame rate.

```
for (int loop = 0; loop < 2; loop++)
{
    for (VNDP = 2; VNDP < 0x3F; VNDP += 3)
    {
        // Solve for HNDP
        HNDP = (PCLK / (FrameRate * (VDP + VNDP))) - HDP;
        if ((HNDP >= 32) && (HNDP <= 280))
        {
            // Solve for VNDP.
            VNDP = (PCLK / (FrameRate * (HDP + HNDP))) - VDP;
            // If we have satisfied VNDP then we're done.
            if ((VNDP >= 0) && (VNDP <= 0x3F))
                goto DoneCalc;
        }
    }
    // Divide ClkI and try again.
    // (Reg[02] allows us to dived CLKI by 2)
    PCLK /= 2;
}
// If we still can't hit the frame rate - throw an error.
if ((VNDP < 0) || (VNDP > 0x3F) || (HNDP < 32) || (HNDP > 280))
{
    printf("ERROR: Unable to set the desired frame rate.\n");
    exit(1);
}
```

This routine first performs a formula rearrangement so that HNDP or VNDP can be solved. Start with VNDP set to a small value. Loop increasing VNDP and solving the equation for HNDP until satisfactory HNDP and VNDP values are found. If no satisfactory values are found then divide CLK_i and repeat the process. If a satisfactory frame rate still can't be reached - return an error.

Note: Most passive (STN) panels are tolerant of nearly any combination of HNDP and VNDP values, however panel specifications generally specify only a few lines of vertical non-display period. The S1D13705 is capable of generating a vertical non-display period of up to sixty-three lines. This amount of VNDP is far too great a non-display period and will likely degrade display quality. Similarly, setting a large HNDP value may cause a degrade in image quality.

If possible the system should be designed such that VNDP values of 7 or less lines and HNDP values of 20 or less characters can be selected.

3 MEMORY MODELS

The S1D13705 is capable of operating at four different color depths. For each color depth the data format is packed pixel. S1D13705 packed pixel modes can range from one byte containing eight adjacent pixels (1-bpp) to one byte containing just one pixel (8-bpp).

Packed pixel data may be envisioned as a stream of pixels. In this stream, pixels are packed in adjacent to each other. If a pixel requires four bits then it will be located in the four most significant bits of a byte. The pixel to the immediate right on the display will occupy the lower four bits of the same byte. The next two pixels to the immediate right are located in the following byte, etc.

3.1 1 Bit-Per-Pixel (2 Colors/Gray Shades)

1-bit pixels support two color/gray shades. In this memory format each byte of display buffer contains eight adjacent pixels. Setting or resetting any pixel requires reading the entire byte, masking out appropriate bits and, if necessary, setting bits to “1”.

When using a color panel the two colors are derived by indexing into positions 0 and 1 of the Look-Up Table. If the first two LUT elements are set to black (RGB = 0 0 0) and white (RGB = F F F) then each “0” bit of display memory will display as a black pixel and each “1” bit will display as a white pixel. The two LUT entries can be set to any desired colors, for instance red and green or cyan and yellow.

For monochrome panels the two displayed gray shades are generated by indexing into the first two elements of the green component of the Look-Up Table (LUT). Thus, by manipulating the green LUT components we can set either of the two gray shades to any of sixteen possible levels.

Bit 7	Bit 6	Bit 5	Bit 4	Bit 3	Bit 2	Bit 1	Bit 0
Pixel 0	Pixel 1	Pixel 2	Pixel 3	Pixel 4	Pixel 5	Pixel 6	Pixel 7

Figure 3-1 Pixel Storage for 1 Bpp (2 Colors/Gray Shades) in One Byte of Display Buffer

3.2 2 Bit-Per-Pixel (4 Colors/Gray Shades)

2-bit pixels support four color/gray shades. In this memory format each byte of display buffer contains four adjacent pixels. Setting or resetting any pixel requires reading the entire byte, masking out the appropriate bits and, if necessary, setting bits to “1”.

Color panels derive their four colors by indexing into positions 0 through 3 of the Look-Up Table. These four LUT entries can be set to any of the 4096 possible color combinations.

Monochrome panels derive four gray shades by indexing into the first four elements of the green component of the Look-Up Table. Any of the four LUT entries can be set to any of the sixteen possible gray shades.

Bit 7	Bit 6	Bit 5	Bit 4	Bit 3	Bit 2	Bit 1	Bit 0
Pixel 0 Bit 1	Pixel 0 Bit 0	Pixel 1 Bit 1	Pixel 1 Bit 0	Pixel 2 Bit 1	Pixel 2 Bit 0	Pixel 3 Bit 1	Pixel 3 Bit 0

Figure 3-2 Pixel Storage for 2 Bpp (4 Colors/Gray Shades) in One Byte of Display Buffer

3.3 4 Bit-Per-Pixel (16 Colors/Gray Shades)

Four bit pixels support 16 color/gray shades. In this memory format each byte of display buffer contains two adjacent pixels. Setting or resetting any pixel requires reading the entire byte, masking out the upper or lower nibble (4 bits) and setting the appropriate bits to “1”.

Color panels can display up to sixteen colors simultaneously. These sixteen colors are derived by indexing into the first sixteen elements of the Look-Up Table. Each of these colors may be selected from the 4096 possible available colors.

On a monochrome panel the gray shades are generated by indexing into the first sixteen green components of the LUT. Each of these sixteen possible gray shades can be adjusted to any of the sixteen possible gray shades. For instance, one could program the first eight green LUT entries to be 0 and the second green LUT entries to be FFh. This would result in nibble values of 0 through 7 displaying as black and nibble values 8 through 0Fh displaying as white.

Bit 7	Bit 6	Bit 5	Bit 4	Bit 3	Bit 2	Bit 1	Bit 0
Pixel 0 Bit 3	Pixel 0 Bit 2	Pixel 0 Bit 1	Pixel 0 Bit 0	Pixel 1 Bit 3	Pixel 1 Bit 2	Pixel 1 Bit 1	Pixel 1 Bit 0

Figure 3-3 Pixel Storage for 4 Bpp (16 Colors/Gray Shades) in One Byte of Display Buffer

3.4 Eight Bit-Per-Pixel (256 Colors)

In eight bit-per-pixel mode one byte of display buffer represents one pixel on the display. At this color depth the read-modify-write cycles, required by the lessor pixel depths, are eliminated.

When using a color panel, each byte of display memory acts as an index to one element of the LUT. The displayed color is arrived at by taking the display memory value as an index into the LUT.

Eight bit per pixel is not supported for monochrome display modes. The reason is that each element of the LUT supports a 4-bit (sixteen value) level for red, green and blue. In monochrome display modes on the green value is used to set the gray intensity. Thus we have sixteen possible grey values but, because of the color.

Bit 7	Bit 6	Bit 5	Bit 4	Bit 3	Bit 2	Bit 1	Bit 0
Red bit 2	Red bit 1	Red bit 0	Green bit 2	Green bit 1	Green bit 0	Blue bit 1	Blue bit 0

Figure 3-4 Pixel Storage for 8 Bpp (256 Colors) in One Byte of Display Buffer

4 LOOK-UP TABLE (LUT)

This section is supplemental to the description of the Look-Up Table architecture found in the S1D13705 Hardware Functional Specification. Covered here is a review of the LUT registers, recommendations for the color and gray shade LUT values, and additional programming considerations for the LUT. Refer to the “*S1D13705 Hardware Functional Specification*”, document number X27A-A-001-01 for more detail.

The S1D13705 Look-Up Table consists of 256 indexed red/green/blue entries. Each entry is 4 bits wide. Two registers, REG[15h] and REG[17h], control access to the LUT.

Each Look-Up Table entry consists of a red, green, and blue component. Each component consisting of four bits, or sixteen intensity levels. Any Look-Up Table element can be selected from a palette of 4096 (16×16×16) colors.

In color display modes, pixel values are used as an index to an RGB value stored in the Look-Up Table. In monochrome modes, pixel values still index into the LUT, but only the green component is used to determine display intensity.

The selected color depth determines how many index positions are used for image display. For example at one bit-per-pixel (bpp) only index positions 0 and 1 of the Look-Up Table are used. At 4-bpp the first 16 index positions of the Look-Up Table are used and at 8-bpp all 256 Look-Up Table index positions are used.

The Look-Up Table mechanism itself consists of an index register and a data register. The index, or address, register determines which element of the Look-Up Table will be accessed. After setting the index the LUT may be read or written through the data register. The first data element read or written is the red component of the entry. Subsequent read/write operations access the green and then the blue elements of the Look-Up Table. The S1D13705 LUT architecture is designed to provide a high degree of similarity in operation to a standard VGA RAMDAC. However, there are two considerations which must be kept in mind.

- The S1D13705 Look-Up Table has four bits (16 levels) of intensity per primary color. The standard VGA RAMDAC has six bits (64 levels). This four to one difference must be taken into consideration when converting from a VGA palette to a LUT palette. One suggestion is to divide the VGA intensity level by four to arrive at the LUT intensity.

However, most applications specify the red, green and blue components as eight bit intensities. To determine the appropriate S1D13705 Look-Up Table value we recommend using the four most significant bits.

4.1 Look-Up Table Registers

REG[15h] Look-Up Table Address Register							Read/Write
LUT Address Bit 7	LUT Address Bit 6	LUT Address Bit 5	LUT Address Bit 4	LUT Address Bit 3	LUT Address Bit 2	LUT Address Bit 1	LUT Address Bit 0

LUT Address

The LUT address register selects which of the 256 LUT entries will be accessed. After three successive reads/writes to the data register this register is automatically incremented to point to the next address.

REG[17h] Look-Up Table Data Register							Read/Write
LUT Data Bit 3	LUT Data Bit 2	LUT Data Bit 1	LUT Data Bit 0	n/a	n/a	n/a	n/a

LUT Data

This register is where the 4-bit red/green/blue data value is written/read. Immediately after setting the LUT index with register [15h] this register accesses the red element of the Look-Up Table. With each successive write/read the internal bank select is incremented. Thus the second access is from the green element and the third is from the blue element.

After the third access the LUT Address is incremented by one, then next access to this register will be the red element of the next Look-Up Table index.

4.2 Look-Up Table Organization

Color Modes

1 bpp color

When the S1D13705 is configured for 1 bpp color mode, the LUT is limited to selecting colors from the first two entries. The two LUT entries can be any two RGB values but are typically set to black-and-white.

Each byte in the display buffer contains eight adjacent pixels. If a bit has a value of “0” then the color in LUT 0 index is displayed. A bit value of “1” results in the color in LUT 1 index being displayed.

The following table shows the recommended values for obtaining a black-and-white mode while in 1 bpp on a color panel.

Table 4-1 Recommended LUT Values for 1 Bpp Color Mode

Index	Red	Green	Blue
00	00	00	00
01	F0	F0	F0
02	00	00	00
...	00	00	00
FF	00	00	00

 unused entries

2 bpp color

When the S1D13705 is configured for 2 bpp color mode, the displayed colors are selected from the first four entries of the Look-Up Table. The LUT entries may be set to any of the 4096 possible colors.

Each byte in the display buffer contains four adjacent pixels. If a bit combination has a value of “00” then the color in LUT index 0 is displayed. A bit value of “01” results in the color in LUT index 1 being displayed. Likewise the bit combination of “10” displays from the third LUT entry and “11” displays a color from the fourth LUT entry.

The following table shows the example values for 2 bit-per-pixel display mode.

Table 4-2 Example LUT Values for 2 Bpp Color Mode

Index	Red	Green	Blue
00	00	00	00
01	70	70	70
02	A0	A0	A0
03	F0	F0	F0
04	00	00	00
...	00	00	00
FF	00	00	00

 indicates unused entries

4 bpp color

When the S1D13705 is configured for 4 bpp color mode, the displayed colors are selected from the first sixteen entries of the Look-Up Table. The LUT entries may be set to any of the 4096 possible colors.

Each byte in the display buffer contains two adjacent pixels. If a nibble has a value of “0000” then the color in LUT index 0 is displayed. A nibble value of “0001” results in the color in LUT index 1 being displayed. The pattern continues to the nibble pattern of “1111” which results in the sixteenth color of the Look-Up Table being displayed.

The following table shows the example values for 4 bit-per-pixel display mode. These colors simulate the colors used by the sixteen color modes of a VGA.

Table 4-3 Suggested LUT Values to Simulate VGA Default 16 Color Palette

Index	Red	Green	Blue
00	00	00	00
01	00	00	A0
02	00	A0	00
03	00	A0	A0
04	A0	00	00
05	A0	00	A0
06	A0	A0	00
07	A0	A0	A0
08	00	00	00
09	00	00	F0
0A	00	F0	00
0B	00	F0	F0
0C	F0	00	00
0D	F0	00	F0
0E	F0	F0	00
0F	F0	F0	F0
10	00	00	00
...	00	00	00
FF	00	00	00

 indicates unused entries

8 bpp color

When the S1D13705 is configured for 8 bpp color mode the entire Look-Up Table is used to display images. Each of the LUT entries may be set to any of the 4096 possible colors.

Each byte in the display buffer represents one pixels. The byte value is used directly as an index into one of the 256 LUT entries. A display memory byte with a value of 00h will display the color contained in the first Look-Up Table entry while a display memory byte of FFh will display a color formed by the two hundred and fifty sixth Look-Up Table entry.

The following table depicts LUT values which approximate the VGA default 256 color palette.

Table 4-4 Suggested LUT Values to Simulate VGA Default 256 Color Palette

Index	R	G	B	Index	R	G	B	Index	R	G	B	Index	R	G	B
00	00	00	00	40	F0	70	70	80	30	30	70	C0	00	40	00
01	00	00	A0	41	F0	90	70	81	40	30	70	C1	00	40	10
02	00	A0	00	42	F0	B0	70	82	50	30	70	C2	00	40	20
03	00	A0	A0	43	F0	D0	70	83	60	30	70	C3	00	40	30
04	A0	00	00	44	F0	F0	70	84	70	30	70	C4	00	40	40
05	A0	00	A0	45	D0	F0	70	85	70	30	60	C5	00	30	40
06	A0	50	00	46	B0	F0	70	86	70	30	50	C6	00	20	40
07	A0	A0	A0	47	90	F0	70	87	70	30	40	C7	00	10	40
08	50	50	50	48	70	F0	70	88	70	30	30	C8	20	20	40
09	50	50	F0	49	70	F0	90	89	70	40	30	C9	20	20	40
0A	50	F0	50	4A	70	F0	B0	8A	70	50	30	CA	30	20	40
0B	50	F0	F0	4B	70	F0	D0	8B	70	60	30	CB	30	20	40
0C	F0	50	50	4C	70	F0	F0	8C	70	70	30	CC	40	20	40
0D	F0	50	F0	4D	70	D0	F0	8D	60	70	30	CD	40	20	30
0E	F0	F0	50	4E	70	B0	F0	8E	50	70	30	CE	40	20	30
0F	F0	F0	F0	4F	70	90	F0	8F	40	70	30	CF	40	20	20
10	00	00	00	50	B0	B0	F0	90	30	70	30	D0	40	20	20
11	10	10	10	51	C0	B0	F0	91	30	70	40	D1	40	20	20
12	20	20	20	52	D0	B0	F0	92	30	70	50	D2	40	30	20
13	20	20	20	53	E0	B0	F0	93	30	70	60	D3	40	30	20
14	30	30	30	54	F0	B0	F0	94	30	70	70	D4	40	40	20
15	40	40	40	55	F0	B0	E0	95	30	60	70	D5	30	40	20
16	50	50	50	56	F0	B0	D0	96	30	50	70	D6	30	40	20
17	60	60	60	57	F0	B0	C0	97	30	40	70	D7	20	40	20
18	70	70	70	58	F0	B0	B0	98	50	50	70	D8	20	40	20
19	80	80	80	59	F0	C0	B0	99	50	50	70	D9	20	40	20
1A	90	90	90	5A	F0	D0	B0	9A	60	50	70	DA	20	40	30
1B	A0	A0	A0	5B	F0	E0	B0	9B	60	50	70	DB	20	40	30
1C	B0	B0	B0	5C	F0	F0	B0	9C	70	50	70	DC	20	40	40
1D	C0	C0	C0	5D	E0	F0	B0	9D	70	50	60	DD	20	30	40
1E	E0	E0	E0	5E	D0	F0	B0	9E	70	50	60	DE	20	30	40
1F	F0	F0	F0	5F	C0	F0	B0	9F	70	50	50	DF	20	20	40
20	00	00	F0	60	B0	F0	B0	A0	70	50	50	E0	20	20	40
21	40	00	F0	61	B0	F0	C0	A1	70	50	50	E1	30	20	40
22	70	00	F0	62	B0	F0	D0	A2	70	60	50	E2	30	20	40
23	B0	00	F0	63	B0	F0	E0	A3	70	60	50	E3	30	20	40
24	F0	00	F0	64	B0	F0	F0	A4	70	70	50	E4	40	20	40
25	F0	00	B0	65	B0	E0	F0	A5	60	70	50	E5	40	20	30
26	F0	00	70	66	B0	D0	F0	A6	60	70	50	E6	40	20	30
27	F0	00	40	67	B0	C0	F0	A7	50	70	50	E7	40	20	30
28	F0	00	00	68	00	00	70	A8	50	70	50	E8	40	20	20
29	F0	40	00	69	10	00	70	A9	50	70	50	E9	40	30	20
2A	F0	70	00	6A	30	00	70	AA	50	70	60	EA	40	30	20
2B	F0	B0	00	6B	50	00	70	AB	50	70	60	EB	40	30	20
2C	F0	F0	00	6C	70	00	70	AC	50	70	70	EC	40	40	20

4: LOOK-UP TABLE (LUT)

Table 4-4 Suggested LUT Values to Simulate VGA Default 256 Color Palette (Continued)

Index	R	G	B	Index	R	G	B	Index	R	G	B	Index	R	G	B
2D	B0	F0	00	6D	70	00	50	AD	50	60	70	ED	30	40	20
2E	70	F0	00	6E	70	00	30	AE	50	60	70	EE	30	40	20
2F	40	F0	00	6F	70	00	10	AF	50	50	70	EF	30	40	20
30	00	F0	00	70	70	00	00	B0	00	00	40	F0	20	40	20
31	00	F0	40	71	70	10	00	B1	10	00	40	F1	20	40	30
32	00	F0	70	72	70	30	00	B2	20	00	40	F2	20	40	30
33	00	F0	B0	73	70	50	00	B3	30	00	40	F3	20	40	30
34	00	F0	F0	74	70	70	00	B4	40	00	40	F4	20	40	40
35	00	B0	F0	75	50	70	00	B5	40	00	30	F5	20	30	40
36	00	70	F0	76	30	70	00	B6	40	00	20	F6	20	30	40
37	00	40	F0	77	10	70	00	B7	40	00	10	F7	20	30	40
38	70	70	F0	78	00	70	00	B8	40	00	00	F8	00	00	00
39	90	70	F0	79	00	70	10	B9	40	10	00	F9	00	00	00
3A	B0	70	F0	7A	00	70	30	BA	40	20	00	FA	00	00	00
3B	D0	70	F0	7B	00	70	50	BB	40	30	00	FB	00	00	00
3C	F0	70	F0	7C	00	70	70	BC	40	40	00	FC	00	00	00
3D	F0	70	D0	7D	00	50	70	BD	30	40	00	FD	00	00	00
3E	F0	70	B0	7E	00	30	70	BE	20	40	00	FE	00	00	00
3F	F0	70	90	7F	00	10	70	BF	10	40	00	FF	00	00	00

Gray Shade Modes

Gray shade modes are monochrome display modes. Monochrome display modes use the Look-Up Table in a very similar fashion to the color modes. This most significant difference is that the monochrome display modes use only the intensity of the green element of the Look-Up Table to form the gray level.

One side effect of using only green for intensity selection is that in gray shade modes there are only sixteen possible intensities. 8 bit-per-pixel is not supported for gray shade modes.

1 bpp gray shade

When the S1D13705 is configured for 1 bpp gray shade mode, the LUT is limited to selecting colors from the first two green entries. The two LUT entries can be set to any of sixteen possible intensities. Typically they would be set to 0h (black) and Fh (white).

Each byte in the display buffer contains eight adjacent pixels. If a bit has a value of “0” then the color in the green LUT 0 index is displayed. A bit value of “1” results in the color in green LUT 1 index being displayed.

The following table shows the recommended values 1 bpp gray shade display mode

Table 4-5 Recommended LUT Values for 1 Bpp Gray Shade

Address	Red	Green	Blue
00	00	00	00
01	00	F0	00
02	00	00	00
...	00	00	00
FF	00	00	00

 unused entries

2 bpp gray shade

When the S1D13705 is configured for 2 bpp gray shade, the displayed colors are selected from the first four green entries in the Look-Up Table. The remaining entries of the LUT are unused. Each of the four entries can be set to any of the sixteen possible colors.

Each byte in the display buffer contains four adjacent pixels. If a bit combination has a value of “00” then the intensity in the green LUT index 0 is displayed. A bit value of “01” results in the intensity represented by the green in LUT index 1 being displayed. Likewise the bit combination of “10” displays from the third LUT entry and “11” displays a from the fourth LUT entry.

The following table shows the example values for 2 bit-per-pixel display mode.

Table 4-6 Suggested Values for 2 Bpp Gray Shade

Index	Red	Green	Blue
0	00	00	00
1	00	50	00
2	00	A0	00
3	00	F0	00
4	00	00	00
...	00	00	00
FF	00	00	00

 indicates unused entries

4 bpp gray shade

When the S1D13705 is configured for 4 bpp gray shade mode the displayed colors are selected from the green values of the first sixteen entries of the Look-Up Table. Each of the sixteen entries can be set to any of the sixteen possible intensity levels.

Each byte in the display buffer contains two adjacent pixels. If a nibble pattern is “0000” then the green intensity of LUT index 0 is displayed. A nibble value of “0001” results in the green intensity in LUT index 1 being displayed. The pattern continues to the nibble pattern of “1111” which results in the sixteenth intensity of Look-Up Table being displayed.

The following table shows the example values for 4 bit-per-pixel display mode.

Table 4-7 Suggested LUT Values for 4 Bpp Gray Shade

Index	Red	Green	Blue
00	00	00	00
01	00	10	00
02	00	20	00
03	00	30	00
04	00	40	00
05	00	50	00
06	00	60	00
07	00	70	00
08	00	80	00
09	00	90	00
0A	00	A0	00
0B	00	B0	00
0C	00	C0	00
0D	00	D0	00
0E	00	E0	00
0F	00	F0	00
10	00	00	00
...	00	00	00
FF	00	00	00

 indicates unused entries

5 ADVANCED TECHNIQUES

This section contains programming suggestions for the following:

- virtual display
- panning and scrolling
- split screen display

5.1 Virtual Display

Virtual display refers to the situation where the image to be viewed is larger than the physical display. The difference can be in the horizontal, vertical or both dimensions. To view the image, the display is used as a window into the display buffer. At any given time only a portion of the image is visible. Panning and scrolling are used to view the full image.

The Memory Address Offset register determines the number of horizontal pixels in the virtual image. The offset register can be used to specify from 0 to 255 additional words for each scan line. At 1 bpp, 255 words span an additional 4,080 pixels. At 8 bpp, 255 words span an additional 510 pixels.

The maximum vertical size of the virtual image is the result of dividing 81920 bytes of display memory by the number of bytes on each line (i.e. at 1 bpp with a 320×240 panel set for a virtual width of 640×480 there is enough memory for 1024 lines).

Figure 5-1 “Viewport Inside a Virtual Display,” depicts a typical use of a virtual display. The display panel is 320×240 pixels, an image of 640×480 pixels can be viewed by navigating a 320×240 pixel viewport around the image using panning and scrolling.

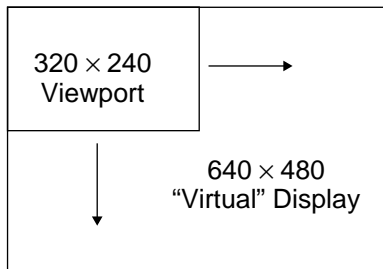

Figure 5-1 Viewport Inside a Virtual Display

Registers

REG[11h] Memory Address Offset Register							
Memory Address Offset	Memory Address Offset	Memory Address Offset	Memory Address Offset	Memory Address Offset	Memory Address Offset	Memory Address Offset	Memory Address Offset
Bit 7	Bit 6	Bit 5	Bit 4	Bit 3	Bit 2	Bit 1	Bit 0

Memory Address Offset Register

REG[11h] forms an 8-bit value called the Memory Address Offset. This offset is the number of additional words on each line of the display. If the offset is set to zero there is no virtual width.

This value does not represent the number of words to be shown on the display. The display width is set in the Horizontal Display Width register.

Note: This value does not represent the number of words to be shown on the display. The display width is set in the Horizontal Display Width register.

Examples

Example 1

In this example we go through the calculations to display a 640 × 480 image on a 320 × 240 panel at 2 bpp.

Step 1: Calculate the number of pixels per word for this color depth.

At 2 bpp each byte is comprised of 4 pixels, therefore each word contains 8 pixels.

$$\text{pixels_per_word} = 16 / \text{bpp} = 16 / 2 = 8$$

Step 2: Calculate the Memory Address Offset register value

We require a total of 640 pixels. The horizontal display register will account for 320 pixels, this leaves 320 pixels for the Memory Address Offset register to account for.

$$\text{offset} = \text{pixels} / \text{pixels_per_word} = 320 / 8 = 40 = 28\text{h}$$

The Memory Address Offset register, REG[11h], will have to be set to 28h to satisfy the above condition.

Example 2

From the above, what is the maximum number of lines our image can contain?

Step 1: Calculate the number of bytes on each line.

$$\text{bytes_per_line} = \text{pixels_per_line} / \text{pixels_per_byte} = 640 / 4 = 160$$

Each line of the display requires 160 bytes.

Step 2: Calculate the number of lines the S1D13705 is capable of.

$$\text{total_lines} = \text{memory} / \text{bytes_per_line} = 81920 / 160 = 512$$

We can display a maximum of 512 lines. Our example image requires 480 lines so this example can be done.

5.2 Panning and Scrolling

Panning and scrolling describe the operation of moving a physical display viewport about a virtual image in order to view the entire image a portion at time. For example, after setting up the previous example (virtual display) and drawing an image into it we would only be able to view one quarter of the image. Panning and scrolling are used to reveal the rest of the image.

Panning describes the horizontal (side to side) motion of the viewport. When panning to the right the image in the viewport appears to slide to the left. When panning to the left the image appears to slide to the right. Scrolling describes the vertical (up and down) motion of the viewport. Scrolling down causes the image to appear to slide up and scrolling up causes the image to appear to slide down.

Both panning and scrolling are performed by modifying the start address register. The start address registers in the S1D13705 are a word offset to the data to be displayed in the top left corner of a frame. Changing the start address by one means a change on the display of the number of pixels in one word. The number of pixels in word varies according to the color depth. At 1 bit-per-pixel a word contains sixteen pixels. At 2 bit-per-pixel there are eight pixels, at 4 bit-per-pixel there are four pixels and at 8 bit-per-pixel there is two pixels in each word. The number of pixels in each word represent the finest step we can pan to the left or right.

When portrait mode (see “7 Hardware Rotation” on page 2-25) is enabled the start address registers become offsets to bytes. In this mode the step rate for the start address registers is halved making for smoother panning.

Registers

REG[0Ch] Screen 1 Display Start Address 0 (LSB)							
Start Addr Bit 7	Start Addr Bit 6	Start Addr Bit 5	Start Addr Bit 4	Start Addr Bit 3	Start Addr Bit 2	Start Addr Bit 1	Start Addr Bit 0

REG[0Dh] Screen 1 Display Start Address 1 (MSB)							
Start Addr Bit 15	Start Addr Bit 14	Start Addr Bit 13	Start Addr Bit 12	Start Addr Bit 11	Start Addr Bit 10	Start Addr Bit 9	Start Addr Bit 8

REG[10h] Screen 1 Display Start Address 2 (MSB)							
n/a	n/a	n/a	n/a	n/a	n/a	n/a	Start Addr Bit 16

Screen 1 Start Address Registers

These three registers form the seventeen bit screen 1 start address. Screen 1 is displayed starting at the top left corner of the display.

In landscape mode these registers form the word offset to the first byte in display memory to be displayed in the upper left corner of the screen. Changing these registers by one will shift the display image 2 to 16 pixels, depending on the current color depth.

In portrait mode these registers form the offset to the display memory byte where screen 1 will start displaying. Changing these registers in portrait mode will result in a shift of 1 to 8 pixels depending on the color depth.

Refer to Table 5-1 to see the minimum number of pixels affected by a change of one to these registers

Table 5-1 Number of Pixels Panned Using Start Address

Color Depth (bpp)	Pixels per Word	Landscape Mode Number of Pixels Panned	Pixels Per Byte	Portrait Mode Number of Pixels Panned
1	16	16	8	8
2	8	8	4	4
4	4	4	2	2
8	2	2	1	1

Examples

For the following examples we base our calculations on a 4 bit-per-pixel image displayed on a 256w × 64h panel. We have set up a virtual size of 320w × 240h. Width is greater than height so we are in landscape display mode. Refer to Section 2, “*Initialization*” on page 2-2 and Section 5.1, “*Virtual Display*” on page 2-15 for assistance with these settings.

These examples are shown using a C-like syntax.

Example 3 **Panning (Right and Left)**

To pan to the right increase the start address value by one. To pan to the left decrease the start address value. Keep in mind that, with the exception of 8 bit-per-pixel portrait display mode, the display will jump by more than one pixel as a result of changing the start address registers.

Panning to the right.

```
StartWord = GetStartAddress();
StartWord ++;
SetStartAddress(StartWord);
```

Panning to the left.

```
StartWord = GetStartAddress();
StartWord --;
if (StartWord < 0)
    StartWord = 0;
SetStartAddress(StartWord);
```

The routine `GetStartAddress()` is one which will read the start address registers and return the start address as a long value. It would be written similar to:

```
long GetStartAddress()
{
    return ((REG[10] & 1) * 65536) + (REG[0D] * 256) + (REG[0C]);
}
```

The routine `SetStartAddress()` break up its long integer argument into three register values and store the values.

```
void SetStartAddress(long SA)
{
    REG[0C] = SA        & 0xFF;
    REG[0D] = (SA >>  8) & 0xFF;
    REG[10] = (SA >> 16) & 0xFF;
}
```

Example 4

Scrolling (Up and Down)

To scroll down, increase the value in the Screen 1 Display Start Address Register by the number of words in one *virtual* scan line. To scroll up, decrease the value in the Screen 1 Display Start Address Register by the number of words in one *virtual* scan line. A virtual scan line includes both the number of bytes required by the physical display and any extra bytes that may be being used for creating a virtual width on the display.

The previous dimensions are still in effect for this example (i.e. 320w × 240h virtual size, 256h × 64w physical size at 4 bpp)

Step 1: Determine the number of words in one virtual scanline.

$$\text{bytes_per_line} = \text{pixels_per_line} / \text{pixels_per_byte} = 320 / 2 = 160$$

$$\text{words_per_line} = \text{bytes_per_line} / 2 = 160 / 2 = 80$$

Step 2: Scroll up or down

To scroll up.

```
StartWord = GetStartAddress();
StartWord -= words_per_line;
if (StartWord < 0)
StartWord = 0;
SetStartAddress(StartWord);
```

To scroll down.

```
StartWord = GetStartAddress();
StartWord += words_per_line;
SetStartAddress(StartWord);

}
```

5.3 Split Screen

Occasionally the need arises to display two different but related images. Take, for example, a game where the main play area requires rapid updates and game status, displayed at the bottom of the screen, requires infrequent updates.

The Split Screen feature of the S1D13705 allows a programmer to setup a display in such a manor. When correctly configured the programmer has only to update the main area on a regular basis. Occasionally, as the need arises, the secondary area is updated.

The figure below illustrates how a 320×240 panel may be configured to have one image displaying from scan line 0 to scan line 199 and image 2 displaying from scan line 200 to scan line 239. Although this example picks specific values, the split between image 1 and image 2 may occur at any line of the display.



Screen 1 Vertical Size Registers = 199 lines

Figure 5-2 320×240 Single Panel For Split Screen

In split screen operation “Image 1” is taken from the display memory location pointed to by the Screen 1 Start Address registers and is always located at the top of the screen. “Image 2” is taken from the display memory location pointed to by the Screen 2 Start Address registers. The line where “Image 1” end and “Image 2” begins is determined by the Screen 1 Vertical Size register.

Registers

Split screen operation is performed primarily by manipulating three register sets. Screen 1 Start Address and Screen 2 Start Address determine from where in display memory the first and second images will be taken from. The Vertical Size registers determine how many lines Screen 1 will use. The following is a description of the registers used to do split screen.

REG[13] Screen 1 Vertical Size (LSB)							
Bit 7	Bit 6	Bit 5	Bit 4	Bit 3	Bit 2	Bit 1	Bit 0
REG[14] Screen 1 Vertical Size (MSB)							
n/a	n/a	n/a	n/a	n/a	n/a	Bit 9	Bit 8

Screen 1 Vertical Size

These two registers form a ten bit value which determines the size of screen 1. When the vertical size is equal to or greater than the physical number of lines being displayed there is no visible effect on the display. When the vertical size value is less than the number of physical display lines, operation is like this:

1. From the beginning of a frame to the number of lines indicated by vertical size the display data will come from the memory area pointed to by the Screen 1 Display Start Address.
2. After *vertical size* lines have been displayed the system will begin displaying data from the memory area pointed to by Screen 2 Display Start Address.

One thing that must be pointed out here is that Screen 1 memory is **always** displayed at the top of the screen followed by screen 2 memory. This relationship holds true regardless of where in display memory Screen 1 Start Address and Screen 2 Start Address are pointing. For instance, Screen 2 Start Address may point to offset zero of display memory while Screen 1 Start Address points to a location several thousand bytes higher. Screen 1 will still be shown first on the display. While not particularly useful, it is even possible to set screen 1 and screen 2 to the same address.

REG[0Eh] Screen 2 Display Start Address 0 (LSB)							
Start Addr Bit 7	Start Addr Bit 6	Start Addr Bit 5	Start Addr Bit 4	Start Addr Bit 3	Start Addr Bit 2	Start Addr Bit 1	Start Addr Bit 0

REG[0Fh] Screen 2 Display Start Address 1 (MSB)							
Start Addr Bit 15	Start Addr Bit 14	Start Addr Bit 13	Start Addr Bit 12	Start Addr Bit 11	Start Addr Bit 10	Start Addr Bit 9	Start Addr Bit 8

Screen 2 Start Address Registers

These two registers form the sixteen bit Screen 2 Start Address. Screen 2 is always displayed immediately following the screen 1 data and will begin at the left-most pixel on a line. Keep in mind that if the Screen 1 Vertical Size is equal to or greater than the physical display then Screen 2 will not be shown.

In landscape mode these registers form the word offset to the first byte in display memory to be displayed. Changing these registers by one will shift the display image 2 to 16 pixels, depending on the current color depth.

The S1D13705 does not support split screen operation in portrait mode. Screen 2 will never be used if portrait mode is selected.

Refer to Table 5-1 to see the minimum number of pixels affected by a change of one to these registers

Screen 1 Start Address registers, REG[0C], REG[0D] and REG[10] are discussed in “Section” on page 2-17.

Examples

Example 5

Display 200 scanlines of image 1 and 40 scanlines of image 2. Image 2 is located first (offset 0) in the display buffer followed immediately by image 1. Assume a 320 × 240 display and a color depth of 4 bpp.

1. Calculate the Screen 1 Vertical Size register values.

$\text{vertical_size} = 200 = \text{C8h}$

Write the Vertical Size LSB, REG[13h], with C8h and Vertical Size MSB, REG[14h], with a 00h.

2. Calculate the Screen 1 Start Word Address register values.

Screen 2 is located first in display memory, therefore we must calculate the number of bytes taken up by the screen 2 data.

$\text{bytes_per_line} = \text{pixels_per_line} / \text{pixels_per_byte} = 320 / 2 = 160$

$\text{total bytes} = \text{bytes_per_line} \times \text{lines} = 160 \times 40 = 6400.$

Screen 2 requires 6400 bytes (0 to 6399) therefore the start address offset for screen 1 must be 6400 bytes. (6400 bytes = 3200 words = C80h words)

Set the Screen 1 Start Word Address MSB, REG[0Dh], to 0Ch and the Screen 1 Start Word Address LSB, REG[0Ch], to 80h.

3. Calculate the Screen 2 Start Word Address register values.

Screen 2 display data is coming from the very beginning of the display buffer. All there is to do here is ensure that both the LSB and MSB of the Screen 2 Start Word Address registers are set to zero.

6 LCD POWER SEQUENCING AND POWER SAVE MODES

6.1 LCD Power Sequencing

Correct power sequencing is required to prevent long term damage to LCD panels and to avoid unsightly "lines" during power-up and power-down. Power Sequencing allows the LCD power supply to discharge prior to shutting down the LCD logic signals.

Proper LCD power sequencing dictates there must be a time delay between the LCD power being disabled and the LCD signals being shut down. During power-up the LCD signals must be active prior to or when power is applied to the LCD. The time intervals vary depending on the power supply design.

The S1D13705 performs automatic power sequencing in response to both software power save (REG[03h]) or in response to a hardware power save. One frame after a power save mode is set, the S1D13705 disables LCD power, and the LCD logic signals continue for one hundred and twenty seven frames allowing the LCD power supply to completely discharge. For most applications the internal power sequencing is the appropriate choice.

There may be situations where the internal time delay is insufficient to discharge the LCD power supply before the LCD signals are shut down, or the delay is too long and the designer wishes to shorten it. This section details the sequences to manually power-up and power-down the LCD interface.

6.2 Registers

REG[03h] Mode Register 2							
				LCDPWR Override	Hardware Power Save Enable	Software Power Save bit 1	Software Power Save bit 0

The LCD Power (LCDPWR) Override bit forces LCD power inactive one frame after being toggled. As long as this bit is "1" LCD power will be disabled.

The Hardware Power Save Enable bit must be set in order to activate hardware power save through GPIO0.

The Software Power Save bits set and reset the software power save mode. These bits are set to "11" for normal operation and set to "00" for power save mode.

LCD logic signals to the display panel are active for 128 frames after setting either hardware or software power save modes. Power sequencing override is performed by setting the LCDPWR Override bit some time before setting a power save mode for power off sequences. During power on sequences the power save mode is reset some time before the LCDPWR Override is reset resulting in the LCD logic signals being active before power is applied to the panel.

6.3 *LCD Enable/Disable*

The descriptions below cover manually powering the LCD panel up and down. Use the sequences described in this section if the power supply connected to the panel requires more than 127 frames to discharge on power-down, or if the panel requires starting the LCD logic well in advance of enabling LCD power. Currently there are no known circumstances where the LCD logic must be active well in advance of LCD power.

Note: If 127 frame period is too long, blank the display, then reprogram the Horizontal and Vertical sizes to produce a shorter frame period before using these methods.

Power On/Enable Sequence

The following is a sequence for manually powering-up an LCD panel if LCD power had to be applied later than LCD logic.

1. Set REG[03h] bit 3 (LCDPWR Override) to "1". This ensures that LCD power will be held disabled.
2. Enable LCD logic. This is done by either setting the GPIO0 pin low to disable hardware power save mode and/or by setting REG[03h] bits 1-0 to "11" to disable software power save.
3. Count "x" Vertical Non-Display Periods (OPTIONAL).
"x" corresponds to the length of time LCD logic must be enabled before LCD power-up, converted to the equivalent vertical non-display periods. For example, at 72 HZ counting 36 non-display periods results in a one half second delay.
4. Set REG[03h] bit 3 to "0" to enable LCD Power.

Power Off/Disable Sequence

The following is a sequence for manually powering-down an LCD panel. These steps would be used if the power supply discharge requirements are larger than the default 127 frames.

1. Set REG[03h] bit 3 (LCDPWR Override) to "1" which will disable LCD Power.
2. Count "x" Vertical Non-Display Periods.
"x" corresponds to the power supply discharge time converted to the equivalent vertical non-display periods. (see the previous example)
3. Disable the LCD logic by setting the software power save in REG[03h] or setting hardware power save via GPIO0. Keep in mind that after setting the power save mode there will be 127 frames before the LCD logic signals are disabled.

7 HARDWARE ROTATION

7.1 Introduction To Hardware Rotation

Many of today's applications use the LCD panel in a SwivelView orientation (typically LCD panels are landscape oriented). In this case it becomes necessary to "rotate" the displayed image. This rotation can be done by software at the expense of performance or, as with the S1D13705, it can be done by hardware with no performance penalty.

This discussion of display rotation is intended to augment the excellent description of the hardware functionality found in the Hardware Functional Specification.

The S1D13705 supports two SwivelView modes: Default SwivelView Mode and Alternate SwivelView Mode.

7.2 Default SwivelView Mode

Default SwivelView mode was designed to reduce power consumption for SwivelView mode use. The reduced power consumption comes with certain trade offs.

The most obvious difference between the two modes is that Default Portrait Mode requires the SwivelView width be a power of two, e.g. a 240-line panel, used in SwivelView mode, requires setting a virtual width of 256 pixels. Also default SwivelView mode is only capable of scrolling the display in two line increments.

The benefits to using default SwivelView mode lies in the ability to use a slower input clock and in reduced power consumption.

The following figure depicts the ways to envision memory layouts for the S1D13705 in default SwivelView mode. This example uses a 320×240 panel.

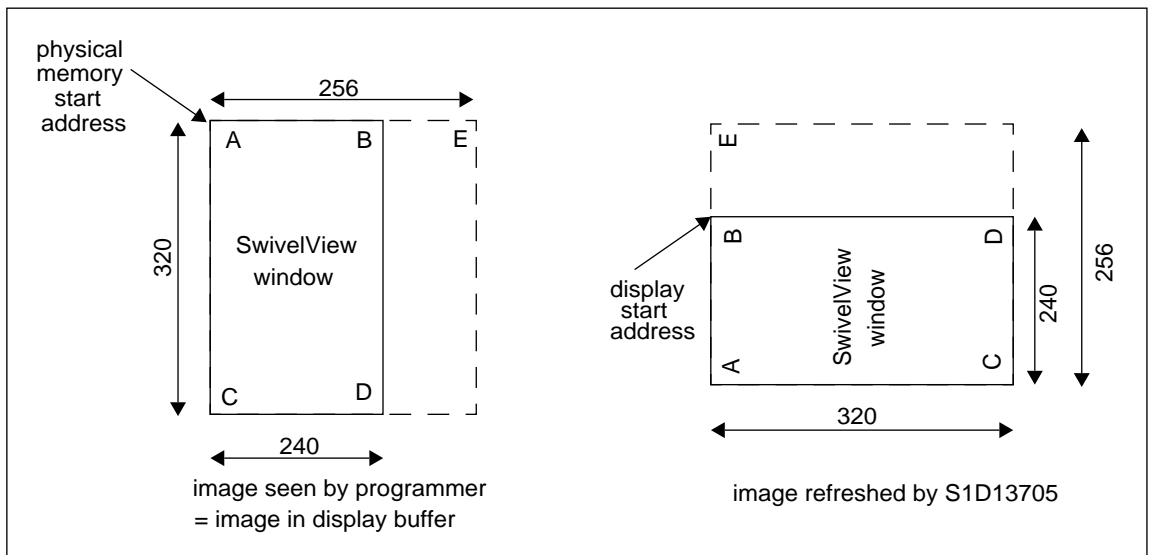

Figure 7-1 Relationship Between the Default Mode Screen Image and the Image Refreshed by S1D13705

From the programmer's perspective the memory is laid out as shown on the left. The programmer accesses memory exactly as for a panel of with the dimensions of 240×320 setup to have a 256 pixel horizontal stride. The programmer sees memory addresses increasing from A->B and from C->D.

From a hardware perspective the S1D13705 always refreshes the LCD panel in the order B->D and down to do A->C.

7.3 Alternate SwivelView Mode

Alternate SwivelView mode does not impose the power of two line width. To rotated the image on 240 line panel requires a portrait stride of 240 pixels. Alternate SwivelView mode is capable of scrolling by one line at a time in response to changes to the Start Address Registers. However, to achieve the same frame rate requires a 2 x faster input clock, therefore using more power.

The following figure depicts the ways to envision memory layouts for the S1D13705 in alternate SwivelView mode. This example also uses a 480 x 320 panel. Notice that in alternate SwivelView mode the stride may be as little as 240 pixels.

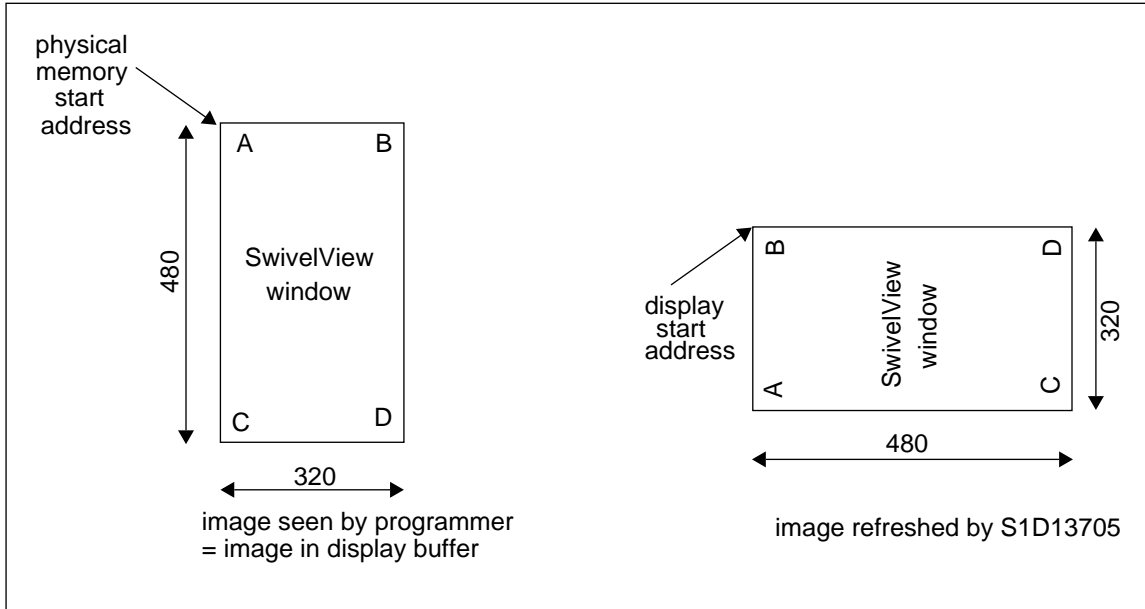

Figure 7-2 Relationship Between the Alternate Mode Screen Image and the Image Refreshed by S1D13705

From the programmers perspective the memory is laid out as shown on the left. The programmer accesses memory exactly as for a panel of with the dimensions of 480 x 320. The programmer sees memory addresses increasing from A->B and from C->D.

From a hardware perspective the S1D13705 always refreshes the LCD panel in the order B->D and down to do A->C

The greatest factor in selecting alternate SwivelView mode over default SwivelView mode would be for the ability to obtain an area of contiguous off screen memory. For example: A 640 x 480 panel in default SwivelView mode at two bit-per-pixel requires 81920 bytes (80 Kb). There is unused memory but it is not contiguous. The same situation using alternate SwivelView mode requires 76800 bytes leaving 5120 bytes of contiguous memory available to the application. In fact the change in memory usage may make the difference between being able to run certain panels in SwivelView mode or not being able to do so.

7.4 Registers

This section describes the registers used to set SwivelView mode operation.

REG[0Ch] Screen 1 Start Word Address LSB							
bit 7	bit 6	bit 5	bit 4	bit 3	bit 2	bit 1	bit 0

REG[0Dh] Screen 1 Start Word Address MSB							
bit 15	bit 14	bit 13	bit 12	bit 11	bit 10	bit 9	bit 8

REG[0Eh] Screen 1 Start Word Address MSB							
n/a	n/a	n/a	n/a	n/a	n/a	n/a	bit 16

The Screen 1 Start Address registers must be set correctly for SwivelView mode. In SwivelView mode the Start Address registers form a byte offset, as opposed to a word offset, into display memory.

The initial required offset is the SwivelView mode stride (in bytes) less one.

REG[1Ch] Line Byte Count Register							
bit 7	bit 6	bit 5	bit 4	bit 3	bit 2	bit 1	bit 0

The line byte count register informs the S1D13705 of the stride, in bytes, between two consecutive lines of display in SwivelView mode. The Line Byte Count register only affects SwivelView mode operation and are ignored when the S1D13705 is in landscape display mode.

REG[1Bh] SwivelView Mode Register							
SwivelView Mode Enable	SwivelView Mode Select	n/a	n/a	n/a	SwivelView Mode Memory Clock Select	SwivelView Mode Pixel Clock Select Bit 1	SwivelView Mode Pixel Clock Select Bit 0

The SwivelView mode register contains several items for SwivelView mode support.

The first is the SwivelView Mode Enable bit. When this bit is “0” the S1D13705 is in landscape mode and the remainder of the settings in this register as well as the Line Byte Count in REG[1Ch] are ignored. Set this bit to “1” to enable SwivelView mode.

The SwivelView mode select bit selects between the “Default Mode” and the “Alternate Mode”. Setting this bit to “0” selects the default SwivelView mode while setting this bit to “1” enables the alternate SwivelView mode.

SwivelView Mode Memory Clock Select is another power saving measure which can be enabled if the final MCLK value is less than or equal to 25 MHz. Memory Clock Select results in the S1D13705 temporarily increasing the memory clock circuitry on CPU access and resuming the slower speed when the access is complete. This results in better performance while using the least power.

In SwivelView display mode the CLKI (input clock) is routed to the SwivelView section of the S1D13705 as CLK. From the CLK signal the MCLK value can be determined from table 8-8 of the Hardware Functional Specification, document number X27A-A-001-xx. If MCLK is determined to be less than or equal to 25 MHz then SwivelView Mode Memory Clock Select may be enabled.

7.5 Limitations

The only limitation to using SwivelView mode on the S1D13705 is that split screen operation is not supported.

A comparison of the two SwivelView modes is as follows:

Table 7-1 Default and Alternate SwivelView Mode Comparison

Item	Default SwivelView Mode	Alternate SwivelView Mode
Memory Requirements	The width of the rotated image must be a power of 2. In most cases, a virtual image is required where the right-hand side of the virtual image is unused and memory is wasted. For example, a $320 \times 480 \times 4\text{bpp}$ image would normally require only 76,800 bytes - possible within the 80K byte address space, but the virtual image is $512 \times 480 \times 4\text{bpp}$ which needs 122,880 bytes - not possible.	Does not require a virtual image.
Clock Requirements	CLK need only be as fast as the required PCLK.	MCLK, and hence CLK, need to be 2X PCLK. For example, if the panel requires a 3MHz PCLK, then CLK must be 6MHz. Note that 25MHz is the maximum CLK, so PCLK cannot be higher than 12.5MHz in this mode.
Power Consumption	Lowest power consumption.	Higher than Default Mode.
Panning	Vertical panning in 2 line increments.	Vertical panning in 1 line increments.
Performance	Nominal performance. Note that performance can be increased by increasing CLK and setting $\text{MCLK} = \text{CLK} (\text{REG}[1\text{Bh}] \text{ bit } 2 = 1)$.	Higher performance than Default Mode. Note that performance can be increased by increasing CLK and setting $\text{MCLK} = \text{CLK} (\text{REG}[1\text{Bh}] \text{ bit } 2 = 1)$.

7.6 Examples

Example 6

Enable default SwivelView mode for a 320×240 panel at 4 bpp.

Before switching to SwivelView mode from landscape mode, display memory should be cleared to make the user perceived transition smoother. Images in display memory are not rotated automatically by hardware and a garbled image would be visible for a short period of time if video memory is not cleared.

If alternate SwivelView is used then the CLK signal is divided in half to get the PCLK signal. If the Input Clock Divide bit, in register[02] is set we can simply reset the divider. The result of this is a PCLK of exactly the same frequency as we used for landscape mode and we can use the current horizontal and vertical non-display periods. If the Input Clock Divide bit is not set then we must recalculate the frame rate based on the a PCLK value. In this example we will bypass recalculation of the horizontal and vertical non-display times (frame rate) by selecting the default SwivelView mode scheme.

1. Calculate and set the Screen 1 Start Word Address register.

$$\text{OffsetBytes} = (\text{Width} \times \text{BitsPerPixel} / 8) - 1 = (256 \times 4 / 8) - 1 = 127 = 007\text{Fh}$$

("Width" is the width of the SwivelView mode display - in this case the next power of two greater than 240 pixels or 256.)

Set Screen1 Display Start Word Address LSB (REG [0Ch]) to 7Fh and Screen1 Display Start Word Address MSB (REG[0Dh]) to 00h.

2. Calculate the Line Byte Count

The Line Byte Count also must be based on the power of two width.

$\text{LineByteCount} = \text{Width} \times \text{BitsPerPixel} / 8 = 256 \times 4 / 8 = 128 = 80\text{h}$.

Set the Line Byte Count (REG[1C]) to 80h.

3. Enable SwivelView mode.

This example uses the default SwivelView mode scheme. If we do not change the SwivelView Mode Pixel Clock Select bits then we will not have to recalculate the non-display timings to correct the frame rate.

Write 80h to the SwivelView Mode Register (REG[1Bh]).

The display is now configured for SwivelView mode use. Offset zero into display memory will correspond to the upper left corner of the display. The only item to keep in mind is that the count from the first pixel of one line to the first pixel of the next line (referred to as the “stride”) is 128 bytes.

Example 7

Enable alternate SwivelView mode for a 320x240 panel at 4 bpp.

Note: As we have to perform a frame rate calculation for this mode we need to know the following panel characteristics: 320 × 240 8-bit color to be run at 80 Hz with a 16 MHz input clock.

As in the previous example, before switching to SwivelView mode, display memory should be cleared. Images in display memory are not rotated automatically by hardware and the garbled image would be visible for a short period of time if video memory is not cleared.

1. Calculate and set the Screen 1 Start Word Address register.

$\text{OffsetBytes} = (\text{Width} \times \text{BitsPerPixel} / 8) - 1 = (240 \times 4 / 8) - 1 = 119 = 0077\text{h}$

Set Screen1 Display Start Word Address LSB (REG [0Ch]) to 77h and Screen1 Display Start Word Address MSB (REG[0Dh]) to 00h.

2. Calculate the Line Byte Count.

$\text{LineByteCount} = \text{Width} \times \text{BitsPerPixel} / 8 = 240 \times 4 / 8 = 120 = 78\text{h}$.

Set the Line Byte Count (REG[1C]) to 78h.

3. Enable SwivelView mode.

This example uses the alternate SwivelView mode scheme. We will not change the MCLK Autoswitch or Pixel Clock Select settings.

Write C0h to the SwivelView Mode register (REG[1Bh])

4. Recalculate the frame rate dependents.

This example assumes the alternate SwivelView mode scheme. In this scheme, without touching the Pixel Clock Select bits the PCLK value will be equal to CLK/2.

These examples don't use the Pixel Clock Select bits. The ability to divide the PCLK value down further than the default values was added to the S1D13705 to support hardware SwivelView mode on very small panels.

The Pixel Clock value has changed so we must calculate horizontal and vertical non-display times to reach the desired frame rate. Rather than perform the frame rate calculations here I will refer the reader to the frame rate calculations in “2.3 Frame Rate Calculation” on page 2-3 and simply “arrive” at the following:

Horizontal Non-Display Period = 88h

Vertical Non-Display Period = 03h

Plugging the values into the frame rate calculations yields:

$$\text{FrameRate} = \frac{\text{PCLK}}{(\text{HDP} + \text{HNDP}) \times (\text{VDP} + \text{VNDP})}$$

$$\text{FrameRate} = \frac{\frac{16,000,000}{2}}{(320 + 88) \times (240 + 3)} = 80.69$$

For this example the Horizontal Non-Display register [REG[08h]] needs to be set to 07h and the Vertical Non-Display register (REG[0Ah]) needs to be set to 03h.

The 16,000,000/2 in the formula above represents the input clock being divided by two when this alternate SwivelView mode is selected. With the values given for this example we must ensure the Input Clock Divide bit (REG[02h] b4) is reset (with the given values it was likely set as a result of the frame rate calculations for landscape display mode).

No other registers need to be altered.

The display is now configured for SwivelView mode use. Offset zero of display memory corresponds to the upper left corner of the display. Display memory is accessed exactly as it was for landscape mode.

As this is the alternate SwivelView mode the power of two stride issue encountered with the default SwivelView mode is no longer an issue. The stride is the same as the SwivelView mode width. In this case 120 bytes.

Example 8

Pan the above SwivelView mode image to the right by 4 pixels then scroll it up by 6 pixels.

To pan by four pixels the start address needs to be advanced.

1. Calculate the number of bytes to change start address by.

$$\text{Bytes} = \text{Pixels} \times \text{BitsPerPixel} / 8 = 4 \times 4 / 8 = 2 \text{ bytes}$$

2. Increment the start address registers by the just calculated value.

In this case the value write to the start address register will be 81h (7Fh + 2 = 81h)

To scroll by 4 lines we have to change the start address by the offset of four lines of display.

1. Calculate the number of bytes to change start address by.

$$\text{BytesPerLine} = \text{LineByteCount} = 128$$

$$\text{Bytes} = \text{Lines} \times \text{BytesPerLine} = 4 \times 128 = 512 = 200\text{h}$$

2. Increment the start address registers by the just calculated value

In this case 281h (81h + 200h) will be written to the Screen 1 Start Address register set.

Set Screen1 Display Start Word Address LSB (REG[0Ch]) to 81h and Screen1 Display Start Word Address MSB (REG[0Dh]) to 02h.

8 *IDENTIFYING THE S1D13705*

There are several similar products in the 1350x and 1370x LCD controller families. Products which can share significant portions of a generic code base. It may be important for a program to identify between products at run time.

Identification of the S1D13705 can be performed any time after the system has been powered up by reading REG[00h], the Revision Code register. The six most significant bits form the product identification code and the two least significant bits form the product revision.

From reset (power on) the steps to identifying the S1D13705 are as follows:

1. Read REG[00h]. Mask off the lower two bits, the revision code, to obtain the product code.
2. The product code for the S1D13705 is 024h.

9 *HARDWARE ABSTRACTION LAYER (HAL)*

9.1 *Introduction*

The HAL is a processor independent programming library provided by Epson. The HAL was developed to aid the implementation of internal test programs, and provides an easy, consistent method of programming the S1D13705 on different processor platforms. The HAL also allows for easier porting of programs between S1D1370x products. Integral to the HAL is an information structure (HAL_STRUCT) that contains configuration data on clocks, display modes, and default register values. This structure combined with the utility 1375CFG.EXE allows quick customization of a program for a new target display or environment.

Using the HAL keeps sample code simpler, although some programmers may find the HAL functions to be limited in their scope, and may wish to program the S1D13705 without using the HAL.

9.2 *Contents of the HAL_STRUCT*

The HAL_STRUCT below is contained in the file “hal.h” and is required to use the HAL library.

```
typedef struct tagHalStruct
{
    char    szIdString[16];
    WORD    wDetectEndian;
    WORD    wSize;
    BYTE    Regs [MAX_REG + 1];
    DWORD   dwClkI;           /* Input Clock Frequency (in kHz) */
    DWORD   dwDispMem;       /* Starting address of display buffer memory */
    WORD    wFrameRate;      /* Desired panel frame rate */
} HAL_STRUCT;
```

Within the Regs array is a structure which defines all the registers described in the *S1D13705 Hardware Functional Specification*, document number X27A-A-001-xx. Using the 1375CFG.EXE utility you can adjust the content of the registers contained in HAL_STRUCT to allow for different LCD panel timing values and other default settings used by the HAL. In the simplest case, the program only calls a few basic HAL functions and the contents of the HAL_STRUCT are used to setup the S1D13705 for operation.

9.3 *Using the HAL library*

To utilize the HAL library, the programmer must include two “.h” files in their code. “Hal.h” contains the HAL library function prototypes and structure definitions, and “appcfg.h” contains the instance of the HAL_STRUCT that is defined in “Hal.h” and configured by 1375CFG.EXE. For a more thorough example of using the HAL see Section 10.1, “Sample code using the S1D13705 HAL API” on page 2-46.

Note: Many of the HAL library functions have pointers as parameters. The programmer should be aware that little validation of these pointers is performed, so it is up to the programmer to ensure that they adhere to the interface and use valid pointers. Programmers are recommended to use the highest warning levels of their compiler in order to verify the parameter types.

9.4 API for 13705HAL

This section is a description of the HAL library Application Programmers Interface (API). Updates and revisions to the HAL may include new functions not included in this documentation.

Table 9-1 HAL Functions

Function	Description
Initialization:	
seRegisterDevice	Registers the SID13705 parameters with the HAL, calls seInitHal if necessary. seRegisterDevice MUST be the first HAL function called by an application.
seSetInit	Programs the SID13705 for use with the default settings, calls seSetDisplayMode to do the work, clears display memory. Note: either seSetInit or seSetDisplayMode must be called AFTER calling seRegisterDevice
General HAL Support:	
seGetId	Interpret the revision code register to determine chip id
seGetHalVersion	Return version information on the HAL library
seGetLastUsableByte	Determine the offset of the last unreserved usable byte in the display buffer
seGetBytesPerScanline	Determine the number of bytes or memory consumed per scan line in current mode
seGetScreenSize	Determine the height and width of the display surface in pixels
seDelay	Use the frame rate timing to delay for required seconds (requires registers to be initialized)
seSetHighPerformance	Used in color modes less than 8-bpp to toggle the high performance bit on or off
Advanced HAL Functions:	
seSplitInit	Initialize split screen variables and setup start addresses
seSplitScreen	Set the size of either the top or bottom screen
seVirtInit	Initialize virtual screen mode setting x and y sizes
seVirtMove	pan/scroll the virtual screen surface(s)
Hardware Rotate:	
seSetHWRotate	Set the hardware rotation to either Portrait or Landscape
seSetPortraitMethod	Call before setting hardware portrait mode to set either Default or Alternate Portrait Mode
Register / Memory Access:	
seSetReg	Write a Byte value to the specified SID13705 register
seGetReg	Read a Byte value from the specified SID13705 register
seWriteDisplayBytes	Write one or more bytes to the display buffer at the specified offset
seWriteDisplayWords	Write one or more words to the display buffer at the specified offset
seWriteDisplayDwords	Write one or more dwords to the display buffer at the specified offset
seReadDisplayByte	Read a byte from the display buffer from the specified offset
seReadDisplayWord	Read a word from the display buffer from the specified offset
seReadDisplayDword	Read a dword from the display buffer from the specified offset
Color Manipulation:	
seSetLut	Write to the Look-Up Table (LUT) entries starting at index 0
seGetLut	Read from the LUT starting at index 0
seSetLutEntry	Write one LUT entry (red, green, blue) at the specified index
seGetLutEntry	Read one LUT entry (red, green, blue) from the specified index
seSetBitsPerPixel	Set the color depth
seGetBitsPerPixel	Determine the current color depth
Drawing:	
seSetPixel	Draw a pixel at (x,y) in the specified color
seGetPixel	Read pixel's color at (x,y)
seDrawLine	Draw a line from (x1,y1) to (x2,y2) in specified color
seDrawRect	Draw a rectangle from (x1,y1) to (x2,y2) in specified color
Power Save:	
seSetPowerSaveMode	Control SID13705 SW power save mode (enable/disable)

Initialization

The following section describes the HAL functions dealing with S1D13705 initialization. Typically a programmer has only to concern themselves with calls to `seRegisterDevice()` and `seSetInit()`.

int seRegisterDevice(const LPHAL_STRUC lpHalInfo)

Description: This function registers the S1D13705 device parameters with the HAL library. The device parameters include address range, register values, desired frame rate, etc., and are stored in the HAL_STRUCT structure pointed to by lpHalInfo. Additionally this routine allocates system memory as address space for accessing registers and the display buffer.

Parameters: lpHalInfo - pointer to HAL_STRUCT information structure

Return Value: ERR_OK - operation completed with no problems
ERR_UNKNOWN_DEVICE - the HAL was unable to find an S1D13705.

Note: seRegisterDevice() MUST be called before any other HAL functions.
No S1D13705 registers are changed by calling seRegisterDevice().

seSetInit()

Description: Configures the S1D13705 for operation. This function sets all the S1D13705 control registers to their default values.

Initialization of the S1D13705 is a two step process to accommodate those programs (e.g. 1375PLAY.EXE) which do not initialize the S1D13705 on start-up.

Parameters: None

Return Value: ERR_OK - operation completed with no problems

Note: After this call the Look-Up Table will be set to a default state appropriate to the display type.

Unlike S1D1350x HAL versions, this function does not call `sesetDisplayMode` as this function does not exist in the 13705 HAL.

General HAL Support

Functions in this group do not fit into any specific category of support. They provide a miscellaneous range of support for working with the S1D13705.

int seGetId(int * pId)

Description: Reads the S1D13705 revision code register to determine the chip product and revisions. The interpreted value is returned in pID.

Parameters: pId - pointer to an integer which will receive the controller ID.

S1D13705 values returned in pID are:

- ID_S1D13705_REV0
- ID_UNKNOWN

Other HAL libraries will return their respective controller IDs upon detection of their controller.

Return Value: ERR_OK - operation completed with no problems
 ERR_UNKNOWN_DEVICE - the HAL was unable to identify the display controller. Returned when pID returns ID_UNKNOWN.

void seGetHalVersion(const char ** pVersion, const char ** pStatus, const char **pStatusRevision)

Description: Retrieves the HAL library version. The return pointers are all to ASCII strings. A typical return would be: *pVersion == "1.01" (HAL version 1.01), *pStatus == "B" (The 'B' is the beta designator), *pStatusRevision == "5". The programmer need only create pointers of const char type to pass as parameters (see Example below).

Parameters: pVersion - Pointer to string to return the version in.
 - must point to an allocated string of size VER_SIZE
 pStatus - Pointer to a string to return the release status in.
 - must point to an allocated string of size STATUS_SIZE
 pStatusRevision - Pointer to return the current revision of status.
 - must point to an allocated string of size STAT_REV_SIZE

Return Value: None

Example: const char *pVersion, *pStatus, *pStatusRevision;
 seGetHalVersion(&pVersion, &pStatus, &pStatusRevision);

int seSetBitsPerPixel(int BitsPerPixel)

Description: This routine sets the display color depth.

After performing validity checks to ensure the requested video mode can be set the appropriate registers are changed and the Look-Up Table is set its default values appropriate to the color depth.

This call is similar to a mode set call on a standard VGA.

Parameter: BitsPerPixel - desired color depth in bits per pixel.
- Valid arguments are: 1, 2, 4, and 8.

Return Value: ERR_OK - operation completed with no problems
ERR_FAILED - possible causes for this error include:

- 1) the desired frame rate may not be attainable with the specified input clock
- 2) the combination of width, height and color depth may require more memory than is available on the S1D13705.

int seGetBitsPerPixel(int * pBitsPerPixel)

Description: This function reads the S1D13705 registers to determine the current color depth and returns the result in *pBitsPerPixel*.

Parameters: pBitsPerPixel - pointer to an integer to receive current color depth.
- return values will be: 1, 2, 4, or 8.

Return Value: ERR_OK - operation completed with no problems

int seGetBytesPerScanline(int * pBytes)

Description: Determines the number of bytes per scan line of current display mode. It is assumed that the registers have already been correctly initialized before *seGetBytesPerScanline()* is called (i.e. after initializing the HAL, setting the Display mode and adjusting the bits per pixel or other values).

The number of bytes per scanline will include non-displayed bytes if the screen width is greater the display width, or in Default SwivelView Mode.

Parameters: pBytes - pointer to an integer to receive the number of bytes per scan line

Return Value: ERR_OK - operation completed with no problems

int seGetScreenSize(int * Width, int * Height)

Description: Retrieves the width and height in pixels of the display surface. The width and height are derived by reading the horizontal and vertical size registers and calculating the dimensions. Virtual dimensions are not taken into account for this calculation.

When the display is in SwivelView mode the dimensions will be swapped. (i.e. a 640x480 display in SwivelView mode will return a width of 480 and height of 640).

Parameters: Width - pointer to an integer to receive the display width
Height - pointer to an integer to receive the display height

Return value: ERR_OK - the operation completed successfully

int seDelay(int MilliSeconds)

Description: This function will delay for the length of time specified in “MilliSeconds” before returning to the caller.

This function was originally intended for non-PC platforms. Information about how to access the timers was not always available however we do know frame rate and can use that for timing calculations.

The S1D13705 registers must be initialized for this function to work correctly. On the PC platform this is simply a call to the C timing functions and is therefore independent of the register settings.

Parameters: MilliSeconds - time to delay in seconds

Return Value: ERR_OK - operation completed with no problems
ERR_FAILED - returned on non-PC platforms when the S1D13705 registers have not been initialized

int seGetLastUsableByte(long * pLastByte)

Description: This function returns a pointer, as a long integer, to the last byte of usable display memory.

The returned value never changes for the S1D13705.

Parameters: pLastByte - pointer to a long integer to receive the offset to the last byte of display memory

Return Value: ERR_OK - operation completed with no problems

int seSetHighPerformance(BOOL OnOff)

Description: This function call enables or disables the high performance bit of the S1D13705.

When high performance is enabled then MClk equals PClk for all video display resolutions. In the high performance state CPU to video memory performance is improved at the cost of higher power consumption.

When high performance is disabled then MClk ranges from PClk/1 at 8 bit-per-pixel to PClk/8 at 1 bit-per-pixel. Without high performance CPU to video memory speeds are slower and the S1D13705 uses less power.

Parameters: OnOff - a boolean value (defined in HAL.H) to indicate whether to enable or disable high performance.

Return Value: ERR_OK - operation completed with no problems

Advanced HAL Functions

Advanced HAL functions include the functions to support split, virtual and rotated displays. While the concept for using these features is advanced the HAL makes actually using them easy.

int seSetSwivelViewMethod(int Style)

Description: This selects the SwivelView mode method to be used when seSetHWRotate() is called to put the S1D13705 into SwivelView mode.

Parameters: Style - call with style set to DEFAULT (-1) to select Default SwivelView Mode
- call with style set to any other value to select Alternate SwivelView Mode.

Return Value: ERR_OK - operation completed with no problems
ERR_FAILED - the operation failed.

int seSetHWRotate(int Rotate)

Description: This function sets the rotation scheme according to the value of 'Rotate'. When portrait mode is selected as the display rotation the scheme selected is the 'non-X2' scheme.

Parameters: Rotate - the direction to rotate the display
- Valid arguments for Rotate are: LANDSCAPE and SwivelView.

Return Value: ERR_OK - operation completed with no problems
ERR_FAILED - the operation failed to complete.
The most likely reason for failing to set a rotate mode is an inability to set the desired frame rate when setting portrait mode. Other factors which can cause a failure include having a 0 Hz frame rate or specifying a value other than LANDSCAPE or SwivelView for the rotation scheme.

int seSplitInit(WORD Scrn1Addr, WORD Scrn2Addr)

Description: This function prepares the system for split screen operation. In order for split screen to function the starting address in the display buffer for the upper portion(screen 1) and the lower portion (screen 2) must be specified. Screen 1 is always displayed above screen 2 on the display regardless of the location of their start addresses.

Parameters: Scrn1Addr - offset, in bytes, to the start of screen 1
Scrn2Addr - offset, in bytes, to the start of screen 2

Return Value: ERR_OK - operation completed with no problems

Note: It is assumed that the system has been initialized prior to calling seSplitInit().

int seSplitScreen(int Screen, int VisibleScanlines)

Description: Changes the relevant registers to adjust the split screen according to the number of visible lines requested. 'WhichScreen' determines which screen, 1 or 2, to base the changes on.

The smallest surface screen 1 can display is one line. This is due to the way the S1D13705 operates. Setting Screen 1 Vertical Size to zero results in one line of screen 1 being displayed. The remainder of the display will be screen 2 image.

Parameters: Screen - must be set to 1 or 2 (or use the constants SCREEN1 or SCREEN2)
VisibleScanlines- number of lines to display for the selected screen

Return Value: ERR_OK - operation completed with no problems
ERR_HAL_BAD_ARG - argument VisibleScanlines is negative or is greater than vertical panel size or WhichScreen is not SCREEN 1 or SCREEN 2.

Note: Changing the number of lines for one screen will also change the number of lines for the other screen.

seSplitInit() must be called before calling seSplitScreen().

int seVirtInit(DWORD VirtX, DWORD * VirtY)

Description: This function prepares the system for virtual screen operation. The programmer passes the desired virtual width in pixels. When the routine returns *VirtY* will contain the maximum number of line that can be displayed at the requested virtual width.

Parameter: VirtX - horizontal size of virtual display in pixels.
(Must be greater or equal to physical size of display)
VirtY - pointer to an integer to receive the maximum number of displayable lines of 'VirtX' width.

Return Value: ERR_OK - operation completed with no problems
ERR_HAL_BAD_ARG - returned in three situations:
1) the virtual width (VirtX) is greater than the largest possible width
(VirtX varies with color depth and ranges from 4096 pixels wider than the panel at 1 bit-per-pixel down to 512 pixels wider than the panel at 8 bit-per-pixel)
2) the virtual width is less than the physical width or
3) the maximum number of lines becomes less than the physical number of lines

Note: The system must have been initialized prior to calling seVirtInit()

int seVirtMove(int Screen, int x, int y)

Description: This routine pans and scrolls the display. In the case where split screen operation is being used, the Screen argument specifies which screen to move. The x and y parameters specify, in pixels, the starting location in the virtual image for the top left corner of the applicable display.

Parameter: Screen - must be set to 1 or 2, or use the constants SCREEN1 or SCREEN2, to identify which screen to base calculations on
x - new starting X position in pixels
y - new starting Y position in pixels

Return Value: ERR_OK - operation completed with no problems
ERR_HAL_BAD_ARG - there are several reasons for this return value:
1) WhichScreen is not SCREEN1 or SCREEN2.
2) the y argument is greater than the last available line less the screen height.

Note: seVirtInit() must be been called before calling seVirtMove().

Register / Memory Access

The Register/Memory Access functions provide access to the S1D13705 registers and display buffer through the HAL.

int seGetReg(int Index, BYTE * pValue)

Description: Reads the value in the register specified by index.

Parameters: Index - register index to read
pValue - pointer to a BYTE to receive the register value.

Return Value: ERR_OK - operation completed with no problems

int seSetReg(int Index, BYTE Value)

Description: Writes value specified in Value to the register specified by Index.

Parameters: Index - register index to set
Value - value to write to the register

Return Value: ERR_OK - operation completed with no problems

int seReadDisplayByte(DWORD Offset, BYTE *pByte)

Description: Reads a byte from the display buffer at the specified offset and returns the value in pByte.

Parameters: Offset - offset, in bytes from start
of the display buffer, to read from
pByte - pointer to a BYTE to return the value in

Return Value: ERR_OK - operation completed with no problems
ERR_HAL_BAD_ARG - if the value for Addr is greater 80 kb

int seReadDisplayWord(DWORD Offset, WORD *pWord)

Description: Reads a word from the display buffer at the specified offset and returns the value in pWord.

Parameters: Offset - offset, in bytes from start of the display buffer, to read
from
pWord - pointer to a WORD to return the value in

Return Value: ERR_OK - operation completed with no problems.
ERR_HAL_BAD_ARG - if the value for Addr is greater than 80 kb.

int seReadDisplayDword(DWORD Offset, DWORD *pDword)

Description: Reads a dword from the display buffer at the specified offset and returns the value in pDword.

Parameters: Offset - offset from start of the display buffer to read from
pDword - pointer to a DWORD to return the value in

Return Value: ERR_OK - operation completed with no problems.
ERR_HAL_BAD_ARG - if the value for Addr is greater than 80 kb.

int seWriteDisplayBytes(DWORD Offset, BYTE Value, DWORD Count)

Description: This routine writes one or more bytes to the display buffer at the offset specified by Offset. If a count greater than one is specified all bytes will have the same value.

Parameters: Offset - offset from start of the display buffer to start writing at
 Value - BYTE value to write
 Count - number of bytes to write

Return Value: ERR_OK - operation completed with no problems
 ERR_HAL_BAD_ARG - if the value for Addr or the value of Addr plus Count is greater than 80 kb.

Note: There are slight functionality differences between the S1D1370x and the S1D1350x HAL.

int seWriteDisplayWords(DWORD Offset, WORD Value, DWORD Count)

Description: Writes one or more WORDS to the display buffer at the offset specified by Addr. If a count greater than one is specified all WORDS will have the same value.

Parameters: Offset - offset from start of the display buffer
 Value - WORD value to write
 Count - number of words to write

Return Value: ERR_OK - operation completed with no problems
 ERR_HAL_BAD_ARG - if the value for Addr or if Addr plus Count is greater than 80 kb.

Note: There are slight functionality differences between the S1D1370x and the S1D1350x HAL.

int seWriteDisplayDwords(DWORD Offset, DWORD Value, DWORD Count)

Description: Writes one or more DWORDS to the display buffer at the offset specified by Addr. If a count greater than one is specified all DWORDSs will have the same value.

Parameters: Offset - offset from start of the display buffer
 Value - DWORD value to write
 Count - number of dwords to write

Return Value: ERR_OK - operation completed with no problems
 ERR_HAL_BAD_ARG - if the value for Addr or if Addr plus Count is greater than 80 kb.

Note: There are slight functionality differences between the S1D1370x and the S1D1350x HAL.

Power Save

This section covers the HAL functions dealing with the Power Save features of the S1D13705.

int seSetPowerSaveMode(int PwrSaveMode)

Description: This function sets on the S1D13705's software selectable power save modes.

Parameters: PwrSaveMode - integer value specifying the desired power save mode.

Acceptable values for PwrSaveMode are:

0 - (software power save mode) in this mode registers and memory are read/writable. LCD output is forced low.

3 - (normal operation) all outputs function normally.

Return Value: ERR_OK- operation completed with no problems

Drawing

The Drawing routines cover HAL functions that deal with displaying pixels, lines and shapes.

int seSetPixel(long x, long y, DWORD Color)

Description: Draws a pixel at coordinates (x,y) in the requested color. This routine can be used for any color depth.

Parameters: x - horizontal coordinate of the pixel (starting from 0)
y - vertical coordinate of the pixel (starting from 0)
Color - at 1, 2, 4, and 8 bpp Color is an index into the LUT.
At 15 and 16 bpp Color defines the color directly
(i.e. rrrrrgggggbbbb for 16 bpp)

Return Value: ERR_OK - operation completed with no problems.

int seGetPixel(long x, long y, DWORD *pColor)

Description: Reads the pixel color at coordinates (x,y). This routine can be used for any color depth.

Parameters: x - horizontal coordinate of the pixel (starting from 0)
y - vertical coordinate of the pixel (starting from 0)
pColor - at 1, 2, 4, and 8 bpp pColor points to an index into the LUT.
At 15 and 16 bpp pColor points to the color directly
(i.e. rrrrrgggggbbbb for 16 bpp)

Return Value: ERR_OK - operation completed with no problems.

int seDrawLine(int x1, int y1, int x2, int y2, DWORD Color)

Description: This routine draws a line on the display from the endpoints defined by x1,y1 to the endpoint x2,y2 in the requested 'Color'.

Currently seDrawLine() only draws horizontal and vertical lines.

Parameters: (x1, y1)- first endpoint of the line in pixels
(x2, y2) - second endpoint of the line in pixels (see note below)
Color - color to draw with. 'Color' is an index into the LUT.

Return Value: ERR_OK - operation completed with no problems

Note: Functionality differs from the 1350x HAL.

int seDrawRect(long x1, long y1, long x2, long y2, DWORD Color, BOOL SolidFill)

Description: This routine draws and optionally fills a rectangular area of display buffer. The upper right corner is defined by x1,y1 and the lower right corner is defined by x2,y2. The color, defined by *Color*, applies both to the border and to the optional fill.

Parameters: x1, y1 - top left corner of the rectangle (in pixels)
x2, y2 - bottom right corner of the rectangle (in pixels)
Color - The color to draw the rectangle outline and fill with
- Color is an index into the Look-Up Table.
SolidFill - Flag whether to fill the rectangle or simply draw the border.
- Set to 0 for no fill, set to non-0 to fill the inside of the rectangle

Return Value: ERR_OK - operation completed with no problems.

LUT Manipulation

These functions deal with altering the color values in the Look-Up Table.

int seSetLut(BYTE *pLut, int Count)

Description: This routine writes one or more LUT entries. The writes always start with Look-Up Table index 0 and continue for 'Count' entries.

A Look-Up Table entry consists of three bytes, one each for Red, Green, and Blue. The color information is stored in the four most significant bits of each byte.

Parameters: pLut - pointer to an array of BYTE lut[16][3]
 lut[x][0] == RED component
 lut[x][1] == GREEN component
 lut[x][2] == BLUE component
 Count - the number of LUT entries to write.

Return Value: ERR_OK - operation completed with no problems

int seGetLut(BYTE *pLUT, int Count)

Description: This routine reads one or more LUT entries and puts the result in the byte array pointed to by pLUT.

A Look-Up Table entry consists of three bytes, one each for Red, Green, and Blue. The color information is stored in the four most significant bits of each byte.

Parameters: pLUT - pointer to an array of BYTE lut[16][3]
 - pLUT must point to enough memory to hold 'Count' x 3 bytes of data.
 Count - the number of LUT elements to read.

Return Value: ERR_OK - operation completed with no problems

int seSetLutEntry(int Index, BYTE *pEntry)

Description: This routine writes one LUT entry. Unlike seSetLut, the LUT entry indicated by 'Index' can be any value from 0 to 255.

A Look-Up Table entry consists of three bytes, one each for Red, Green, and Blue. The color information is stored in the four most significant bits of each byte.

Parameters: Index - index to LUT entry (0 to 255)
 pLUT - pointer to an array of three bytes.

Return Value: ERR_OK - operation completed with no problems

int seGetLutEntry(int index, BYTE *pEntry)

Description: This routine reads one LUT entry from any index.

A Look-Up Table entry consists of three bytes, one each for Red, Green, and Blue. The color information is stored in the four most significant bits of each byte.

Parameters: Index - index to LUT entry (0 to 255)
 pEntry - pointer to an array of three bytes

Return Value: ERR_OK - operation completed with no problems

9.5 Porting LIBSE to a new target platform

Building Epson Research and Development applications like a simple HelloApp for a new target platform requires 3 things, the HelloApp code, the 13705 HAL library, and a some standard C functions (portable ones are encapsulated in our mini C library LIBSE).



Components needed to build 13705 HAL application

For example, when building HELLOAPP.EXE for the Intel 16-bit platform, you need the HELLOAPP source files, the 13705 HAL library and its include files, and some Standard C library functions (which in this case would be supplied by the compiler as part of its run-time library). As this is a DOS .EXE application, you do not need to supply start-up code that sets up the chip selects or interrupts, etc... What if you wanted to build the application for an SH-3 target, one not running DOS?

Before you can build that application to load onto the target, you need to build a C library for the target that contains enough of the Standard C functions (like `sprintf` and `strcpy`) to let you build the application. Epson Research and Development supplies the LIBSE for this purpose, but your compiler may come with one included. You also need to build the 13705 HAL library for the target. This library is the graphics chip dependent portion of the code. Finally, you need to build the final application, linked together with the libraries described earlier. The following examples assume that you have a copy of the complete source code for the S1D13705 utilities, including the `nmake` makefiles, as well as a copy of the GNU Compiler v2.7-96q3a for Hitachi SH3. These are available on the World Wide Web at <http://www.eea.epson.com>.

Building the LIBSE library for SH3 target example

In the LIBSE files, there are three main types of files:

- C files that contain the library functions.
- assembler files that contain the target specific code.
- makefiles that describe the build process to construct the library.

The C files are generic to all platforms, although there are some customizations for targets in the form of `#ifdef LCEVBSH3` code (the `ifdef` used for the example SH3 target Low Cost Eval Board SH3). The majority of this code remains constant whichever target you build for.

The assembler files contain some platform setup code (stacks, chip selects) and jumps into the main entry point of the C code that is contained in the C file `entry.c`. For our example, the assembler file is `STARTSH3.S` and it performs only some stack setup and a jump into the code at `_mainEntry` (`entry.c`).

In the embedded targets, `printf` (in file `rprintf.c`), `putchar` (`putchar.c`) and `getch` (`kb.c`) resolve to serial character input/output. For SH3, much of the detail of handling serial IO is hidden in the monitor of the evaluation board, but in general the primitives are fairly straight forward, providing the ability to get characters to/from the serial port.

For our target example, the `nmake` makefile is `makesh3.mk`. This makefile calls the Gnu compiler at a specific location (`TOOLDIR`), enumerates the list of files that go into the target and builds a `.a` library file as the output of the build process.

With `nmake.exe` in your path run:

```
nmake -fmakesh3.mk
```

Building the HAL library for the target example

Building the HAL for the target example is less complex because the code is written in C and requires little platform specific adjustment. The nmake makefile for our example is makesh3.mk. This makefile contains the rules for building sh3 objects, the files list for the library and the library creation rules. The Gnu compiler tools are pointed to by TOOLDIR.

With nmake in your path run:

nmake -fmakesh3.mk



10 SAMPLE CODE

Included in the sample code section are two examples of programming the S1D13705. The first sample uses the HAL to draw a red square, wait for user input then rotates to portrait mode and draws a blue square. The second sample code performs the same procedures but directly accesses the registers of the S1D13705. These code samples are for example purposes only.

10.1 Sample code using the S1D13705 HAL API

```

/*
**=====
** SAMPLE1.C - Sample code demonstrating a program using the S1D13705 HAL.
**-----
** Created 1998, Vancouver Design Centre
** Copyright (c) 1998, 1999 Epson Research and Development, Inc.
** All Rights Reserved.
**-----
**
** The HAL API code is configured for the following:
**
** 320x240 Single Color 4-bit STN
** 8 bpp - 70 Hz Frame Rate (6 MHz CLKi)
** High Performance enabled
**
**=====
*/
#include <conio.h>
#include <stdio.h>
#include <stdlib.h>
#include <string.h>
#include "hal.h"           /* Structures, constants and prototypes. */
#include "appcfg.h"       /* HAL configuration information. */
/*-----*/
void main(void)
{
    int    ChipId;
    /*
    ** Initialize the HAL.
    ** The call to seRegisterDevice() actually prepares the HAL library
    ** for use. The S1D13705 is not accessed, except to read the revision
    ** code register.
    */
    if (ERR_OK != seRegisterDevice(&HalInfo))
    {
        printf("\nERROR: Could not register S1D13705 device.");
        exit(1);
    }
    /*
    ** Get the product code to verify this is an S1D13705.
    */
    seGetId(&ChipId);
    if (ID_S1D13705_Rev1 != ChipId)
    {
        printf("\nERROR: Did not detect an S1D13705.");
        exit(1);
    }
    /*
    ** Initialize the S1D13705.
    ** This step programs the registers with values taken from
    ** the HalInfo struct in appcfg.h.
    */
    if (ERR_OK != seSetInit())

```

```
{
    printf("\nERROR: Could not initialize device.");
    exit(1);
}
/*
** The default initialization cleared the display.
** Draw a 100x100 red (color 1) rectangle in the upper
** left corner (0,0) of the display.
*/
seDrawRect(0, 0, 100, 100, 1, TRUE);
/*
** Pause here.
*/
getch();
/*
** Clear the display. Do this by writing 81920 bytes
*/
seWriteDisplayBytes(0, 0, EIGHTY_K);
/*
** Setup portrait mode.
*/
seSetHWrotate(PORTAIT);
/*
** Draw a solid blue 100x100 rectangle in center of the display.
** This starting co-ordinates, assuming a 320x240 display is
** (320-100)/2 , (240-100)/2 = 110,70.
*/
seDrawRect(110, 70, 210, 170, 2, TRUE);
/*
** Done!
*/
exit(0);
}
```

10.2 Sample code without using the S1D13705 HAL API

This second sample demonstrates exactly the same sequence as the first however the HAL is not used, all manipulation is done by directly accessing the registers.

```

/*
*****
** SAMPLE2.C - Sample code demonstrating a direct access of the S1D13705.
**-----
** Created 1998, Vancouver Design Centre
** Copyright (c) 1998, 1999 Epson Research and Development, Inc.
** All Rights Reserved.
**-----
**
** The sample code using direct S1D13705 access
** will configure for the following:
**
** 320x240 Single Color 4-bit STN
** 8 bpp color depth - 70 Hz Frame Rate (6 MHz CLKi)
**
** Notes:
** 1) This code is written to be compiled for use under 32-bit
**    Windows. In order to function the vxd file S1D13XXX.VXD must
**    be in the \WINDOWS\SYSTEM directory.
** 2) Register setup is done with discreet writes rather than being table
**    driven. This allows for clear commenting. It is more efficient to
**    loop through the array writing each element to a control register.
** 3) The array of register values as produced by 1375CFG.EXE is included
**    here. I write the registers directly rather than refer to the register
**    array in the sample code.
**
*****
*/
#include <conio.h>
#include <windows.h>
#include <winioctl.h>
#include "ioctl.h"
/*
** Look-Up Table - 16 of 256 elements.
** For this sample only the first sixteen LUT elements are set.
*/
unsigned char LUT[16*3] =
{
    0x00, 0x00, 0x00, /* BLACK */
    0x00, 0x00, 0xA0, /* BLUE */
    0x00, 0xA0, 0x00, /* GREEN */
    0x00, 0xA0, 0xA0, /* CYAN */
    0xA0, 0x00, 0x00, /* RED */
    0xA0, 0x00, 0xA0, /* PURPLE */
    0xA0, 0xA0, 0x00, /* YELLOW */
    0xA0, 0xA0, 0xA0, /* WHITE */
    0x00, 0x00, 0x00, /* BLACK */
    0x00, 0x00, 0xF0, /* LT BLUE */
    0x00, 0xF0, 0x00, /* LT GREEN */
    0x00, 0xF0, 0xF0, /* LT CYAN */
    0xF0, 0x00, 0x00, /* LT RED */
    0xF0, 0x00, 0xF0, /* LT PURPLE */
    0xF0, 0xF0, 0x00, /* LT YELLOW */
    0xF0, 0xF0, 0xF0, /* LT WHITE */
};
/*
** Register data.
** These values were generated using 1375CFG.EXE.
** The sample code uses these values but does not refer to this array.
** In a typical application these values would be written to the registers

```

```

** using a loop.
*/
unsigned char Reg[0x20] =
{
    0x00, 0x23, 0xC0, 0x03, 0x27, 0xEF, 0x00, 0x00,
    0x00, 0x00, 0x03, 0x00, 0x00, 0x00, 0x00, 0x00,
    0x00, 0x00, 0xFF, 0x03, 0x00, 0x00, 0x00, 0x00,
    0x00, 0x00, 0x00, 0x00, 0x00
};
#define MEM_SIZE 0x14000/* 80 kb display buffer.          */
typedef unsigned short WORD; /* Some useful types */
typedef unsigned long DWORD;
typedef unsigned char BYTE;
typedef BYTE      * PBYTE;
#define LOBYTE(w)      ((BYTE)(w))
#define HIBYTE(w)      ((BYTE)(((WORD)(w) >> 8) & 0xFF))
#define SET_REG(idx, val) (*(pRegs + idx)) = (val)
/*-----*/
void main(void)
{
    PBYTE p13705;
    PBYTE pRegs;
    PBYTE pMem;
    PBYTE pLUT;
    int x, y, tmp;
    int BitsPerPixel = 8;
    int Width        = 320;
    int Height       = 240;
    int OffsetBytes;
    int rc;
    /*
    ** Get a linear address we can use in our code to access the S1D13705.
    ** This is only needed to access the S1D13705 on the ISA eval board.
    */
    DWORD dwLinearAddress;
    rc = IntelGetLinAddressW32(0xF00000, &dwLinearAddress);
    if (rc != 0)
    {
        printf("Error getting linear address");
        return;
    }
    p13705 = (PBYTE)dwLinearAddress;
    pRegs = p13705 + 0x1FFE0;
    /*
    ** Check the revision code. Exit if we don't find an S1D13705.
    */
    if (0x24 != *pRegs)
    {
        printf("Didn't find an S1D13705");
        return;
    }
    /*
    ** Initialize the chip - after initialization the display will be
    ** setup for landscape use.
    ** Normally a loop would be used to write the register array near
    ** the top of this file to the registers.
    ** For purposes of documenting the sample code, each register write
    ** is performed individually.
    */
    /*
    ** Register 01h: Mode Register 0 - Color, 8-bit format 2
    */
    SET_REG(0x01, 0x20);
    /*

```

```

** Register 02h: Mode Register 1 - 8BPP
*/
SET_REG(0x02, 0xC0);
/*
** Register 03h: Mode Register 2 - Normal power mode
*/
SET_REG(0x03, 0x03);
/*
** Register 04h: Horizontal Panel Size - 320 pixels - (320/8)-1 = 39 = 27h
*/
SET_REG(0x04, 0x27);
/*
** Register 05h: Vertical Panel Size LSB - 240 pixels
** Register 06h: Vertical Panel Size MSB - (240 - 1) = 239 = EFh
*/
SET_REG(0x05, 0xEF);
SET_REG(0x06, 0x00);
/*
** Register 07h - FPLINE Start Position - not used by STN
*/
SET_REG(0x07, 0x00);
/*
** Register 08h - Horizontal Non-Display Period = (Reg[08] + 4) * 8
**                                     = (0+4) * 8 = 32 pels
** - HNDP and VNDP are calculated to achieve the
**   desired frame rate according to:
**
**                                     PCLK
**   Frame Rate = -----
**                   (HDP + HNDP) * (VDP + VNDP)
*/
SET_REG(0x08, 0x00);
/*
** Register 09h - FPFRAME Start Position - not used by STN
*/
SET_REG(0x09, 0x00);
/*
** Register 0Ah - Vertical Non-Display Register = 3 lines
** - Calculated in conjunction with register 08h (HNDP) to
**   achieve the desired frame rate.
*/
SET_REG(0x0A, 0x03);
/*
** Register 0Bh - MOD Rate - not used by this panel
*/
SET_REG(0x0B, 0x00);
/*
** Register 0Ch - Screen 1 Start Word Address LSB
** Register 0Dh - Screen 1 Start Word Address MSB
** - Start address should be set to 0
*/
SET_REG(0x0C, 0x00);
SET_REG(0x0D, 0x00);
/*
** Register 0Eh - Screen 2 Start Word Address LSB
** Register 0Fh - Screen 2 Start Word Address MSB
** - Set this start address to 0 too
*/
SET_REG(0x0E, 0x00);
SET_REG(0x0F, 0x00);
SET_REG(0x10, 0x00); /* Screen1/Screen2 Start Address High bits. */
/*
** Register 11h - Memory Address Offset
** - Used for setting memory to a width greater than the

```

```

**          display size. Usually set to 0 during initialization
**          and programmed to desired value later.
*/
SET_REG(0x11, 0x00);
/*
** Register 12h - Screen 1 Vertical Size LSB
** Register 13h - Screen 1 Vertical Size MSB
**          - Set to maximum (i.e. 0x3FF). This register is used
**          for split screen operation. Normally it is set to
**          maximum value.
*/
SET_REG(0x12, 0xFF);
SET_REG(0x13, 0x03);
/*
** Look-Up Table registers
** The LUT is programmed at the end of the initialization sequence.
*/
/*
** Register 18h - GPIO Configuration - set to 0
**          - '0' configures the GPIO pins for input (power on default)
*/
SET_REG(0x18, 0x00);
/*
** Register 19h - GPIO Status - set to 0
**          - This step has no real purpose. It sets the GPIO
**          pins low should GPIO be set as outputs.
*/
SET_REG(0x19, 0x00);
/*
** Register 1Ah - Scratch Pad - set to 0
**          - Use this register to store whatever state data your
**          system may require.
*/
SET_REG(0x1A, 0x00);
/*
** Register 1Bh - Portrait Mode - set to 0 - disable portrait mode
*/
SET_REG(0x1B, 0x00);
/*
** Register 1Ch - Line Byte Count - set to 0 - used only by portrait mode.
*/
SET_REG(0x0C, 0x00);
/*
** Look-Up Table
** In this example we only set the first sixteen LUT entries.
** In typical use all 256 entries would be setup.
*/
/*
** Register 15h - Look-Up Table Address
**          - Set to 0 to start RGB sequencing at the first LUT entry.
*/
SET_REG(0x15, 0x00);
/*
** Register 17h - Look-Up Table Data
**          - Write 16 RGB triplets to the LUT.
*/
pLUT = LUT;
for (tmp = 0; tmp < 16; tmp++)
{
    SET_REG(0x17, *pLUT); // Set Red
    pLUT++;
    SET_REG(0x17, *pLUT); // Set Green
    pLUT++;
    SET_REG(0x17, *pLUT); // Set Blue
}

```



```

        pLUT++;
    }
    /*
    ** Clear all of video memory by writing 81920 bytes of 0.
    */
    pMem = p13705;
    for (tmp = 0; tmp < MEM_SIZE; tmp++)
    {
        *pMem = 0;
        pMem++;
    };
    /*
    ** Draw a 100x100 red rectangle in the upper left corner (0,0)
    ** of the display.
    */
    for (y = 0; y < 100; y++)
    {
        /*
        ** Set the memory pointer at the start of each line.
        ** Pointer = MEM_OFFSET + (Y * Line_Width * BPP / 8) + (X * BPP / 8)
        */
        pMem = p13705 + (y * 320 * BitsPerPixel / 8) + 0;
        for (x = 0; x < 100; x++)
        {
            *pMem = 0x4; /* Draw a pixel with LUT color 4 */
            pMem++;
        }
    }
    /*
    ** Wait for the user to press a key before continuing.
    */
    printf("Press any key to continue");
    getch();
    /*
    ** Set and use PORTRAIT mode.
    */
    /*
    ** Clear the display, and all of video memory, by writing 81920 bytes
    ** of 0. This is done because an image in display memory is not rotated
    ** when the switch to portrait display mode occurs.
    */
    pMem = p13705;
    for (tmp = 0; tmp < MEM_SIZE; tmp++)
    {
        *pMem = 0;
        pMem++;
    };
    /*
    ** We will use the default portrait mode scheme so we have to adjust
    ** the ROTATED width to be a power of 2.
    ** (NOTE: current height will become the rotated width)
    */
    tmp = 1;
    while (Height > (1 << tmp))
        tmp++;
    Height = (1 << tmp);
    OffsetBytes = Height * BitsPerPixel / 8;
    /*
    ** Set:
    ** 1) Line Byte Count to size of the ROTATED width (i.e. current height)
    ** 2) Start Address to the offset of the width of the ROTATED display.
    **    (in portrait mode the start address registers point to bytes)
    */
    SET_REG(0x1C, (BYTE)OffsetBytes);

```

```

OffsetBytes--;
SET_REG(0x0C, LOBYTE(OffsetBytes));
SET_REG(0x0D, HIBYTE(OffsetBytes));
/*
** Set Portrait mode.
** Use the non-X2 (default) scheme so we don't have to re-calc the frame
** rate. MCLK will be <= 25 MHz so we can leave auto-switch enabled.
*/
SET_REG(0x1B, 0x80);
/*
** Draw a solid blue 100x100 rectangle centered on the display.
** Starting co-ordinates, assuming a 320x240 display are:
**   (320-100)/2 , (240-100)/2 = 110,70.
*/
for (y = 70; y < 180; y++)
{
    /*
    ** Set the memory pointer at the start of each line.
    **   Pointer = MEM_OFFSET + (Y * Line_Width * BPP / 8) + (X * BPP / 8)
    **   NOTICE: as this is default portrait mode, the width is a power
    **             of two. In this case, we use a value of 256 pixels for
    **             our calculations instead of the panel dimension of 240.
    return -1;
Arr[0] = physaddr;
Arr[1] = 4 * 1024 * 1024;
rc = DeviceIoControl(hDriver, IOCTL_SED_MAP_PHYSICAL_MEMORY,
                    &Arr[0], 2 * sizeof(ULONG), &retVal, sizeof(ULONG),
                    &cbReturned, NULL);

if (rc)
    *linaddr = retVal;

/*
** Close the handle.
** This will dynamically UNLOAD the Virtual Device for Win95.
*/
CloseHandle(hDriver);
if (rc)
    return 0;
return -1;
}

```

10.3 Header Files

The header files included here are the required for the HAL sample to compile correctly.

```

/*
*****
** HAL.H - Header file for use with programs written to use the S1D13705 HAL.
**-----
** Created 1998, Vancouver Design Centre
** Copyright (c) 1998, 1999 Epson Research and Development, Inc.
** All Rights Reserved.
*****
*/
#ifndef _HAL_H_
#define _HAL_H_
#include "hal_regs.h"
/*-----*/
typedef unsigned char BYTE;
typedef unsigned short WORD;
typedef unsigned long DWORD;
typedef unsigned int UINT;
typedef int BOOL;
#ifdef INTEL
typedef BYTE far *LPBYTE;
typedef WORD far *LPWORD;
typedef UINT far *LPUINT;
typedef DWORD far *LPDWORD;
#else
typedef BYTE *LPBYTE;
typedef WORD *LPWORD;
typedef UINT *LPUINT;
typedef DWORD *LPDWORD;
#endif
#ifndef LOBYTE
#define LOBYTE(w) ((BYTE)(w))
#endif
#ifndef HIBYTE
#define HIBYTE(w) ((BYTE)(((UINT)(w) >> 8) & 0xFF))
#endif
#ifndef LOWORD
#define LOWORD(l) ((WORD)(DWORD)(l))
#endif
#ifndef HIWORD
#define HIWORD(l) ((WORD)((((DWORD)(l)) >> 16) & 0xFFFF))
#endif
#ifndef MAKEWORD
#define MAKEWORD(lo, hi) ((WORD)(((WORD)(lo)) | (((WORD)(hi)) << 8)))
#endif
#ifndef MAKELONG
#define MAKELONG(lo, hi) ((long)(((WORD)(lo)) | (((DWORD)((WORD)(hi))) << 16)))
#endif
#ifndef TRUE
#define TRUE 1
#endif
#ifndef FALSE
#define FALSE 0
#endif
#define OFF 0
#define ON 1
#define SCREEN1 1
#define SCREEN22
/*
** Constants for HW rotate support
*/
#define DEFAULT 0

```

```

#define LANDSCAPE 1
#define PORTRAIT2
#ifndef NULL
#ifdef __cplusplus
#define NULL 0
#else
#define NULL ((void *)0)
#endif
#endif
/*-----*/
/*
** SIZE_VERSION is the size of the version string (eg. "1.00")
** SIZE_STATUS is the size of the status string (eg. "b" for beta)
** SIZE_REVISION is the size of the status revision string (eg. "00")
*/
#define SIZE_VERSION 5
#define SIZE_STATUS 2
#define SIZE_REVISION 3
#ifdef ENABLE_DPF /* Debug_printf() */
#define DPF(exp) printf(#exp "\n")
#define DPF1(exp) printf(#exp " = %d\n", exp)
#define DPF2(exp1, exp2) printf(#exp1 "=%d " #exp2 "=%d\n", exp1, exp2)
#define DPFL(exp) printf(#exp " = %x\n", exp)
#else
#define DPF(exp) ((void)0)
#define DPF1(exp) ((void)0)
#define DPFL(exp) ((void)0)
#endif
/*-----*/
enum
{
ERR_OK = 0, /* No error, call was successful. */
ERR_FAILED, /* General purpose failure. */
ERR_UNKNOWN_DEVICE, /* */
ERR_INVALID_PARAMETER, /* Function was called with invalid parameter. */
ERR_HAL_BAD_ARG,
ERR_TOOMANY_DEVS
};
/*****
* Definitions for seGetId()
*****/
#define PRODUCT_ID 0x24
enum
{
ID_UNKNOWN,
ID_S1D13705_Rev1
};
#define MAX_MEM_ADDR81920 - 1
#define EIGHTY_K81920
#define MAX_DEVICE 10
#define SE_RSVD0
/*****
* Definitions for Internal calculations.
*****/
#define MIN_NON_DISP_X 32
#define MAX_NON_DISP_X 256
#define MIN_NON_DISP_Y 2
#define MAX_NON_DISP_Y 64
enum
{
RED,
GREEN,
BLUE
};

```

```

/*****
typedef struct tagHalStruct
{
    char    szIdString[16];
    WORD    wDetectEndian;
    WORD    wSize;
    BYTE    Reg[MAX_REG + 1];
    DWORD   dwClkI;/* Input Clock Frequency (in kHz) */
    DWORD   dwDispMem;/* */
    WORD    wFrameRate;/* */
} HAL_STRUCT;
typedef HAL_STRUCT * PHAL_STRUCT;
#ifdef INTEL_16BIT
typedef HAL_STRUCT far * LPHAL_STRUCT;
#else
typedef HAL_STRUCT    * LPHAL_STRUCT;
#endif
/*=====*/
/*                      FUNCTION  PROTO-TYPES                      */
/*=====*/
/*----- Initialization -----*/
int seRegisterDevice( const LPHAL_STRUCT lpHalInfo );
int seSetInit( void );
int seInitHal( void );
/*----- Miscellaneous -----*/
int  seGetId( int *pId );
void seGetHalVersion( const char **pVersion, const char **pStatus,
                    const char **pStatusRevision );
int seSetBitsPerPixel( int nBitsPerPixel );
int seGetBitsPerPixel( int *pBitsPerPixel );
int seGetBytesPerScanline( int *pBytes );
int seGetScreenSize( int *width, int *height );
void seDelay( int nMilliseconds );
int seGetLastUsableByte( long *LastByte );
int seSetHighPerformance( BOOL OnOff );
/*----- Advanced -----*/
int seSetHWRotate( int nMode );
int seSplitInit( WORD Scrn1Addr, WORD Scrn2Addr );
int seSplitScreen( int WhichScreen, int VisibleScanlines );
int seVirtInit( int xVirt, long *yVirt );
int seVirtMove( int nWhichScreen, int x, int y );
/*----- Register/Memory Access -----*/
int seGetReg( int index, BYTE *pValue );
int seSetReg( int index, BYTE value );
int seReadDisplayByte( DWORD offset, BYTE *pByte );
int seReadDisplayWord( DWORD offset, WORD *pWord );
int seReadDisplayDword( DWORD offset, DWORD *pDword );
int seWriteDisplayBytes( DWORD addr, BYTE val, DWORD count );
int seWriteDisplayWords( DWORD addr, WORD val, DWORD count );
int seWriteDisplayDwords( DWORD addr, DWORD val, DWORD count );
/*----- Power Save -----*/
int seHWSuspend( int nDevID, BOOL val );
int seSetPowerSaveMode( int nDevID, int PowerSaveMode );
/*----- Drawing -----*/
int seDrawLine( int x1, int y1, int x2, int y2, DWORD color );
int seDrawRect( int x1, int y1, int x2, int y2, DWORD color, BOOL Solidfill );
/*----- Color -----*/
int seSetLut( BYTE *pLut );
int seGetLut( BYTE *pLut );
int seSetLutEntry( int index, BYTE *pEntry );
int seGetLutEntry( int index, BYTE *pEntry );
#endif    /* _HAL_H */
/*
**=====

```

```

** APPCFG.H - Application configuration information.
**-----
** Created 1998 - Vancouver Design Centre
** Copyright (c) 1998, 1999 Epson Research and Development, Inc.
** All Rights Reserved.
**-----
**
** The data in this file was generated using 1375CFG.EXE.
**
** The configuration parameters chosen were:
**   320x240 Single Color 4-bit STN
**   4 bpp - 100 Hz Frame Rate (12 MHz CLKi)
**   High Performance enabled
**
**=====
*/
/*****
/* 13705 HAL HDR          (do not remove)          */
/* HAL_STRUCT Information generated by 1375CFG.EXE */
/* Copyright (c) 1998 Epson Research and Development, Inc. */
/* All rights reserved.                               */
/*                                                    */
/* Include this file ONCE in your primary source file */
/*****
HAL_STRUCT HalInfo =
{
  "13705 HAL EXE",      /* ID string */
  0x1234,              /* Detect Endian */
  sizeof(HAL_STRUCT), /* Size */
  0x00, 0x20, 0xC0, 0x03, 0x27, 0xEF, 0x00, 0x00,
  0x00, 0x00, 0x03, 0x00, 0x00, 0x00, 0x00, 0x00,
  0x00, 0x00, 0xFF, 0x03, 0x00, 0x00, 0x00, 0x00,
  0x00, 0x00, 0x00, 0x00, 0x00, 0x00, 0x00, 0x00,
  6000,                /* ClkI (kHz) */
  0xF00000,           /* Display Address */
  70,                 /* Panel Frame Rate (Hz) */
};
/*
**=====
** HAL_REGS.H
**-----
** Created 1998, Epson Research & Development
** Vancouver Design Center.
** Copyright(c) Seiko Epson Corp. 1998. All rights reserved.
**=====
*/
#ifndef HAL_REGS_H
#define HAL_REGS_H
/*
** 13705 register names
*/
#define REG_REVISION_CODE          0x00
#define REG_MODE_REGISTER_0       0x01
#define REG_MODE_REGISTER_1       0x02
#define REG_MODE_REGISTER_2       0x03
#define REG_HORZ_PANEL_SIZE        0x04
#define REG_VERT_PANEL_SIZE_LSB    0x05
#define REG_VERT_PANEL_SIZE_MSB    0x06
#define REG_FPLINE_START_POS       0x07
#define REG_HORZ_NONDISP_PERIOD    0x08
#define REG_FPFRAME_START_POS      0x09
#define REG_VERT_NONDISP_PERIOD    0x0A
#define REG_MOD_RATE               0x0B
#define REG_SCRN1_START_ADDR_LSB   0x0C

```

```

#define REG_SCRN1_START_ADDR_MSB          0x0D
#define REG_SCRN2_START_ADDR_LSB          0x0E
#define REG_SCRN2_START_ADDR_MSB          0x0F
#define REG_SCRN_START_ADDR_OVERFLOW      0x10
#define REG_MEMORY_ADDR_OFFSET            0x11
#define REG_SCRN1_VERT_SIZE_LSB            0x12
#define REG_SCRN1_VERT_SIZE_MSB            0x13
#define REG_LUT_ADDR                       0x15
#define REG_LUT_BANK_SELECT                 0x16
#define REG_LUT_DATA                        0x17
#define REG_GPIO_CONFIG                     0x18
#define REG_GPIO_STATUS                     0x19
#define REG_SCRATCHPAD                      0x1A
#define REG_PORTRAIT_MODE                   0x1B
#define REG_LINE_BYTE_COUNT                 0x1C
#define REG_NOT_PRESENT_1                   0x1D
/*
** WARNING!!! MAX_REG must be the last available register!!!
*/
#define MAX_REG                             0x1D
#endif          /* HAL_REGS_H */
/*-----
**
** Copyright (c) 1998, 1999 Epson Research and Development, Inc.
** All Rights Reserved.
**
** Module Name:
**
**   ioctl.h
**
**
** Abstract:
**
**   Include file for S1D13xxx PCI Board Driver.
**   Define the IOCTL codes we will use.  The IOCTL code contains a command
**   identifier, plus other information about the device, the type of access
**   with which the file must have been opened, and the type of buffering.
**
**-----
*/
#define SED_TYPE_FILE_DEVICE_CONTROLLER
// The IOCTL function codes from 0x800 to 0xFFF are for customer use.
#define IOCTL_SED_QUERY_NUMBER_OF_PCI_BOARDS \
    CTL_CODE( SED_TYPE, 0x900, METHOD_BUFFERED, FILE_ANY_ACCESS)
#define IOCTL_SED_MAP_PCI_BOARD \
    CTL_CODE( SED_TYPE, 0x901, METHOD_BUFFERED, FILE_ANY_ACCESS)
#define IOCTL_SED_MAP_PHYSICAL_MEMORY \
    CTL_CODE( SED_TYPE, 0x902, METHOD_BUFFERED, FILE_ANY_ACCESS)
#define IOCTL_SED_UNMAP_LINEAR_MEMORY \
    CTL_CODE( SED_TYPE, 0x903, METHOD_BUFFERED, FILE_ANY_ACCESS)

```

S1D13705F00A
Embedded Memory LCD Controller

Utilities

1	1375CFG CONFIGURATION PROGRAM	3-1
1.1	Introduction.....	3-1
1.2	Program Requirements	3-1
	Installation.....	3-1
	Usage.....	3-1
1.3	CFG Tab.....	3-2
	Panel Information.....	3-3
	Miscellaneous Options.....	3-5
	System.....	3-6
	LUT Control.....	3-7
	Message Bar.....	3-8
1.4	REGS Tab.....	3-9
1.5	Buttons	3-10
	Open.....	3-10
	Save.....	3-11
	Help.....	3-11
	Exit.....	3-11
1.6	Comments.....	3-12
2	1375SHOW DEMONSTRATION PROGRAM.....	3-13
2.1	1375SHOW.....	3-13
	S1D13705 Supported Evaluation Platforms	3-13
	Installation.....	3-13
	Usage.....	3-14
	Comments.....	3-14
	Program Messages.....	3-15
3	1375SPLT DISPLAY UTILITY.....	3-16
3.1	1375SPLT	3-16
	S1D13705 Supported Evaluation Platforms	3-16
	Installation.....	3-16
	Usage.....	3-17
	1375SPLT Example	3-17
	Program Messages.....	3-18
4	1375VIRT DISPLAY UTILITY.....	3-19
4.1	1375VIRT	3-19
	S1D13705 Supported Evaluation Platforms	3-19
	Installation.....	3-19
	Usage.....	3-20
	1375VIRT Example.....	3-20
	Program Messages.....	3-21
5	1375PLAY DIAGNOSTIC UTILITY	3-22
5.1	1375PLAY	3-22
	S1D13705 Supported Evaluation Platforms	3-22
	Installation.....	3-22
	Usage.....	3-23
	1375PLAY Example.....	3-24
	Scripting.....	3-24
	Comments.....	3-24
	Program Messages.....	3-25
6	1375BMP DEMONSTRATION PROGRAM	3-26
6.1	1375BMP.....	3-26
	Installation.....	3-26

Usage	3-26
Comments	3-26
Program Messages.....	3-27
7 1375PWR POWER SAVE UTILITY	3-28
7.1 1375PWR.....	3-28
S1D13705 Supported Evaluation Platforms	3-28
Installation.....	3-28
Usage	3-29
Program Messages.....	3-29

List of Figures

Figure 1-1	1375CFG Window	3-2
Figure 1-2	Panel Information	3-3
Figure 1-3	Miscellaneous Options	3-5
Figure 1-4	System Options	3-6
Figure 1-5	ERROR: Frame Rate	3-6
Figure 1-6	ERROR: Zero Frame Rate	3-6
Figure 1-7	Look-Up Table Control	3-7
Figure 1-8	REGS Window	3-9
Figure 1-9	1375CFG File Open Dialog	3-10
Figure 1-10	ERROR: Unable to read HAL	3-10
Figure 1-11	1375CFG Save As Dialog	3-11
Figure 1-12	ERROR: Unable to read HAL	3-11

List of Table

Table 1-1	MCLK to PCLK Ratios	3-5
-----------	---------------------------	-----

1 1375CFG CONFIGURATION PROGRAM

1.1 Introduction

1375CFG is 32-bit Windows program designed to calculate register values for the S1D13705. The user enters data such as the input clock frequency, panel width and height, and other panel specific information. After calculating the register values the information can be used to configure executable files based on the S1D13705 Hardware Abstraction Layer (HAL) or written to ASCII text files.

1375CFG can:

- Read programs, based on the S1D13705 HAL, modify the settings and write the changes back to the file. The ability to read, modify and write executable files bypasses having to recompile after configuration changes.
- Write C header files containing register settings which then can be used to initialize the S1D13705 registers in programs which do not use the HAL.
- Write ASCII text files containing a list of the registers and the register values and the input clock and frame rate the register calculations are based on.

1.2 Program Requirements

This program is designed to run under Windows 95/98 or Windows NT.

Installation

There is no installation program for 1375CFG. Installation to a local drive is done by copying 1375CFG.EXE and 1375CFG.HLP to your hard drive and optionally creating a link on the Windows desktop for easy access to the program.

Usage

Open the drive and folder where you copied 1375CFG.EXE and double click the icon to start the program. Optionally, if you created a link to the program on your desktop, double click the link icon.

After starting you will be presented with a tabbed dialog box containing four buttons and two tabs: CFG and REGS. The following sections will describe the using the tabs followed by a description of the buttons.

1.3 CFG Tab

Upon opening 1375CFG the user is present with a window which appears as in Figure 1-1.

The CFG tab is the dominant portion of the window and consists of four main sections: Panel information (includes Dimensions), Look-Up Table, Miscellaneous Options, and System settings. Each of these sections will be discussed in detail.

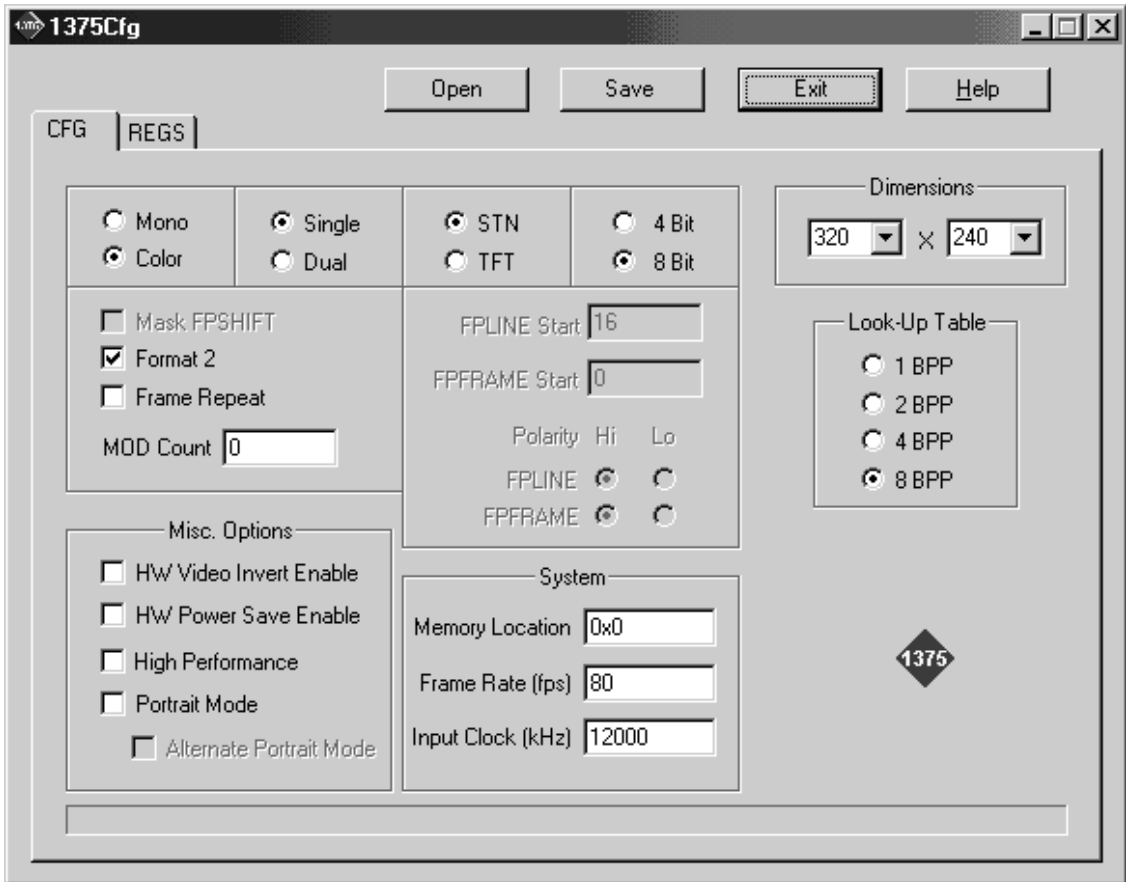

Figure 1-1 1375CFG Window

Panel Information

Figure 1-2 Panel Information

The panel information portion of CFG tab describes the panel to be connected to the S1D13705.

This section of the 1375CFG dialog describes the panel connected to the S1D13705. Each of the settings are described briefly below.

- **Mono / Color** - selects whether the attached panel is monochrome or color.
Select mono for monochrome panels or color for color panels. This option is STN specific and is disabled if TFT is selected.
- **Single / Dual** - selects whether the panel is a single STN or dual STN.
Select single for a single panel or dual for a dual panel. This option is STN specific and is disabled if TFT is selected.
- **STN / TFT** - determines the technology used to construct the panel.
Select STN for passive panels or TFT for active panels. Selecting STN enables all the STN options and disables (grays out) the TFT specific settings. Selecting TFT enables the TFT settings and disables STN specific settings.
- **4 Bit / 8 Bit** - these setting select the data width the panel requires.
These radio buttons are STN/TFT specific. When STN is selected the options are “4 Bit” and “8 Bit”. Selecting a TFT type panel changes these options to “9 Bit” and “12 Bit”. Select the data width as appropriate for your panel.
Note:panel data width is not the same as color depth.
- **Dimensions** - the two boxes in the upper right corner of the CFG tab allow selecting the panel dimensions.
In the left selection box enter the panel width in pixels and in the right selection box enter the panel height in pixels.
Values in the selection boxes can be either chosen from the drop-down list or typed directly into the edit portion of the selection box.
- **Mask FPSHIFT** - when selected causes the signal FPSHIFT to be masked.
This option is required by most newer monochrome panels. Whenever either color panel or TFT is selected this option is disabled.

- **Format 2** - determines the data clocking format for “8 Bit” single color panels.
8-bit single color panels typically use one of two data clocking formats arbitrarily named “format 1” and “format 2”. Selecting “format 2” instructs the S1D13705 to use the second color panel data format.
Most newer panels and, to date, all color panels smaller than 640x480 use “format 2”. Setting this attribute incorrectly will result in a garbled display but will not damage the panel. The display may appear “cut in half” or possibly horizontally skewed.
This option is STN specific and is disabled if TFT is selected. It is also disabled if the panel type selected to be 4-bit data or monochrome.
- **Frame Repeat** - is a feature for EL panel support.
EL panels require a frame of repeated data as the cue to switch polarization. Without this change in polarization panel quality deteriorates.
When Frame Repeat is selected an internal counter causes the periodic repeat of one frame of modulated panel data. At a frame rate of 72 Hz the repeat period is roughly one hour. When not selected the modulated image is never consecutively repeated.
This option is STN specific and is disabled if TFT is selected.
- **MOD Count** - specifies the number of FPLINE pulses between toggles of the MOD signal.
This setting is for passive panels only and is generally only required for older monochrome panels. When set to “0” (default) the MOD output signal toggles every FPFRAME.
- **FPLINE Start** - specifies the delay, in 8 pixel resolution, from the end of a line of display data (FPDAT) to the leading edge of FPLINE.
This field is a TFT specific setting and is disabled if an STN panel is chosen.
- **FPFRAME Start** - specifies the number of lines between the last line of display data (FPDAT) and the leading edge of FPFRAME.
This field is a TFT specific setting and is disabled if an STN panel is chosen.
- **FPLINE / FPFRAME Polarity** - these settings control the sync pulse direction of the FPLINE and FPFRAME pulses in TFT modes.
Select the appropriate pulse direction for the panel being connected. Selecting 'Lo' results in an active low sync pulse while 'Hi' results in an active high pulse.
These settings are TFT specific and are disabled when STN panel is selected. When an STN panel type is selected the pulse directions are preset to +ve, +ve.

Miscellaneous Options

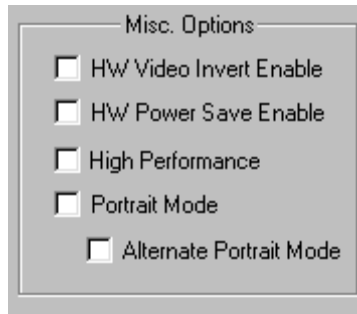

Figure 1-3 Miscellaneous Options

Miscellaneous options cover several items which do not fit into other categories.

- **HW Video Invert Enable** - when selected, enables the hardware video invert capability of the S1D13705.

The S1D13705 supports inverted color output. The color inversion can be toggled by software or in response to a signal applied to pin FPDAT11. In order for the hardware color inversion to succeed this option must be selected, or the software must enable this feature at run time.

There are two methods of performing color inversion. In the first scheme the display memory data is inverted and the resulting color is derived from the corresponding Look-Up Table element. (i.e. the inverse of color 0 would be whatever color was LUT[FF] was set to. If element 0 and FF were both set to set to White then we would observe the inverse of white as being white). The second scheme is to invert the data as it comes out of the Look-Up Table resulting in a true color inversion. The S1D13705 uses the second method.

TFT panels require all the FPDAT control lines, as a result hardware color inversion is not possible when using TFT panels. Software invoked color inversion can be invoked when using TFT panels.

- **HW Power Save Enable** - select this option to enable hardware invoked power save modes.

The S1D13705 supports two means of invoking a power save mode. In response to a software effected change or in response to input on the GPIO0 pin. In order for the hardware power save mode to function this option must be selected.

- **High Performance** - improves chip throughput at the expense of power consumption.

When not selected the memory clock (MCLK) signal is a divided down version of the pixel clock (PCLK) signal. Table 1 depicts the ratios when high performance is not selected.

With slower MCLK selections comes lower performance and also lower power use. This setting allows the user to trade off power consumption for system performance.

Table 1-1 MCLK to PCLK Ratios

Color Depth (bpp)	Ratio
1	MCLK = PCLK / 8
2	MCLK = PCLK / 4
4	MCLK = PCLK / 2
8	MCLK = PCLK

Selecting this option result in MCLK equalling PCLK at all display resolution. Overall performance is increased but so is power consumption.

- **SwivelView Mode** - selecting this option causes register settings and timings to be saved for SwivelView mode operation.

- **Alternate SwivelView Mode** - selects the alternate mode.

The S1D13705 supports two SwivelView mode schemes. Default SwivelView mode offers slightly slower performance with the gain of lower power consumption. Alternate SwivelView mode is more flexible and slightly faster at the expense of drawing more power.

This option is only enable if SwivelView Mode is selected.

Note: The SwivelView mode settings are intended primarily for the case where a developer desires a C header file set of register values for his own program.

The HAL is capable of performing rotations “on the fly”. Most programs written for the HAL will ignore this setting and set SwivelView or Landscape display modes as instructed by the user.

System

The options in the System section describe the items which are required for frame rate calculations and the location in CPU address space where the S1D13705 will be located.

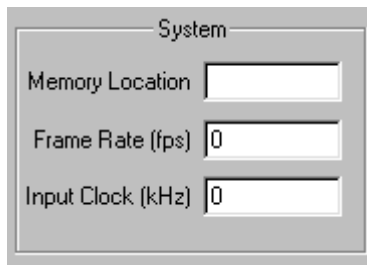

Figure 1-4 System Options

- **Memory Location** - this describes where in CPU address space the S1D13705 will be located. This setting is required by the HAL to locate the S1D13705.
- **Frame Rate** - indicates the desired frame rate. 1375CFG will attempt to write register settings which result in the requested frame rate. If the frame rate cannot be reached then the following dialog inform the user of the problem.



Figure 1-5 ERROR: Frame Rate

A Frame rate must be entered in order for 1375CFG to complete the frame rate calculations. If no frame rate is entered or the frame rate is set to 0 then the following dialog box will inform the user when they try to save the configuration.

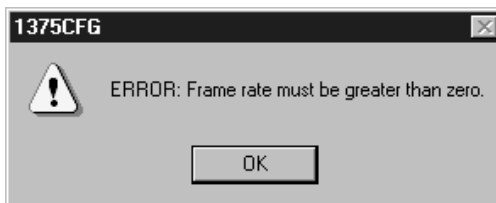

Figure 1-6 ERROR: Zero Frame Rate

- **Input Clock** - this field specifies the input clock being applied to the S1D13705 in kHz.

LUT Control

This section controls the color depth for the S1D13705 after initialization.



Figure 1-7 Look-Up Table Control

Select the desired color depth from the available options.

Color depth selections in this section are enabled or disabled dependent upon the selected panel dimensions. i.e. there is only enough memory to operate a 640x480 panel at 2 bit per pixel so the selections for 4 BPP and 8 BPP would be disabled when this panel size is selected.

Note: The primary use for the Look-Up Table color depth settings are for a developer to derive a set of register values for inclusion in a program. Most of the sample programs based on the HAL override the color depth for testing purposes.

Message Bar



The message bar is used to convey configuration information to the person using 1375CFG. These messages are intended to help the user in derive the best possible configuration. Currently there are three messages which may appear here:

- Warning: HNDP (???) is getting quite large.

This message is declaring the Horizontal Non-Display Period is getting quite large

1375CFG uses a loop to determine the best values for both horizontal and vertical non-display periods. If the horizontal non-display period grows excessively large (greater than 160 pixels) as result of the calculations this message is issued.

Larger HNDP values usually result in fading of the display image. Try increasing the frame rate or reducing the input clock to correct this problem.

This warning may be ignored with the understanding that there may be a display image degradation.

- Warning: VNDP (???) is getting quite large.

This message is declaring the Vertical Non-Display Period is getting quite large. The value (???) is the VNDP that 13705 has calculated.

1375CFG uses a loop to determine the best values for both horizontal and vertical non-display periods. If the vertical non-display period grows excessively large (greater than 30 lines) as result of the calculations this message is issued.

Larger VNDP values may result in image tearing, jitter or other display anomalies. Try increasing the frame rate or reducing the input clock to correct this problem.

This warning may be ignored with the understanding that there may be a display image degradation.

- Warning: unable to set the frame rate based on the current settings.

Based on the current setting for horizontal and vertical size, input clock and desired frame rate it is not possible to calculate a combination of horizontal and vertical non-display times to satisfy the requested frame rate.

Typical causes for this message are incorrect input clock or frame rate values. The values may be excessively high or excessively low. Correct the suspect value before attempting to save the configuration.

If this warning is ignored it will lead to the message box shown in Figure 1-5 on page 3-6 or Figure 1-6 on page 3-6 being displayed when the “Save” button is clicked.

1.4 REGS Tab

The REGS tab displays the register values derived after converting the information on the CFG page in to register values.

The automatic calculations may not result in precisely the register values required for a specific use. For instance the HNDP or VNDP values may have to be tweaked for a particular panel. From this page the user can set specific register to specific values.

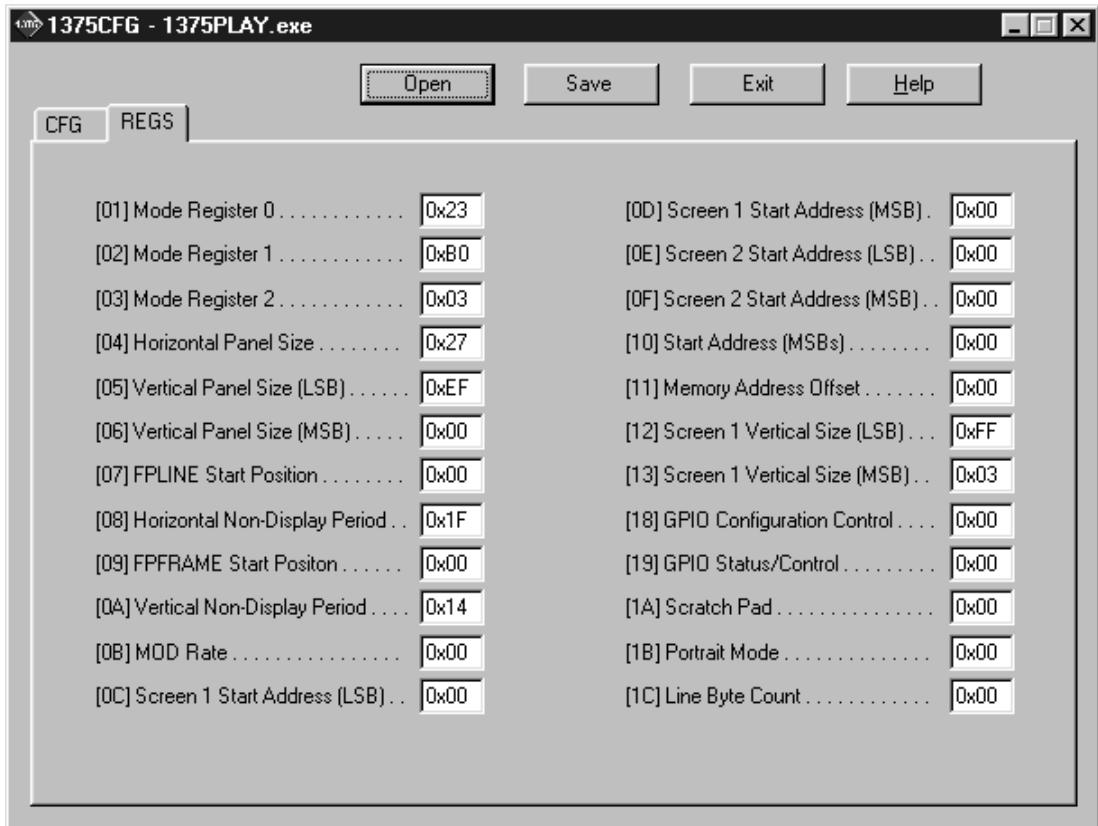

Figure 1-8 REGS Window

Not all the S1D13705 registers are represented on this page. For example; it makes no sense to represent REG[00], the Revision Code, which is read only. Nor are the Look-Up Table registers, REG[15] and REG[17], as they must be specially handled by the application after the majority of the S1D13705 registers have been initialized.

Typical use of 1375CFG involves using the CFG page to quickly set register values. After performing the initial setup on the CFG page the user should switch to the REGS page and perform any register adjusting that must be done.

IMPORTANT: do *not* return to the CFG page after making register adjustments on this page. Doing so will result in an automatic recalculation of some register values and the possible loss of adjusted settings.

1.5 Buttons

Outside of the page area of 1375CFG there are four buttons for reading and writing files, obtaining help or for exiting the program. The following sections describe these buttons.

Open

Click the Open button to read the settings saved in an executable program based on the S1D13705 hardware abstraction layer.

Clicking the Open button brings up the standard Windows file open dialog.

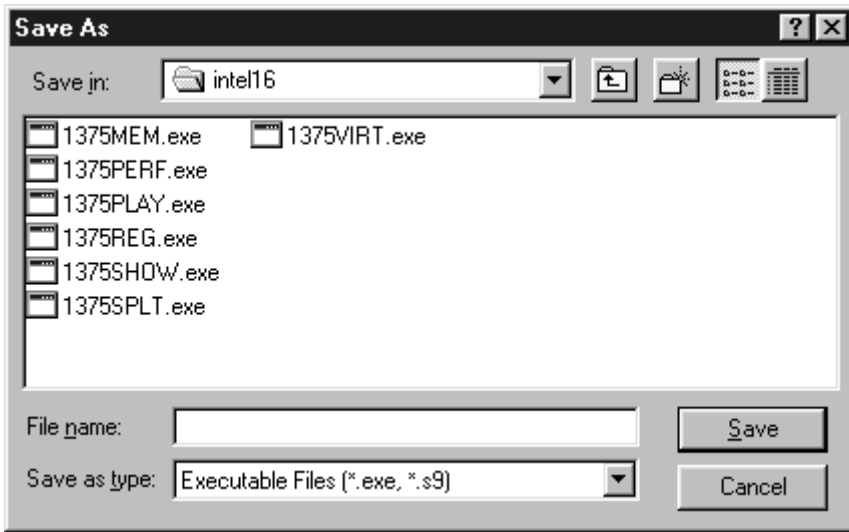

Figure 1-9 1375CFG File Open Dialog

From here the user selects the file to be opened. 1375CFG is capable of opening executable files based on the S1D13705 HAL. Typically the file extension for these file are .EXE for intel platform executables and .S9 for 68k and SH3 platform executables.

Opening a file reads that files HAL configuration information. Use the data read as a starting point in configuring this or other files or to check on the current configuration.

If 1375CFG is unable locate the HAL information in the selected file the following dialog box is displayed.

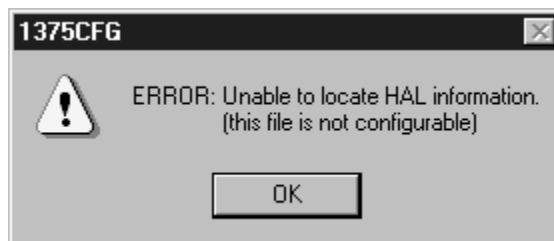

Figure 1-10 ERROR: Unable to read HAL

Save

Click the Save button to save the current configuration settings. When clicked the standard Windows file “Save As” dialog box is displayed.

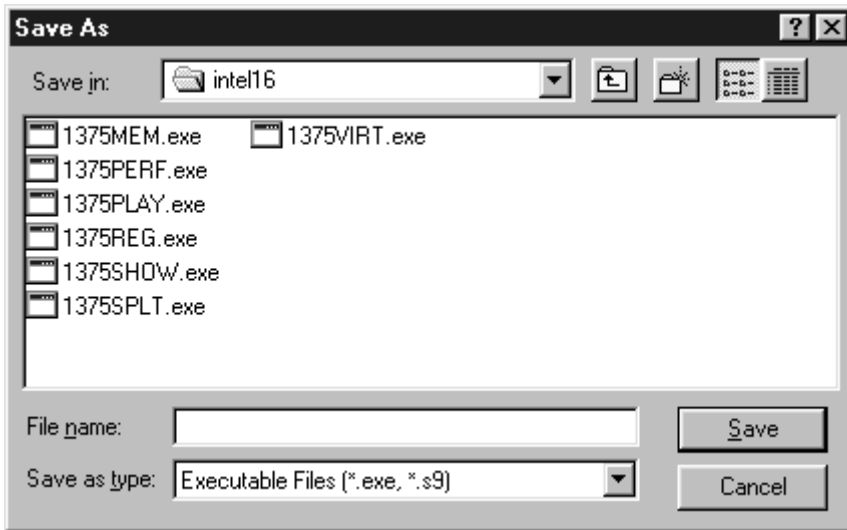

Figure 1-11 1375CFG Save As Dialog

From the save as dialog box first select the type of file to save to in the “Save as type:” edit field. 1375CFG currently saves in three file formats.

- .EXE files - are binary images containing a HAL structure for execution on Intel platforms
- .S9 files - are ASCII binary format files used by several embedded systems. The .S9 file is a variation of S19 files.
- .H files - are ASCII C header files which can be included in other programs.

If an executable file (.EXE or .S9) is selected as the type of file to save to the file being saved to must already exist and be an S1D13705 HAL based program. 1375CFG is cannot save to a non-existent program. If 1375CFG is unable to locate the HAL information in the file being saved to the following dialog box is displayed.

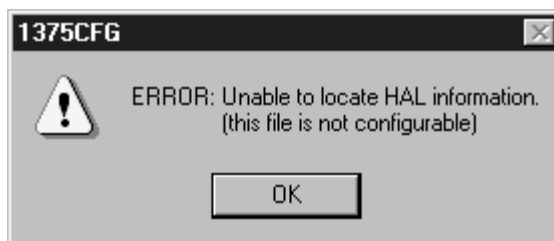

Figure 1-12 ERROR: Unable to read HAL

Help

Clicking on the Help button will start the help file for 1375CFG.

Exit

Clicking on the Exit button exits 1375CFG immediately. The user is not prompted to save any changes they may have made.

1.6 Comments

It is assumed that the 1375CFG user is familiar with S1D13705 hardware and software. Refer to the “*S1D13705 Hardware Functional Specification*” drawing office number X27A-A-001-02, and the “*S1D13705 Programming Notes and Examples*” manual, drawing office number X27A-G-002-01 for information.

2 1375SHOW DEMONSTRATION PROGRAM

2.1 1375SHOW

1375SHOW is a program designed to demonstrate rudimentary display capabilities of the S1D13705. The display abilities are shown by drawing a pattern image to the video display at all supported color depths (1, 2, 4 and 8 bits-per-pixel)

The 1375SHOW display utility must be configured and/or compiled to work with your hardware platform. The program 1375CFG.EXE can be used to configure 1375SHOW. Consult the “1375CFG CONFIGURATION PROGRAM”, document number X27A-B-001-01, for more information on configuring S1D13705 utilities.

This software is designed to work in both embedded and personal computer (PC) environments. For the embedded environment, it is assumed that the system has a means of downloading software from the PC to the target platform. Typically, this is done by serial communications. The PC uses a terminal program to send control commands and information to the target processor. Alternatively, the PC can program an EPROM, which is then placed in the target platform. Some target platforms can also communicate with the PC via a parallel port connection, or an Ethernet connection.

S1D13705 Supported Evaluation Platforms

1375SHOW has been tested with the following S1D13705 supported evaluation platforms:

- PC system with an x86 processor. Both 16-bit and 32-bit code is supported.
- M68EC000IDP (Integrated Development Platform) board, revision 3.0, with a Motorola M68EC000 processor.
- SH3-LCEVB board, revision B, with an Hitachi SH-3 HD6417780 processor.

If the platform you are using is different from the above, please see the “*S1D13705 Programming Notes and Examples*” manual, document number X26A-G-002-01.

Installation

PC Intel Platform

For 16-Bit Program Version: copy the file 1375SHOW.EXE to a directory that is in the DOS path on your hard drive.

For 32-Bit Program Version: install the 32-bit Windows device driver S1D13XXX.VXD as described in the “*S1D13XXX 32-Bit Windows Device Driver Installation Guide*”, document number X00A-E-003-xx. Copy the file 1375SHOW.EXE to a directory that is in the DOS path on your hard drive.

Embedded Platform

Download the program 1375SHOW to the system.

Usage

PC platform: at the prompt, type:

```
1375show [/a][b=n][/l][/p [/alt]][/vertical][/noinit][/?]
```

Embedded platform: execute 1375show and at the prompt, type the command line argument(s).

Where:	/a	automatically cycle through all video modes.
	b=?	starts 1375SHOW at a user specified bit-per-pixel (bpp) level, where ? can be: 1, 2, 4, or 8.
	/l	set landscape mode.
	/p	set portrait mode.
	/alt	use alternate portrait mode
	/vertical	displays vertical line pattern.
	/update	continuously update display memory.
	/noinit	bypass register initialization and use values which are currently in the registers.
	/?	displays the help screen.

Comments

- The /alt command line switch can only be used with the /p (portrait) mode switch. This switch will have no effect in landscape display modes.
- The Intel 32-bit version of 1375SHOW is designed to work under either Windows 9x or Windows NT. To install the 32-bit Windows device driver S1D13XXX.vxd see the “*S1D13XXX 32-Bit Windows Device Driver Installation Guide*”, document number X00A-E-003-xx.

The 16-bit version of the program runs under DOS with no DOS extenders. The lack of a DOS extender means that the 16-bit program can only be used on a hardware platform where the S1D13705 is addressed below 1MB.

Program Messages

ERROR: Did not find a 13705 device.

The HAL was unable to read the revision code register on the S1D13705. Ensure that the S1D13705 hardware is installed and that the hardware platform has been configured correctly. Also check that the display memory address has been configured correctly.

ERROR: Unable to locate/load S1D13XXX.VXD

1375PLAY was unable to load a required driver. The file S1D13XXX.VXD should be located in x:\WINDOWS\SYSTEM or in x:\WINNT\SYSTEM. If the file is not there, install it as described in the S1D13XXX 32-Bit Windows Device Driver Installation Guide, document number X00A-E-003-xx.

ERROR: An IOCTL error occurred

This message indicates an error at the IO control layer occurred. The usual cause for this is an incorrect hardware configuration.

ERROR: The HAL returned an unknown error

This message should never be displayed, it indicates that 1375SHOW is unable to determine the cause of an error returned from the HAL.

ERROR: Could not initialize device

The call to initialize the S1D13705 registers failed.

Not enough memory for www x hhh x bpp!!

This message is printed if there is insufficient display memory to show a complete image with a width of www pixels, a height of hhh pixels and a color depth of bpp bit-per-pixel. In this case the mode is skipped and the next display mode is attempted.

3 *1375SPLT DISPLAY UTILITY*

3.1 *1375SPLT*

1375SPLT demonstrates S1D13705 split screen capability by showing two different areas of display memory on the screen simultaneously.

Screen 1 memory is located at the start of the display buffer and is filled with horizontal bars. Screen 2 memory is located immediately after Screen 1 in the display buffer and is filled with vertical bars. On either user input or elapsed time, the line compare register value is changed to adjust the amount of display area taken up by each screen.

The 1375SPLT display utility must be configured and/or compiled to work with your hardware platform. The program 1375CFG.EXE can be used to configure 1375SPLT. Consult the “*1375CFG CONFIGURATION PROGRAM*”, document number X27A-B-001-01, for more information on configuring S1D13705 utilities.

This software is designed to work in both embedded and personal computer (PC) environments. For the embedded environment, it is assumed that the system has a means of downloading software from the PC to the target platform. Typically, this is done by serial communications. The PC uses a terminal program to send control commands and information to the target processor. Alternatively, the PC can program an EPROM, which is then placed in the target platform. Some target platforms can also communicate with the PC via a parallel port connection, or an Ethernet connection.

S1D13705 Supported Evaluation Platforms

1375SPLT has been tested with the following S1D13705 supported evaluation platforms:

- PC system with an x86 processor. Both 16-bit and 32-bit code is supported.
- M68EC000IDP (Integrated Development Platform) board, revision 3.0, with a Motorola M68EC000 processor.
- SH3-LCEVB board, revision B, with an Hitachi SH-3 HD6417780 processor.

If the platform you are using is different from the above, please see the “*S1D13705 Programming Notes and Examples manual*”, document number X26A-G-002-01.

Installation

PC Intel Platform

For 16-Bit Program Version: copy the file 1375SPLT.EXE to a directory that is in the DOS path on your hard drive.

For 32-Bit Program Version: install the 32-bit Windows device driver S1D13XXX.VXD as described in the S1D13XXX 32-Bit Windows Device Driver Installation Guide, document number X00A-E-003-xx. Copy the file 1375SPLT.EXE to a directory that is in the DOS path on your hard drive.

Embedded Platform

Download the program 1375SPLT to the system.

Usage

PC platform: at the prompt, type **1375SPLT [/a] [/?]**

Embedded platform: execute **1375spl**t and at the prompt, type the command line argument.

Where :	no argument	enables manual split screen operation
	/a	enables automatic split screen operation (a timer is used to move screen 2)
	/?	display the help screen

After starting 1375SPLT the following keyboard commands are available.

Manual mode:	↑, u	move Screen 2 up
	↓, d	move Screen 2 down
	HOME	covers Screen 1 with Screen 2
	END	displays only Screen 1
Automatic mode:	any key	change the direction of split screen movement (for PC only)
Both modes:	b	changes the color depth (bits-per-pixel)
	ESC	exits 1375SPLT

1375SPLT Example

1. Type “1375spl /a” to automatically move the split screen.
2. Press “b” to change the color depth from 1 bit-per-pixel to 2 bit-per-pixel.
3. Repeat step 2 for the remaining color depths (4 and 8 bit-per-pixel).
4. Press <ESC> to exit the program.

Program Messages

ERROR: Did not find a 13705 device.

The HAL was unable to read the revision code register on the S1D13705. Ensure that the S1D13705 hardware is installed and that the hardware platform has been configured correctly. Also check that the display memory address has been configured correctly.

ERROR: Unable to locate/load S1D13XXX.VXD

1375PLAY was unable to load a required driver. The file S1D13XXX.VXD should be located in x:\WINDOWS\SYSTEM or in x:\WINNT\SYSTEM. If the file is not there, install it as described in the S1D13XXX 32-Bit Windows Device Driver Installation Guide, document number X00A-E-003-xx.

ERROR: An IOCTL error occurred

This message indicates an error at the IO control layer occurred. The usual cause for this is an incorrect hardware configuration.

ERROR: The HAL returned an unknown error

This message should never be displayed, it indicates that 13705SOLT is unable to determine the cause of an error returned from the HAL.

Not enough memory for www x hhh x bpp!!

This message is displayed if there is insufficient display memory to contain two complete images with a width of www pixels, a height of hhh pixels, and a color depth of bpp bit-per-pixel. In this case the mode is skipped and the next display mode is attempted.

4 1375VIRT DISPLAY UTILITY

4.1 1375VIRT

1375VIRT demonstrates the virtual display capability of the S1D13705. A virtual display is where the image to be displayed is larger than the physical display device. The display surface is used as a viewing window. The entire image can be seen only by panning and scrolling.

The 1375VIRT display utility must be configured and/or compiled to work with your hardware platform. The program 1375CFG.EXE can be used to configure 1375VIRT. Consult the “1375CFG CONFIGURATION PROGRAM”, document number X27A-B-001-01, for more information on configuring S1D13705 utilities.

This software is designed to work in both embedded and personal computer (PC) environments. For the embedded environment, it is assumed that the system has a means of downloading software from the PC to the target platform. Typically, this is done by serial communications. The PC uses a terminal program to send control commands and information to the target processor. Alternatively, the PC can program an EPROM, which is then placed in the target platform. Some target platforms can also communicate with the PC via a parallel port connection, or an Ethernet connection.

S1D13705 Supported Evaluation Platforms

1375VIRT has been tested with the following S1D13705 supported evaluation platforms:

- PC system with an x86 processor.
- M68EC000IDP (Integrated Development Platform) board, revision 3.0, with a Motorola M68EC000 processor.
- SH3-LCEVB board, revision B, with an Hitachi SH-3 HD6417780 processor.

If the platform you are using is different from the above, please see the “S1D13705 Programming Notes and Examples” manual, document number X26A-G-002-01.

Installation

PC Intel Platform

For 16-Bit Program Version: copy the file 1375VIRT.EXE to a directory that is in the DOS path on your hard drive.

For 32-Bit Program Version: install the 32-bit Windows device driver S1D13XXX.VXD as described in the “S1D13XXX 32-Bit Windows Device Driver Installation Guide”, document number X00A-E-003-xx. Copy the file 1375VIRT.EXE to a directory that is in the DOS path on your hard drive.

Embedded Platform

Download the program 1375VIRT to the system.

Usage

PC platform: at the prompt, type `1375virt [/a] [/l] [/p] [/alt] [/w=???`.

Embedded platform: execute `1375virt` and at the prompt, type the command line argument.

Where:

no argument	panning and scrolling is performed manually (defaults to virtual width = physical width x 2 and maximum virtual height)
/a	panning and scrolling is performed automatically
/l	Force landscape display mode to be set
/p	Force portrait display mode to be set
/alt	Enable alternate portrait mode. Selecting this option implies /p
/w=???	specifies the virtual display width which includes both on-screen and off-screen size

the maximum virtual width, not including display area, for each display mode is:

- 1 bpp – 4096 pixels
- 2 bpp – 2048 pixels
- 4 bpp – 1024 pixels
- 8 bpp – 512 pixels

The following keyboard commands are for navigation within the program.

Manual mode:	↑	scrolls up
	↓	scrolls down
	←	pans to the left
	→	pans to the right
	HOME	moves the display screen so that the upper right of the virtual screen shows in the upper right of the display
	END	moves the display screen so that the lower left of the virtual screen shows in the lower left of the display
Automatic mode:	any key	changes the direction of screen
Both modes:	b	changes the color depth (bits-per-pixel)
	ESC	exits 1375VIRT

1375VIRT Example

5. Type “1375virt /a” to automatically pan and scroll.
6. Press "b" to change the bits-per-pixel from 1 bit-per-pixel to 2 bits-per-pixel.
7. Repeat steps 1 and 2 for the remaining color depths (4 and 8 bit-per-pixel).
8. Press <ESC> to exit the program.

Program Messages

ERROR: Did not find a 13705 device.

The HAL was unable to read the revision code register on the S1D13705. Ensure that the S1D13705 hardware is installed and that the hardware platform has been configured correctly. Also check that the display memory address has been configured correctly.

ERROR: Unable to locate/load S1D13XXX.VXD

1375PLAY was unable to load a required driver. The file S1D13XXX.VXD should be located in x:\WINDOWS\SYSTEM or in x:\WINNT\SYSTEM. If the file is not there, install it as described in the S1D13XXX 32-Bit Windows Device Driver Installation Guide, document number X00A-E-003-xx.

ERROR: An IOCTL error occurred

This message indicates an error at the IO control layer occurred. The usual cause for this is an incorrect hardware configuration.

ERROR: The HAL returned an unknown error

This message should never be displayed, it indicates that 1375VIRT is unable to determine the cause of an error returned from the HAL.

Unable to use virtual mode at xx BPP

This message is displayed if there is insufficient display memory to show a complete virtual image. Specifically, the maximum number of lines for the image is calculated using the current virtual width. If the number of possible lines is less than the physical display size this message is displayed. Try restarting the program and manually specify a smaller virtual width.

5 1375PLAY DIAGNOSTIC UTILITY

5.1 1375PLAY

1375PLAY is a utility which allows the user to easily read/write the S1D13705 registers, Look-Up Table and display memory.

The user interface for 1375PLAY is similar to the DOS DEBUG program; commands are received from the standard input device, and output is sent to the standard output device (console for Intel and terminal for embedded platforms). This utility requires the target platform to support standard IO.

1375PLAY commands can be entered interactively using a keyboard/monitor or they can be executed from a script file. Scripting is a powerful feature which allows command sequences played back from a file thus avoiding having to retype lengthy sequences.

The 1375PLAY display utility must be configured and/or compiled to work with your hardware platform. The program 1375CFG.EXE can be used to configure 1375PLAY. Consult the “*1375CFG CONFIGURATION PROGRAM*”, document number X27A-B-001-01, for more information on configuring S1D13705 utilities.

This software is designed to work in both embedded and personal computer (PC) environments. For the embedded environment, it is assumed that the system has a means of downloading software from the PC to the target platform. Typically, this is done by serial communications. The PC uses a terminal program to send control commands and information to the target processor. Alternatively, the PC can program an EPROM, which is then placed in the target platform. Some target platforms can also communicate with the PC via a parallel port connection, or an Ethernet connection.

S1D13705 Supported Evaluation Platforms

1375PLAY has been tested with the following S1D13705 supported evaluation platforms:

- PC system with an x86 processor. Both 16-bit and 32-bit code is supported.
- M68EC000IDP (Integrated Development Platform) board, revision 3.0, with a Motorola M68EC000 processor.
- SH3-LCEVB board, revision B, with an Hitachi SH-3 HD6417780 processor.

If the platform you are using is different from the above, please see the “*S1D13705 Programming Notes and Examples*” manual, document number X26A-G-002-01.

Installation

PC Intel Platform

For 16-Bit Program Version: copy the file 1375PLAY.EXE to a directory that is in the DOS path on your hard drive.

For 32-Bit Program Version: install the 32-bit Windows device driver S1D13XXX.VXD as described in the “*S1D13XXX 32-Bit Windows Device Driver Installation Guide*”, document number X00A-E-003-xx. Copy the file 1375PLAY.EXE to a directory that is in the DOS path on your hard drive.

Embedded Platform

Download the program 1375PLAY to the system.

Usage

PC platform: at the prompt, type **1375play** [/?].

Embedded platform: execute **1375play** and at the prompt, type the command line argument.

Where: /? displays program revision information.

The following commands are valid within the 1375PLAY program.

X index [data]	Reads/writes the registers. Writes data to the register specified by the index when “data” is specified; otherwise the register is read.
XA	Reads all registers.
L index [data1 data2 data3]	Reads/writes Look-Up Table (LUT) values. Writes data to the LUT index when “data” is specified; otherwise the LUT index is read. Data must consist of 3 bytes: 1 red, 1 green, 1 blue. and range in value from 0x00 to 0x0F.
LA	Reads all LUT values.
F[W] addr1 addr2 data . . .	Fills bytes or words from address 1 to address 2 with data. Data can be multiple values (e.g. F 0 20 1 2 3 4 fills address 0 to 0x20 with a repeating pattern of 1 2 3 4) .
R[W] addr [count]	Reads “count” of bytes or words from the address specified by “addr”. If “count” is not specified, then 16 bytes/words are read.
W[W] addr data . . .	Writes bytes or words of data to address specified by “addr”. Data can be multiple values (e.g. W 0 1 2 3 4 writes the byte values 1 2 3 4 starting at address 0) .
I	Initializes the chip with user specified configuration.
M [bpp]	Returns information about the current mode. If “bpp” is specified then set the requested color depth.
P 0 1 2	Sets software power save mode 0-2. Power save mode 0 is normal operation.
H [lines]	Halts after specified lines of display. This feature halts the display during long read operations to prevent data from scrolling off the display. Set 0 to disable.
Q	Quits this utility.
?	Displays Help information.

1375PLAY Example

Type "1375PLAY" to start the program.

Type "?" for help.

Type "i" to initialize the registers.

Type "xa" to display the contents of the registers.

Type "x 5" to read register 5.

Type "x 3 10" to write 10 hex to register 3.

Type "f 0 ffff aa" to fill the first FFFF hex bytes of display memory with AA hex.

Type "f 0 1ffff aa" to fill 2M bytes of display memory.

Type "r 0 ff" to read the first 100 hex bytes of display memory.

Type "q" to exit the program.

Scripting

1375PLAY can be driven by a script file. This is useful when:

- there is no standard display output to monitor command entry and results.
- various registers must be quickly changed faster than can be achieved by typing.
- The same series of keystrokes is being entered time and again.

A script file is an ASCII text file with one 1375PLAY command per line. All scripts must end with a "q" (quit) command in order to return control to the operating system. The semi-colon is used as a comment delimiter. Everything on a line after the semi-colon will be ignored.

On a PC platform, a typical script command line is: "1375PLAY < dumpregs.scr > results".

This causes the script file "dumpregs.scr" to be interpreted and the results to be sent to the file "results."

Example 1 : The script file "dumpregs.scr" can be created with a text editor and will look like the following:

```
; This file initializes the S1D13705 and reads the registers  
i;   Initialize the registers.  
xa;  Dump all the registers  
la;  And the LUT  
q;   Exit
```

Comments

- All numeric values are considered to be hexadecimal unless identified otherwise. For example, 10 = 10h = 16 decimal; 10t = 10 decimal; 010b = 2 decimal.
- Redirecting commands from a script file (PC platform) allows those commands to be executed as though they were typed.

Program Messages

>>> **WARNING: DID NOT DETECT S1D13705** <<<

The HAL was unable to read the revision code register on the S1D13705. Ensure that the S1D13705 hardware is installed and that the hardware platform has been configured correctly. Also check that the display memory address has been configured correctly.

ERROR: Unable to locate/load S1D13XXX.VXD

1375PLAY was unable to load a required driver. The file S1D13XXX.VXD should be located in x:\WINDOWS\SYSTEM or in x:\WINNT\SYSTEM. If the file is not there, install it as described in the “*S1D13XXX 32-Bit Windows Device Driver Installation Guide*”, document number X00A-E-003-xx.

ERROR: An IOCTL error occurred

This message indicates an error at the IO control layer occurred. The usual cause for this is an incorrect hardware configuration.

ERROR: The HAL returned an unknown error

This message should never be displayed, it indicates that 1375PLAY is unable to determine the cause of an error returned from the HAL.

6 1375BMP DEMONSTRATION PROGRAM

6.1 1375BMP

1375BMP is a demonstration program for the S1D13705 which can read and display .BMP format (Windows bitmap) files.

The 1375BMP display utility is designed to operate on an x86 based personal computer. There are both 16-bit and 32-bit versions of 1375BMP. The 16-bit version is for use under DOS when the S1D13705 evaluation board has been configured for D0000. The 32-bit version is intended for use under Win32. Before use 1375BMP must be configured for the display system. Consult documentation for the program 1375CFG.EXE which can be used to configure 1375BMP.

1375BMP is not supported on non-PC platforms.

Installation

For 16-Bit Program Version: copy the file 1375BMPEXE to a directory that is in the DOS path on your hard drive.

For 32-Bit Program Version: install the 32-bit Windows device driver S1D13XXX.VXD as described in the “*S1D13XXX 32-Bit Windows Device Driver Installation Guide*”, document number X00A-E-003-xx. Copy the file 1375BMPEXE to a directory that is in the DOS path on your hard drive.

Usage

At the prompt, type:

```
1375bmp bmp_file [/a[time]] [/l] [/p] [/noinit] [/?].
```

Where:	bmp_file	the name of the file to display
	/a[time]	automatic mode returns to the operating system after “time” seconds. If time is not specified the default is 5 seconds. This option is intended for use with batch files to automate displaying a series of images.
	/l	override default configuration settings and set landscape display mode.
	/p	override default configuration settings and set portrait display mode.
	/noinit	bypass the register initialization and use the current setup use this option to override changes that take place to the timing registers
	/?	displays the Help screen

Comments

- 1375BMP currently views only Windows BMP format images.

Program Messages

ERROR: Did not find an S1D13705 device.

The HAL was unable to locate an S1D13705 at the configured address. Check that the correct physical address was configured into 1375BMP.EXE

ERROR: Unable to locate/load S1D13XXX.VXD

The file S1D13XXX.VXD is required by the 32-bit version of the 1375BMP. Check that the .VXD file is in c:\WINDOWS\SYSTEM. If the file is not there, install it as described in the “*S1D13XXX 32-Bit Windows Device Driver Installation Guide*”, document number X00A-E-003-xx.

ERROR: An IOCTL error occurred.

The device driver S1D13XXX.VXD was unable to assign memory. Check that the PC hardware is configured correctly and that 1375BMP has been configured with the correct memory location.

ERROR: The HAL returned an unknown error.

This error message should never be seen. Contact ERD.

ERROR: Could not initialize device.

The HAL failed to initialize the S1D13705.

Failed to open .BMP file '?.....?'

1375BMP was unable to open the .BMP file ?.....? specified on the command line.

?.....? is not a valid bitmap file.

While performing validity checks it was determined that the file ?.....? is either not a valid .BMP file or is of an unsupported format.

ERROR: Unable to set a suitable display mode.

1375BMP was unable to set a display mode to view the image with.

ERROR: Currently unable to process images greater than 8 bpp.

1375BMP can decode images of 8BPP or less color depth. Try reducing the color depth of your image.

ERROR: Image larger than display memory size.

The amount of memory required by this image is more than the amount of memory available to the S1D13705. Try choosing a smaller image.

ERROR: Unable to allocate enough memory to decode the image.

In order to decode a .BMP image 1375BMP needs to allocate some additional system memory. This message is seen if the call to allocate additional memory fails.

7 1375PWR POWER SAVE UTILITY

7.1 1375PWR

The 1375PWR Power Save Utility is a tool to assist in the testing of the software and hardware power save modes.

Refer to the section titled “Power Save Modes” in the “*S1D13705 Programming Notes and Examples*” manual, document number X26A-G-002-01, and the “*S1D13705 Functional Hardware Specification*”, document number X26A-A-001-02 for further information.

The 1375PWR utility must be configured and/or compiled to work with your hardware platform. Consult documentation for the program 1375CFG.EXE which can be used to configure 1375PWR.

This software is designed to work in both embedded and personal computer (PC) environments. For the embedded environment, it is assumed that the system has a means of downloading software from the PC to the target platform. Typically this is done by serial communications, where the PC uses a terminal program to send control commands and information to the target processor. Alternatively, the PC can program an EPROM, which is then placed in the target platform. Some target platforms can also communicate with the PC via a parallel port connection, or an Ethernet connection.

S1D13705 Supported Evaluation Platforms

1375PWR has been designed to work with the following S1D13705 supported evaluation platforms:

- PC system with an x86 processor. Both 16-bit and 32-bit code is supported.
- M68EC000IDP (Integrated Development Platform) board, revision 3.0, with a Motorola M68EC000 processor.
- SH3-LCEVB board, revision B, with an Hitachi SH-3 HD6417780 processor.

If the platform you are using is different from the above, please see the S1D13705 “*Programming Notes and Examples*” manual, document number X26A-G-002-01.

Installation

PC Platform

For 16-Bit Program Version: copy the file 1375PWR.EXE to a directory that is in the DOS path on your hard drive.

For 32-Bit Program Version: install the 32-bit Windows device driver S1D13XXX.VXD as described in the “*S1D13XXX 32-Bit Windows Device Driver Installation Guide*”, document number X00A-E-003-xx. Copy the file 1375PWR.EXE to a directory that is in the DOS path on your hard drive.

Embedded Platform

Download the program 1375PWR to the system.

Usage

PC platform: at the prompt, type `1375pwr [s0] [s1] [h0] [h1]`.

Embedded platform: execute `1375pwr` and at the prompt, type the command line argument.

Where :	s0	resets software power save mode
	s1	sets software power save mode
	h0	resets (disables) hardware power save mode (REG[03h] bit 2)
	h1	sets (enables) hardware power save mode (REG[03h] bit 2)
	/?	displays this usage message

Program Messages

ERROR: Did not find a 13705 device.

The HAL was unable to read the revision code register on the S1D13705. Ensure that the S1D13705 hardware is installed and that the hardware platform has been configured correctly. Also check that the display memory address has been configured correctly.

ERROR: Unable to locate/load S1D13XXX.VXD

1375PLAY was unable to load a required driver. The file S1D13XXX.VXD should be located in `x:\WINDOWS\SYSTEM` or in `x:\WINNT\SYSTEM`. If the file is not there, install it as described in the S1D13XXX 32-Bit Windows Device Driver Installation Guide, document number X00A-E-003-xx.

ERROR: An IOCTL error occurred

This message indicates an error at the IO control layer occurred. The usual cause for this is an incorrect hardware configuration.

ERROR: The HAL returned an unknown error

This message should never be displayed, it indicates that 1375SHOW is unable to determine the cause of an error returned from the HAL.

Software Power Save Mode set.

This message is a confirmation that the register setting to enable software power save mode has been set.

Software Power Save Mode reset.

This message is a confirmation that the register setting to disable software power save mode has been set.

Hardware Power Save Mode is now Enabled.

This message confirms that hardware initiated power save mode has been enabled. The S1D13705 will enter a hardware power save mode upon application of the appropriate logic level to the hardware power save mode input pin.

Hardware Power Save Mode is now Disabled.

This message confirms that the register setting to disable hardware initiated power save mode has been set. In this state the S1D13705 should ignore the state of the hardware power save mode input pin.

THIS PAGE IS BLANK.

S1D13705F00A
Embedded Memory LCD Controller

S5U13705B00C Rev.1.0
ISA Bus
Evaluation Board
User's Manual

1	INTRODUCTION	4-1
1.1	Features	4-1
2	INSTALLATION AND CONFIGURATION.....	4-2
3	LCD INTERFACE PIN MAPPING	4-3
4	CPU/BUS INTERFACE CONNECTOR PINOUTS.....	4-4
5	HOST BUS INTERFACE PIN MAPPING	4-6
6	TECHNICAL DESCRIPTION.....	4-7
6.1	Embedded Memory Support	4-7
6.2	ISA Bus Support	4-8
6.2	Display Adapter Card Support.....	4-8
6.2	Expanded Memory Manager Support.....	4-8
6.3	Non-ISA Bus Support	4-8
6.4	Decoding Logic.....	4-9
6.5	Clock Input Support.....	4-9
6.6	LCD Panel Voltage Setting.....	4-9
6.7	Monochrome LCD Panel Support	4-9
6.8	Color Passive LCD Panel Support	4-9
6.9	Color TFT/D-TFD LCD Panel Support.....	4-10
6.10	Power Save Modes	4-10
6.11	Adjustable LCD Panel Negative Power Supply	4-10
6.12	Adjustable LCD Panel Positive Power Supply	4-10
6.13	CPU/Bus Interface Header Strips.....	4-10
7	PARTS LIST.....	4-11
8	SCHEMATIC DIAGRAMS	4-12

List of Figures

Figure 8-1 S5U13705B00C Schematic Diagram (1 of 4) 4-12
Figure 8-2 S5U13705B00C Schematic Diagram (2 of 4) 4-13
Figure 8-3 S5U13705B00C Schematic Diagram (3 of 4) 4-14
Figure 8-4 S5U13705B00C Schematic Diagram (4 of 4) 4-15

List of Tables

Table 2-1 Configuration DIP Switch Settings 4-2
Table 2-2 Host Bus Selection 4-2
Table 2-3 Jumper Settings 4-2
Table 3-1 LCD Signal Connector (J5) Pinout 4-3
Table 4-1 CPU/BUS Connector (H1) Pinout 4-4
Table 4-2 CPU/BUS Connector (H2) Pinout 4-5
Table 5-1 Host Bus Interface Pin Mapping 4-6

1 INTRODUCTION

This manual describes the setup and operation of the S5U13705B00C Rev. 1.0 Evaluation Board. Implemented using the S1D13705 Embedded Memory Color LCD Controller, the S5U13705B00C board is designed for the 16-bit ISA bus environment. To accommodate other bus architectures, the S5U13705B00C board also provides CPU/Bus interface connectors.

For more information regarding the S1D13705, refer to the “*S1D13705 Hardware Functional Specification*”, document number X27A-A-001-02.

1.1 Features

- 80-pin QFP14 package.
- SMT technology for all appropriate devices.
- 4/8-bit monochrome and color passive LCD panel support.
- 9/12-bit LCD TFT/D-TFD panel support.
- Selectable 3.3V or 5V LCD panel support.
- Oscillator support for CLKI (up to 50MHz with internal clock divider or 25MHz with no internal clock divider).
- Embedded 80K byte SRAM display buffer for 1/2/4 bit-per-pixel (bpp), 2/4/16-level gray shade display and 1/2/4/8 bpp, 2/4/16/256 level color display.
- Support for software and hardware power save modes.
- On-board adjustable LCD bias positive power supply (+23V to +40V).
- On-board adjustable LCD bias negative power supply (-23V to -14V).
- 16-bit ISA bus support.
- CPU/Bus interface header strips for non-ISA bus support.

2 INSTALLATION AND CONFIGURATION

The S1D13705 has four configuration inputs, CNF[3:0], which are read on the rising edge of RESET# and are fully configurable on this evaluation board. One six-position DIP switch is provided on the board to configure the four configuration inputs, select the S5U13705B00C memory/register start address, and enable/disable hardware power save mode.

The following settings are recommended when using the S5U13705B00C with the ISA bus.

Table 2-1 Configuration DIP Switch Settings

Switch	Signal	Closed (0 or low)	Open (1 or high)
S1-1	CNF0	See "Host Bus Selection" table below	See "Host Bus Selection" table below
S1-2	CNF1		
S1-3	CNF2		
S1-4	CNF3	Little Endian	Big Endian
S1-5	ADDR	Memory/Register Start Address = C0000h	Memory/Register Start Address = F0000h
S1-6	GPIO0	Hardware Suspend Disable	Hardware Suspend Enable

= recommended settings (configured for ISA bus support)

Table 2-2 Host Bus Selection

S1-3	S1-2	S1-1	BS#	Host Bus Interface
0	0	0	X	SH-4 bus interface
0	0	1	X	SH-3 bus interface
0	1	0	X	reserved
0	1	1	X	MC68K bus interface #1, 16-bit
1	0	0	X	reserved
1	0	1	X	MC68K bus interface #2, 16-bit
1	1	0	0	reserved
1	1	0	1	reserved
1	1	1	0	Generic #1, 16-bit
1	1	1	1	Generic #2, 16-bit

= recommended settings (configured for ISA bus support)

Table 2-3 Jumper Settings

	Description	1-2	2-3
JP1	IOV _{DD} Selection	5.0V IOV _{DD}	3.3V IOV _{DD}
JP2	BS# Signal Selection	Pulled up to IOV _{DD}	No Connection
JP3	RD/WR# Signal Selection	Pulled up to IOV _{DD}	No Connection
JP4	LCD Panel Voltage Selection	5V LCD Panel	3.3V LCD Panel
JP5	LCDPWR polarity	Active low ('LCDPWR#')	Active high ('LCDPWR')

= recommended settings (JP1 through JP3 configured for ISA bus support)

3 LCD INTERFACE PIN MAPPING

Table 3-1 LCD Signal Connector (J5) Pinout

Connector		Single Passive Panel					Dual Passive Panel		Color TFT/D-TFD	
Pin Name	Pin #	Color			Mono		Color	Mono	9-bit	12-bit
		4-bit	8-bit	8-bit Alternate Format	4-bit	8-bit	8-bit	8-bit		
BFPDAT0	1	driven 0	D0	LD0	driven 0	D0	D0	LD0	R2	R3
BFPDAT1	3	driven 0	D1	LD1	driven 0	D1	D1	LD1	R1	R2
BFPDAT2	5	driven 0	D2	LD2	driven 0	D2	D2	LD2	R0	R1
BFPDAT3	7	driven 0	D3	LD3	driven 0	D3	D3	LD3	G2	G3
BFPDAT4	9	D0	D4	UD0	D0	D4	D4	UD0	G1	G2
BFPDAT5	11	D1	D5	UD1	D1	D5	D5	UD1	G0	G1
BFPDAT6	13	D2	D6	UD2	D2	D6	D6	UD2	B2	B3
BFPDAT7	15	D3	D7	UD3	D3	D7	D7	UD3	B1	B2
BFPDAT8	17	GPIO1	GPIO1	GPIO1	GPIO1	GPIO1	GPIO1	GPIO1	B0	B1
BFPDAT9	19	GPIO2	GPIO2	GPIO2	GPIO2	GPIO2	GPIO2	GPIO2	GPIO2	R0
BFPDAT10	21	GPIO3	GPIO3	GPIO3	GPIO3	GPIO3	GPIO3	GPIO3	GPIO3	G0
BFPDAT11	23	GPIO4/ Inverse Video	GPIO4/ Inverse Video	GPIO4/ Inverse Video	GPIO4/ Inverse Video	GPIO4/ Inverse Video	GPIO4/ Inverse Video	GPIO4/ Inverse Video	GPIO4	B0
BFPSHIFT	33	FPSHIFT	FPSHIFT	FPSHIFT	FPSHIFT	FPSHIFT	FPSHIFT	FPSHIFT	FPSHIFT	FPSHIFT
BFPSHIFT2	35		FPSHIFT2							
BFPLINE	37	FPLINE	FPLINE	FPLINE	FPLINE	FPLINE	FPLINE	FPLINE	FPLINE	FPLINE
BFP-FRAME	39	FPFRAM E	FPFRAM E	FPFRAM E	FPFRAM E	FPFRAM E	FPFRAM E	FPFRAM E	FPFRAM E	FPFRAM E
GND	2-26 (Even Pins)	GND	GND	GND	GND	GND	GND	GND	GND	GND
N / C	28									
VLCD	30	LCD panel negative bias voltage (-24V to -14V)								
LCDV _{CC}	32	+3.3V or +5V (selectable with JP4)								
+12V	34	+12V	+12V	+12V	+12V	+12V	+12V	+12V	+12V	+12V
VDDH	36	LCD panel positive bias voltage (+23V to +40V)								
BDRDY	38	MOD		MOD	MOD	MOD	MOD	MOD	DRDY	DRDY
BLCDPWR	40	LCDPWR	LCDPWR	LCDPWR	LCDPWR	LCDPWR	LCDPWR	LCDPWR	LCDPWR	LCDPWR

- Note:** 1.Un-used GPIO pins must be connected to IO V_{DD}.
2.Inverse Video is enabled on FPDAT11 by REG[02h] bit 1.

4 CPU/BUS INTERFACE CONNECTOR PINOUTS

Table 4-1 CPU/BUS Connector (H1) Pinout

Connector Pin No.	CPU/BUS Pin Name	Comments
1	SD0	Connected to DB0 of the S1D13705
2	SD1	Connected to DB1 of the S1D13705
3	SD2	Connected to DB2 of the S1D13705
4	SD3	Connected to DB3 of the S1D13705
5	GND	Ground
6	GND	Ground
7	SD4	Connected to DB4 of the S1D13705
8	SD5	Connected to DB5 of the S1D13705
9	SD6	Connected to DB6 of the S1D13705
10	SD7	Connected to DB7 of the S1D13705
11	GND	Ground
12	GND	Ground
13	SD8	Connected to DB8 of the S1D13705
14	SD9	Connected to DB9 of the S1D13705
15	SD10	Connected to DB10 of the S1D13705
16	SD11	Connected to DB11 of the S1D13705
17	GND	Ground
18	GND	Ground
19	SD12	Connected to DB12 of the S1D13705
20	SD13	Connected to DB13 of the S1D13705
21	SD14	Connected to DB14 of the S1D13705
22	SD15	Connected to DB15 of the S1D13705
23	RESET#	Connected to the RESET# signal of the S1D13705
24	GND	Ground
25	GND	Ground
26	GND	Ground
27	+12V	12 volt supply
28	+12V	12 volt supply
29	WE0#	Connected to the WE0# signal of the S1D13705
30	WAIT#	Connected to the WAIT# signal of the S1D13705
31	CS#	Connected to the CS# signal of the S1D13705
32	NC	Not connected
33	WE1#	Connected to the WE1# signal of the S1D13705
34	IOV _{DD}	Connected to the IOV _{DD} supply of the S1D13705

Table 4-2 CPU/BUS Connector (H2) Pinout

Connector Pin No.	CPU/BUS Pin Name	Comments
1	SA0	Connected to AB0 of the S1D13705
2	SA1	Connected to AB1 of the S1D13705
3	SA2	Connected to AB2 of the S1D13705
4	SA3	Connected to AB3 of the S1D13705
5	SA4	Connected to AB4 of the S1D13705
6	SA5	Connected to AB5 of the S1D13705
7	SA6	Connected to AB6 of the S1D13705
8	SA7	Connected to AB7 of the S1D13705
9	GND	Ground
10	GND	Ground
11	SA8	Connected to AB8 of the S1D13705
12	SA9	Connected to AB9 of the S1D13705
13	SA10	Connected to AB10 of the S1D13705
14	SA11	Connected to AB11 of the S1D13705
15	SA12	Connected to AB12 of the S1D13705
16	SA13	Connected to AB13 of the S1D13705
17	GND	Ground
18	GND	Ground
19	SA14	Connected to AB14 of the S1D13705
20	SA15	Connected to AB15 of the S1D13705
21	SA16	Connected to AB16 of the S1D13705
22	SA17	Connected to SA17 of the ISA bus connector
23	SA18	Connected to SA18 of the ISA bus connector
24	SA19	Connected to SA19 of the ISA bus connector
25	GND	Ground
26	GND	Ground
27	V _{CC}	5 volt supply
28	V _{CC}	5 volt supply
29	RD/WR#	Connected to the R/W# signal of the S1D13705
30	BS#	Connected to the BS# signal of the S1D13705
31	BUSCLK	Connected to the BCLK signal of the S1D13705
32	RD#	Connected to the RD# signal of the S1D13705
33	NC	Not connected
34	CLKI	Connected to the CLKI signal of the S1D13705

5 *HOST BUS INTERFACE PIN MAPPING*

Table 5-1 Host Bus Interface Pin Mapping

S1D13705 Pin Names	SH-3	SH-4	MC68K #1	MC68K #2	Generic Bus #1	Generic Bus #2
AB[16:1]	A[16:1]	A[16:1]	A[16:1]	A[16:1]	A[16:1]	A[16:1]
AB0	A0	A0	LDS#	A0	A0	A0
DB[15:0]	D[15:0]	D[15:0]	D[15:0]	D[15:0]	D[15:0]	D[15:0]
WE1#	WE1#	WE1#	UDS#	DS#	WE1#	BHE#
CS#	CSn#	CSn#	External Decode	External Decode	External Decode	External Decode
BCLK	CKIO	CKIO	BCLK	BCLK	BCLK	BCLK
BS#	BS#	BS#	AS#	AS#	Connect to V _{SS}	Connect to IO V _{DD}
RD/WR#	RD/WR#	RD/WR#	R/W#	R/W#	RD1#	Connect to IO V _{DD}
RD#	RD#	RD#	Connect to IO V _{DD}	SIZ1	RD0#	RD#
WE0#	WE0#	WE0#	Connect to IO V _{DD}	SIZ0	WE0#	WE#
WAIT#	WAIT#	RDY#	DTACK#	DSACK1#	WAIT#	WAIT#
RESET#	RESET#	RESET#	RESET#	RESET#	RESET#	RESET#

6 TECHNICAL DESCRIPTION

6.1 Embedded Memory Support

The S1D13705 contains 80K bytes of embedded, 16-bit, SRAM used for the display buffer and a 32 byte internal register set.

Since the S1D13705 does not distinguish between memory and register accesses, both the 80K byte display buffer and the 32 byte register set must be memory mapped into the host's memory space.

When using the S5U13705B00C board on an ISA bus system, the board can be configured to map the S1D13705 to one of two memory blocks.

The SRAM start address is determined by a DIP switch setting. See "Table 2-1 Configuration DIP Switch Settings," on page 4-2.

1. When switch S1-5 is in the closed position, the S1D13705 is mapped into segments 0C0000h and 0D0000h.

This memory space is in the first 1M byte of ISA bus memory and should be used if these segments are not taken up by other devices such as network adapters, SCSI cards, or other peripherals.

Note: Since VGA and VGA compatible video adapters use address 0C8000, these cards cannot be used while using the S5U13705B00C board at this memory address. A monochrome display adapter, a terminal, or a non-VGA compatible display adapter must be used.

2. When switch S1-5 is in the open position, the S1D13705 is mapped into the upper megabyte of ISA bus memory, starting address of F00000h. To use this memory on an ISA bus system, the system BIOS has to be configured to set a memory 'hole' starting at this address. Some systems allow the user to configure the size of this hole and the starting address of where it begins while others just allow a 1M byte hole at the top of the 16M byte memory space. This memory hole is configured by entering the system CMOS Setup Utility. This memory space should be used if segments 0Dh and 0Eh are being used by other devices or if a VGA display adapter is needed.

Starting at the SRAM start address, the board design decodes a 128K byte segment accommodating both the 80K byte display buffer and the S1D13705 internal register set. The S1D13705 registers are mapped into the upper 32 bytes of the 128K byte segment (1FFE0h to 1FFFFh).

When using the S5U13705B00C board on a non-ISA bus system, system or external decode logic must map the S1D13705 into an appropriate memory space.

6.2 *ISA Bus Support*

The S5U13705B00C board has been designed to directly support the 16-bit ISA bus environment and can be used in conjunction with either a VGA or a monochrome display adapter card.

There are 4 configuration inputs associated with the Host Interface (CNF[2:0] and BS#). Refer to “Table 2-3 Jumper Settings,” on page 4-2 and “Table 5-1 Host Bus Interface Pin Mapping,” on page 4-6 for complete details.

Display Adapter Card Support

When using the S5U13705B00C in conjunction with another primary Display Adapter (VGA or Monochrome) the following applies:

VGA Display Adapter

All VGA display adapters can be used with the S5U13705B00C board if the S1D13705 is mapped to the upper 1M Byte of ISA bus memory, address F00000-F1FFFF. If the S1D13705 is mapped to the address range 0C0000-0D0000, then no VGA or VGA compatible display adapters can be used with the S5U13705B00C board. See “6.1 Embedded Memory Support” on page 4-7.

Monochrome Display Adapter

The S5U13705B00C board can be used with monochrome display adapters at both memory addresses.

Expanded Memory Manager Support

If a memory manager is being used for system memory, the address range selected for the SRAM start address must be excluded from use or memory conflicts will arise.

6.3 *Non-ISA Bus Support*

The S5U13705B00C board is specifically designed to support the standard 16-bit ISA bus. However, the S1D13705 directly supports many other host bus interfaces. Header strips H1 and H2 are provided and contain all the necessary IO pins to interface to these host buses. See “4 CPU/Bus Interface Connector Pinouts” on page 4-4; “Table 2-1 Configuration DIP Switch Settings,” on page 4-2; and “Table 2-3 Jumper Settings,” on page 4-2 for details.

When using the header strips to provide the bus interface observe the following:

- All signals on the ISA bus card edge must be isolated from the ISA bus (do not plug the card into a computer). Power must be provided through the headers.
- U7, a PLD of type 22V10-15, is used to provide the S1D13705 CS# (pin 74) and other decoding logic signals for ISA bus mode. For non-ISA applications, this functionality must be provided externally. Remove the PAL from its socket to eliminate conflicts driving S1D13705 control signals. Refer to Table 5-1 for connection details.

Note: When using a 3.3V host bus interface, IO V_{DD} must be set to 3.3V by setting jumper (JP1) to the 2-3 position. Refer to “Table 2-3 Jumper Settings,” on page 4-2.

6.4 Decoding Logic

All the required decode logic is provided through a PLD of type 22V10-15 (U7, socketed). This PAL contains the following equations.

```
!CS      = (Address >= ^hC0000) & (Address <= ^hDFFFF) & !ADDR & REFRESH & ENAB
          # (Address1 >= ^hF00000) & (Address1 <= ^hF1FFFF) & ADDR & REFRESH & ENAB;

!MEMCS16 = (Address1 >= ^h0C0000) & (Address1 <= ^h0DFFFF) & !ADDR & !CS
          # (Address1 >= ^hF00000) & (Address1 <= ^hF1FFFF) & ADDR & !CS;

!WE0     = (!CS & !ADDR & !SMEMW) # (!CS & ADDR & !MEMW);

!RD      = (!CS & !ADDR & !SMEMR) # (!CS & ADDR & !MEMR);
```

Note:ADDR = Switch S1-5 (see Table 2-1, “Configuration DIP Switch Settings,” on page 1-2).

6.5 Clock Input Support

The input clock (CLKI) frequency can be up to 50MHz for the S1D13705 if the internal clock divide-by-2 mode is set. If the clock divider is not used, the maximum CLKI frequency is 25MHz. There is no minimum input clock frequency.

A 25.0MHz oscillator (U2, socketed) is provided as the input clock source. However, depending on the LCD resolution, desired frame rate, and power consumption budget, a lower frequency clock may be required.

6.6 LCD Panel Voltage Setting

The S5U13705B00C board supports both 3.3V and 5V LCD panels through the LCD connector J5. The voltage level is selected by setting jumper J4 to the appropriate position. Refer to “Table 2-3 Jumper Settings,” on page 4-2 for setting this jumper.

Although not necessary for signal buffering, buffers have been implemented in the board design to provide flexibility in handling 3 and 5 volt panels.

6.7 Monochrome LCD Panel Support

The S1D13705 directly supports 4 and 8-bit, dual and single, monochrome passive LCD panels. All necessary signals are provided on the 40-pin ribbon cable header J5. The interface signals on the cable are alternated with grounds to reduce crosstalk and noise.

Refer to “Table 3-1 LCD Signal Connector (J5) Pinout,” on page 4-3 for specific connection information.

6.8 Color Passive LCD Panel Support

The S1D13705 directly supports 4 and 8-bit, dual and single, color passive LCD panels. All the necessary signals are provided on the 40-pin ribbon cable header J5. The interface signals on the cable are alternated with grounds to reduce crosstalk and noise.

Refer to “Table 3-1 LCD Signal Connector (J5) Pinout,” on page 4-3 for specific connection information.

6.9 Color TFT/D-TFD LCD Panel Support

The S1D13705 directly supports 9 and 12-bit active matrix color TFT/D-TFD panels. All the necessary signals can also be found on the 40-pin LCD connector J5. The interface signals on the cable are alternated with grounds to reduce crosstalk and noise.

Refer to “Table 3-1 LCD Signal Connector (J5) Pinout,” on page 4-3 for connection information.

6.10 Power Save Modes

The S1D13705 supports hardware and software power save modes. These modes are controlled by the utility 1375PWR. The hardware power save mode needs to be enabled by 1375PWR and then activated by DIP switch S1-6. See “Table 2-1 Configuration DIP Switch Settings,” on page 4-2 for details on setting this switch.

6.11 Adjustable LCD Panel Negative Power Supply

For those LCD panels requiring a negative power supply to provide between -23V and -14V ($I_{out}=25mA$) a power supply has been provided as an integral part of this design. The VLCD power supply can be adjusted by R21 to give an output voltage from -23V to -14V, and is enabled and disabled by the active high S1D13705 control signal LCDPWR, inverted externally.

Determine the panel’s specific power requirements and set the potentiometer accordingly before connecting the panel.

6.12 Adjustable LCD Panel Positive Power Supply

For those LCD panels requiring a positive power supply to provide between +23V and +40V ($I_{out}=45mA$) a power supply has been provided as an integral part of this design. The VDDH power supply can be adjusted by R15 to provide an output voltage from +23V to +40V and is enabled and disabled by the active high S1D13705 control signal LCDPWR, inverted externally.

Determine the panel’s specific power requirements and set the potentiometer accordingly before connecting the panel.

6.13 CPU/Bus Interface Header Strips

All of the CPU/Bus interface pins of the S1D13705 are connected to the header strips H1 and H2 for easy interface to a CPU/Bus other than ISA.

Refer to “Table 4-1 CPU/BUS Connector (H1) Pinout,” on page 4-4 and “Table 4-2 CPU/BUS Connector (H2) Pinout,” on page 4-5 for specific settings.

Note: These headers only provide the CPU/bus interface signals from the S1D13705. When another host bus interface is selected by CNF[3:0] and BS#, appropriate external decoding logic **MUST** be used to access the S1D13705. Refer to “Table 5-1 Host Bus Interface Pin Mapping,” on page 4-6 for connection details.

7 PARTS LIST

Item #	Qty/board	Designation	Part Value	Description
1	15	C1-C11, C15-17,C24	0.1uF, 20%, 50V	0805 ceramic capacitor
2	3	C12-14	10uF, 10%, 25V	Tantalum capacitor size D
3	2	C18, C22	47uF, 10%, 16V	Tantalum capacitor size D
4	3	C19-C21	4.7uF, 10%, 50V	Tantalum capacitor size D
5	1	C23	56uF, 20%, 63V	Electrolytic, radial, low ESR
6	2	H1,H2	CON34A Header	0.1" 17x2 header, PTH
7	5	JP1-JP4, JP6	HEADER 3	0.1" 1x3 header, PTH
8	1	J1	AT CON-A	ISA Bus gold fingers
9	1	J2	AT CON-B	ISA Bus gold fingers
10	1	J3	AT CON-C	ISA Bus gold fingers
11	1	J4	AT CON-D	ISA Bus gold fingers
12	1	J5	CON40A	Shrouded header 2x20, PTH, center key
13	1	L1	1uH	MCI-1812 inductor
14	2	L3, L4	Ferrite bead	Philips BDS3/3/8.9-4S2
15	1	Q1	2N3906	PNP signal transistor, SOT23
16	1	Q2	2N3904	NPN signal transistor, SOT23
17	6	R1-R6	15K, 5%	0805 resistor
18	9	R7-R13, R17, R18	10K, 5%	0805 resistor
19	1	R14	475K, 1%	0805 resistor
20	1	R15	200K Pot.	200K Trim POT Spectrol 63S204T607 (or equivalent)
21	1	R16	14K, 1%	0805 resistor
22	3	R19, R20, R22	100K, 5%	0805 resistor
23	1	R21	100K Pot.	100K Trim POT Spectrol 63S104T607 (or equivalent)
24	1	S1	SW DIP-6	6 position DIP switch
25	1	U1	S1D13705F00A	QFP14-80, 80 pin, SMT
26	1	U2	25.0 MHz oscillator	FOX 25MHz oscillator or equiv., 14 pin DIP socketed
27	3	U3-U5	74AHC244	SO-22, TI74AHC244
28	1	U6	LT1117CM-3.3	Linear Technology 5V to 3.3V regulator, 800mA
29	1	U7	PLD22V10-15	PLD type 22V10-15, 20 Pin DIP, socketed
30	1	U8	74ALS125	SO-14, 74ALS125
31	1	U9	74HCT04	SO-14, 74HCT04
32	1	U10	RD-0412	Xentek RD-0412, positive PS
33	1	U11	EPN001	Xentek EPN001 negative PS

8 SCHEMATIC DIAGRAMS

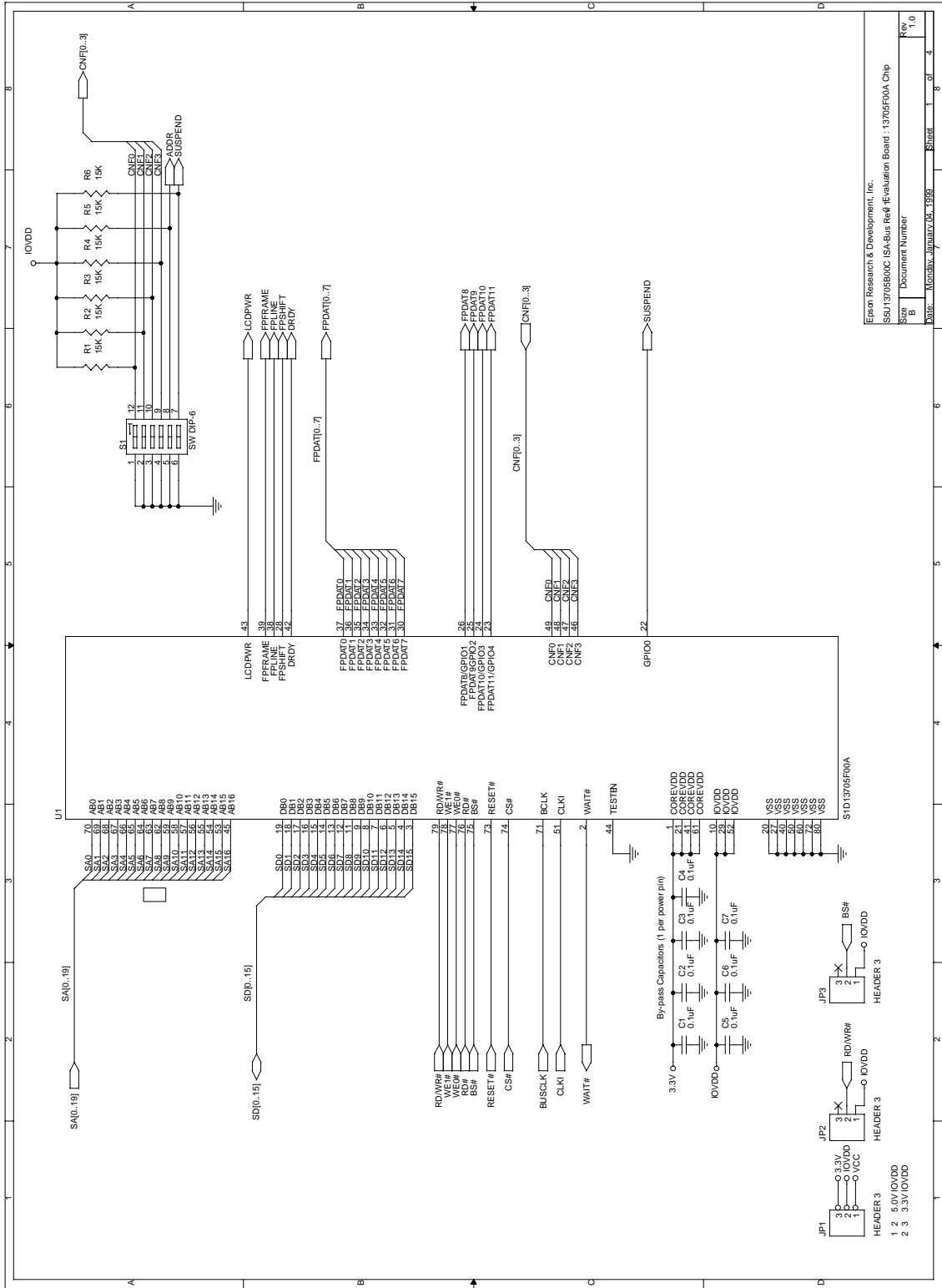

Esron Research & Development, Inc.
 S5U13705B00C ISA-Bus Rev. 1.0 Evaluation Board : 13705FR00A Chip
 Step B Document Number
 Date: 10/20/98 Rev: 1.0

Figure 8-1 S5U13705B00C Schematic Diagram (1 of 4)

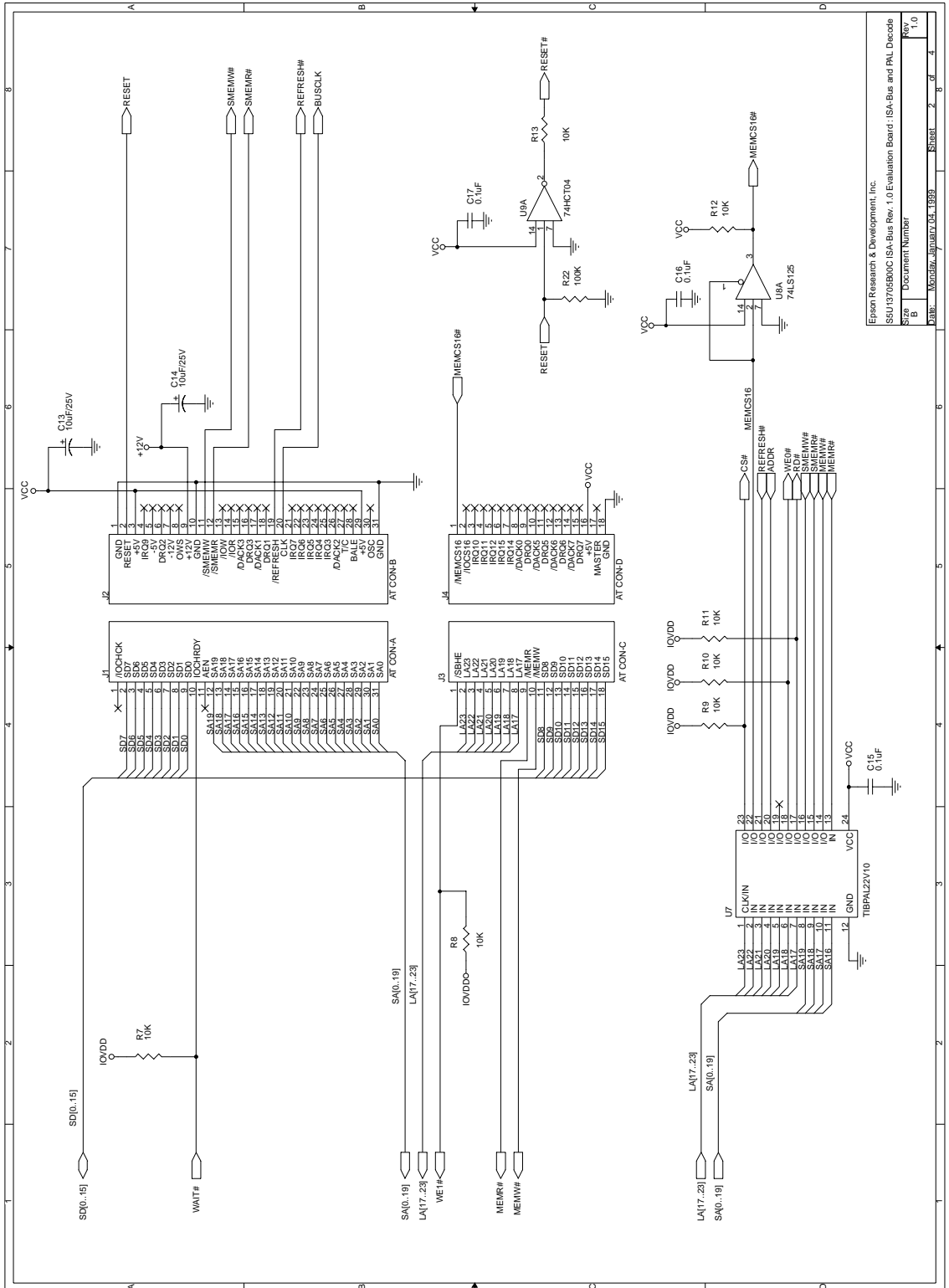
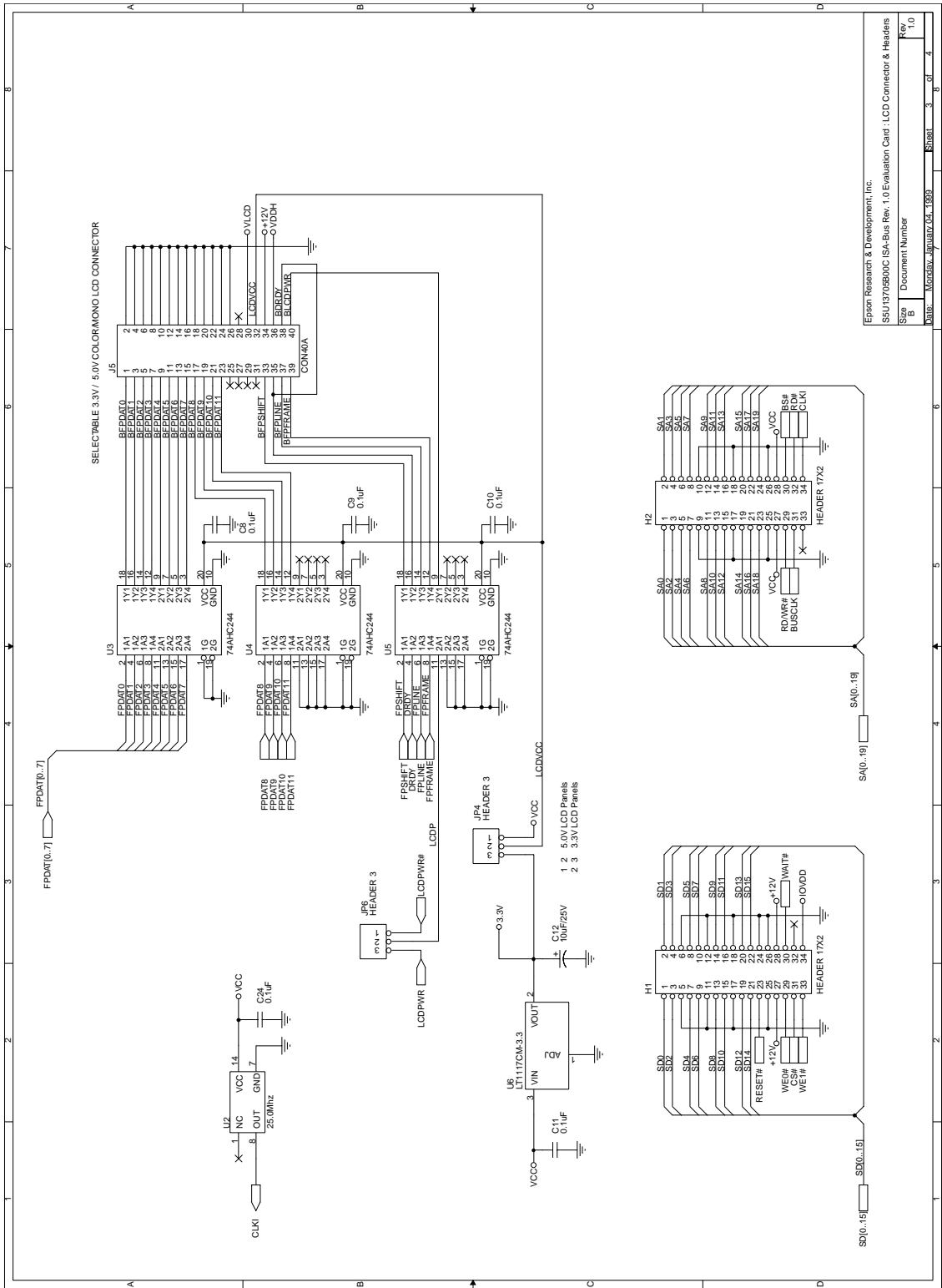

Figure 8-2 S5U13705B00C Schematic Diagram (2 of 4)

Epson Research & Development, Inc.	
S5U13705B00C ISA-Bus Rev. 1.0 Evaluation Board: ISA-Bus and PAL Decode	
S5U13705B00C	Document Number
Rev. 1.0	Date: Monday, January 04, 1999
Sheet 2	of 4



Epson Research & Development, Inc.			
S5U13705B00C ISA-Bus Rev. 1.0 Evaluation Card : LCD Connector & Headers			
Size	Document Number	Revision	Rev
B	MOCEBX-14042Z-04_1999	3	1.0
DATE	NOV 04 1999	3	1.0

Figure 8-3 S5U13705B00C Schematic Diagram (3 of 4)

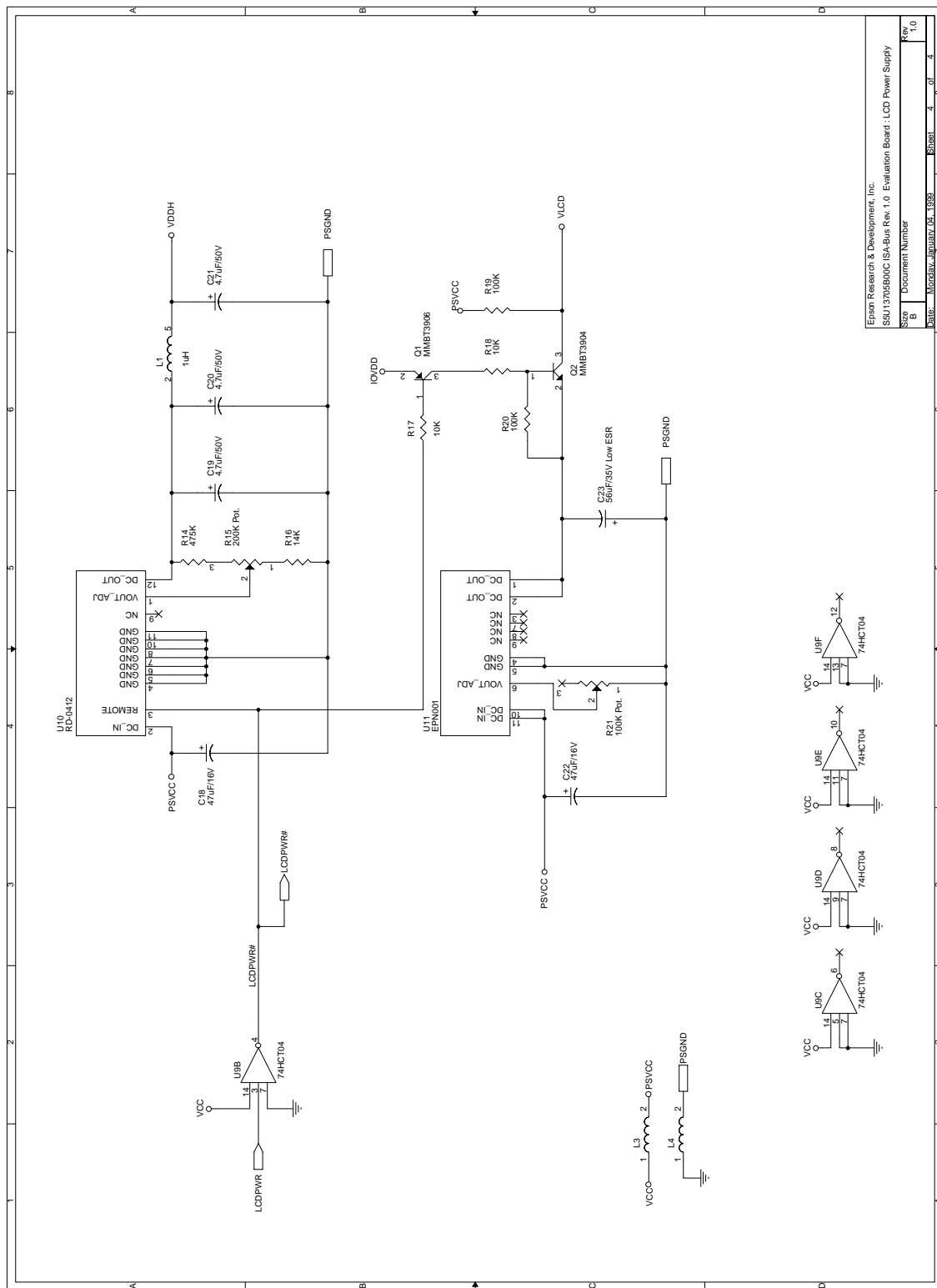

Epson Research & Development, Inc.			
S5U13705B00C ISA-Bus Rev. 1.0 Evaluation Board : LCD Power Supply			
Size	Document Number	Sheet	of
B		3	4
Rev			
B			
1.0			

Figure 8-4 S5U13705B00C Schematic Diagram (4 of 4)

THIS PAGE IS BLANK.

S1D13705F00A
Embedded Memory LCD Controller
Application Notes

1	INTERFACING TO THE MOTOROLA MC68328 “DRAGONBALL” MICROPROCESSOR.....	5-1
1.1	Introduction.....	5-1
1.2	Interfacing to the MC68328.....	5-1
	The MC68328 System Bus.....	5-1
	Chip-Select Module.....	5-2
1.3	S1D13705 Host Bus Interface.....	5-2
	Host Bus Pin Connection.....	5-2
	Generic #1 Interface Mode.....	5-3
	MC68K #1 Interface Mode.....	5-4
1.4	MC68328 To S1D13705 Interface.....	5-5
	Hardware Description.....	5-5
	S1D13705 Hardware Configuration.....	5-7
	MC68328 Chip Select Configuration.....	5-7
1.5	Software.....	5-7
2	INTERFACING TO THE MOTOROLA MPC821 MICROPROCESSOR.....	5-8
2.1	Introduction.....	5-8
2.2	Interfacing to the MPC821.....	5-8
	The MPC8xx System Bus.....	5-8
	MPC821 Bus Overview.....	5-8
	Memory Controller Module.....	5-11
2.3	S1D13705 Host Bus Interface.....	5-11
	Host Bus Interface Modes.....	5-12
	Generic #1 Host Bus Interface Mode.....	5-12
2.4	MPC821 to S1D13705 Interface.....	5-13
	Hardware Description.....	5-13
	MPC821ADS Evaluation Board Hardware Connections.....	5-14
	S1D13705 Hardware Configuration.....	5-15
	MPC821 Chip Select Configuration.....	5-16
	Test Software.....	5-17
2.5	Software.....	5-17
3	INTERFACING TO THE MOTOROLA MCF5307 “COLD FIRE” MICROPROCESSOR.....	5-18
3.1	Introduction.....	5-18
3.2	Interfacing to the MCF5307.....	5-18
	The MCF5307 System Bus.....	5-18
	Chip-Select Module.....	5-20
3.3	S1D13705 Bus Interface.....	5-20
	Host Bus Pin Connection.....	5-20
	Generic #1 Interface Mode.....	5-21
3.4	MCF5307 To S1D13705 Interface.....	5-21
	Hardware Description.....	5-21
	S1D13705 Hardware Configuration.....	5-22
	MCF5307 Chip Select Configuration.....	5-23
3.5	Software.....	5-23
4	INTERFACING TO THE PC CARD BUS.....	5-24
4.1	Introduction.....	5-24
4.2	Interfacing to the PC Card Bus.....	5-24
	The PC Card System Bus.....	5-24
4.3	S1D13705 Bus Interface.....	5-26
	Host Bus Pin Connection.....	5-26
	Generic #2 Interface Mode.....	5-26
4.4	PC Card to S1D13705 Interface.....	5-27
	Hardware Connections.....	5-27
	S1D13705 Hardware Configuration.....	5-28
	Register/Memory Mapping.....	5-28

4.5	Software	5-28
5	INTERFACING TO THE TOSHIBA MIPS TMPR3912 MICROPROCESSOR.....	5-29
5.1	Introduction	5-29
5.2	Interfacing to the TMPR3912	5-29
5.3	S1D13705 Host Bus Interface.....	5-29
	Host Bus Pin Connection.....	5-29
	Generic #1 Interface Mode	5-30
	Generic #2 Interface Mode	5-31
5.4	Direct Connection to the Toshiba TMPR3912.....	5-31
	General Description	5-31
	Memory Mapping and Aliasing	5-32
	S1D13705 Configuration	5-33
5.5	Using the ITE IT8368E PC Card Buffer	5-33
	Hardware Description	5-33
	IT8368E Configuration.....	5-34
	Memory Mapping and Aliasing	5-35
	S1D13705 Configuration	5-35
5.6	Software	5-35
6	INTERFACING TO THE PHILIPS MIPS PR31500/PR31700 PROCESSOR.....	5-36
6.1	Introduction	5-36
6.2	Interfacing to the PR31500/PR31700	5-36
6.3	S1D13705 Host Bus Interface.....	5-36
	Host Bus Pin Connection.....	5-37
	Generic #1 Interface Mode	5-37
	Generic #2 Interface Mode	5-38
6.4	Direct Connection to the Philips PR31500/PR31700	5-39
	General Description	5-39
	Memory Mapping and Aliasing	5-40
	S1D13705 Configuration and Pin Mapping	5-40
6.5	Using the ITE IT8368E PC Card Buffer	5-40
	Hardware Description	5-40
	IT8368E Configuration.....	5-42
	Memory Mapping and Aliasing	5-42
	S1D13705 Configuration	5-42
6.6	Software	5-43
7	INTERFACING TO THE NEC VR4102/VR4111 MICROPROCESSOR.....	5-44
7.1	Introduction	5-44
7.2	Interfacing to the NEC VR4102/VR4111	5-44
	The NEC VR4102/VR4111 System Bus.....	5-44
7.3	S1D13705 Host Bus Interface.....	5-46
	Host Bus Pin Connection.....	5-46
	Generic #2 Interface Mode	5-46
7.4	VR4102/VR4111 to S1D13705 Interface	5-47
	Hardware Description	5-47
	S1D13705 Hardware Configuration.....	5-48
	NEC VR4102/VR4111 Configuration.....	5-48
7.5	Software	5-48
8	INTERFACING TO THE NEC VR4181ATM MICROPROCESSOR.....	5-49
8.1	Introduction	5-49
8.2	Interfacing to the NEC VR4181A	5-49
	The NEC VR4181A System Bus	5-49
8.3	S1D13705 Host Bus Interface.....	5-50
	Host Bus Pin Connection.....	5-50
	Generic #2 Interface Mode	5-50
8.4	VR4181A to S1D13705 Interface.....	5-51

Hardware Description	5-51
S1D13705 Hardware Configuration	5-52
NEC VR4181A Configuration.....	5-52
8.5 Software	5-53
9 S1D13705 POWER CONSUMPTION	5-54
9.1 S1D13705 Power Consumption	5-54
Conditions	5-55
9.2 Summary	5-55

List of Figures

Figure 1-1	Typical Implementation of MC68328 to S1D13705 Interface - MC68K #1	5-5
Figure 1-2	Typical Implementation of MC68328 to S1D13705 Interface - Generic #1	5-6
Figure 2-1	Power PC Memory Read Cycle	5-9
Figure 2-2	Power PC Memory Write Cycle.....	5-10
Figure 2-3	Typical Implementation of MPC821 to S1D13705 Interface	5-13
Figure 3-1	MCF5307 Memory Read Cycle.....	5-19
Figure 3-2	MCF5307 Memory Write Cycle	5-19
Figure 3-3	Typical Implementation of MCF5307 to S1D13705 Interface	5-22
Figure 4-1	PC Card Read Cycle.....	5-25
Figure 4-2	PC Card Write Cycle.....	5-25
Figure 4-3	Typical Implementation of PC Card to S1D13705 Interface	5-27
Figure 5-1	S1D13705 to TMPR3912 Direct Connection	5-32
Figure 5-2	S1D13705 to TMPR3912 Connection Using an IT8368E	5-34
Figure 6-1	S1D13705 to PR31500/PR31700 Direct Connection	5-39
Figure 6-2	S1D13705 to PR31500/PR31700 Connection Using an IT8368E	5-41
Figure 7-1	NEC VR4102/VR4111 Read/Write Cycles.....	5-45
Figure 7-2	Typical Implementation of VR4102/VR4111 to S1D13705 Interface	5-47
Figure 8-1	Typical Implementation of VR4181A to S1D13705 Interface.....	5-51

List of Tables

Table 1-1	Host Bus Interface Pin Mapping	5-2
Table 1-2	Summary of Power-On/Reset Options.....	5-7
Table 1-3	Host Bus Interface Selection.....	5-7
Table 2-1	Host Bus Interface Pin Mapping	5-12
Table 2-2	List of Connections from MPC821ADS to S1D13705.....	5-14
Table 2-3	Configuration Settings.....	5-15
Table 2-4	Host Bus Interface Selection.....	5-15
Table 3-1	Host Bus Interface Pin Mapping	5-20
Table 3-2	Summary of Power-On/Reset Options.....	5-22
Table 3-3	Host Bus Interface Selection.....	5-22
Table 4-1	Host Bus Interface Pin Mapping	5-26
Table 4-2	Summary of Power-On/Reset Options.....	5-28
Table 4-3	Host Bus Interface Selection.....	5-28
Table 5-1	Host Bus Interface Pin Mapping	5-29
Table 5-2	S1D13705 Configuration for Direct Connection.....	5-33
Table 5-3	TMPR3912 to PC Card Slots Address Mapping With and Without the IT8368E	5-35
Table 5-4	S1D13705 Configuration Using the IT8368E	5-35
Table 6-1	Host Bus Interface Pin Mapping	5-37
Table 6-2	S1D13705 Configuration for Direct Connection.....	5-40
Table 6-3	PR31500/PR31700 to PC Card Slots Address Mapping With and Without the IT8368E ..	5-42
Table 6-4	S1D13705 Configuration Using the IT8368E	5-42
Table 7-1	Host Bus Interface Pin Mapping	5-46
Table 7-2	Summary of Power-On/Reset Options.....	5-48
Table 7-3	Host Bus Interface Selection.....	5-48
Table 8-1	Host Bus Interface Pin Mapping	5-50
Table 8-2	Summary of Power-On/Reset Options.....	5-52
Table 8-3	Host Bus Interface Selection.....	5-52
Table 9-1	S1D13705 Total Power Consumption.....	5-55

1 INTERFACING TO THE MOTOROLA MC68328 “DRAGONBALL” MICROPROCESSOR

1.1 Introduction

This application note describes the hardware required to interface the S1D13705 Embedded Memory LCD Controller and the Motorola MC68328 “Dragonball” Microprocessor. By implementing an embedded display refresh buffer, the S1D13705 can reduce system power consumption, improve image quality, and increase system performance as compared to the Dragonball’s on-chip LCD controller.

1.2 Interfacing to the MC68328

The MC68328 System Bus

The MC68328 is an integrated controller for handheld products, based upon the MC68EC000 microprocessor core. It implements a 16-bit data bus and a 32-bit address bus. The bus interface consists of all the standard MC68000 bus interface signals, plus some new signals intended to simplify the task of interfacing to typical memory and peripheral devices.

The MC68000 bus control signals are well documented in Motorola’s user manuals, and will not be described here. A brief summary of the new signals appears below:

- Output Enable (OE#) is asserted when a read cycle is in process; it is intended to connect to the output enable control of a typical static RAM, EPROM, or Flash EPROM device.
- Upper Write Enable and Lower Write Enable (UWE#/LWE#) are asserted during memory write cycles for the upper and lower bytes of the 16-bit data bus; they may be directly connected to the write enable inputs of a typical memory device.

The S1D13705 implements the MC68000 bus interface using its MC68K #1 mode, so this mode may be used to connect the MC68328 directly to the S1D13705 with no glue logic. However, several of the MC68000 bus control signals are multiplexed with IO and interrupt signals on the MC68328, and in many applications it may be desirable to make these pins available for these alternate functions. This requirement may be accommodated through the use of the Generic #1 interface mode on the S1D13705.

Chip-Select Module

The MC68328 can generate up to 16 chip select outputs, organized into four groups “A” through “D”.

Each chip select group has a common base address register and address mask register, to set the base address and block size of the entire group. In addition, each chip select within a group has its own address compare and address mask register, to activate the chip select for a subset of the group’s address block. Finally, each chip select may be individually programmed to control an 8 or 16-bit device, and each may be individually programmed to generate from 0 through 6 wait states internally, or allow the memory or peripheral device to terminate the cycle externally through use of the standard MC68000 DTACK# signal.

Groups A and B can have a minimum block size of 64K bytes, so these are typically used to control memory devices. Chip select A0 is active immediately after reset, so it is typically used to control a boot EPROM device. Groups C and D have a minimum block size of 4K bytes, so they are well-suited to controlling peripheral devices. Chip select D3 is associated with the MC68328 on-chip PCMCIA control logic.

1.3 S1D13705 Host Bus Interface

This section is a summary of the host bus interface modes available on the S1D13705 that may be used to interface to the MC68328.

The S1D13705 implements a 16-bit interface to the host microprocessor which may operate in one of several modes compatible with most of the popular embedded microprocessor families. The two interface modes that may be used for the MC68328 are:

- Motorola MC68K #1 (using Upper Data Strobe/Lower Data Strobe).
- Generic #1 (Chip Select, plus individual Read Enable/Write Enable for each byte).

Host Bus Pin Connection

The following table shows the functions of each host bus interface signal.

Table 1-1 Host Bus Interface Pin Mapping

S1D13705 Pin Names	MC68K #1	Generic #1
AB[15:1]	A[15:1]	A[15:1]
AB0	LDS#	A0
DB[15:0]	D[15:0]	D[15:0]
WE1#	UDS#	WE1#
CS#	External Decode	External Decode
BCLK	CLK	BCLK
BS#	AS#	connect to V _{SS}
RD/WR#	R/W#	RD1#
RD#	connect to IO V _{DD}	RD0#
WE0#	connect to IO V _{DD}	WE0#
WAIT#	DTACK#	WAIT#
RESET#	RESET#	RESET#

For details on configuration, refer to the “S1D13705 Hardware Functional Specification”, document number X27A-A-001-01.

Generic #1 Interface Mode

Generic #1 interface mode is the most general and least processor-specific interface mode on the S1D13705. The Generic # 1 interface mode was chosen for this interface due to the simplicity of its timing.

The interface requires the following signals:

- BUSCLK is a clock input which is required by the S1D13705 host interface. It is separate from the input clock (CLKI) and is typically driven by the host CPU system clock.
- The address inputs AB0 through AB16, and the data bus DB0 through DB15, connect directly to the CPU address and data bus, respectively. On 32-bit big endian architectures such as the Power PC, the data bus would connect to the high-order data lines; on little endian hosts, or 16-bit big endian hosts, they would connect to the low-order data lines. The hardware engineer must ensure that CNF3 selects the proper endian mode upon reset.
- Chip Select (CS#) is driven by decoding the high-order address lines to select the proper register and memory address space.
- WE0# and WE1# are write enables for the low-order and high-order bytes, respectively, to be driven low when the host CPU is writing data to the S1D13705. These signals must be generated by external hardware based on the control outputs from the host CPU.
- RD# and RD/WR# are read enables for the low-order and high-order bytes, respectively, to be driven low when the host CPU is reading data from the S1D13705. These signals must be generated by external hardware based on the control outputs from the host CPU.
- WAIT# is a signal output from the S1D13705 that indicates the host CPU must wait until data is ready (read cycle) or accepted (write cycle) on the host bus. Since host CPU accesses to the S1D13705 may occur asynchronously to the display update, it is possible that contention may occur in accessing the S1D13705 internal registers and/or refresh memory. The WAIT# line resolves these contentions by forcing the host to wait until the resource arbitration is complete. This signal is active low and may need to be inverted if the host CPU wait state signal is active high.
- The Bus Status (BS#) signal is not used in the bus interface for Generic #1 mode. However, BS# is used to configure the S1D13705 for Generic #1 mode and should be tied low (connected to GND).

MC68K #1 Interface Mode

The MC68K #1 Interface Mode can be used to interface to the MC68328 microprocessor if the previously mentioned, multiplexed, bus signals will not be used for other purposes.

The interface requires the following signals:

- BUSCLK is a clock input which synchronizes transfers between the host CPU and the S1D13705. It is separate from the input clock (CLKI) and is typically driven by the host CPU system clock.
- The address inputs AB1 through AB16, and the data bus DB0 through DB15, connect directly to the CPU address and data bus, respectively. On 32-bit big endian architectures such as the Power PC, the data bus would connect to the high-order data lines; on little endian hosts, or 16-bit big endian hosts, they would connect to the low-order data lines. The hardware engineer must ensure that CNF3 selects the proper endian mode upon reset.
- Chip Select (CS#) is driven by decoding the high-order address lines to select the proper register and memory address space.
- A0 and WE1# are the enables for the low-order and high-order bytes, respectively, to be driven low when the host CPU is reading or writing data to the S1D13705.
- RD/WR# is the read/write signal that is driven low when the CPU writes to the S1D13705 and is driven high when the CPU is doing a read from the S1D13705.
- WAIT# is a signal which is output from the S1D13705 to the host CPU that indicates when data is ready (read cycle) or accepted (write cycle) on the host bus. Since host CPU accesses to the S1D13705 may occur asynchronously to the display update, it is possible that contention may occur in accessing the S1D13705 internal registers and/or refresh memory. The WAIT# line resolves these contentions by forcing the host to wait until the resource arbitration is complete.
- The Bus Status (BS#) signal indicates that the address on the address bus is valid.
- The WE0# and RD# signals is not used in the bus interface for MC68K #1 and must be tied high (tied to IO V_{DD}).

1.4 MC68328 To S1D13705 Interface

Hardware Description

The interface between the MC68328 and the S1D13705 can be implemented using either the MC68K #1 or Generic #1 host bus interface of the S1D13705.

Using The MC68K #1 Host Bus Interface

The MC68328 multiplexes dual functions on some of its bus control pins (specifically UDS#, LDS#, and DTACK#). In implementations where all of these pins are available for use as bus control pins, then the S1D13705 interface is a straightforward implementation of the "MC68K #1" host bus interface. For further information on this host bus interface, refer to the "S1D13705 Hardware Functional Specification", document number X27A-A-001-02.

The following diagram shows a typical implementation of the MC68328 to S1D13705 using the MC68K #1 host bus interface.

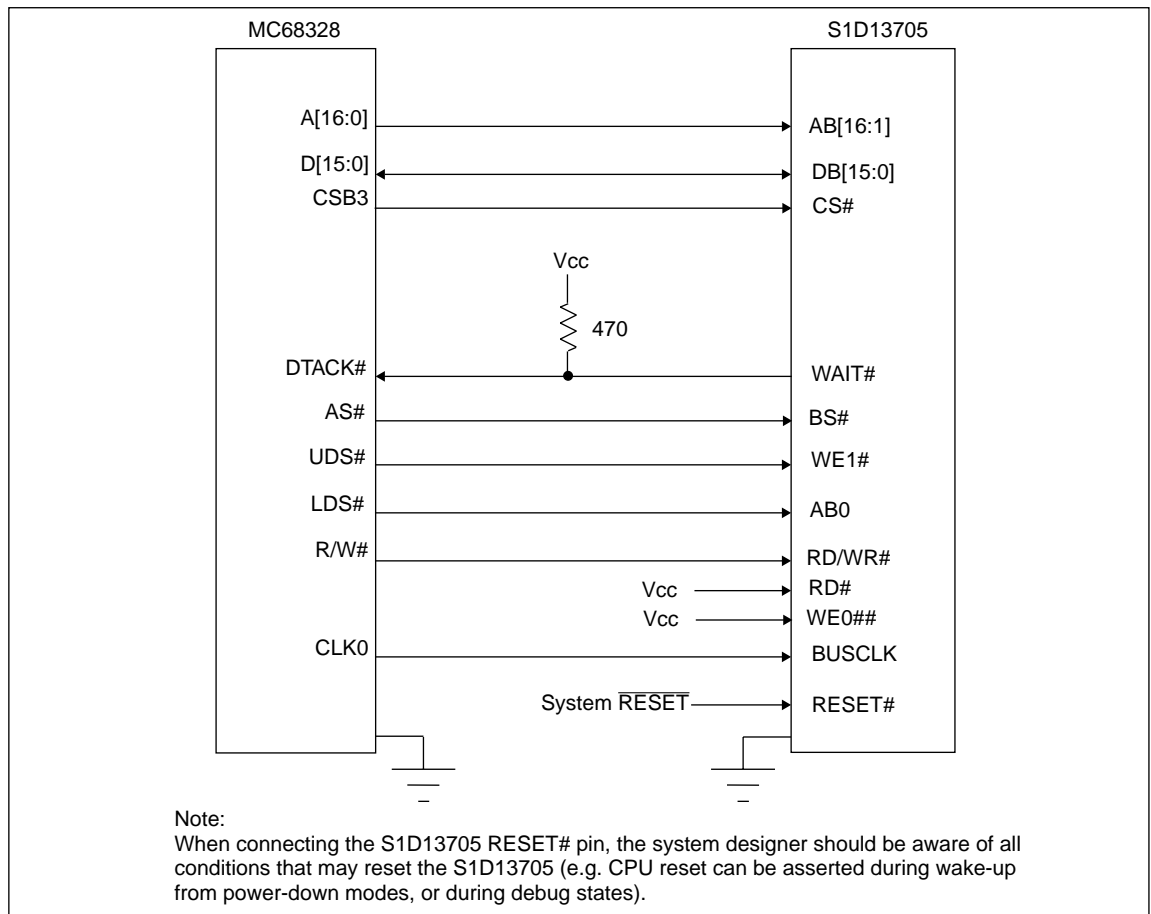

Figure 1-1 Typical Implementation of MC68328 to S1D13705 Interface - MC68K #1

Using The Generic #1 Host Bus Interface

If UDS# and/or LDS# are required for their alternate IO functions, then the MC68328 to S1D13705 interface may be implemented using the S1D13705 Generic #1 host bus interface. Note that in either case, the DTACK# signal must be made available for the S1D13705, since it inserts a variable number of wait states depending upon CPU/LCD synchronization and the LCD panel display mode. WAIT# must be inverted (using an inverter enabled by CS#) to make it an active high signal and thus compatible with the MC68328 architecture. A single resistor is used to speed up the rise time of the WAIT# (DTACK#) signal when terminating the bus cycle.

The following diagram shows a typical implementation of the MC68328 to S1D13705 using the Generic #1 host bus interface.

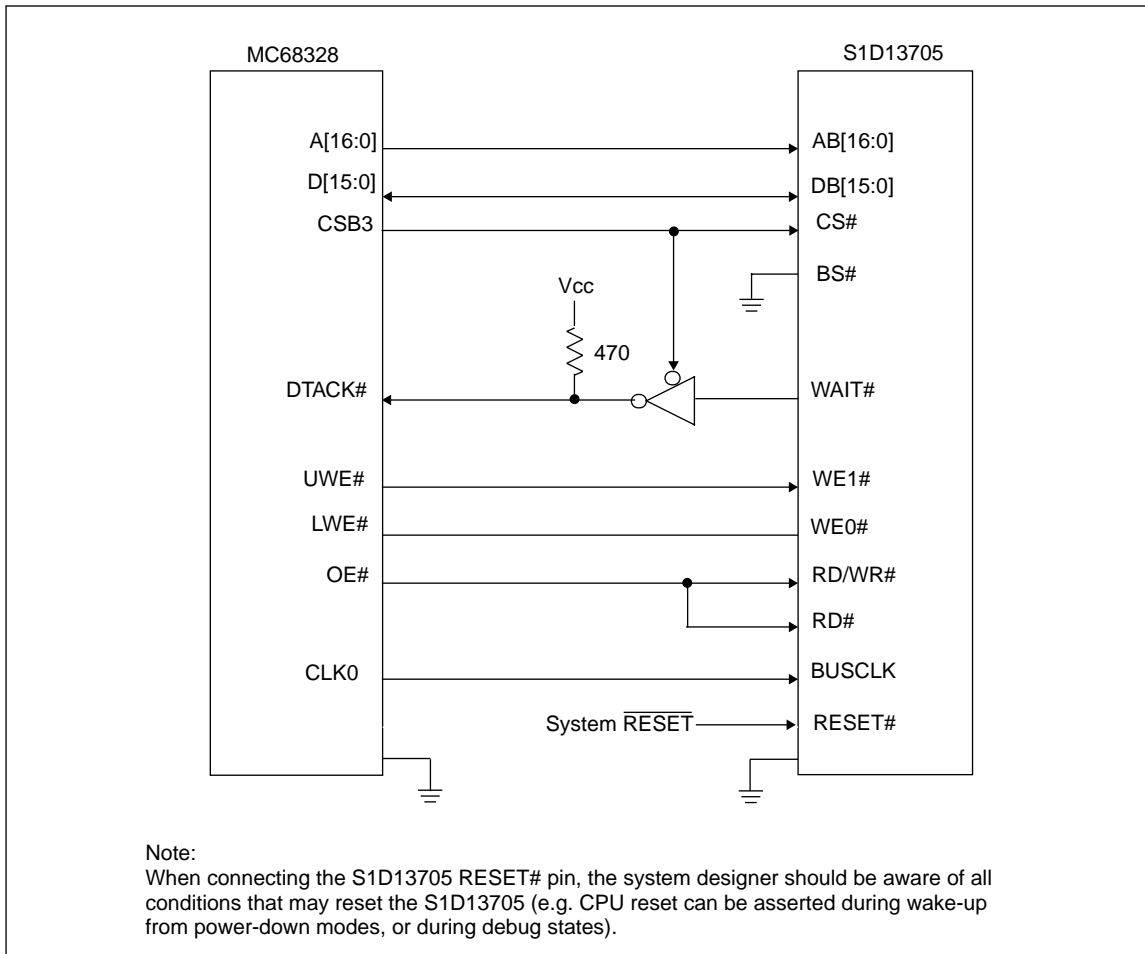

Figure 1-2 Typical Implementation of MC68328 to S1D13705 Interface - Generic #1

S1D13705 Hardware Configuration

The S1D13705 uses CNF3 through CNF0 and BS# to allow selection of the bus mode and other configuration data on the rising edge of RESET#. Refer to the "S1D13705 Hardware Functional Specification", document number X27A-A-001-02 for details.

The tables below show those configuration settings important to the MC68K #1 and Generic #1 host bus interfaces.

Table 1-2 Summary of Power-On/Reset Options

S1D13705	value on this pin at the rising edge of RESET# is used to configure: (1/0)	
Pin Name	0	1
CNF0	See "Table 1-3: Host Bus Interface Selection"	
CNF1		
CNF2		
CNF3	Little Endian	Big Endian



 = configuration for MC68328 support

Table 1-3 Host Bus Interface Selection

CNF2	CNF1	CNF0	BS#	Host Bus Interface
0	0	0	X	SH-4 interface
0	0	1	X	SH-3 interface
0	1	0	X	reserved
0	1	1	X	MC68K #1, 16-bit
1	0	0	X	reserved
1	0	1	X	MC68K #2, 16-bit
1	1	0	0	reserved
1	1	0	1	reserved
1	1	1	0	Generic #1, 16-bit
1	1	1	1	Generic #2, 16-bit

 = configuration for MC68328 using Generic #1 host bus interface
 = configuration for MC68328 using MC68K #1 host bus interface

MC68328 Chip Select Configuration

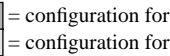
The S1D13705 requires a 128K byte address space for the display buffer and its internal registers. To accommodate this block size, it is preferable (but not required) to use one of the chip selects from groups A or B. Virtually any chip select other than CSA0 or CSD3 would be suitable for the S1D13705 interface.

In the example interface, chip select CSB3 is used to control the S1D1375. A 128K byte address space is used with the S1D13705 control registers mapped into the top 32 bytes of the 128K byte block and the 80K bytes of display buffer mapped to the starting address of the block. The chip select should have its RO (Read Only) bit set to 0, and the WAIT field (Wait states) should be set to 111b to allow the S1D13705 to terminate bus cycles externally.

1.5 Software

Test utilities and Windows® CE v2.0 display drivers are available for the S1D13705. Full source code is available for both the test utilities and the drivers.

The test utilities are configurable for different panel types using a program called 1375CFG, or by directly modifying the source. The Windows® CE v2.0 display drivers can be customized by the OEM for different panel types, resolutions and color depths only by modifying the source.

2 *INTERFACING TO THE MOTOROLA MPC821 MICROPROCESSOR*

2.1 *Introduction*

This application note describes the hardware and software environment required to interface the S1D13705 Embedded Memory LCD Controller and the Motorola MPC821 Processor.

2.2 *Interfacing to the MPC821*

The MPC8xx System Bus

The MPC8xx family of processors feature a high-speed synchronous system bus typical of modern RISC microprocessors. This section provides an overview of the operation of the CPU bus in order to establish interface requirements.

MPC821 Bus Overview

The MPC8xx microprocessor family uses a synchronous address and data bus. All IO is synchronous to a square-wave reference clock called MCLK (Master Clock). This clock runs at the machine cycle speed of the CPU core (typically 25 to 50 MHz). Most outputs from the processor change state on the rising edge of this clock. Similarly, most inputs to the processor are sampled on the rising edge.

Note: The external bus can run at one-half the CPU core speed using the clock control register. This is typically used when the CPU core is operated above 50 MHz.

The MPC821 can generate up to eight independent chip select outputs, each of which may be controlled by one of two types of timing generators: the General Purpose Chip Select Module (GPCM) or the User-Programmable Machine (UPM). Examples are given using the GPCM.

It should be noted that all Power PC microprocessors, including the MPC8xx family, use bit notation opposite from the convention used by most other microprocessor systems. Bit numbering for the MPC8xx always starts with zero as the most significant bit, and increments in value to the least-significant bit. For example, the most significant bits of the address bus and data bus are A0 and D0, while the least significant bits are A31 and D31.

The MPC8xx uses both a 32-bit address and data bus. A parity bit is supported for each of the four byte lanes on the data bus. Parity checking is done when data is read from external memory or peripherals, and generated by the MPC8xx bus controller on write cycles. All IO accesses are memory-mapped meaning there is no separate IO space in the Power PC architecture.

Support is provided for both on-chip (DMA controllers) and off-chip (other processors and peripheral controllers) bus masters.

The bus can support both normal and burst cycles. Burst memory cycles are used to fill on-chip cache memory, and for certain on-chip DMA operations. Normal cycles are used for all other data transfers.

Normal (Non-Burst) Bus Transactions

A data transfer is initiated by the bus master by placing the memory address on address lines A0 through A31 and driving \overline{TS} (Transfer Start) low for one clock cycle. Several control signals are also provided with the memory address:

- TSIZ[0:1] (Transfer Size) -- indicates whether the bus cycle is 8, 16, or 32-bit.
- RD/ \overline{WR} -- set high for read cycles and low for write cycles.
- AT[0:3] (Address Type Signals) -- provides more detail on the type of transfer being attempted.

When the peripheral device being accessed has completed the bus transfer, it asserts \overline{TA} (Transfer Acknowledge) for one clock cycle to complete the bus transaction. Once \overline{TA} has been asserted, the MPC821 will not start another bus cycle until \overline{TA} has been de-asserted. The minimum length of a bus transaction is two bus clocks.

Figure 2-1 “Power PC Memory Read Cycle” illustrates a typical memory read cycle on the Power PC system bus.

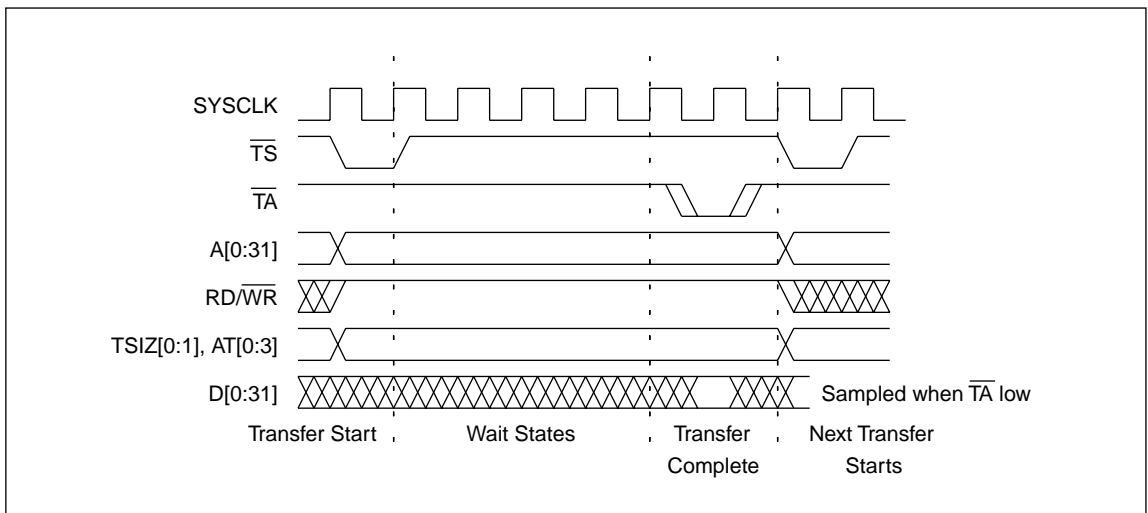

Figure 2-1 Power PC Memory Read Cycle

Figure 2-2 “Power PC Memory Write Cycle” illustrates a typical memory write cycle on the Power PC system bus.

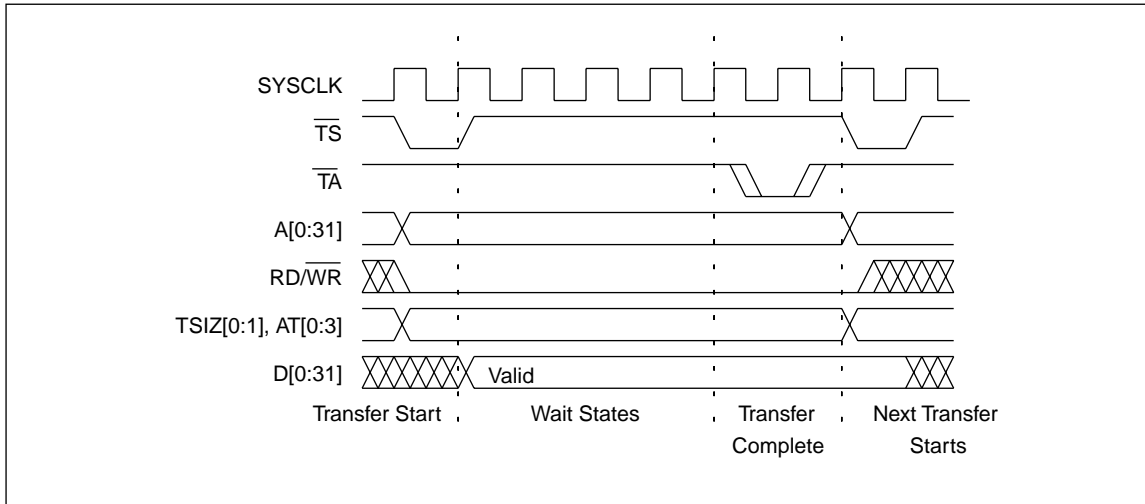

Figure 2-2 Power PC Memory Write Cycle

If an error occurs, \overline{TEA} (Transfer Error Acknowledge) is asserted and the bus cycle is aborted. For example, a peripheral device may assert \overline{TEA} if a parity error is detected, or the MPC821 bus controller may assert \overline{TEA} if no peripheral device responds at the addressed memory location within a bus time-out period.

For 32-bit transfers, all data lines (D[0:31]) are used and the two low-order address lines A30 and A31 are ignored. For 16-bit transfers, data lines D0 through D15 are used and address line A30 is ignored. For 8-bit transfers, data lines D0 through D7 are used and all address lines (A[0:31]) are used.

Note: This assumes that the Power PC core is operating in big endian mode (typically the case for embedded systems).

Burst Cycles

Burst memory cycles are used to fill on-chip cache memory and to carry out certain on-chip DMA operations. They are very similar to normal bus cycles with the following exceptions:

- Always 32-bit.
- Always attempt to transfer four 32-bit words sequentially.
- Always address longword-aligned memory (i.e. A30 and A31 are always 0:0).
- Do not increment address bits A28 and A29 between successive transfers; the addressed device must increment these address bits internally.

If a peripheral is not capable of supporting burst cycles, it can assert Burst Inhibit (\overline{BI}) simultaneously with \overline{TA} , and the processor will revert to normal bus cycles for the remaining data transfers.

Burst cycles are mainly intended to facilitate cache line fills from program or data memory. They are normally not used for transfers to/from IO peripheral devices such as the S1D13705, therefore the interfaces described in this document do not attempt to support burst cycles. However, the example interfaces include circuitry to detect the assertion of \overline{BDIP} and respond with \overline{BI} if caching is accidentally enabled for the S1D13705 address space.

Memory Controller Module

General-Purpose Chip Select Module (GPCM)

The General-Purpose Chip Select Module (GPCM) is used to control memory and peripheral devices which do not require special timing or address multiplexing. In addition to the chip select output, it can generate active-low Output Enable (\overline{OE}) and Write Enable (\overline{WE}) signals compatible with most memory and x86-style peripherals. The MPC821 bus controller also provides a Read/Write (RD/ \overline{WR}) signal which is compatible with most 68K peripherals.

The GPCM is controlled by the values programmed into the Base Register (BR) and Option Register (OR) of the respective chip select. The Option Register sets the base address, the block size of the chip select, and controls the following timing parameters:

- The ACS bit field allows the chip select assertion to be delayed with respect to the address bus valid, by 0, 1/4, or 1/2 clock cycle.
- The CSNT bit causes chip select and \overline{WE} to be negated 1/2 clock cycle earlier than normal.
- The TRLX (relaxed timing) bit will insert an additional one clock delay between assertion of the address bus and chip select. This accommodates memory and peripherals with long setup times.
- The EHTR (Extended hold time) bit will insert an additional 1-clock delay on the first access to a chip select.
- Up to 15 wait states may be inserted, or the peripheral can terminate the bus cycle itself by asserting \overline{TA} (Transfer Acknowledge).
- Any chip select may be programmed to assert \overline{BI} (Burst Inhibit) automatically when its memory space is addressed by the processor core.

User-Programmable Machine (UPM)

The UPM is typically used to control memory types, such as Dynamic RAMs, which have complex control or address multiplexing requirements. The UPM is a general purpose RAM-based pattern generator which can control address multiplexing, wait state generation, and five general-purpose output lines on the MPC821. Up to 64 pattern locations are available, each 32 bits wide. Separate patterns may be programmed for normal accesses, burst accesses, refresh (timer) events, and exception conditions. This flexibility allows almost any type of memory or peripheral device to be accommodated by the MPC821.

In this application note, the GPCM is used instead of the UPM, since the GPCM has enough flexibility to accommodate the S1D13705 and it is desirable to leave the UPM free to handle other interfacing duties, such as EDO DRAM.

2.3 S1D13705 Host Bus Interface

This section is a summary of the host bus interface mode used on the S1D13705 to interface to the MPC821.

The S1D13705 implements a 16-bit interface to the host microprocessor which may operate in one of several modes compatible with most of the popular embedded microprocessor families. The interface mode used for the MPC821 is:

- Generic #1 (Chip Select, plus individual Read Enable/Write Enable for each byte).

Host Bus Interface Modes

Table 2-1 Host Bus Interface Pin Mapping

S1D13705 Pin Names	Generic #1
AB[15:1]	A[15:1]
AB0	A0
DB[15:0]	D[15:0]
WE1#	WE1#
CS#	External Decode
BCLK	BCLK
BS#	connect to V _{SS}
RD/WR#	RD1#
RD#	RD0#
WE0#	WE0#
WAIT#	WAIT#
RESET#	RESET#

For details on configuration, refer to the “*S1D13705 Hardware Functional Specification*”, document number X27A-A-001-01.

Generic #1 Host Bus Interface Mode

Generic #1 host bus interface mode is the most general and least processor-specific host bus interface mode on the S1D13705. The Generic # 1 host bus interface mode was chosen for this interface due to the simplicity of its timing.

The host bus interface requires the following signals:

- BUSCLK is a clock input which is required by the S1D13705 host interface. It is separate from the input clock (CLKI) and is typically driven by the host CPU system clock.
- The address inputs AB0 through AB16, and the data bus DB0 through DB15, connect directly to the CPU address and data bus, respectively. On 32-bit big endian architectures such as the Power PC, the data bus would connect to the high-order data lines; on little endian hosts, or 16-bit big endian hosts, they would connect to the low-order data lines. The hardware engineer must ensure that CNF3 selects the proper endian mode upon reset.
- Chip Select (CS#) is driven by decoding the high-order address lines to select the proper IO or memory address space.
- WE0# and WE1# are write enables for the low-order and high-order bytes, respectively, to be driven low when the host CPU is writing data to the S1D13705.
- RD# and RD/WR# are read enables for the low-order and high-order bytes, respectively, to be driven low when the host CPU is reading data from the S1D13705.
- WAIT# is a signal output from the S1D13705 that indicates the host CPU must wait until data is ready (read cycle) or accepted (write cycle) on the host bus. Since host CPU accesses to the S1D13705 may occur asynchronously to the display update, it is possible that contention may occur in accessing the S1D13705 internal registers and/or refresh memory. The WAIT# line resolves these contentions by forcing the host to wait until the resource arbitration is complete. This signal is active low and may need to be inverted if the host CPU wait state signal is active high.
- The Bus Status (BS#) signal is not used in the bus interface for Generic #1 mode. However, BS# is used to configure the S1D13705 for Generic #1 mode and should be tied low (connected to GND).

2.4 MPC821 to S1D13705 Interface

Hardware Description

The interface between the S1D13705 and the MPC821 requires minimal glue logic. One inverter is required to change the polarity of the WAIT# signal (an active low signal) to insert wait states in the bus cycle. The MPC821 Transfer Acknowledge signal (\overline{TA}) is an active low signal which ends the current bus cycle. The inverter is enabled using CS# so that \overline{TA} is not driven by the S1D13705 during non-S1D13705 bus cycles. A single resistor is used to speed up the rise time of the WAIT# (\overline{TA}) signal when terminating the bus cycle.

BS# (bus start) is not used in this implementation and should be tied low (connected to GND).

The following diagram shows a typical implementation of the MPC821 to S1D13705 interface.

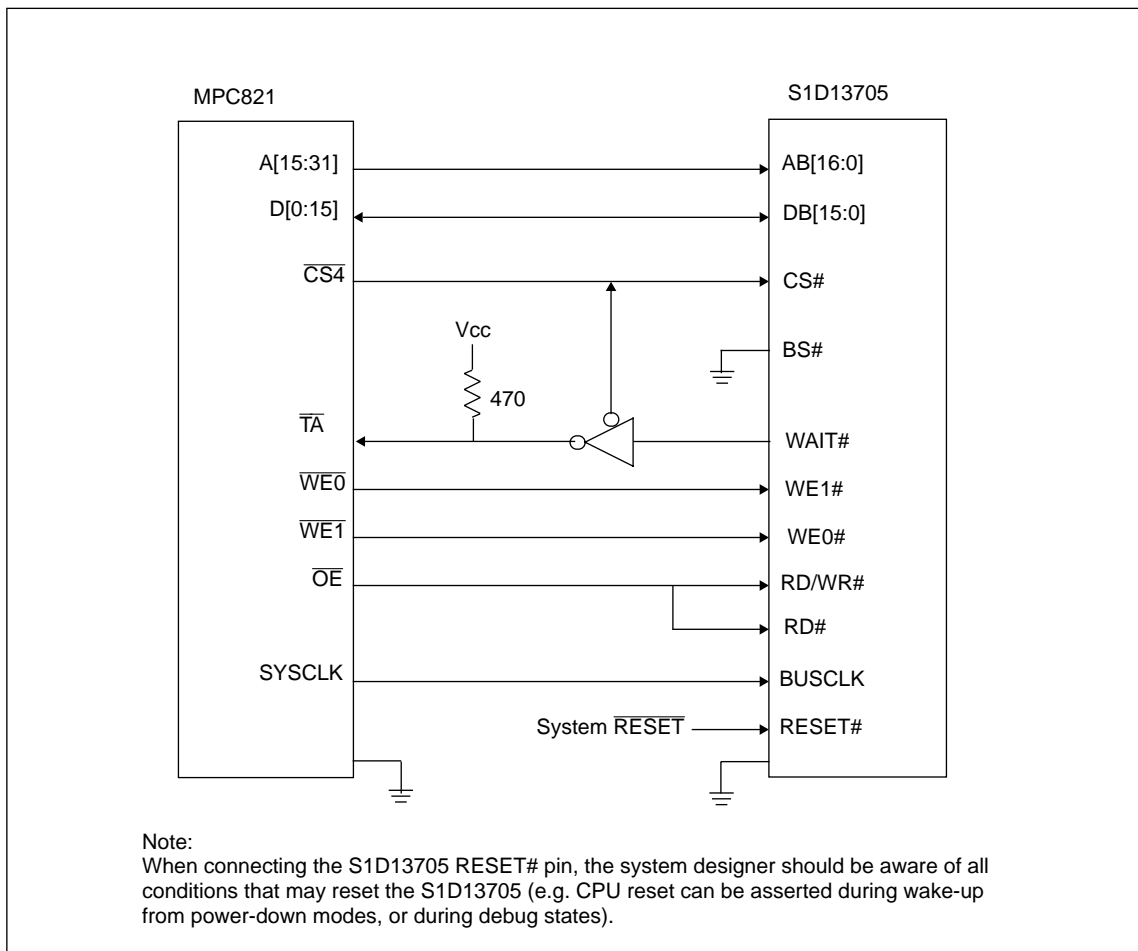

Figure 2-3 Typical Implementation of MPC821 to S1D13705 Interface

MPC821ADS Evaluation Board Hardware Connections

The following table details the connections between the pins and signals of the MPC821 and the S1D13705.

Table 2-2 List of Connections from MPC821ADS to S1D13705

MPC821 Signal Name	MPC821ADS Connector and Pin Name	S1D13705 Signal Name
Vcc	P6-A1, P6-B1	Vcc
A15	P6-D20	A16
A16	P6-B24	A15
A17	P6-C24	A14
A18	P6-D23	A13
A19	P6-D22	A12
A20	P6-D19	A11
A21	P6-A19	A10
A22	P6-D28	A9
A23	P6-A28	A8
A24	P6-C27	A7
A25	P6-A26	A6
A26	P6-C26	A5
A27	P6-A25	A4
A28	P6-D26	A3
A29	P6-B25	A2
A30	P6-B19	A1
A31	P6-D17	A0
D0	P12-A9	D15
D1	P12-C9	D14
D2	P12-D9	D13
D3	P12-A8	D12
D4	P12-B8	D11
D5	P12-D8	D10
D6	P12-B7	D9
D7	P12-C7	D8
D8	P12-A15	D7
D9	P12-C15	D6
D10	P12-D15	D5
D11	P12-A14	D4
D12	P12-B14	D3
D13	P12-D14	D2
D14	P12-B13	D1
D15	P12-C13	D0
SRESET	P9-D15	RESET#
SYSCLK	P9-C2	BUSCLK
CS4	P6-D13	CS#
TA	P6-B6 to inverter enabled by CS#	WAIT#
WE0	P6-B15	WE1#
WE1	P6-A14	WE0#
OE	P6-B16	RD/WR#, RD#
GND	P12-A1, P12-B1, P12-A2, P12-B2, P12-A3, P12-B3, P12-A4, P12-B4, P12-A5, P12-B5, P12-A6, P12-B6, P12-A7	Vss

Note: The bit numbering of the Power PC bus signals is reversed from the normal convention, e.g.: the most significant address bit is A0, the next is A1, A2, etc.

S1D13705 Hardware Configuration

The S1D13705 uses CNF3 through CNF0 and BS# to allow selection of the bus mode and other configuration data on the rising edge of RESET#. Refer to the “S1D13705 Hardware Functional Specification”, document number X27A-A-001-02 for details.

The tables below show only those configuration settings important to the MPC821 interface. The settings are very similar to the ISA bus with the following exceptions:

- the WAIT# signal is active high rather than active low.
- the Power PC is big endian rather than little endian.

Table 2-3 Configuration Settings

Signal	Low	High
CNF0	See “Host Bus Interface Selection” table4-3 below.	See “Host Bus Interface Selection” table4-3 below.
CNF1		
CNF2		
CNF3	Little Endian	Big Endian

= configuration for MPC821 host bus interface

Table 2-4 Host Bus Interface Selection

CNF2	CNF1	CNF0	BS#	Host Bus Interface
<input type="checkbox"/>	<input type="checkbox"/>	<input type="checkbox"/>	<input type="checkbox"/>	Generic #1, 16-bit

= configuration for MPC821 host bus interface

MPC821 Chip Select Configuration

The DRAM on the MPC821 ADS board extends from address 0 through 3F FFFFh, so the S1D13705 is addressed starting at 40 0000h. The S1D13705 uses a 128K byte segment of memory starting at this address, with the first 80K bytes used for the display buffer and the upper 32 bytes of this memory block used for the S1D13705 internal registers.

Chip select 4 is used to control the S1D13705. The following options are selected in the base address register (BR4):

- BA (0:16) = 0000 0000 0100 0000 0 - set starting address of S1D13705 to 40 0000h
- AT (0:2) = 0 - ignore address type bits
- PS (0:1) = 1:0 - memory port size is 16 bits
- PARE = 0 - disable parity checking
- WP = 0 - disable write protect
- MS (0:1) = 0:0 - select General Purpose Chip Select module to control this chip select
- V = 1 - set valid bit to enable chip select

The following options were selected in the option register (OR4):

- AM (0:16) = 1111 1111 1100 0000 0 - mask all but upper 10 address bits; S1D13705 consumes 4M byte of address space
- ATM (0:2) = 0 - ignore address type bits
- CSNT = 0 - normal $\overline{CS}/\overline{WE}$ negation
- ACS (0:1) = 1:1 - delay \overline{CS} assertion by 1/2 clock cycle from address lines
- BI = 1 - assert Burst Inhibit
- SCY (0:3) = 0 - wait state selection; this field is ignored since external transfer acknowledge is used; see SETA below
- SETA = 1 - the S1D13705 generates an external transfer acknowledge using the WAIT# line
- TRLX = 0 - normal timing
- EHTR = 0 - normal timing

Test Software

The test software to exercise this interface is very simple. It configures chip select 4 on the MPC821 to map the S1D13705 to an unused 128k byte block of address space and loads the appropriate values into the option register for CS4. At that point the software runs in a tight loop reading the S1D13705 Revision Code Register REG[00h], which allows monitoring of the bus timing on a logic analyzer.

The source code for this test routine is as follows:

```
BR4      equ      $120          ; CS4 base register
OR4      equ      $124          ; CS4 option register
MemStart equ      $40           ; upper word of S1D13705 start address
RevCodeReg equ     1FFE0        ; address of Revision Code Register

Start    mfspr     r1,IMMR       ; get base address of internal registers
         andis.   r1,r1,$ffff    ; clear lower 16 bits to 0
         andis.   r2,r0,0        ; clear r2
         oris     r2,r2,MemStart ; write base address
         ori      r2,r2,$0801    ; port size 16 bits; select GPCM; enable
         stw     r2,BR4(r1)     ; write value to base register
         andis.   r2,r0,0        ; clear r2
         oris     r2,r2,$ffc0    ; address mask - use upper 10 bits
         ori      r2,r2,$0708   ; normal CS negation; delay CS 1/2 clock;
                               ; inhibit burst
         stw     r2,OR4(r1)     ; write to option register
         andis.   r1,r0,0        ; clear r1
         oris     r1,r1,MemStart ; point r1 to start of S1D13705 mem space
Loop     lbz     r0,RevCodeReg(r1) ; read revision code into r1
         b       Loop          ; branch forever

end
```

This code was entered into the memory of the MPC821ADS using the line-by-line assembler in MPC8BUG, the debugger provided with the ADS board. It was executed on the ADS and a logic analyzer was used to verify operation of the interface hardware.

Note: MPC8BUG does not support comments or symbolic equates; these have been added for clarity.

It is important to note that when the MPC821 comes out of reset, its on-chip caches and MMU are disabled. If the data cache is enabled, then the MMU must be set up so that the S1D13705 memory block is tagged as non-cacheable, to ensure that accesses to the S1D13705 will occur in proper order, and also to ensure that the MPC821 does not attempt to cache any data read from or written to the S1D13705 or its display buffer.

2.5 Software

Test utilities and Windows® CE v2.0 display drivers are available for the S1D13705. Full source code is available for both the test utilities and the drivers.

The test utilities are configurable for different panel types using a program called 1375CFG, or by directly modifying the source. The Windows® CE v2.0 display drivers can be customized by the OEM for different panel types, resolutions and color depths only by modifying the source.

3 INTERFACING TO THE MOTOROLA MCF5307 “COLDFIRE” MICROPROCESSOR

3.1 Introduction

This application note describes the hardware required to interface the S1D13705 Embedded Memory LCD Controller and the Motorola MCF5307 Processor. The pairing of these two devices results in an embedded system offering impressive display capability with very low power consumption.

3.2 Interfacing to the MCF5307

The MCF5307 System Bus

The MCF5200/5300 family of processors feature a high-speed synchronous system bus typical of modern microprocessors. This section is an overview of the operation of the CPU bus to establish interface requirements.

Overview

The MCF5307 microprocessor family uses a synchronous address and data bus, very similar in architecture to the MC68040 and MPC8xx. All outputs and inputs are timed with respect to a square-wave reference clock called BCLK0 (Master Clock). This clock runs at a software-selectable divisor rate from the machine cycle speed of the CPU core, typically 20 to 33 MHz. Both the address and the data bus are 32 bits in width. All IO accesses are memory-mapped; there is no separate IO space in the Coldfire architecture.

The bus can support two types of cycles, normal and burst. Burst memory cycles are used to fill on-chip cache memories, and for certain on-chip DMA operations. Normal cycles are used for all other data transfers.

Normal (Non-Burst) Bus Transactions

A data transfer is initiated by the bus master by placing the memory address on address lines A31 through A0 and driving \overline{TS} (Transfer Start) low for one clock cycle. Several control signals are also provided with the memory address:

- SIZ[1:0] (Transfer Size), which indicate whether the bus cycle is 8, 16, or 32 bits in width.
- R/\overline{W} , which is high for read cycles and low for write cycles.
- A set of transfer type signals (TT[1:0]) which provide more detail on the type of transfer being attempted.
- \overline{TIP} (Transfer In Progress), which is asserted whenever a bus cycle is active.

When the peripheral device being accessed has completed the bus transfer, it asserts \overline{TA} (Transfer Acknowledge) for one clock cycle, completing the bus transaction. Once \overline{TA} has been asserted, the MCF5307 will not start another bus cycle until \overline{TA} has been de-asserted. The minimum length of a bus transaction is two bus clocks.

Figure 3-1 illustrates a typical memory read cycle on the MCF5307 system bus, and Figure 3-2 illustrates a memory write cycle.

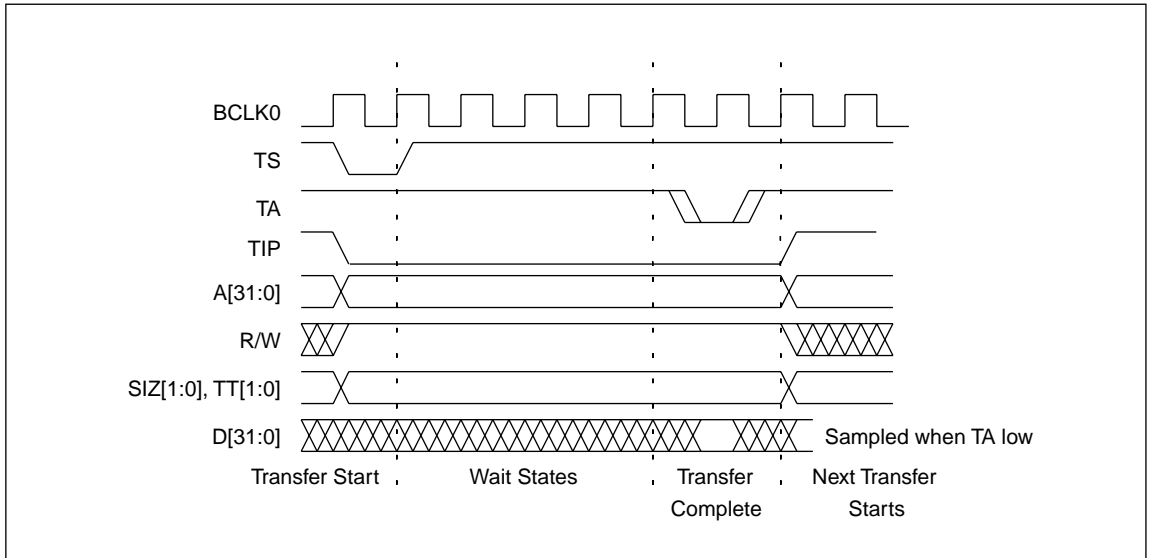

Figure 3-1 MCF5307 Memory Read Cycle

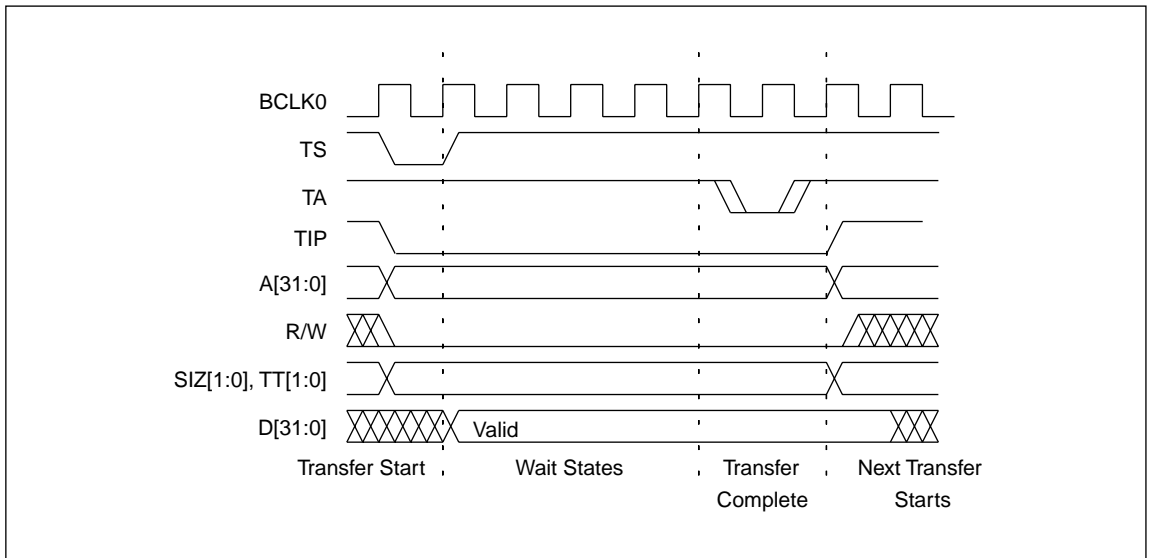

Figure 3-2 MCF5307 Memory Write Cycle

Burst Cycles

Burst cycles are very similar to normal cycles, except that they occur as a series of four back-to-back, 32-bit memory reads or writes, with the \overline{TIP} (Transfer In Progress) output asserted continuously through the burst. Burst memory cycles are mainly intended to facilitate cache line fill from program or data memory; they are typically not used for transfers to or from IO peripheral devices such as the S1D13705. The MCF5307 chip selects provide a mechanism to disable burst accesses for peripheral devices which are not able to support them.

Chip-Select Module

In addition to generating eight independent chip-select outputs, the MCF5307 Chip Select Module can generate active-low Output Enable (\overline{OE}) and Write Enable (\overline{BWE}) signals compatible with most memory and x86-style peripherals. The MCF5307 bus controller also provides a Read/Write (R/\overline{W}) signal which is compatible with most 68K peripherals.

Chip selects 0 and 1 can be programmed independently to respond to any base address and block size. Chip select 0 can be active immediately after reset, and is typically used to control a boot ROM. Chip select 1 is likewise typically used to control a large static or dynamic RAM block.

Chip selects 2 through 7 have fixed block sizes of 2M bytes each. Each has a unique, fixed offset from a common, programmable starting address. These chip selects are well-suited to typical IO addressing requirements.

Each chip select may be individually programmed for port size (8/16/32 bits), 0 to 15 wait states or external acknowledge, address space type, burst or non-burst cycle support, and write protect.

3.3 S1D13705 Bus Interface

This section is a summary of the host bus interface mode used on the S1D13705 to interface to the MCF5307.

The S1D13705 implements a 16-bit interface to the host microprocessor which may operate in one of several modes compatible with most of the popular embedded microprocessor families. The interface mode used for the MCF5307 is:

- Generic #1 (Chip Select, plus individual Read Enable/Write Enable for each byte).

Host Bus Pin Connection

Table 3-1 Host Bus Interface Pin Mapping

S1D13705 Pin Names	Generic #1
AB[15:1]	A[15:1]
AB0	A0
DB[15:0]	D[15:0]
WE1#	WE1#
CS#	External Decode
BCLK	BCLK
BS#	connect to V_{SS}
RD/WR#	RD1#
RD#	RDO#
WE0#	WE0#
WAIT#	WAIT#
RESET#	RESET#

For details on configuration, refer to the “S1D13705 Hardware Functional Specification”, document number X27A-A-001-02.

Generic #1 Interface Mode

Generic #1 interface mode is the most general and least processor-specific interface mode on the S1D13705. The Generic # 1 interface mode was chosen for this interface due to the simplicity of its timing.

The interface requires the following signals:

- BUSCLK is a clock input which is required by the S1D13705 host interface. It is separate from the input clock (CLKI) and is typically driven by the host CPU system clock.
- The address inputs AB0 through AB16, and the data bus DB0 through DB15, connect directly to the CPU address and data bus, respectively. On 32-bit big endian architectures such as the Power PC, the data bus would connect to the high-order data lines; on little endian hosts, or 16-bit big endian hosts, they would connect to the low-order data lines. The hardware engineer must ensure that CNF3 selects the proper endian mode upon reset.
- Chip Select (CS#) is driven by decoding the high-order address lines to select the proper register and memory address space.
- WE0# and WE1# are write enables for the low-order and high-order bytes, respectively, to be driven low when the host CPU is writing data to the S1D13705.
- RD# and RD/WR# are read enables for the low-order and high-order bytes, respectively, to be driven low when the host CPU is reading data from the S1D13705.
- WAIT# is a signal output from the S1D13705 that indicates the host CPU must wait until data is ready (read cycle) or accepted (write cycle) on the host bus. Since host CPU accesses to the S1D13705 may occur asynchronously to the display update, it is possible that contention may occur in accessing the S1D13705 internal registers and/or refresh memory. The WAIT# line resolves these contentions by forcing the host to wait until the resource arbitration is complete. This signal is active low and may need to be inverted if the host CPU wait state signal is active high.
- The Bus Status (BS#) signal is not used in the bus interface for Generic #1 mode. However, BS# is used to configure the S1D13705 for Generic #1 mode and should be tied low (connected to GND).

3.4 MCF5307 To S1D13705 Interface

Hardware Description

The S1D13705 is interfaced to the MCF5307 with a minimal amount of glue logic. One inverter is required to change the polarity of the WAIT# signal, which is an active low signal to insert wait states in the bus cycle, while the MCF5307's Transfer Acknowledge signal (\overline{TA}) is an active low signal to end the current bus cycle. The inverter is enabled by CS# so that \overline{TA} is not driven by the S1D13705 during non-S1D13705 bus cycles. A single resistor is used to speed up the rise time of the WAIT# (\overline{TA}) signal when terminating the bus cycle.

The following diagram shows a typical implementation of the MCF5307 to S1D13705 interface.

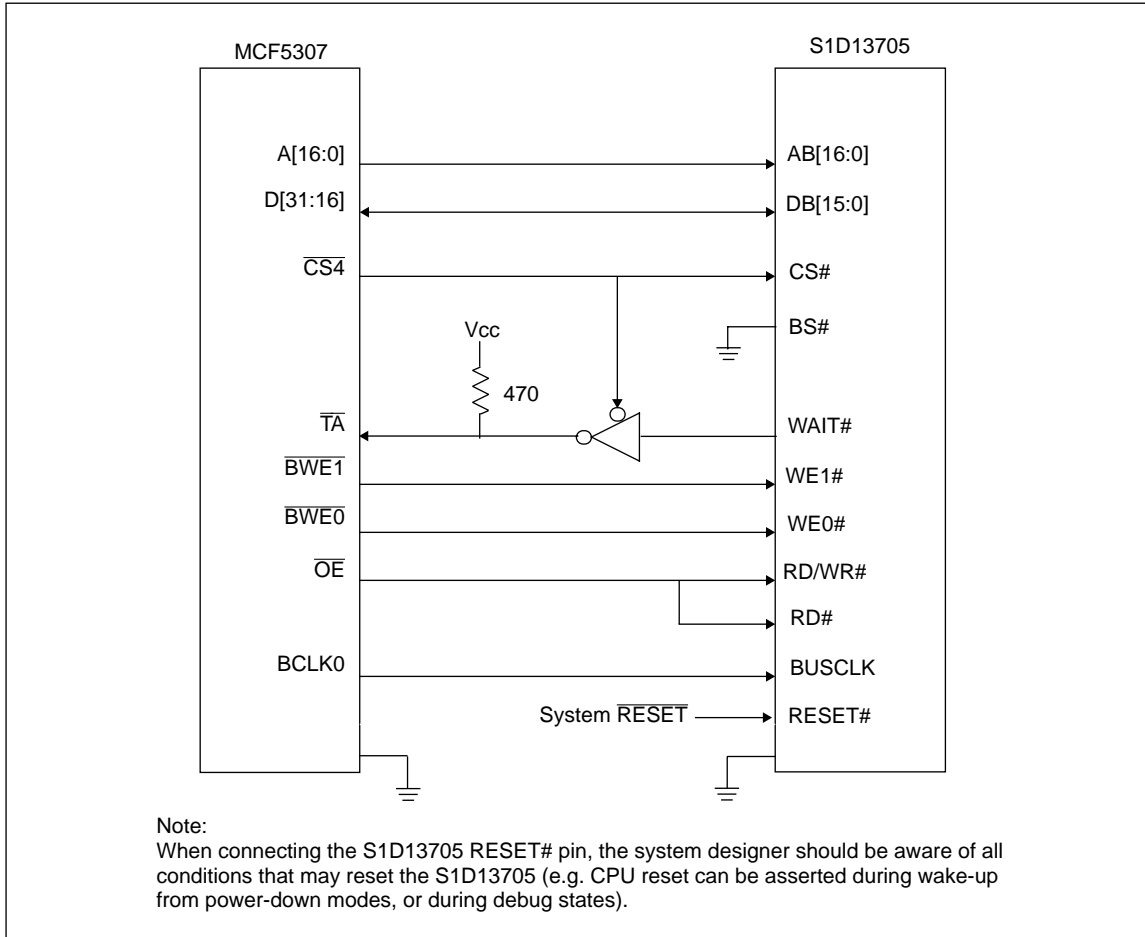

Figure 3-3 Typical Implementation of MCF5307 to S1D13705 Interface

S1D13705 Hardware Configuration

The S1D13705 uses CNF3 through CNF0 and BS# to allow selection of the bus mode and other configuration data on the rising edge of RESET#. Table 3-2, "Summary of Power-On/Reset Options," on page 5-22 and Table 3-3, "Host Bus Interface Selection," on page 5-22 shows the settings used for the S1D13705 in this interface.

Table 3-2 Summary of Power-On/Reset Options

S1D13705 Pin Name	value on this pin at the rising edge of RESET# is used to configure: (0/1)	
	0	1
CNF0	See "Host Bus Interface Selection" table3-3	See "Host Bus Interface Selection" table3-3 below.
CNF1	below.	
CNF2		
CNF3	Little Endian	Big Endian

= configuration for MFC5307 support

Table 3-3 Host Bus Interface Selection

CNF2	CNF1	CNF0	BS#	Host Bus Interface
1	1	1	0	Generic #1, 16-bit

= configuration for MFC5307 support

MCF5307 Chip Select Configuration

Chip Selects 0 and 1 have programmable block sizes from 64K bytes through 2G bytes. However, these chip selects would normally be needed to control system RAM and ROM. Therefore, one of the IO chip selects CS2 through CS7 is required to address the entire address space of the S1D13705. These IO chip selects have a fixed, 2M byte block size. In the example interface, chip select 4 is used to control the S1D13705. The S1D13705 only uses a 128K byte block with its 80K byte display buffer residing at the start of this 128K byte block and its internal registers occupying the last 32 bytes of this block. This block of memory will be shadowed over the entire 2M byte space. The CSBAR register should be set to the upper 8 bits of the desired base address.

The following options should be selected in the chip select mask registers (CSMR4/5):

- WP = 0 - disable write protect
- AM = 0 - enable alternate bus master access to the S1D13705
- C/I = 1 - disable CPU space access to the S1D13705
- SC = 1 - disable Supervisor Code space access to the S1D13705
- SD = 0 - enable Supervisor Data space access to the S1D13705
- UC = 1 - disable User Code space access to the S1D13705
- UD = 0 - enable User Data space access to the S1D13705
- V = 1 - global enable ("Valid") for the chip select

The following options should be selected in the chip select control registers (CSCR4/5):

- WS0-3 = 0 - no internal wait state setting
- AA = 0 - no automatic acknowledgment
- PS (1:0) = 1:0 - memory port size is 16 bits
- BEM = 0 - Byte enable/write enable active on writes only
- BSTR = 0 - disable burst reads
- BSTW = 0 - disable burst writes

3.5 Software

Test utilities and Windows® CE v2.0 display drivers are available for the S1D13705. Full source code is available for both the test utilities and the drivers.

The test utilities are configurable for different panel types using a program called 1375CFG, or by directly modifying the source. The Windows® CE v2.0 display drivers can be customized by the OEM for different panel types, resolutions and color depths only by modifying the source.

4 INTERFACING TO THE PC CARD BUS

4.1 Introduction

This application note describes the hardware and software environment required to interface the S1D13705 Embedded Memory LCD Controller and the PC Card (PCMCIA) bus.

4.2 Interfacing to the PC Card Bus

The PC Card System Bus

PC Card technology has gained wide acceptance in the mobile computing field as well as in other markets due to its portability and ruggedness. This section is an overview of the operation of the 16-bit PC Card interface conforming to the PCMCIA 2.0/JEIDA 4.1 Standard (or later).

PC Card Overview

The 16-bit PC Card provides a 26-bit address bus and additional control lines which allow access to three 64M byte address ranges. These ranges are used for common memory space, IO space, and attribute memory space. Common memory may be accessed by a host system for memory read and write operations. Attribute memory is used for defining card specific information such as configuration registers, card capabilities, and card use. IO space maintains software and hardware compatibility with hosts such as the Intel x86 architecture, which address peripherals independently from memory space.

Bit notation follows the convention used by most microprocessors, the high bit is the most significant. Therefore, signals A25 and D15 are the most significant bits for the address and data bus respectively.

Support is provided for on-chip DMA controllers.

PC Card bus signals are asynchronous to the host CPU bus signals. Bus cycles are started with the assertion of either the CE1# and/or the CE2# card enable signals. The cycle ends once these signals are de-asserted. Bus cycles can be lengthened using the WAIT# signal.

Note: The PCMCIA 2.0/JEIDA 4.1 (and later) PC Card Standard support the two signals WAIT# and RESET which are not supported in earlier versions of the standard. The WAIT# signal allows for asynchronous data transfers for memory, attribute, and IO access cycles. The RESET signal allows resetting of the card configuration by the reset line of the host CPU.

Memory Access Cycles

A data transfer is initiated when the memory address is placed on the PC Card bus and one, or both, of the card enable signals (CE1# and CE2#) are driven low. REG# must be kept inactive. If only CE1# is driven low, 8-bit data transfers are enabled and A0 specifies whether the even or odd data byte appears on data bus lines D[7:0]. If both CE1# and CE2# are driven low, a 16-bit word transfer takes place. If only CE2# is driven low, an odd byte transfer occurs on data lines D[15:8].

During a read cycle, OE# (output enable) is driven low. A write cycle is specified by driving OE# high and driving the write enable signal (WE#) low. The cycle can be lengthened by driving WAIT# low for the time needed to complete the cycle.

Figure 4-1 and Figure 4-2 illustrate typical memory access cycles on the PC Card bus.

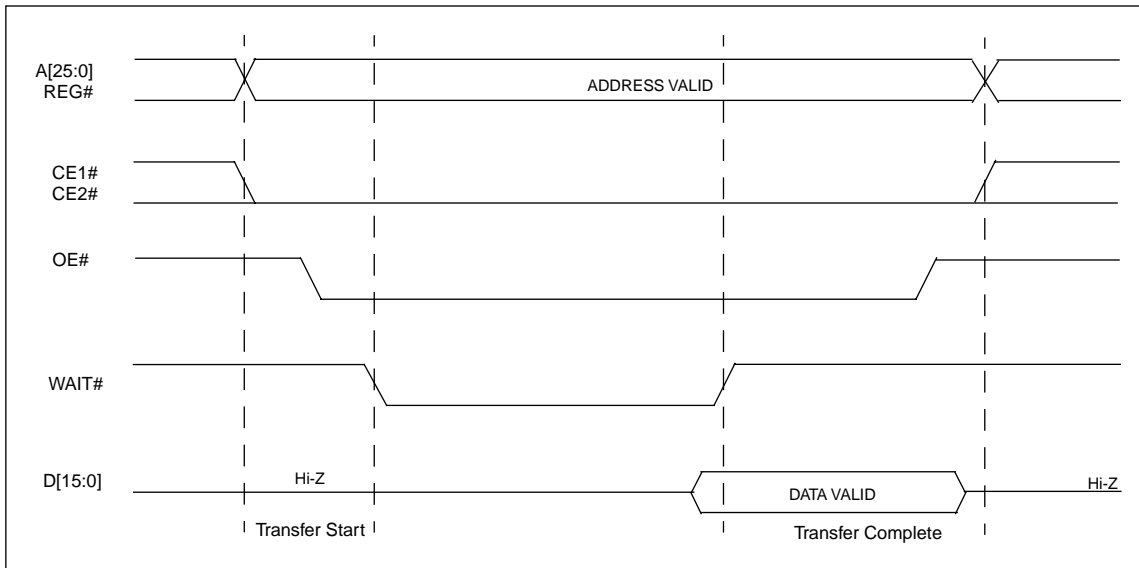

Figure 4-1 PC Card Read Cycle

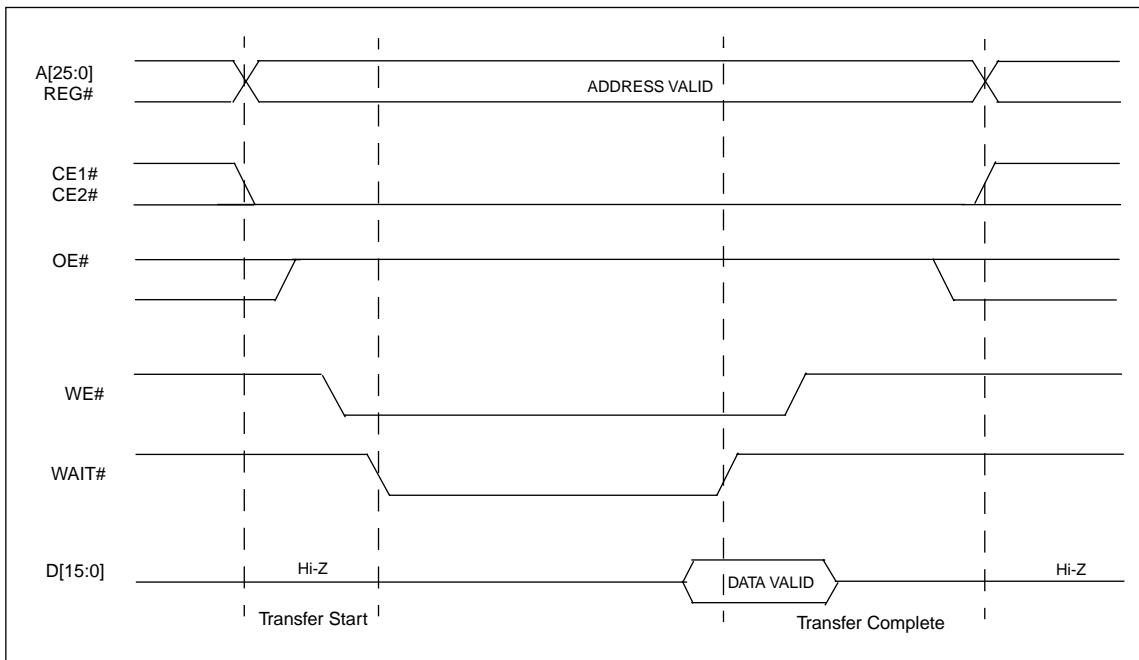

Figure 4-2 PC Card Write Cycle

4.3 S1D13705 Bus Interface

This section is a summary of the host bus interface modes available on the S1D13705 that would be used to interface to the PC Card bus.

The S1D13705 implements a 16-bit interface to the host microprocessor which may operate in one of several modes compatible with most of the popular embedded microprocessor families. The interface mode used for the PC Card bus is:

- Generic #2 (External Chip Select, shared Read/Write Enable for high byte, individual Read/Write Enable for low byte).

Host Bus Pin Connection

The following table shows the functions of the host bus interface signals.

Table 4-1 Host Bus Interface Pin Mapping

S1D13705 Pin Names	Generic #2
AB[15:1]	A[15:1]
AB0	A0
DB[15:0]	D[15:0]
WE1#	BHE#
CS#	External Decode
BCLK	BCLK
BS#	connect to IO V _{DD}
RD/WR#	connect to IO V _{DD}
RD#	RD#
WE0#	WE#
WAIT#	WAIT#
RESET#	RESET#

For details on configuration, refer to the “S1D13705 Hardware Functional Specification”, document number X27A-A-001-02.

Generic #2 Interface Mode

Generic #2 interface mode is a general and non-processor-specific interface mode on the S1D13705. The Generic # 2 interface mode was chosen for this interface due to the simplicity of its timing and compatibility with the PC Card bus control signals.

The interface requires the following signals:

- BUSCLK is a clock input which synchronizes transfers between the host CPU and the S1D13705. It is separate from the input clock (CLKI) and is typically driven by the host CPU system clock.
- The address inputs AB0 through AB16, and the data bus DB0 through DB15, connect directly to the CPU address and data bus, respectively. On 32-bit big endian architectures such as the Power PC, the data bus would connect to the high-order data lines; on little endian hosts, or 16-bit big endian hosts, they would connect to the low-order data lines. The hardware engineer must ensure that CNF3 selects the proper endian mode upon reset.
- Chip Select (CS#) is driven by decoding the high-order address lines to select the proper register and memory address space.
- WE1# is the high byte enable for both read and write cycles.
- WE0# is the write enable for the S1D13705, to be driven low when the host CPU is writing data to the S1D13705.
- RD# is the read enable for the S1D13705, to be driven low when the host CPU is reading data from the S1D13705.

- WAIT# is a signal which is output from the S1D13705 to the host CPU that indicates when data is ready (read cycle) or accepted (write cycle) on the host bus. Since host CPU accesses to the S1D13705 may occur asynchronously to the display update, it is possible that contention may occur in accessing the S1D13705 internal registers and/or refresh memory. The WAIT# line resolves these contentions by forcing the host to wait until the resource arbitration is complete. This signal is active low and may need to be inverted if the host CPU wait state signal is active high.
- The Bus Status (BS#) and Read/Write (RD/WR#) signals are not used in the bus interface for Generic #2 mode. However, BS# is used to configure the S1D13705 for Generic #2 mode and should be tied high (connected to IO V_{DD}). RD/WR# should also be tied high.

4.4 PC Card to S1D13705 Interface

Hardware Connections

The S1D13705 is interfaced to the PC Card bus with a minimal amount of glue logic. In this implementation, the address inputs (AB[16:0]) and data bus (DB[15:0]) connect directly to the CPU address (A[16:0]) and data bus (D[15:0]).

The PC Card interface does not provide a bus clock, so one must be supplied for the S1D13705. Since the bus clock frequency is not critical, nor does it have to be synchronous to the bus signals, it may be the same as CLKI.

BS# (bus start) is not used by Generic #2 mode but is used to configure the S1D13705 for either Generic #1 or Generic #2 bus and should be tied high (connected to IO V_{DD}).

RD/WR# is also not used by Generic #2 bus and should be tied high (connected to IO V_{DD}).

The following diagram shows a typical implementation of the PC Card to S1D13705 interface.

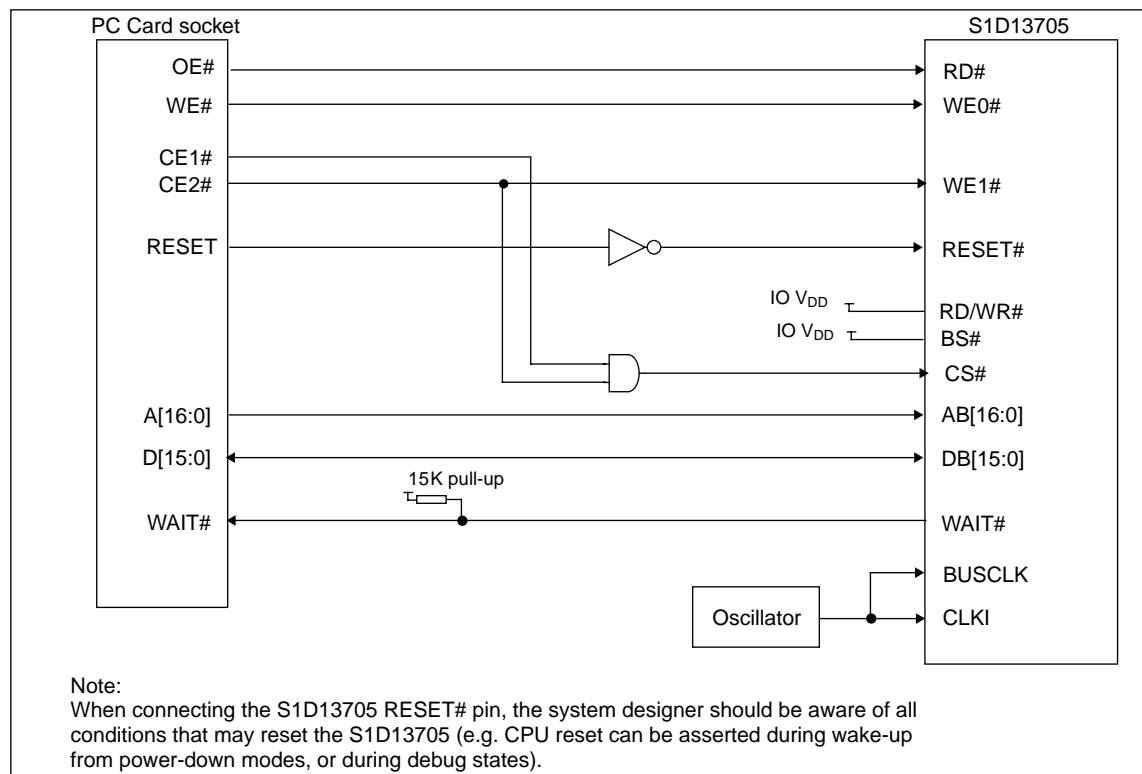

Figure 4-3 Typical Implementation of PC Card to S1D13705 Interface

S1D13705 Hardware Configuration

The S1D13705 uses CNF3 through CNF0 and BS# to allow selection of the bus mode and other configuration data on the rising edge of RESET#. Refer to the “S1D13705 Hardware Functional Specification”, document number X27A-A-001-02 for details.

The tables below show only those configuration settings important to the PC Card host bus interface.

Table 4-2 Summary of Power-On/Reset Options

Signal	Low	High
CNF0	See “Host Bus Interface Selection” table4-3 below.	See “Host Bus Interface Selection” table4-3 below.
CNF1		
CNF2		
CNF3	Little Endian	Big Endian



 = configuration for PC Card host bus interface

Table 4-3 Host Bus Interface Selection

CNF2	CNF1	CNF0	BS#	Host Bus Interface
1	1	1	1	Generic #2, 16-bit

 = configuration for PC Card host bus interface

Register/Memory Mapping

The S1D13705 is a memory mapped device. The S1D13705 memory may be addressed starting at 0000h, or on consecutive 128K byte blocks, and its internal registers are located in the upper 32 bytes of the 128K byte block (i.e. REG[0] = 1FFE0h).

While the PC Card socket provides 64M bytes of memory address space, the S1D13705 only needs a 128K byte block of memory to accommodate its 80K byte display buffer and its 32 byte register set. For this reason only address bits A[16:0] are used while A[25:17] are ignored. Because the entire 64M bytes of memory is available, the S1D13705’s memory and registers will be aliased every 128K bytes for a total of 512 times.

Note: If aliasing is not desirable, the upper addresses must be fully decoded.

4.5 Software

Test utilities and Windows® CE v2.0 display drivers are available for the S1D13705. Full source code is available for both the test utilities and the drivers.

The test utilities are configurable for different panel types using a program called 1375CFG, or by directly modifying the source. The Windows® CE v2.0 display drivers can be customized by the OEM for different panel types, resolutions and color depths only by modifying the source.

5 INTERFACING TO THE TOSHIBA MIPS TMPR3912 MICROPROCESSOR

5.1 Introduction

This application note describes the hardware required to interface the S1D13705 Embedded Memory LCD Controller and the Toshiba MIPS TMPR3912 Processor. The pairing of these two devices results in an embedded system offering impressive display capability with very low power consumption.

5.2 Interfacing to the TMPR3912

The Toshiba MIPS TMPR3912 processor supports up to two PC Card (PCMCIA) slots. It is through this host bus interface that the S1D13705 connects to the TMPR3912 processor.

The S1D13705 can be successfully interfaced using one of two configurations:

Direct connection to TMPR3912.

System design using one ITE IT8368E PC Card/GPIO buffer chip.

5.3 S1D13705 Host Bus Interface

This section is a summary of the host bus interface modes available on the S1D13705 that would be used to interface to the TMPR3912.

The S1D13705 implements a 16-bit interface to the host microprocessor which may operate in one of several modes compatible with most of the popular embedded microprocessor families. The interface modes used for the TMPR3912 are:

- Generic #1 (Chip Select, plus individual Read Enable/Write Enable for each byte).
- Generic #2 (External Chip Select, shared Read/Write Enable for high byte, individual Read/Write Enable for low byte).

Host Bus Pin Connection

The following table shows the functions of each host bus interface signal.

Table 5-1 Host Bus Interface Pin Mapping

S1D13705 Pin Names	Generic #1	Generic #2
AB[15:1]	A[15:1]	A[15:1]
AB0	A0	A0
DB[15:0]	D[15:0]	D[15:0]
WE1#	WE1#	BHE#
CS#	External Decode	External Decode
BCLK	BCLK	BCLK
BS#	connect to V _{SS}	connect to IO V _{DD}
RD/WR#	RD1#	connect to IO V _{DD}
RD#	RD0#	RD#
WE0#	WE0#	WE#
WAIT#	WAIT#	WAIT#
RESET#	RESET#	RESET#

For configuration details, refer to the “S1D13705 Hardware Functional Specification”, document number X27A-A-001-02.

Generic #1 Interface Mode

Generic #1 interface mode is the most general and least processor-specific interface mode on the S1D13705. The Generic # 1 interface mode was chosen for this interface due to the simplicity of its timing.

The interface requires the following signals:

- BUSCLK is a clock input which is required by the S1D13705 host interface. It is separate from the input clock (CLKI) and is typically driven by the host CPU system clock.
- The address inputs AB0 through AB16, and the data bus DB0 through DB15, connect directly to the CPU address and data bus, respectively. On 32-bit big endian architectures such as the Power PC, the data bus would connect to the high-order data lines; on little endian hosts, or 16-bit big endian hosts, they would connect to the low-order data lines. The hardware engineer must ensure that CNF3 selects the proper endian mode upon reset.
- Chip Select (CS#) is driven by decoding the high-order address lines to select the proper register and memory address space.
- WE0# and WE1# are write enables for the low-order and high-order bytes, respectively, to be driven low when the host CPU is writing data to the S1D13705. These signals must be generated by external hardware based on the control outputs from the host CPU.
- RD# and RD/WR# are read enables for the low-order and high-order bytes, respectively, to be driven low when the host CPU is reading data from the S1D13705. These signals must be generated by external hardware based on the control outputs from the host CPU.
- WAIT# is a signal output from the S1D13705 that indicates the host CPU must wait until data is ready (read cycle) or accepted (write cycle) on the host bus. Since host CPU accesses to the S1D13705 may occur asynchronously to the display update, it is possible that contention may occur in accessing the S1D13705 internal registers and/or refresh memory. The WAIT# line resolves these contentions by forcing the host to wait until the resource arbitration is complete. This signal is active low and may need to be inverted if the host CPU wait state signal is active high.
- The Bus Status (BS#) signal is not used in the bus interface for Generic #1 mode. However, BS# is used to configure the S1D13705 for Generic #1 mode and should be tied low (connected to GND).

Generic #2 Interface Mode

Generic #2 interface mode is a general and non-processor-specific interface mode on the S1D13705. The Generic # 2 interface mode was chosen for this interface due to the simplicity of its timing and compatibility with the TMPR3912 control signals.

The interface requires the following signals:

- BUSCLK is a clock input which synchronizes transfers between the host CPU and the S1D13705. It is separate from the input clock (CLKI) and is typically driven by the host CPU system clock.
- The address inputs AB0 through AB16, and the data bus DB0 through DB15, connect directly to the CPU address and data bus, respectively. On 32-bit big endian architectures such as the Power PC, the data bus would connect to the high-order data lines; on little endian hosts, or 16-bit big endian hosts, they would connect to the low-order data lines. The hardware engineer must ensure that CNF3 selects the proper endian mode upon reset.
- Chip Select (CS#) is driven by decoding the high-order address lines to select the proper register and memory address space.
- WE1# is the high byte enable for both read and write cycles for the S1D13705, to be driven low when the host CPU accesses the S1D13705.
- WE0# is the write enable for the S1D13705, to be driven low when the host CPU is reading data from the S1D13705.
- RD# is the read enable for the S1D13705, to be driven low when the host CPU is reading data from the S1D13705.
- WAIT# is a signal which is output from the S1D13705 to the host CPU that indicates when data is ready (read cycle) or accepted (write cycle) on the host bus. Since host CPU accesses to the S1D13705 may occur asynchronously to the display update, it is possible that contention may occur in accessing the 13705 internal registers and/or refresh memory. The WAIT# line resolves these contentions by forcing the host to wait until the resource arbitration is complete. This signal is active low and may need to be inverted if the host CPU wait state signal is active high.
- The Bus Status (BS#) and Read/Write (RD/WR#) signals are not used in the bus interface for Generic #2 mode. However, BS# is used to configure the S1D13705 for Generic #2 mode and should be tied high (connected to IO V_{DD}). RD/WR# should also be tied high.

5.4 Direct Connection to the Toshiba TMPR3912

General Description

In this example implementation, the S1D13705 occupies the TMPR3912 PC Card slot #1.

The S1D13705 is easily interfaced to the TMPR3912 with minimal additional logic. The address bus of the TMPR3912 PC Card interface is multiplexed and must be demultiplexed using an advanced CMOS latch (e.g., 74AHC373). The direct connection approach makes use of the S1D13705 in its “Generic Interface #2” configuration.

The following diagram demonstrates a typical implementation of the interface.

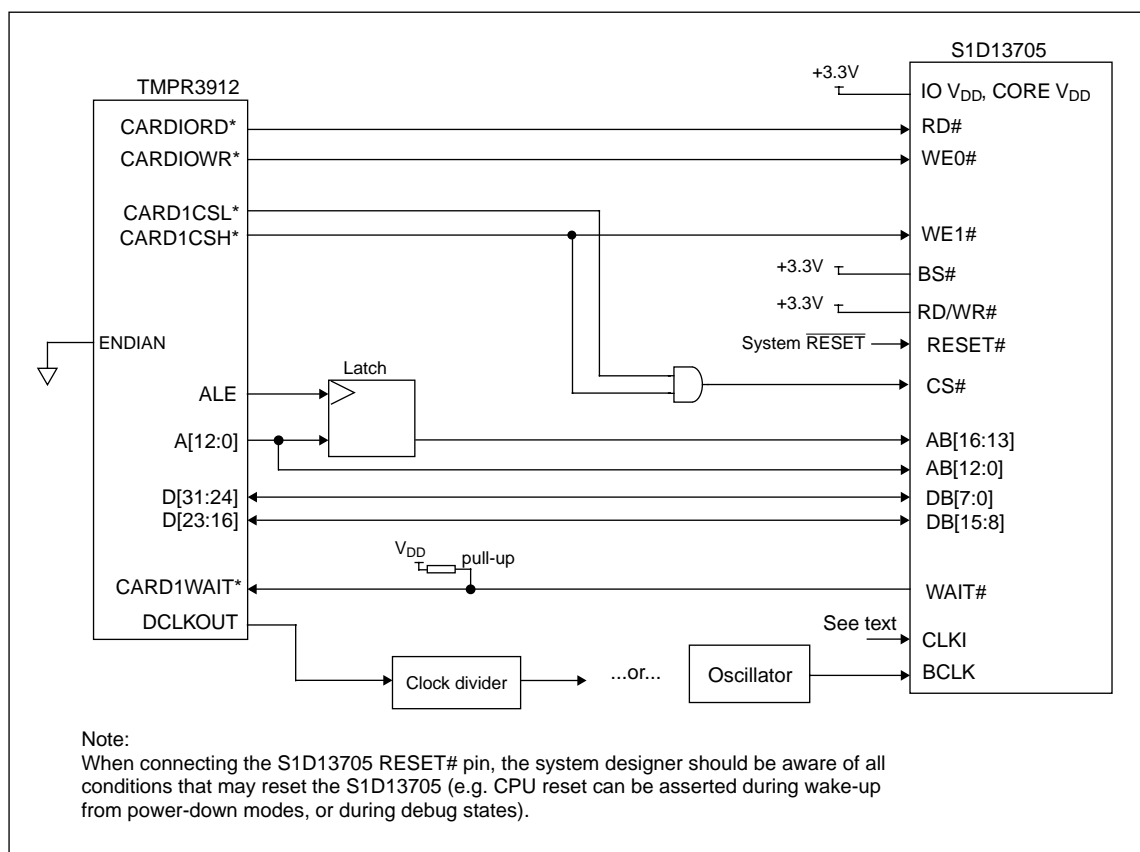

Figure 5-1 S1D13705 to TMPR3912 Direct Connection

Note: See Section , “Host Bus Pin Connection” on page 5-29 and Section , “Generic #2 Interface Mode” on page 5-26 for Generic #2 pin descriptions.

The “Generic #2” host interface control signals of the S1D13705 are asynchronous with respect to the S1D13705 bus clock. This gives the system designer full flexibility to choose the appropriate source (or sources) for CLKI and BCLK. The choice of whether both clocks should be the same, and whether to use DCLKOUT (divided) as clock source, should be based on the desired:

- pixel and frame rates.
- power budget.
- part count.
- maximum S1D13705 clock frequencies.

The S1D13705 also has internal clock dividers providing additional flexibility.

Memory Mapping and Aliasing

In this example implementation the TMPR3912 control signal CARDREG* is ignored; therefore the S1D13705 takes up the entire PC Card slot 1.

The S1D13705 requires an addressing space of 128K bytes. The on-chip display memory occupies the range 0 through 13FFFh. The registers occupy the range 1FFE0h through 1FFFFh. The TMPR3912 demultiplexed address lines A17 and above are ignored, thus the S1D13705 is aliased 512 times at 128K byte intervals over the 64M byte PC Card slot #1 memory space.

Note: If aliasing is undesirable, additional decoding circuitry must be added.

S1D13705 Configuration

The S1D13705 is configured at power up by latching the state of the CNF[3:0] pins. Pin BS# also plays a role in host bus interface configuration. For details on configuration, refer to the “*S1D13705 Hardware Functional Specification*”, document number X27A-A-001-02.

The table below shows those configuration settings relevant to the direct connection approach.

Table 5-2 S1D13705 Configuration for Direct Connection

S1D13705 Configuration Pin	Value hard wired on this pin is used to configure:	
	1 (IO V _{DD})	0 (V _{SS})
BS#	Generic #2	Generic #1
CNF3	Big Endian	Little Endian
CNF[2:0]	111: Generic #1 or #2	

 = configuration for Toshiba TMPR3912 host bus interface

5.5 Using the ITE IT8368E PC Card Buffer

If the system designer uses the ITE IT8368E PC Card and multiple-function I/O buffer, the S1D13705 can be interfaced so that it “shares” a PC Card slot. The S1D13705 is mapped to a rarely-used 16M byte portion of the PC Card slot buffered by the IT8368E, making the S1D13705 virtually transparent to PC Card devices that use the same slot.

Hardware Description

The ITE8368E has been specially designed to support EPSON LCD controllers and provides eleven Multi-Function IO pins (MFIO). Configuration registers may be used to allow these MFIO pins to provide the control signals required to implement the S1D13705 CPU interface.

The TMPR3912 processor only provides addresses A[12:0], therefore devices requiring more address space must use an external device to latch A[25:13]. The IT8368E’s MFIO pins can be configured to provide this latched address.

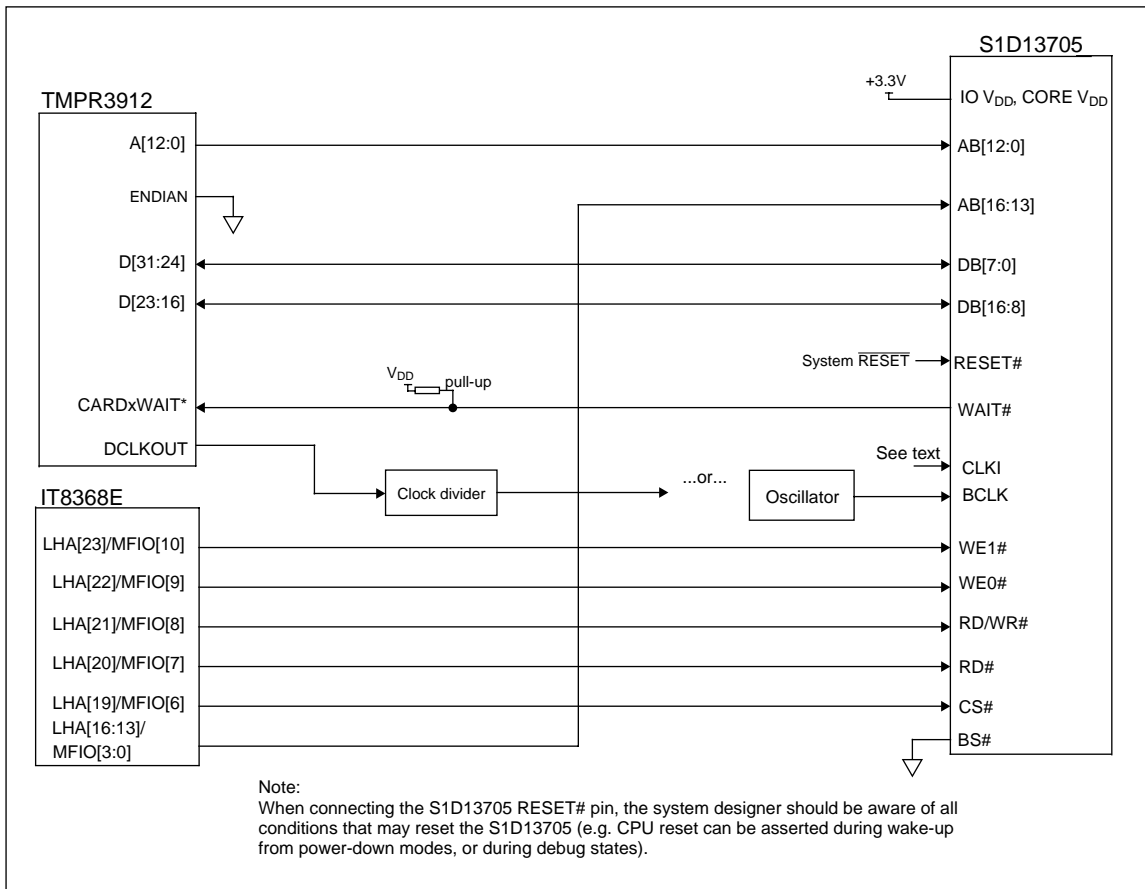

Figure 5-2 S1D13705 to TMPR3912 Connection Using an IT8368E

Note: See Section , “Host Bus Pin Connection” on page 5-29 and Section , “Generic #1 Interface Mode” on page 5-30 for Generic #1 pin descriptions.

The “Generic #1” host interface control signals of the S1D13705 are asynchronous with respect to the S1D13705 bus clock. This gives the system designer full flexibility to choose the appropriate source (or sources) for CLKI and BCLK. The choice of whether both clocks should be the same, and whether to use DCLKOUT (divided) as clock source, should be based on pixel and frame rates, power budget, part count and maximum S1D13705 respective clock frequencies. Also, internal S1D13705 clock dividers provide additional flexibility.

IT8368E Configuration

The IT8368E provides eleven multi-function IO pins (MFIO). The IT8368E must have both “Fix Attribute/IO” and “VGA” modes on. When both these modes are enabled, the MFIO pins provide control signals needed by the S1D13705 host bus interface, and a 16M byte portion of the system PC Card attribute and IO space is allocated to address the S1D13705. When accessing the S1D13705 the associated card-side signals are disabled in order to avoid any conflicts.

For mapping details, refer to section 3.3: “Memory Mapping and Aliasing.” For connection details see Figure 5-2, “S1D13705 to TMPR3912 Connection Using an IT8368E,” above. For further information on the IT8368E, refer to the “IT8368E PC Card/GPIO Buffer Chip Specification”.

Note: When a second IT8368E is used, that circuit should not be set in VGA mode.

Memory Mapping and Aliasing

When the TMPR3912 accesses the PC Card slots *without* the ITE IT8368E, its system memory is mapped as in Table 5-3 .

Note: Bit CARD1IOEN or CARD2IOEN, depending on which card slot is used, must be set to 0 in the TMPR3912 Memory Configuration Register 3.

When the TMPR3912 accesses the PC Card slots buffered through the ITE IT8368E, bits CARD1IOEN and CARD2IOEN are ignored and the attribute/IO space of the TMPR3912 is divided into Attribute, I/O and S1D13705 access. Details of the Attribute/IO address reallocation by the IT8368E are found in Table 5-3 .

Table 5-3 TMPR3912 to PC Card Slots Address Mapping With and Without the IT8368E

PC Card Slot #	TMPR3912 Address	Size	Using the ITE IT8368E	Direct Connection, CARDnIOEN=0	Direct Connection, CARDnIOEN=1
1	0800 0000h	16M byte	Card 1 IO	S1D13705 (aliased 512 times at 128K byte intervals)	Card 1 IO
	0900 0000h	16M byte	S1D13705 (aliased 128 times at 128K byte intervals)		
	0A00 0000h	32M byte	Card 1 Attribute		
	6400 0000h	64M byte	Card 1 Memory		
2	0C00 0000h	16M byte	Card 2 IO	S1D13705 (aliased 512 times at 128K byte intervals)	Card 2 IO
	0D00 0000h	16M byte	S1D13705 (aliased 128 times at 128K byte intervals)		
	0E00 0000h	32M byte	Card 2 Attribute		
	6800 0000h	64M byte	Card 2 Memory		

S1D13705 Configuration

The S1D13705 is configured at power up by latching the state of the CNF[3:0] pins. Pin BS# also plays a role in host bus interface configuration. For details on configuration, refer to the “*S1D13705 Hardware Functional Specification*”, document number X26A-A-001-02.

The table below shows those configuration settings relevant to this specific interface.

Table 5-4 S1D13705 Configuration Using the IT8368E

S1D13705 Configuration Pin	Value hard wired on this pin is used to configure:	
		1 (IO V _{DD})
BS#	Generic #2	Generic #1
CNF3	Big Endian	Little Endian
CNF[2:0]	111: Generic #1 or #2	

 = configuration for connection using ITE IT8368E

5.6 Software

Test utilities and Windows® CE v2.0 display drivers are available for the S1D13705. Full source code is available for both the test utilities and the drivers.

The test utilities are configurable for different panel types using a program called 1375CFG, or by directly modifying the source. The Windows® CE v2.0 display drivers can be customized by the OEM for different panel types, resolutions and color depths only by modifying the source.

6 *INTERFACING TO THE PHILIPS MIPS PR31500/PR31700 PROCESSOR*

6.1 *Introduction*

This application note describes the hardware required to interface the S1D13705 Embedded Memory LCD Controller and the Philips MIPS PR31500/PR31700 Processor. The pairing of these two devices results in an embedded system offering impressive display capability with very low power consumption.

6.2 *Interfacing to the PR31500/PR31700*

The Philips MIPS PR31500/PR31700 processor supports up to two PC Card (PCMCIA) slots. It is through this host bus interface that the S1D13705 connects to the PR31500/PR31700 processor.

The S1D13705 can be successfully interfaced using one of two configurations:

- Direct connection to PR31500/PR31700 (see Section 5.4, “*Direct Connection to the Toshiba Tmpr3912*” on page 5-31).
- System design using one ITE IT8368E PC Card/GPIO buffer chip (see Section 5.5, “*Using the ITE IT8368E PC Card Buffer*” on page 5-33).

6.3 *S1D13705 Host Bus Interface*

This section is a summary of the host bus interface modes available on the S1D13705 that would be used to interface to the PR31500/PR31700.

The S1D13705 implements a 16-bit interface to the host microprocessor which may operate in one of several modes compatible with most of the popular embedded microprocessor families. The interface modes used for the PR31500/PR31700 are:

- Generic #1 (Chip Select, plus individual Read Enable/Write Enable for each byte).
- Generic #2 (External Chip Select, shared Read/Write Enable for high byte, individual Read/Write Enable for low byte).

Host Bus Pin Connection

The following table shows the functions of each host bus interface signal.

Table 6-1 Host Bus Interface Pin Mapping

S1D13705 Pin Names	Generic #1	Generic #2
AB[15:1]	A[15:1]	A[15:1]
AB0	A0	A0
DB[15:0]	D[15:0]	D[15:0]
WE1#	WE1#	BHE#
CS#	External Decode	External Decode
BCLK	BCLK	BCLK
BS#	connect to V _{SS}	connect to IO V _{DD}
RD/WR#	RD1#	connect to IO V _{DD}
RD#	RD0#	RD#
WE0#	WE0#	WE#
WAIT#	WAIT#	WAIT#
RESET#	RESET#	RESET#

For details on configuration, refer to the “*S1D13705 Hardware Functional Specification*”, document number X27A-A-001-02.

Generic #1 Interface Mode

Generic #1 interface mode is the most general and least processor-specific interface mode on the S1D13705. The Generic # 1 interface mode was chosen for this interface due to the simplicity of its timing.

The interface requires the following signals:

- BUSCLK is a clock input which is required by the S1D13705 host interface. It is separate from the input clock (CLKI) and is typically driven by the host CPU system clock.
- The address inputs AB0 through AB16, and the data bus DB0 through DB15, connect directly to the CPU address and data bus, respectively. On 32-bit big endian architectures such as the Power PC, the data bus would connect to the high-order data lines; on little endian hosts, or 16-bit big endian hosts, they would connect to the low-order data lines. The hardware engineer must ensure that CNF3 selects the proper endian mode upon reset.
- Chip Select (CS#) is driven by decoding the high-order address lines to select the proper register and memory address space.
- WE0# and WE1# are write enables for the low-order and high-order bytes, respectively, to be driven low when the host CPU is writing data to the S1D13705. These signals must be generated by external hardware based on the control outputs from the host CPU.
- RD# and RD/WR# are read enables for the low-order and high-order bytes, respectively, to be driven low when the host CPU is reading data from the S1D13705. These signals must be generated by external hardware based on the control outputs from the host CPU.
- WAIT# is a signal output from the S1D13705 that indicates the host CPU must wait until data is ready (read cycle) or accepted (write cycle) on the host bus. Since host CPU accesses to the S1D13705 may occur asynchronously to the display update, it is possible that contention may occur in accessing the S1D13705 internal registers and/or refresh memory. The WAIT# line resolves these contentions by forcing the host to wait until the resource arbitration is complete. This signal is active low and may need to be inverted if the host CPU wait state signal is active high.
- The Bus Status (BS#) signal is not used in the bus interface for Generic #1 mode. However, BS# is used to configure the S1D13705 for Generic #1 mode and should be tied low (connected to GND).

Generic #2 Interface Mode

Generic #2 interface mode is a general and non-processor-specific interface mode on the S1D13705. The Generic # 2 interface mode was chosen for this interface due to the simplicity of its timing and compatibility with the PR31500/PR31700 control signals.

The interface requires the following signals:

- BUSCLK is a clock input which synchronizes transfers between the host CPU and the S1D13705. It is separate from the input clock (CLKI) and is typically driven by the host CPU system clock.
- The address inputs AB0 through AB16, and the data bus DB0 through DB15, connect directly to the CPU address and data bus, respectively. On 32-bit big endian architectures such as the Power PC, the data bus would connect to the high-order data lines; on little endian hosts, or 16-bit big endian hosts, they would connect to the low-order data lines. The hardware engineer must ensure that CNF3 selects the proper endian mode upon reset.
- Chip Select (CS#) is driven by decoding the high-order address lines to select the proper register and memory address space.
- WE1# is the high byte enable for both read and write cycles.
- WE0# is the write enable signal for the S1D13705, to be driven low when the host CPU is writing data from the S1D13705.
- RD# is the read enable for the S1D13705, to be driven low when the host CPU is reading data from the S1D13705.
- WAIT# is a signal which is output from the S1D13705 to the host CPU that indicates when data is ready (read cycle) or accepted (write cycle) on the host bus. Since host CPU accesses to the S1D13705 may occur asynchronously to the display update, it is possible that contention may occur in accessing the 13705 internal registers and/or refresh memory. The WAIT# line resolves these contentions by forcing the host to wait until the resource arbitration is complete. This signal is active low and may need to be inverted if the host CPU wait state signal is active high.
- The Bus Status (BS#) and Read/Write (RD/WR#) signals are not used in the bus interface for Generic #2 mode. However, BS# is used to configure the S1D13705 for Generic #2 mode and should be tied high (connected to IO V_{DD}). RD/WR# should also be tied high.

6.4 Direct Connection to the Philips PR31500/PR31700

General Description

In this example implementation the S1D13705 occupies the PR31500/PR31700 PC Card slot #1.

The S1D13705 is easily interfaced to the PR31500/PR31700 with minimal additional logic. The address bus of the PR31500/PR31700 PC Card interface is multiplexed and must be demultiplexed using an advanced CMOS latch (e.g., 74AHC373). The direct connection approach makes use of the S1D13705 in its “Generic #2” interface configuration.

The following diagram demonstrates a typical implementation of the interface.

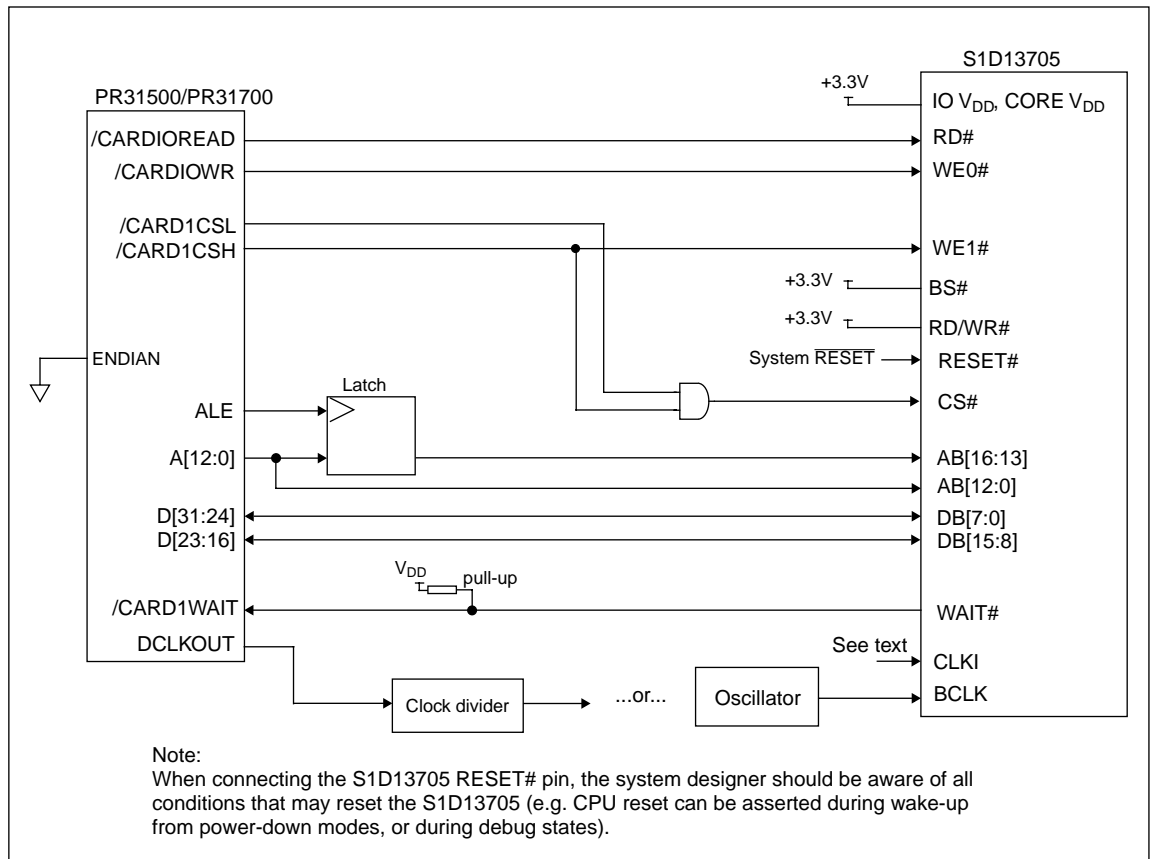

Figure 6-1 S1D13705 to PR31500/PR31700 Direct Connection

Note: See Section , “Host Bus Pin Connection” on page 5-29 and Section , “Generic #2 Interface Mode” on page 5-26 for Generic #2 pin descriptions.

The “Generic #2” host interface control signals of the S1D13705 are asynchronous with respect to the S1D13705 bus clock. This gives the system designer full flexibility to choose the appropriate source (or sources) for CLKI and BCLK. The choice of whether both clocks should be the same, and whether to use DCLKOUT (divided) as clock source, should be based on the desired:

- pixel and frame rates.
- power budget.
- part count.
- maximum S1D13705 clock frequencies.

The S1D13705 also has internal clock dividers providing additional flexibility.

Memory Mapping and Aliasing

The S1D13705 requires an addressing space of 128K bytes. The on-chip display memory occupies the range 0 through 13FFFh. The registers occupy the range 1FFE0h through 1FFFFh. The PR31500/PR31700 demultiplexed address lines A17 and above are ignored, thus the S1D13705 is aliased 512 times at 128K byte intervals over the 64M byte PC Card slot #1 memory space. In this example implementation, the PR31500/PR31700 control signal /CARDREG is ignored; therefore the S1D13705 also takes up the entire PC Card slot 1 configuration space.

Note: If aliasing is undesirable, additional decoding circuitry must be added.

S1D13705 Configuration and Pin Mapping

The S1D13705 is configured at power up by latching the state of the CNF[3:0] pins. Pin BS# also plays a role in host bus interface configuration. For details on configuration, refer to the “*S1D13705 Hardware Functional Specification*”, document number X27A-A-001-02.

The table below shows those configuration settings relevant to the direct connection approach.

Table 6-2 S1D13705 Configuration for Direct Connection

S1D13705 Configuration Pin	Value hard wired on this pin is used to configure:	
	1 (IO V _{DD})	0 (V _{SS})
BS#	Generic #2	Generic #1
CNF3	Big Endian	Little Endian
CNF[2:0]	111: Generic #1 or #2	

 = configuration for Philips PR31500/PR31700 host bus interface

6.5 Using the ITE IT8368E PC Card Buffer

If the system designer uses the ITE IT8368E PC Card and multiple-function I/O buffer, the S1D13705 can be interfaced so that it “shares” a PC Card slot. The S1D13705 is mapped to a rarely-used 16M byte portion of the PC Card slot buffered by the IT8368E. This makes the S1D13705 virtually transparent to PC Card devices that use the same slot.

Hardware Description

The ITE8368E has been specially designed to support EPSON LCD controllers. The ITE IT8368E provides eleven Multi-Function IO pins (MFIO). Configuration registers may be used to allow these MFIO pins to provide the control signals required to implement the S1D13705 CPU interface.

The PR31500/PR31700 processor only provides addresses A[12:0]; therefore devices requiring more address space must use an external device to latch A[25:13]. The IT8368E’s MFIO pins can be configured to provide this latched address.

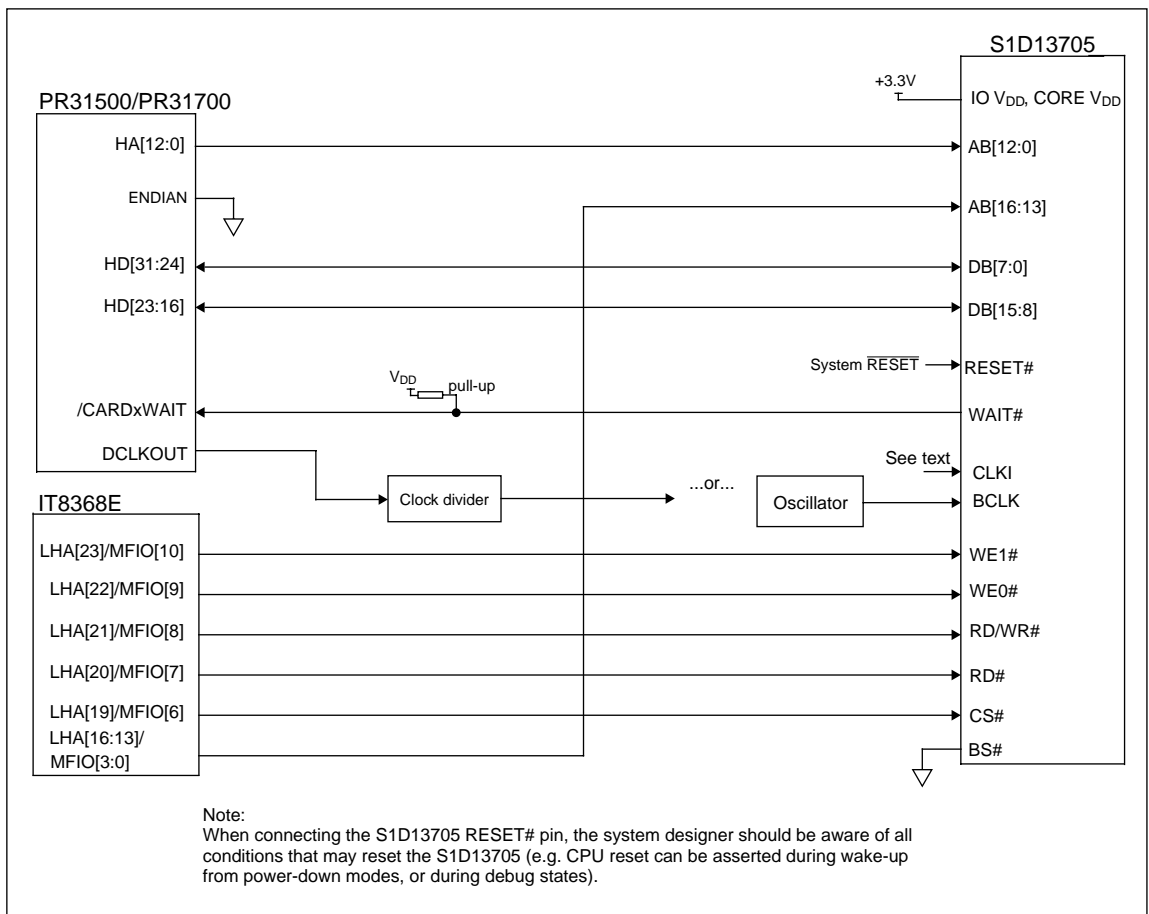

Figure 6-2 S1D13705 to PR31500/PR31700 Connection Using an IT8368E

Note: See Section on page 29 and Section on page 30 for Generic #1 pin descriptions.

The “Generic #1” host interface control signals of the S1D13705 are asynchronous with respect to the S1D13705 bus clock. This gives the system designer full flexibility to choose the appropriate source (or sources) for CLKI and BCLK. The choice of whether both clocks should be the same, and whether to use DCLKOUT (divided) as clock source, should be based on the desired:

- pixel and frame rates.
- power budget.
- part count.
- maximum S1D13705 clock frequencies.

The S1D13705 also has internal clock dividers providing additional flexibility.

IT8368E Configuration

The IT8368E provides eleven multi-function IO pins (MFIO). The IT8368E must have both “Fix Attribute/IO” and “VGA” modes on. When both these modes are enabled, the MFIO pins provide control signals needed by the S1D13705 host bus interface, and a 16M byte portion of the system PC Card attribute and IO space is allocated to address the S1D13705. When accessing the S1D13705 the associated card-side signals are disabled in order to avoid any conflicts.

For mapping details, refer to section 3.3: “*Memory Mapping and Aliasing.*” For connection details see Figure 5-2, “*S1D13705 to TMPR3912 Connection Using an IT8368E,*” on page 5-34. For further information on the IT8368E, refer to the “*IT8368E PC Card/GPIO Buffer Chip Specification*”.

Note: When a second IT8368E is used, that circuit should not be set in VGA mode.

Memory Mapping and Aliasing

When the PR31500/PR31700 accesses the PC Card slots *without* the ITE IT8368E, its system memory is mapped as in Table 6-3 .

Note: Bit CARD1IOEN or CARD2IOEN, depending on which card slot is used, must to be set to 0 in the PR31500/PR31700 Memory Configuration Register 3.

When the PR31500/PR31700 accesses the PC Card slots buffered through the ITE IT8368E, bits CARD1IOEN and CARD2IOEN are ignored and the attribute/IO space of the PR31500/PR31700 is divided into Attribute, I/O and S1D13705 access. Table 6-3 provides all details of the Attribute/IO address reallocation by the IT8368E.

Table 6-3 PR31500/PR31700 to PC Card Slots Address Mapping With and Without the IT8368E

PC Card Slot #	TX3912 Address	Size	Using the ITE IT8368E	Direct Connection, CARDnIOEN=0	Direct Connection, CARDnIOEN=1
1	0800 0000h	16M byte	Card 1 IO	S1D13705 (aliased 512 times at 128K byte intervals)	Card 1 IO
	0900 0000h	16M byte	S1D13705 (aliased 128 times at 128K byte intervals)		
	0A00 0000h	32M byte	Card 1 Attribute	S1D13705 (aliased 512 times at 128K byte intervals)	
	6400 0000h	64M byte	Card 1 Memory		
2	0C00 0000h	16M byte	Card 2 IO	S1D13705 (aliased 512 times at 128K byte intervals)	Card 2 IO
	0D00 0000h	16M byte	S1D13705 (aliased 128 times at 128K byte intervals)		
	0E00 0000h	32M byte	Card 2 Attribute	S1D13705 (aliased 512 times at 128K byte intervals)	
	6800 0000h	64M byte	Card 2 Memory		

S1D13705 Configuration

The S1D13705 is configured at power up by latching the state of the CNF[3:0] pins. Pin BS# also plays a role in host bus interface configuration. For details on configuration, refer to the “*S1D13705 Hardware Functional Specification*”, document number X27A-A-001-02.

The table below shows those configuration settings relevant to this specific interface.

Table 6-4 S1D13705 Configuration Using the IT8368E

S1D13705 Configuration Pin	Value hard wired on this pin is used to configure:	
	1 (IO V _{DD})	0 (V _{SS})
BS#	Generic #2	Generic #1
CNF3	Big Endian	Little Endian
CNF[2:0]	111: Generic #1 or #2	

= configuration for connection using ITE IT8368E

6.6 *Software*

Test utilities and Windows® CE v2.0 display drivers are available for the S1D13705. Full source code is available for both the test utilities and the drivers.

The test utilities are configurable for different panel types using a program called 1375CFG, or by directly modifying the source. The Windows® CE v2.0 display drivers can be customized by the OEM for different panel types, resolutions and color depths only by modifying the source.

7 INTERFACING TO THE NEC VR4102/ VR4111 MICROPROCESSOR

7.1 Introduction

This application note describes the hardware required to interface the S1D13705 Embedded Memory LCD Controller and the NEC VR4102/VR4111 Microprocessor (μ PD30102). The NEC VR4102/VR4111 Microprocessor is specifically designed to support an external LCD controller and the pairing of these two devices results in an embedded system offering impressive display capability with very low power consumption.

7.2 Interfacing to the NEC VR4102/VR4111

The NEC VR4102/VR4111 System Bus

The VR-Series family of microprocessors features a high-speed synchronous system bus typical of modern microprocessors. Designed with external LCD controller support and Windows CE-based embedded consumer applications in mind, the VR4102/VR4111 offers a highly integrated solution for portable systems. This section is an overview of the operation of the CPU bus to establish interface requirements.

Overview

The NEC VR4102/VR4111 is designed around the RISC architecture developed by MIPS. This microprocessor is designed around the 66MHz VR4100 CPU core which supports 64-bit processing. The CPU communicates with the Bus Control Unit (BCU) with its internal SysAD bus. The BCU in turn communicates with external devices with its ADD and DAT buses that can be dynamically sized to 16 or 32-bit operation.

The NEC VR4102/VR4111 has direct support for an external LCD controller. Specific control signals are assigned for an external LCD controller that provide an easy interface to the CPU. A 16M byte block of memory is assigned for the LCD controller with its own chip select and ready signals available. Word or byte accesses are controlled by the system high byte signal, SHB#.

LCD Memory Access Cycles

Once an address in the LCD block of memory is placed on the external address bus, ADD[25:0], the LCD chip select, LCDCS#, is driven low. The read or write enable signals, RD# and WR#, are driven low for the appropriate cycle. LCDRDY is driven low by the S1D13705 to insert wait states into the cycle. The high byte enable is driven low for 16-bit transfers and high for 8-bit transfers.

Figure 7-1, “NEC VR4102/VR4111 Read/Write Cycles,” below, shows the read and write cycles to the LCD Controller Interface.

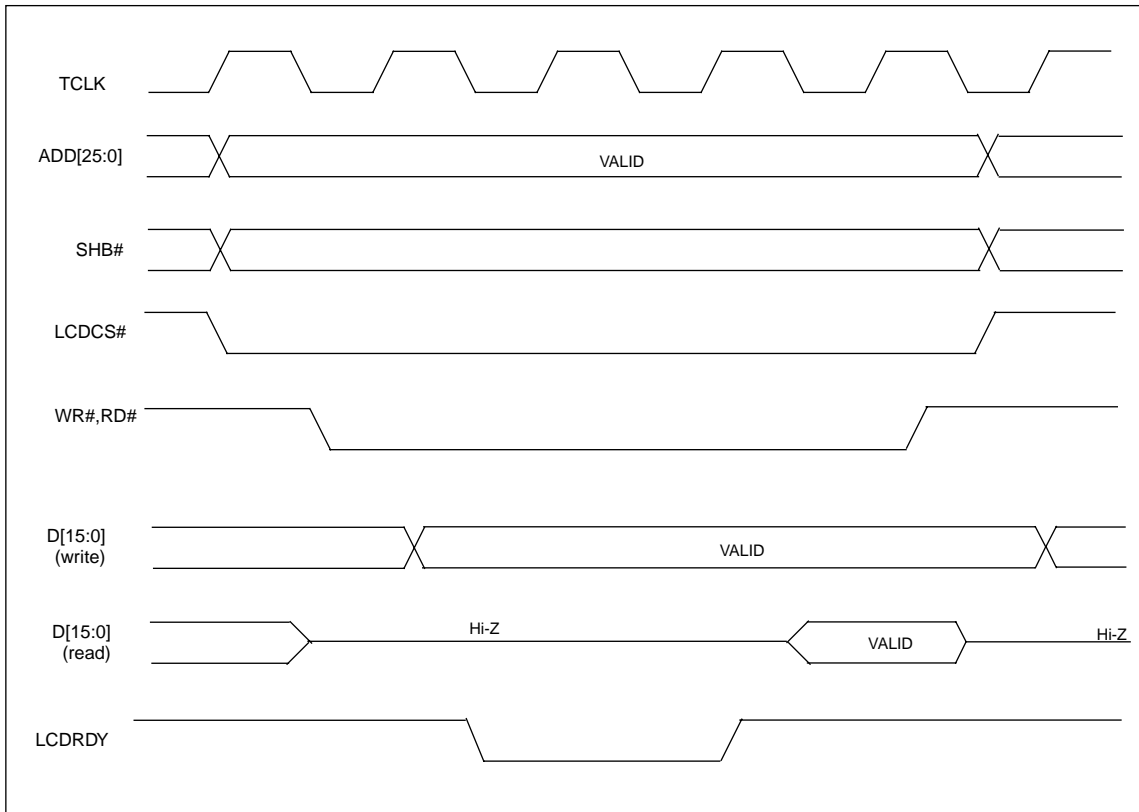

Figure 7-1 NEC VR4102/VR4111 Read/Write Cycles

7.3 S1D13705 Host Bus Interface

This section is a summary of the host bus interface modes available on the S1D13705 that would be used to interface to the VR4102/VR4111.

The S1D13705 implements a 16-bit interface to the host microprocessor which may operate in one of several modes compatible with most of the popular embedded microprocessor families. The interface mode used for the VR4102/VR4111 is:

- Generic #2 (External Chip Select, shared Read/Write Enable for high byte, individual Read/Write Enable for low byte).

Host Bus Pin Connection

The following table shows the functions of each host bus interface signal.

Table 7-1 Host Bus Interface Pin Mapping

S1D13705 Pin Names	Generic #2
AB[15:1]	A[15:1]
AB0	A0
DB[15:0]	D[15:0]
WE1#	BHE#
CS#	External Decode
BCLK	BCLK
BS#	connect to IO V _{DD}
RD/WR#	connect to IO V _{DD}
RD#	RD#
WE0#	WE#
WAIT#	WAIT#
RESET#	RESET#

For details on configuration, refer to the “S1D13705 Hardware Functional Specification”, document number X27A-A-001-02.

Generic #2 Interface Mode

Generic #2 interface mode is a general and non-processor-specific interface mode on the S1D13705. The Generic # 2 interface mode was chosen for this interface due to the simplicity of its timing and compatibility with the VR4102/VR4111 control signals.

The interface requires the following signals:

- BUSCLK is a clock input which synchronizes transfers between the host CPU and the S1D13705. It is separate from the input clock (CLKI) and is typically driven by the host CPU system clock.
- The address inputs AB0 through AB16, and the data bus DB0 through DB15, connect directly to the CPU address and data bus, respectively. On 32-bit big endian architectures such as the Power PC, the data bus would connect to the high-order data lines; on little endian hosts, or 16-bit big endian hosts, they would connect to the low-order data lines. The hardware engineer must ensure that CNF3 selects the proper endian mode upon reset.
- Chip Select (CS#) is driven by decoding the high-order address lines to select the proper register and memory address space.
- WE1# is the high byte enable for both read and write cycles.
- WE0# is the write enable for the S1D13705, to be driven low when the host CPU is writing data to the S1D13705.
- RD# is the read enable for the S1D13705, to be driven low when the host CPU is reading data from the S1D13705.

- WAIT# is a signal which is output from the S1D13705 to the host CPU that indicates when data is ready (read cycle) or accepted (write cycle) on the host bus. Since host CPU accesses to the S1D13705 may occur asynchronously to the display update, it is possible that contention may occur in accessing the S1D13705 internal registers and/or refresh memory. The WAIT# line resolves these contentions by forcing the host to wait until the resource arbitration is complete. This signal is active low and may need to be inverted if the host CPU wait state signal is active high.
- The Bus Status (BS#) and Read/Write (RD/WR#) signals are not used in the bus interface for Generic #2 mode. However, BS# is used to configure the S1D13705 for Generic #2 mode and should be tied high (connected to IO V_{DD}). RD/WR# should also be tied high.

7.4 VR4102/VR4111 to S1D13705 Interface

Hardware Description

The NEC VR4102/VR4111 Microprocessor is specifically designed to support an external LCD controller by providing the internal address decoding and control signals necessary. By using the Generic # 2 interface, no glue logic is required to interface the S1D13705 and the NEC VR4102/VR4111. A pull-up resistor is attached to WAIT# to speed up its rise time when terminating a cycle.

The following diagram shows a typical implementation of the VR4102/VR4111 to S1D13705 interface.

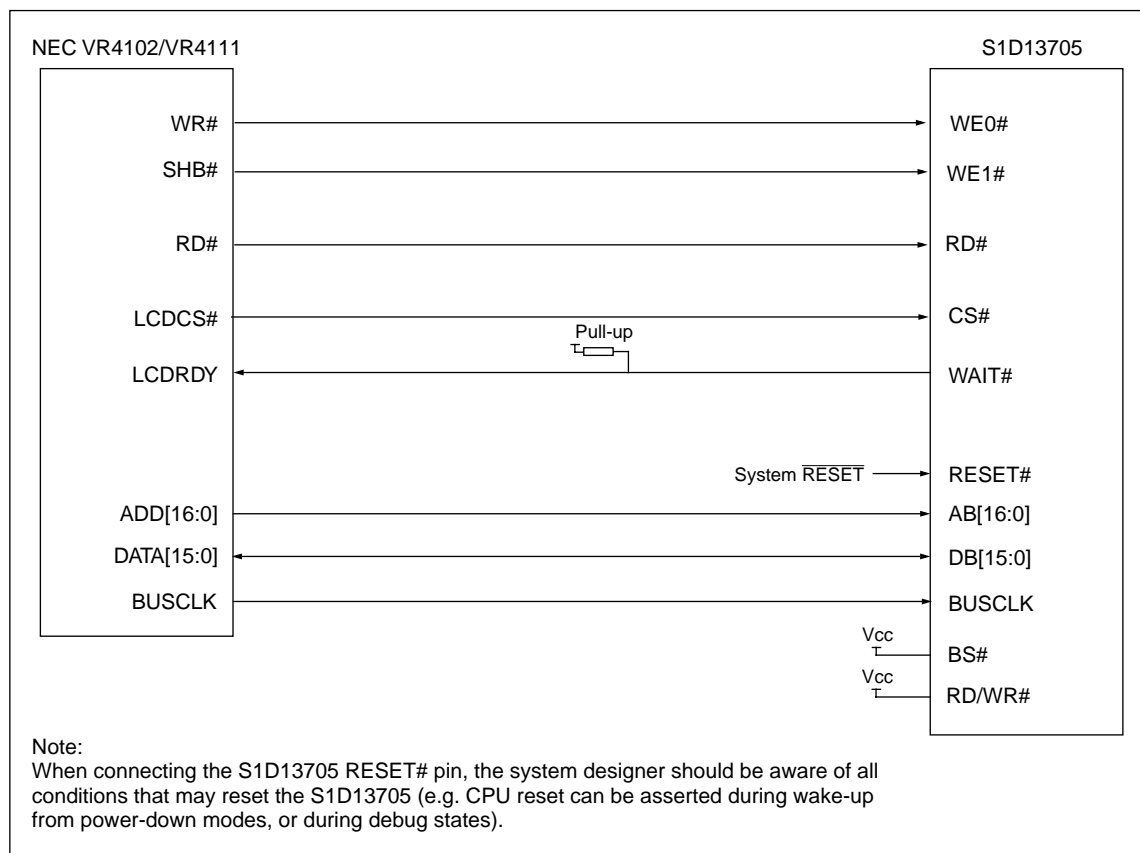

Figure 7-2 Typical Implementation of VR4102/VR4111 to S1D13705 Interface

S1D13705 Hardware Configuration

The S1D13705 uses CNF3 through CNF0 and BS# to allow selection of the bus mode and other configuration data on the rising edge of RESET#. Refer to the “*S1D13705 Hardware Functional Specification*”, document number X27A-A-001-02 for details.

The tables below show those configuration settings important to the Generic #2 host bus interface.

Table 7-2 Summary of Power-On/Reset Options

Signal	value on this pin at the rising edge of RESET# is used to configure: (0/1)	
	0	1
CNF0	See “Host Bus Interface Selection” table7-3 below.	See “Host Bus Interface Selection” table7-3 below.
CNF1		
CNF2		
CNF3	Little Endian	Big Endian

 = configuration for NEC VR4102/VR4111 support

Table 7-3 Host Bus Interface Selection

CNF2	CNF1	CNF0	BS#	Host Bus Interface
1	1	1	1	Generic #2, 16-bit

 = configuration for NEC VR4102/VR4111 support

NEC VR4102/VR4111 Configuration

The NEC VR4102/VR4111 provides the internal address decoding necessary to map to an external LCD controller. Physical address 0A000000h to 0AFFFFFFh (16M bytes) is reserved for an external LCD controller.

The S1D13705 supports up to 80K bytes of display buffer memory and 32 bytes for internal registers. Therefore, the S1D13705 will be shadowed over the entire 16M byte memory range at 128K byte segments. The starting address of the display buffer is 0A000000h and register 0 of the S1D13705 (REG[00h]) resides at 0A01FFE0h.

The NEC VR4102/VR4111 has a 16-bit internal register named BCUCNTREG2 located at address 0B000002h. It must be set to the value of 0001h to indicate that LCD controller accesses use a non-inverting data bus.

The 16-bit internal register named BCUCNTREG1, located at address 0B000000h, must have bit D[13] (ISA/LCD bit) set to 0 to reserve the 16M bytes space, 0A000000h to 0AFFFFFFh, for LCD use and not as ISA bus memory space.

7.5 Software

Test utilities and Windows® CE v2.0 display drivers are available for the S1D13705. Full source code is available for both the test utilities and the drivers.

The test utilities are configurable for different panel types using a program called 1375CFG, or by directly modifying the source. The Windows® CE v2.0 display drivers can be customized by the OEM for different panel types, resolutions and color depths only by modifying the source.

8 *INTERFACING TO THE NEC VR4181A™ MICROPROCESSOR*

8.1 *Introduction*

This application note describes the hardware required to interface the S1D13705 Embedded Memory LCD Controller and the NEC VR4181A microprocessor. The NEC VR4181A microprocessor is specifically designed to support an external LCD controller and the pairing of these two devices results in an embedded system offering impressive display capability with very low power consumption.

8.2 *Interfacing to the NEC VR4181A*

The NEC VR4181A System Bus

The VR-Series family of microprocessors features a high-speed synchronous system bus typical of modern microprocessors. Designed with external LCD controller support and Windows CE based embedded consumer applications in mind, the VR4181A offers a highly integrated solution for portable systems. This section is an overview of the operation of the CPU bus to establish interface requirements.

Overview

The NEC VR4181A is designed around the RISC architecture developed by MIPS. This microprocessor is designed around the 100MHz VR4110 CPU core which supports the MIPS III and MIPS16 instruction sets. The CPU communicates with external devices via an ISA interface.

The NEC VR4181A has direct support for an external LCD controller. A 64 to 512-kilobyte block of memory is assigned to the LCD controller with a dedicated chip select signal. Word or byte accesses are controlled by the system high byte signal, #UBE.

LCD Memory Access Signals

The S1D13705 requires an addressing range of 128Kbytes. When the VR4181A's external LCD controller chip select signal is programmed to a window of that size, the S1D13705 must reside in the VR4181A physical address range of 133E 0000h to 133F FFFFh which is part of the external ISA memory space.

The signals required for external LCD controller access are listed below and obey ISA signalling rules.

- A[16:0]Address bus
- #UBEHigh byte enable (active low)
- #LDCDSLCD controller (S1D13705) chip select (active low)
- D[15:0]Data bus
- #MEMRDRead command (active low)
- #MEMWRWrite command (active low)
- #MEMCS16Sixteen-bit peripheral capability acknowledge (active low)
- IORDYReady signal from S1D13705
- SYSCLKOptional, prescalable bus clock

Once an address in the LCD block of memory is accessed, the LCD chip select #LCDCS is driven low. The read or write enable signals, #MEMRD or #MEMWR, are driven low for the appropriate cycle and IORDY is driven low by the S1D13705 to insert wait states into the cycle. The high byte enable is driven low for 16-bit transfers and high for 8-bit transfers.

8.3 S1D13705 Host Bus Interface

This section is a summary of the host bus interface modes available on the S1D13705 that would be used to interface to the VR4181A.

The S1D13705 implements a 16-bit interface to the host microprocessor which may operate in one of several modes compatible with most of the popular embedded microprocessor families. The interface mode used for the VR4181A is:

- Generic #2 (External Chip Select, shared Read/Write Enable for high byte, individual Read/Write Enable for low byte).

Host Bus Pin Connection

Table 8-1 Host Bus Interface Pin Mapping

S1D13705 Pin Names	Generic #2
AB[16:1]	A[16:1]
AB0	A0
DB[15:0]	D[15:0]
WE1#	BHE#
CS#	External Decode
BCLK	BCLK
BS#	Connect to IO V _{DD}
RD/WR#	Connect to IO V _{DD}
RD#	RD#
WE0#	WE#
WAIT#	WAIT#
RESET#	RESET#

For details on configuration, refer to the “S1D13705 Hardware Functional Specification”, document number X27A-A-001-02.

Generic #2 Interface Mode

Generic #2 interface mode is a general and non-processor-specific interface mode on the S1D13705. The Generic # 2 interface mode was chosen for this interface due to the simplicity of its timing and compatibility with the VR4181A control signals.

The interface requires the following signals:

- BUSCLK is a clock input which synchronizes transfers between the host CPU and the S1D13705. It is separate from the input clock (CLKI) and is typically driven by the host CPU system clock.
- The address inputs AB0 through AB16, and the data bus DB0 through DB15, connect directly to the CPU address and data bus, respectively. On 32-bit big endian architectures such as the Power PC, the data bus would connect to the high-order data lines; on little endian hosts, or 16-bit big endian hosts, they would connect to the low-order data lines. The hardware engineer must ensure that CNF3 selects the proper endian mode upon reset.
- Chip Select (CS#) is driven by decoding the high-order address lines to select the proper register and memory address space.
- WE1# is the high byte enable for both read and write cycles.

- WE0# is the write enable signal for the S1D13705, to be driven low when the host CPU is writing data from the S1D13705.
- RD# is the read enable for the S1D13705, to be driven low when the host CPU is reading data from the S1D13705.
- WAIT# is a signal which is output from the S1D13705 to the host CPU that indicates when data is ready (read cycle) or accepted (write cycle) on the host bus. Since host CPU accesses to the S1D13705 may occur asynchronously to the display update, it is possible that contention may occur in accessing the S1D13705 internal registers or memory. The WAIT# line resolves these contentions by forcing the host to wait until the resource arbitration is complete. This signal is active low and may need to be inverted if the host CPU wait state signal is active high.
- The Bus Status (BS#) and Read/Write (RD/WR#) signals are not used in the bus interface for Generic #2 mode. However, BS# is used to configure the S1D13705 for Generic #2 mode and should be tied high (connected to IOV_{DD}). RD/WR# should also be tied high.

8.4 VR4181A to S1D13705 Interface

Hardware Description

The NEC VR4181A microprocessor is specifically designed to support an external LCD controller by providing the internal address decoding and control signals necessary. By using the Generic # 2 interface, a glueless interface is achieved. The diagram below shows a typical implementation of the VR4181A to S1D13705 interface.

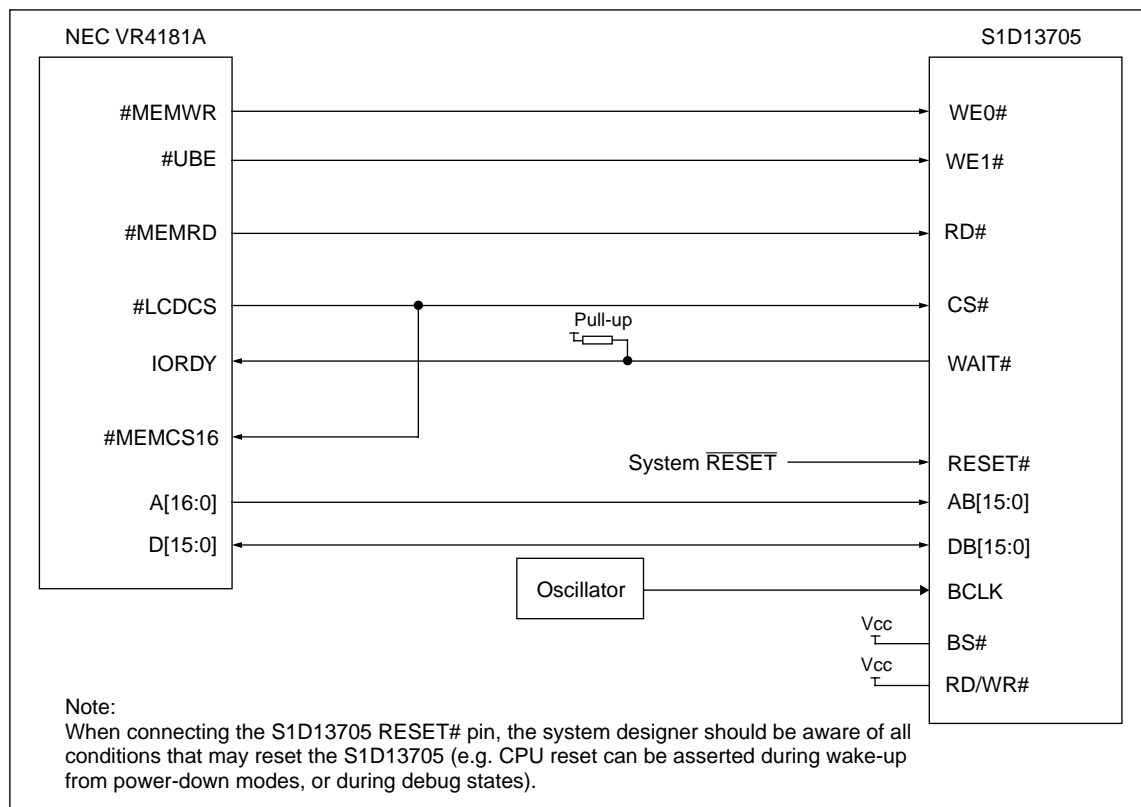

Figure 8-1 Typical Implementation of VR4181A to S1D13705 Interface

The host interface control signals of the S1D13705 are asynchronous with respect to the S1D13705 bus clock. This gives the system designer full flexibility to choose the appropriate source (or sources) for CLKI and BCLK. The choice of whether both clocks should be the same, and whether an external or internal clock divider is needed, should be based on the desired:

- pixel and frame rates.
- power budget.
- part count.
- maximum S1D13705 clock frequencies.

The S1D13705 also has internal clock dividers providing additional flexibility.

S1D13705 Hardware Configuration

The S1D13705 uses CNF3 through CNF0 and BS# to allow selection of the bus mode and other configuration data on the rising edge of RESET#. Refer to the “S1D13705 Hardware Functional Specification”, document number X27A-A-001-02 for details.

The tables below show those configuration settings important to the Generic #2 host bus interface.

Table 8-2 Summary of Power-On/Reset Options

Signal	value on this pin at the rising edge of RESET# is used to configure: (0/1)	
	0	1
CNF0	See “Host Bus Interface Selection” table8-3 below.	See “Host Bus Interface Selection” table8-3 below.
CNF1		
CNF2		
CNF3	Little Endian	Big Endian



 = configuration for NEC VR4181A support

Table 8-3 Host Bus Interface Selection

CNF2	CNF1	CNF0	BS#	Host Bus Interface
1	1	1	1	Generic #2, 16-bit

 = configuration for NEC VR4181A support

NEC VR4181A Configuration

The NEC VR4181A must be configured through its internal registers in order to map the S1D13705 to the external LCD controller space. The following register values must be set.

Register LCDGPMD at address 0B00 032Eh must be set as follows.

- Bit 7 must be set to 1 to disable the internal LCD controller and enable the external LCD controller interface. This also maps pin SHCLK to #LCDCS and pin LOCLK to #MEMCS16.
- Bits [1:0] must be set to 01b to reserve 128Kbytes of memory address range 133E 0000h to 133F FFFFh for the external LCD controller.

Register GPMD2REG at address 0B00 0304h must be set as follows.

- Bits [9:8] (GP20MD[1:0]) must be set to 11b to map pin GPIO20 to #UBE.
- Bits [5:4] (GP18MD[1:0]) must be set to 01b to map pin GPIO18 to IORDY.

8.5 *Software*

Test utilities and Windows® CE v2.0 display drivers are available for the S1D13705. Full source code is available for both the test utilities and the drivers.

The test utilities are configurable for different panel types using a program called 1375CFG, or by directly modifying the source. The Windows® CE v2.0 display drivers can be customized by the OEM for different panel types, resolutions and color depths only by modifying the source.

9 S1D13705 POWER CONSUMPTION

9.1 S1D13705 Power Consumption

S1D13705 power consumption is affected by many system design variables.

- Input clock frequency (CLKI): the CLKI frequency and the internal clock divide register determine the operating clock (CLK) frequency of the S1D13705. The higher CLK is, the higher the frame rate, performance, and power consumption.
- CPU interface: the S1D13705 current consumption depends on the BUSCLK frequency, data width, number of toggling pins, and other factors – the higher the BUSCLK, the higher the CPU performance and power consumption.
- V_{DD} voltage levels (Core and IO): the voltage level of the Core and IO sections in the S1D13705 affects power consumption – the higher the voltage, the higher the consumption.
- Display mode: the resolution, panel type, and color depth affect power consumption. The higher the resolution/color depth and number of LCD panel signals, the higher the power consumption.

Note: If the High Performance option is turned on, the power consumption increases to that of 8 bit-per-pixel mode for all color depths.

There are two power save modes in the S1D13705: Software and Hardware Power Save. The power consumption of these modes is affected by various system design variables.

- CPU bus state during Power Save: the state of the CPU bus signals during Power Save has a substantial effect on power consumption. An inactive bus (e.g. BUSCLK = low, Addr = low etc.) reduces overall system power consumption.
- CLKI state during Power Save: disabling the CLKI during Power Save has substantial power savings.

Conditions

Table 9-1 below gives an example of a specific environment and its effects on power consumption.

Table 9-1 S1D13705 Total Power Consumption

Test Condition Core V _{DD} = 3.3V, IO V _{DD} = 3.3V BUSCLK = 8.33MHz		Gray Shades / Colors	Power Consumption				
			Active			Power Save Mode	
			Core	IO	Total	Software	Hardware
1	Input Clock = 6MHz LCD Panel = 320x240 4-bit Single Mono- chrome	Black-and-White	4.29mW	0.52mW	4.81mW	1.44mW ¹	1.21mW ²
		4 Gray Shades	4.99mW	0.76mW	5.75mW		
		16 Gray Shades	6.13mW	0.75mW	6.88mW		
2	Input Clock = 6MHz LCD Panel = 320x240 4-bit Single Color	2 Colors	4.64mW	0.73mW	5.37mW	1.44mW ¹	1.22mW ²
		4 Colors	5.30mW	1.51mW	6.81mW		
		16 Colors	6.58mW	1.57mW	8.15mW		
		256 Colors	8.65mW	1.52mW	10.16mW		
3	Input Clock = 25MHz LCD Panel = 640x480 8-bit Single Mono- chrome	Black-and-White	13.97mW	1.10mW	15.07mW	2.53mW ¹	2.32mW ²
		4 Gray Shades	16.75mW	2.08mW	18.83mW		
4	Input Clock = 25MHz LCD Panel = 640x480 8-bit Single Color	2 Colors	15.53mW	2.64mW	18.17mW	2.53mW ¹	2.32mW ²
		4 Colors	18.30mW	7.16mW	25.47mW		
5	Input Clock = 25MHz LCD Panel = 640x480 8-bit Dual Mono- chrome	Black-and-White	13.84mW	1.08mW	14.93mW	2.53mW ¹	2.32mW ²
		4 Grey Shades	20.38mW	2.07mW	22.45mW		
6	Input Clock = 25MHz LCD Panel = 640x480 8-bit Dual Color	2 Colors	15.82mW	2.62mW	18.44mW	2.53mW ¹	2.32mW ²
		4 Colors	23.31mW	7.01mW	30.32mW		
7	Input Clock = 25MHz LCD Panel = 640x480 9-bit TFT	2 Colors	11.42mW	7.40mW	18.82mW	2.53mW ¹	2.32mW ²
		4 Colors	19.74mW	20.96mW	40.70mW		

Note: 1. Conditions for Software Power Save:

- CPU interface active (signals toggling)
- CLKI active

2. Conditions for Hardware Power Save:

- CPU interface inactive (high impedance)
- CLKI active

9.2 Summary

The system design variables in Section 9.1, “S1D13705 Power Consumption” and in Table 9-1 show that S1D13705 power consumption depends on the specific implementation. Active Mode power consumption depends on the desired CPU performance and LCD frame-rate, whereas Power Save Mode consumption depends on the CPU Interface and Input Clock state.

In a typical design environment, the S1D13705 can be configured to be an extremely power-efficient LCD Controller with high performance and flexibility.

THIS PAGE IS BLANK.

S1D13705F00A
Embedded Memory LCD Controller

Windows® CE
Display Drivers

1 WINDOWS® CE DISPLAY DRIVERS	6-1
1.1 Program Requirements	6-1
1.2 Example Driver Builds	6-1
Build For CEPC (X86) for Windows® CE Versions 2.0 thru 2.1	6-1
Build For CEPC (X86) for Windows® CE Version 2.11 (Platform Builder)	6-2
1.3 Example Installation	6-4
Installation for CEPC Environment	6-4
1.4 Comments	6-4

1 Windows® CE DISPLAY DRIVERS

The Windows® CE display drivers are designed to support the S1D13705 Embedded Memory LCD Controller running under the Microsoft Windows® CE operating system. Available drivers include: 4 and 8 bit-per-pixel landscape modes, and 4 and 8 bit-per-pixel portrait modes.

1.1 Program Requirements

Video Controller	:	S1D13705
Display Type	:	LCD or CRT
Windows® Version	:	CE Versions 2.0 thru 2.11

1.2 Example Driver Builds

Build For CEPC (X86) for Windows® CE Versions 2.0 thru 2.1

To build a Windows® CE v2.0 or v2.1 display driver for the CEPC (X86) platform using an S5U13705B00C evaluation board, follow the instructions below:

1. Install Microsoft Windows® NT v4.0.
2. Install Microsoft Visual C/C++ v5.0.
3. Install the Microsoft Windows® CE Embedded Toolkit (ETK) by running SETUP.EXE from the ETK compact disc #1.
4. Create a new project by following the procedure documented in “Creating a New Project Directory” from the Windows® CE ETK v2.0. Alternately, use the current “DEMO7” project included with the ETK v2.0. Follow the steps below to create a “X86 DEMO7” shortcut on the Windows® NT v4.0 desktop which uses the current “DEMO7” project:
 - a. Right click on the “Start” menu on the taskbar.
 - b. Click on the item “Open All Users” and the “Start Menu” window will come up.
 - c. Click on the icon “Programs”.
 - d. Click on the icon “Windows® CE Embedded Development Kit”.
 - e. Drag the icon “X86 DEMO1” onto the desktop using the right mouse button.
 - f. Click on “Copy Here”.
 - g. Rename the icon “X86 DEMO1” on the desktop to “X86 DEMO7” by right clicking on the icon and choosing “rename”.
 - h. Right click on the icon “X86 DEMO7” and click on “Properties” to bring up the “X86 DEMO7 Properties” window.
 - i. Replace the string “DEMO1” under the entry “Target” with “DEMO7”.
 - j. Click on “OK” to finish.
5. Create a sub-directory named 8BPP1375 under \wince\platform\cepc\drivers\display.
6. Copy the source code to the 8BPP1375 subdirectory.
7. Add an entry for the 8BPP1375 in the file \wince\platform\cepc\drivers\display\dirs.
8. Since the S5U13705B00C maps memory to 0xF00000, the CEPC machine should use the CMOS setup to create a 1M byte hole from address 0xF00000 to 0xFFFFF.

9. Edit the file PLATFORM.BIB (located in X:\wince\platform\cepc\files) to set add the display driver 8BPP1375.DLL. 8BPP1375.DLL will be created during the build in step 11.

Add the following lines in PLATFORM.BIB:

```
IF CEPC_DDI_8BPP1375
ddi.dll      $_FLATRELEASEDIR\8BPP13705.dllNK SH
ENDIF
```

before these lines:

```
IF CEPC_DDI_VGA2BPP
ddi.dll      $_FLATRELEASEDIR\ddi_vga2.dllNK SH
ENDIF
IF CEPC_DDI_VGA8BPP
ddi.dll      $_FLATRELEASEDIR\ddi_vga8.dllNK SH
ENDIF
```

and this line:

```
IF CEPC_DDI_8BPP1375 !
```

before these lines that test before dropping into the default display driver:

```
IF CEPC_DDI_VGA2BPP !
IF CEPC_DDI_VGA8BPP !
ddi.dll      $_FLATRELEASEDIR\ddi_s364.dllNK SH
ENDIF
ENDIF
```

and finally to match the added IF:

```
ENDIF
```

10. Generate the proper building environment by double-clicking on the sample project icon (i.e. X86 DEMO7).
11. Type BLDDemo <ENTER> at the DOS prompt of the X86 DEMO7 window to generate a Windows® CE image file (NK.BIN).

Build For CEPC (X86) for Windows® CE Version 2.11 (Platform Builder)

To build a Windows® CE v2.11 display driver for the CEPC (X86) platform using an S5U13705B00C evaluation board, follow the instructions below:

1. Install Microsoft Windows® NT v4.0.
2. Install Microsoft Visual C/C++ v5.0.
3. Install Platform Builder 2.11.
4. Create a backup copy of the MAXALL.BAT by duplicating the MAXALL.BAT file in Windows® NT Explorer, then add an environment variable to select the 8BPP1375 driver.
 - a. Change to the \WINCE211\PUBLIC\MAXALL directory.
 - b. Click on the file MAXALL.BAT, then right click and Copy the MAXALL.BAT file (\WINCE211\PUBLIC\MAXALL\MAXALL.BAT).
 - c. Right click again and select Paste in this same directory. A new file called "Copy of MAXALL" will appear, this is a backup of the original file.
 - d. Edit the file MAXALL.BAT by right clicking and selecting Edit, and add the following lines to the end of the file (Note that the line "set WINCEREL=1" fixes a problem with some versions of Platform Builder):

```
@echo on
set WINCEREL=1
```

```
set CEPC_DDI_8BPP1375=1
@echo off.
```

5. Install 1375 CEPC driver
 - a. copy 1375 driver into

```
\WINCE211\PLATFORM\CEPC\DRIVERS\DISPLAY\8BPP1375
```
 - a. add 8BPP1375 into the directory list in file

```
\WINCE211\PLATFORM\CEPC\DRIVERS\DISPLAY\dirs
```
6. Edit the file PLATFORM.BIB (located in X:\wince211\platform\cepc\files) to add a display driver for 8BPP1375.DLL. 8BPP1375.DLL will be created during the build in step 9.

Add the following lines in PLATFORM.BIB:

```
IF CEPC_DDI_8BPP1375
ddi.dll      $_FLATRELEASEDIR)\8BPP1375.dllNK SH
ENDIF
```

before these lines:

```
IF CEPC_DDI_VGA8BPP
ddi.dll      $_FLATRELEASEDIR)\ddi_vga8.dllNK SH
ENDIF
```

and this line:

```
IF CEPC_DDI_8BPP1375 !
```

before these lines that test before dropping into the default display driver:

```
IF CEPC_DDI_VGA8BPP !
ddi.dll      $_FLATRELEASEDIR)\ddi_s364.dllNK SH
ENDIF
```

and finally add an ENDIF after the first ENDIF to match the added IF:

```
ENDIF
```

7. Cleanup platform builder as normal (remove the \wince211\release directory and delete \wince211\platform\cepc*.bif).
8. Generate the proper building environment by selecting “Build Maxall for x86” from the Start Menu. You should see an echo of the lines added earlier to MAXALL.BAT:

```
set WINCEREL=1
set CEPC_DDI_8BPP1375=1
```

9. Type BLDDEMO <ENTER> at the DOS prompt of the “Build Maxall for x86” window to generate a Windows® CE image file (NK.BIN).

1.3 Example Installation

Installation for CEPC Environment

Windows® CE v2.0 can be loaded on a PC using a floppy drive or a hard drive. The two methods are described below:

1. To load CEPC from a floppy drive:
 - a. Create a DOS bootable floppy disk.
 - b. Edit CONFIG.SYS on the floppy disk to contain the following line only.
device=a:\himem.sys
 - c. Edit AUTOEXEC.BAT on the floppy disk to contain the following lines.
mode com1:9600,n,8,1
loadcepc /B:9600 /C:1 /D:2 c:\wince\release\nk.bin
 - d. Copy LOADCEPC.EXE from c:\wince\public\common\oak\bin to the bootable floppy disk.
 - e. Confirm that NK.BIN is located in c:\wince\release.
 - f. Reboot the system from the bootable floppy disk.
2. To load CEPC from a hard drive:
 - a. Copy LOADCEPC.EXE to the root directory of the hard drive.
 - b. Edit CONFIG.SYS on the hard drive to contain the following line only.
device=c:\himem.sys
 - c. Edit AUTOEXEC.BAT on the hard drive to contain the following lines.
mode com1:9600,n,8,1
loadcepc /B:9600 /C:1 /D:2 c:\wince\release\nk.bin
 - d. Confirm that NK.BIN is located in c:\wince\release.
 - e. Reboot the system from the hard drive.

1.4 Comments

- Alternatively, in the examples above, you could substitute 4BPP instead of 8BPP.
- On some CEPC systems creating the 1M byte address hole will cause LOADCEPC.EXE to fail. In this case contact your Sales Representative for a newer version of LOADCEPC.EXE called LOAD211X.EXE.

AMERICA

EPSON ELECTRONICS AMERICA, INC.

- HEADQUARTERS -

150 River Oaks Parkway
San Jose, CA 95134, U.S.A.
Phone: +1-408-922-0200 Fax: +1-408-922-0238

- SALES OFFICES -

West

1960 E. Grand Avenue
El Segundo, CA 90245, U.S.A.
Phone: +1-310-955-5300 Fax: +1-310-955-5400

Central

101 Virginia Street, Suite 290
Crystal Lake, IL 60014, U.S.A.
Phone: +1-815-455-7630 Fax: +1-815-455-7633

Northeast

301 Edgewater Place, Suite 120
Wakefield, MA 01880, U.S.A.
Phone: +1-781-246-3600 Fax: +1-781-246-5443

Southeast

3010 Royal Blvd. South, Suite 170
Alpharetta, GA 30005, U.S.A.
Phone: +1-877-EEA-0020 Fax: +1-770-777-2637

EUROPE

EPSON EUROPE ELECTRONICS GmbH

- HEADQUARTERS -

Riesstrasse 15
80992 Munich, GERMANY
Phone: +49-(0)89-14005-0 Fax: +49-(0)89-14005-110

SALES OFFICE

Altstadtstrasse 176
51379 Leverkusen, GERMANY
Phone: +49-(0)2171-5045-0 Fax: +49-(0)2171-5045-10

UK BRANCH OFFICE

Unit 2.4, Doncastle House, Doncastle Road
Bracknell, Berkshire RG12 8PE, ENGLAND
Phone: +44-(0)1344-381700 Fax: +44-(0)1344-381701

FRENCH BRANCH OFFICE

1 Avenue de l'Atlantique, LP 915 Les Conquerants
Z.A. de Courtaboeuf 2, F-91976 Les Ulis Cedex, FRANCE
Phone: +33-(0)1-64862350 Fax: +33-(0)1-64862355

BARCELONA BRANCH OFFICE

Barcelona Design Center
Edificio Testa
Avda. Alcalde Barrils num. 64-68
E-08190 Sant Cugat del Vallès, SPAIN
Phone: +34-93-544-2490 Fax: +34-93-544-2491

ASIA

EPSON (CHINA) CO., LTD.

23F, Beijing Silver Tower 2# North RD DongSanHuan ChaoYang
District, Beijing, CHINA
Phone: 64106655 Fax: 64107319

SHANGHAI BRANCH

4F, Bldg., 27, No. 69, Gui Jing Road
Caohejing, Shanghai, CHINA
Phone: 21-6485-5552 Fax: 21-6485-0775

EPSON HONG KONG LTD.

20/F., Harbour Centre, 25 Harbour Road
Wanchai, Hong Kong
Phone: +852-2585-4600 Fax: +852-2827-4346
Telex: 65542 EPSCO HX

EPSON TAIWAN TECHNOLOGY & TRADING LTD.

10F, No. 287, Nanking East Road, Sec. 3
Taipei
Phone: 02-2717-7360 Fax: 02-2712-9164
Telex: 24444 EPSONTB

HSINCHU OFFICE

13F-3, No. 295, Kuang-Fu Road, Sec. 2
HsinChu 300
Phone: 03-573-9900 Fax: 03-573-9169

EPSON SINGAPORE PTE., LTD.

No. 1 Temasek Avenue, #36-00
Millenia Tower, SINGAPORE 039192
Phone: +65-337-7911 Fax: +65-334-2716

SEIKO EPSON CORPORATION

KOREA OFFICE

50F, KLI 63 Bldg., 60 Yoido-dong
Youngdeungpo-Ku, Seoul, 150-763, KOREA
Phone: 02-784-6027 Fax: 02-767-3677

SEIKO EPSON CORPORATION

ELECTRONIC DEVICES MARKETING DIVISION

Electronic Device Marketing Department

IC Marketing & Engineering Group

421-8, Hino, Hino-shi, Tokyo 191-8501, JAPAN
Phone: +81-(0)42-587-5816 Fax: +81-(0)42-587-5624

ED International Marketing Department

Europe & U.S.A.

421-8, Hino, Hino-shi, Tokyo 191-8501, JAPAN
Phone: +81-(0)42-587-5812 Fax: +81-(0)42-587-5564

ED International Marketing Department

Asia

421-8, Hino, Hino-shi, Tokyo 191-8501, JAPAN
Phone: +81-(0)42-587-5814 Fax: +81-(0)42-587-5110



In pursuit of “**Saving**” **Technology**, Epson electronic devices.
Our lineup of semiconductors, liquid crystal displays and quartz devices
assists in creating the products of our customers’ dreams.
Epson IS energy savings.

SEIKO EPSON CORPORATION
ELECTRONIC DEVICES MARKETING DIVISION

■ EPSON Electronic Devices Website

<http://www.epson.co.jp/device/>