



**Description**

The Redington Model 34 LCD Hour Meter provides a large display, with 0.28" [7mm] high characters, in the industry size housings. The Hour Meters are available in 8 different housings, including a surface mount inductive input model. All models are totally sealed and are capable of submersion in 6' [2 meters] of water. A wide operating voltage, 10-300VDC and 20-300VAC, and inductive input make the Model 34 versatile for all indoor and outdoor applications. All models are NEMA 4/4X, 12, & IP66 rated when used with the optional gasket and have a polarized lens which assures high visibility in an outdoor environment.

Maintenance Meters are offered with a maximum of 3 "Redi-Alerts" to alert users when service is due. Models are available with front panel field or factory programmable alerts. Not only does the display flash to get attention, but it displays a choice of 7 different .08"[2mm] maintenance icons. Models are available as a Preset Timer with a MOSFET output for the actuation of external alarms or indicator lamps. Users can program or specify the service interval and flash duration for each Redi-Alert. Flash duration is the amount of time in hours that the specific icon flashes before and after the service interval. If a front panel manual reset of the Redi-Alert is required the front panel models with switches must be specified.

**Features**

- Totally sealed from moisture and dirt
- AC or DC voltage input in the same unit
- Tachometer/Hour Meter versions
- Compact depth
- Programmable output thresholds
- Preset Hour Meter/time up or down
- Up to 3 Redi-Alerts/7 icons
- Fits in existing panel openings
- Always on display
- A choice of 8 housings
- A choice of reset modes
- Front panel programmable
- Preset Timer with output
- Can be programmed with starting time
- 15+ Year Battery Life

**Specifications**

<b>Display:</b>	LCD with large 0.28" [7mm] high figures black on light background	<b>Maximum Withstanding voltage:</b> 30VDC, reference to Common
		<b>Maximum Load current:</b> 0.1Amp
<b>Run indicator:</b>	Blinking decimal point	<b>Environmental:</b>
<b>Reset:</b>	Remote, manual and non-reset (remote reset not available on surface mount housing)	Temperature: (Storage and Operating) -40 to +185°F [-40 to +85°C]
<b>Hour Meter Resolution:</b>	0.01 or 0.1 Hour, displayed; 1 second, internal	Humidity: 95% RH per SAE J1378
<b>Accuracy:</b>	± 0.1% @ room temperature ± 0.2% over the specified temperature range	Vibration: 20g @ 10 to 80 Hz per SAE J1378
<b>Records &amp; Displays:</b>	9999999.9 - hours & 1/10's or 999999.99 - hours & 1/100's	Shock: 44 to 55g's per SAE J1378
<b>Inputs:</b>	10-300VDC and 20-300VAC-50/60Hz VIH 20VAC or 10VDC minimum VIL 3VAC or 3VDC maximum	Dielectric: 1000VAC 50/60 Hz for 1 minute
<b>Power:</b>	Self powered - battery life 15+ years	Compliance: Compliant to the European WEEE and RoHS Directives
<b>Terminations:</b>	Standard 0.250" [6.4mm] spades 1 meter wire (inductive)	<b>Sealing:</b> Totally sealed
<b>Output:</b>	Format: Open-Drain MOSFET with Source connected to Common (see note 3)	<b>EMC Compliance:</b> EN61326:1997 with A1:1998 and A2:2001 for industrial environments
		<b>Protection Against:</b> Alternator load dump: 150V EMI (Electromagnetic Interface): +400V @ 500Hz inductive switching and reverse polarity
		<b>Enclosure:</b> Totally sealed from moisture and dirt, NEMA 4/4X, 12, & IP66 compliant from the front when properly mounted using the optional gasket. (Not applicable to Snap-In Model)
		<b>Approvals:</b> UL and cUL Recognized (file # ELIY2.E36690), CE, SAE, NEMA 4/4X compliant
		<b>Weight:</b> 1oz [28g]



Functions

Preset Hour Meter: The preset function is centered on the output signal. When the time reaches the preset value, the output signal is turned "on". The Preset function is time "up". Upon reaching the preset value the preset can be automatically reset, or it can await an external reset.

Inductive Models: The surface mount Inductive unit is designed with an inductive interface. The unit will sense the firing of a spark plug on most small gasoline powered internal combustion engines. The wire lead from the unit is wrapped around the spark plug wire. Inductive models are available with and without tachometers. Most small engines provide 1 spark per RPM, in which case the maximum RPM is 30,000. Some small engines provide 2 sparks per RPM, the maximum RPM is then 15,000. Models are available that can be field (front panel switches) or factory programmed for 1.0, 2.0, or 0.5 sparks/pulses per RPM.

Front Panel Switch Functions: Front panel switches can be used for reset, display selection and programming. The two front Panel switches are used as follows:

SEL: During programming this switch is used to select options. The SEL switch is used during programming to move horizontally in the programming flow chart.

RST: This is the reset switch during normal operation. During programming the RST switch is used to enter an option. The RST switch is used during programming to move vertically in the programming flow chart.

Available Icons

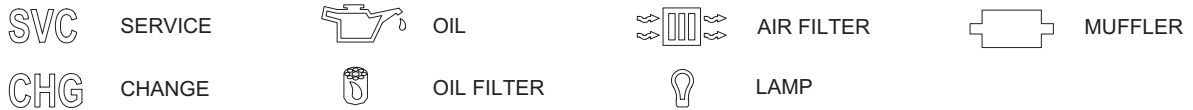

Dimensions

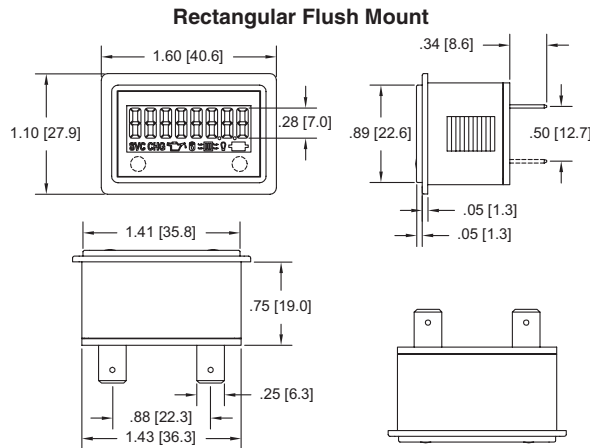

Panel Cutout: 1.45" [36.8mm] x 0.95" [24.1mm]
Maximum Panel Thickness: 0.375" [9.5mm]

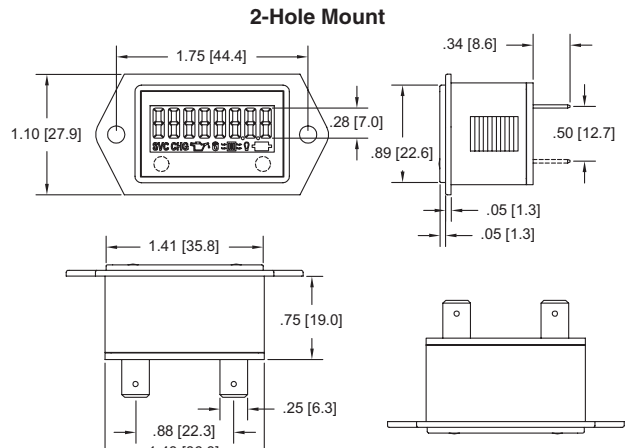

Panel Cutout: 1.45" [36.8mm] x 0.95" [24.1mm]

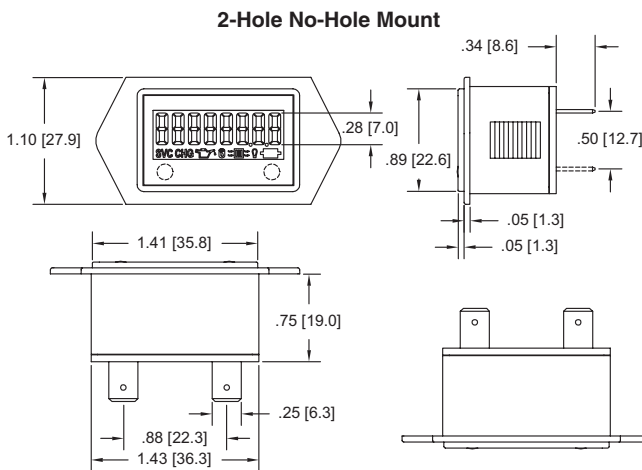

Panel Cutout: 1.45" [36.8mm] x 0.95" [24.1mm]
Maximum Panel Thickness: 0.375" [9.5mm]

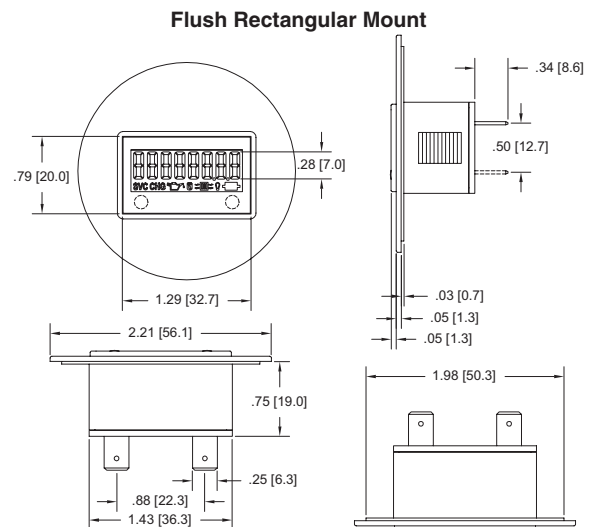

Panel Cutout: 1.45" [36.8mm] x 0.95" [24.1mm]
Maximum Panel Thickness: 0.375" [9.5mm]



3-Hole Mount

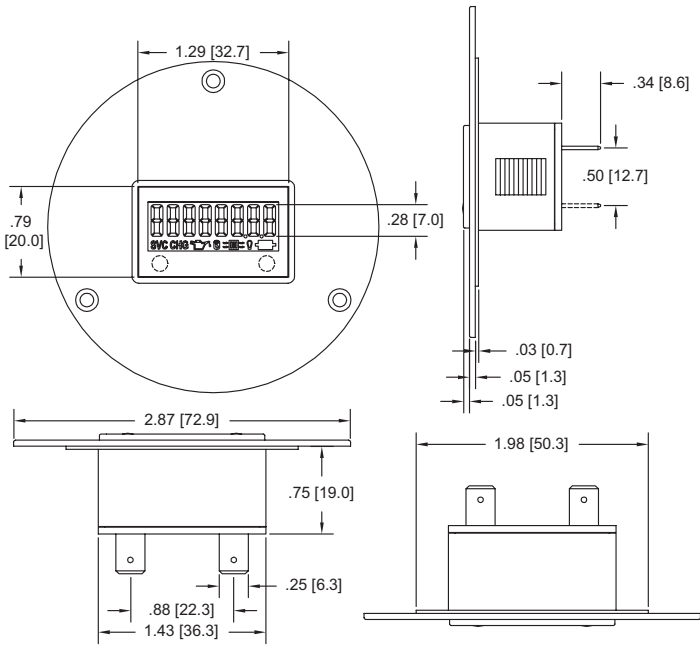

Panel Cutout: 1.45" [36.8mm] x 0.95" [24.1mm]

Snap-In Mount

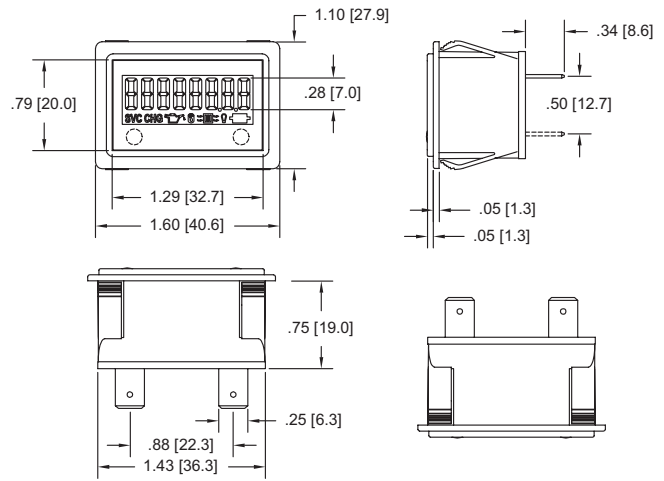

Panel Cutout: 1.46" [37mm] x 0.95" [24.1mm]  
 Minimum Panel Thickness: 0.04" [1.0mm]  
 Maximum Panel Thickness: 0.125" [3.18mm]

Square Flush Mount

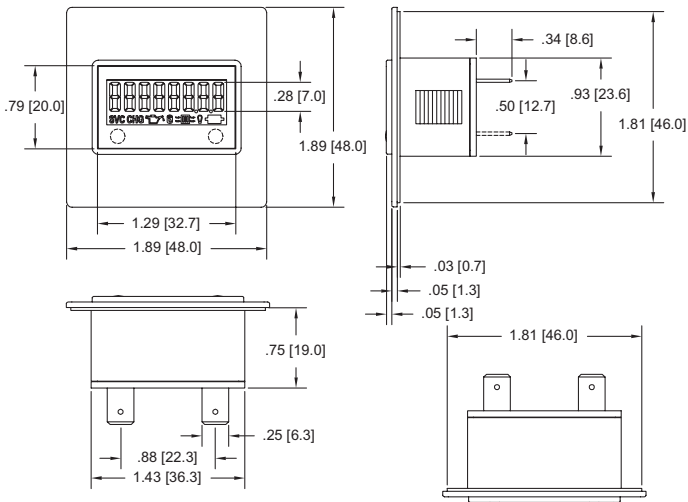

Panel Cutout: 1.45" [36.8mm] x 0.95" [24.1mm]  
 Maximum Panel Thickness: 0.375" [9.5mm]

Surface Mount

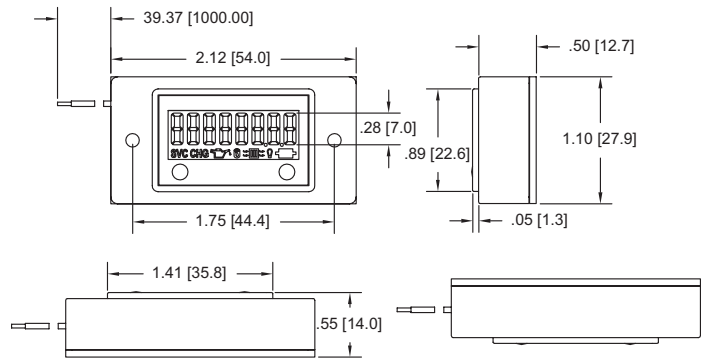

Notes

1. When interfacing the Model 34 with a Solid State Relay or AC Sensor, the leakage current needs to be considered. Contact the factory or see the application note at [www.redingtoncounters.com](http://www.redingtoncounters.com)
2. Exceeding the Absolute Voltage Range and the Absolute Maximum Limits may result in damage to the unit.
3. The open-drain MOSFET acts like an open-collector NPN transistor. Care should be taken since there is no current limiting protection in the unit.

Applications

Medical Devices

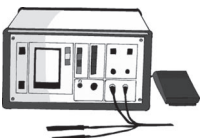

Generators

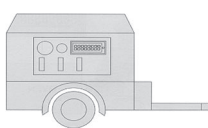

Control Panels

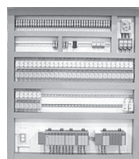

Production Equipment

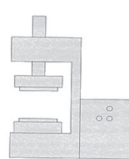

Garden Tractor



Marine Equipment

