



LSM303DLHC

Ultra compact high performance e-compass 3D accelerometer and 3D magnetometer module

Preliminary data

Features

- 3 magnetic field channels and 3 acceleration channels
- From ± 1.3 to ± 8.1 gauss magnetic field full-scale
- $\pm 2g/\pm 4g/\pm 8g/\pm 16g$ selectable full-scale
- 16 bit data output
- I²C serial interface
- Analog supply voltage 2.16 V to 3.6 V
- Power-down mode/ low-power mode
- 2 independent programmable interrupt generators for free-fall and motion detection
- Embedded temperature sensor
- Embedded FIFO
- 6D/4D orientation detection
- ECOPACK[®] RoHS and “Green” compliant

Applications

- Compensated compass
- Map rotation
- Position detection
- Motion-activated functions
- Free-fall detection
- Click/double click recognition
- Pedometer
- Intelligent power-saving for handheld devices
- Display orientation
- Gaming and virtual reality input devices
- Impact recognition and logging
- Vibration monitoring and compensation

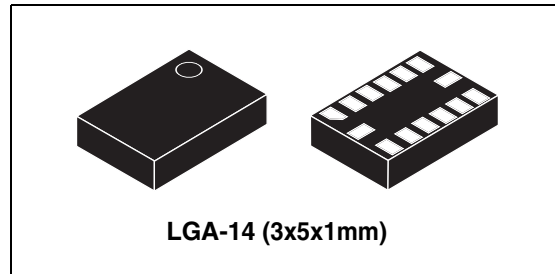

Description

The LSM303DLHC is a system-in-package featuring a 3D digital linear acceleration sensor and a 3D digital magnetic sensor.

LSM303DLHC has linear acceleration full-scales of $\pm 2g / \pm 4g / \pm 8g / \pm 16g$ and a magnetic field full-scale of $\pm 1.3 / \pm 1.9 / \pm 2.5 / \pm 4.0 / \pm 4.7 / \pm 5.6 / \pm 8.1$ gauss. All full-scales available are fully selectable by the user.

LSM303DLHC includes an I²C serial bus interface that supports standard and fast mode 100 kHz and 400kHz. The system can be configured to generate interrupt signals by inertial wake-up/free-fall events as well as by the position of the device itself. Thresholds and timing of interrupt generators are programmable by the end user on the fly. Magnetic and accelerometer parts can be enabled or put into power-down mode separately.

The LSM303DLHC is available in a plastic land grid array package (LGA) and is guaranteed to operate over an extended temperature range from $-40\text{ }^{\circ}\text{C}$ to $+85\text{ }^{\circ}\text{C}$.

Table 1. Device summary

Part number	Temperature range [°C]	Package	Packing
LSM303DLHC	-40 to +85	LGA-14	Tray
LSM303DLHCTR	-40 to +85	LGA-14	Tape and reel

Contents

1	Block diagram and pin description	7
1.1	Block diagram	7
1.2	Pin description	8
2	Module specifications	9
2.1	Sensor characteristics	9
2.2	Temperature sensor characteristics	10
2.3	Electrical characteristics	11
2.4	Communication interface characteristics	12
2.4.1	Sensor I ² C - inter IC control interface	12
2.5	Absolute maximum ratings	13
2.6	Terminology	14
2.6.1	Linear acceleration sensitivity	14
2.6.2	Zero-g level	14
3	Functionality	15
3.1	Factory calibration	15
4	Application hints	16
4.1	External capacitors	16
4.2	Pull-up resistors	16
4.3	Digital interface power supply	17
4.4	Soldering information	17
4.5	High current wiring effects	17
5	Digital interfaces	18
5.1	I ² C serial interface	18
5.1.1	I ² C operation	19
5.1.2	Linear acceleration digital interface	20
5.1.3	Magnetic field digital interface	21
6	Register mapping	22

7	Register description	24
7.1	Linear acceleration register description	24
7.1.1	CTRL_REG1_A (20h)	24
7.1.2	CTRL_REG2_A (21h)	25
7.1.3	CTRL_REG3_A (22h)	25
7.1.4	CTRL_REG4_A (23h)	26
7.1.5	CTRL_REG5_A (24h)	26
7.1.6	CTRL_REG6_A (25h)	27
7.1.7	REFERENCE/DATACAPTURE_A (26h)	27
7.1.8	STATUS_REG_A (27h)	28
7.1.9	OUT_X_L_A (28h), OUT_X_H_A (29h)	28
7.1.10	OUT_Y_L_A (2Ah), OUT_Y_H_A (2Bh)	28
7.1.11	OUT_Z_L_A (2Ch), OUT_Z_H_A (2Dh)	28
7.1.12	FIFO_CTRL_REG_A (2Eh)	29
7.1.13	FIFO_SRC_REG_A (2Fh)	29
7.1.14	INT1_CFG_A (30h)	29
7.1.15	INT1_SRC_A (31h)	30
7.1.16	INT1_THS_A (32h)	31
7.1.17	INT1_DURATION_A (33h)	31
7.1.18	INT2_CFG_A (34h)	31
7.1.19	INT2_SRC_A (35h)	32
7.1.20	INT2_THS_A (36h)	33
7.1.21	INT2_DURATION_A (37h)	33
7.1.22	CLICK_CFG_A (38h)	34
7.1.23	CLICK_SRC_A (39h)	34
7.1.24	CLICK_THS_A (3Ah)	35
7.1.25	TIME_LIMIT_A (3Bh)	35
7.1.26	TIME_LATENCY_A (3Ch)	35
7.1.27	TIME WINDOW_A (3Dh)	36
7.2	Magnetic field sensing register description	36
7.2.1	CRA_REG_M (00h)	36
7.2.2	CRB_REG_M (01h)	37
7.2.3	MR_REG_M (02h)	37
7.2.4	OUT_X_H_M (03), OUT_X_LH_M (04h)	38
7.2.5	OUT_Z_H_M (05), OUT_Z_L_M (06h)	38
7.2.6	OUT_Y_H_M (07), OUT_Y_L_M (08h)	38
7.2.7	SR_REG_M (09h)	38

7.2.8	IR_REG_M (0Ah/0Bh/0Ch)	38
7.2.9	TEMP_OUT_H_M (31h), TEMP_OUT_L_M (32h)	39
8	Package information	40
9	Revision history	41

List of tables

Table 1.	Device summary	1
Table 2.	Pin description	8
Table 3.	Sensor characteristics	9
Table 4.	Temperature sensor characteristics	10
Table 5.	Electrical characteristics	11
Table 6.	I ² C slave timing values	12
Table 7.	Absolute maximum ratings	13
Table 8.	Accelerometer operating mode selection	15
Table 9.	Serial interface pin description	18
Table 10.	Serial interface pin description	18
Table 11.	Transfer when master is writing one byte to slave	19
Table 12.	Transfer when master is writing multiple bytes to slave:	19
Table 13.	Transfer when master is receiving (reading) one byte of data from slave:	19
Table 14.	SAD+read/write patterns.	20
Table 15.	Transfer when master is receiving (reading) multiple bytes of data from slave	20
Table 16.	SAD	21
Table 17.	Register address map.	22
Table 18.	CTRL_REG1_A register	24
Table 19.	CTRL_REG1_A description	24
Table 20.	Data rate configuration	24
Table 21.	CTRL_REG2_A register	25
Table 22.	CTRL_REG2_A description	25
Table 23.	High pass filter mode configuration	25
Table 24.	CTRL_REG3_A register	25
Table 25.	CTRL_REG3_A description	26
Table 26.	CTRL_REG4_A register	26
Table 27.	CTRL_REG4_A description	26
Table 28.	CTRL_REG5_A register	26
Table 29.	CTRL_REG5_A description	27
Table 30.	CTRL_REG6_A register	27
Table 31.	CTRL_REG6_A description	27
Table 32.	REFERENCE_A register	27
Table 33.	REFERENCE_A register description	28
Table 34.	STATUS_A register	28
Table 35.	STATUS_A register description	28
Table 36.	REFERENCE_A register	29
Table 37.	REFERENCE_A register description	29
Table 38.	FIFO mode configuration	29
Table 39.	FIFO_SRC_A register.	29
Table 40.	INT1_CFG_A register.	29
Table 41.	INT1_CFG_A description	29
Table 42.	Interrupt mode	30
Table 43.	INT1_SRC_A register.	30
Table 44.	INT1_SRC_A description	30
Table 45.	INT1_THS_A register	31
Table 46.	INT1_THS_A description	31
Table 47.	INT1_DURATION_A register	31
Table 48.	INT1_DURATION_A description	31

Table 49.	INT2_CFG_A register	31
Table 50.	INT2_CFG_A description	32
Table 51.	Interrupt mode	32
Table 52.	INT2_SRC_A register	32
Table 53.	INT2_SRC_A description	33
Table 54.	INT2_THS_A register	33
Table 55.	INT2_THS_A description	33
Table 56.	INT2_DURATION_A register	33
Table 57.	INT2_DURATION_A description	33
Table 58.	CLICK_CFG_A register	34
Table 59.	CLICK_CFG_A description	34
Table 60.	CLICK_SRC_A register	34
Table 61.	CLICK_SRC_A description	34
Table 62.	CLICK_THS_A register	35
Table 63.	CLICK_SRC_A description	35
Table 64.	TIME_LIMIT_A register	35
Table 65.	TIME_LIMIT_A description	35
Table 66.	TIME_LATENCY_A register	35
Table 67.	TIME_LATENCY_A description	36
Table 68.	TIME_WINDOW_A register	36
Table 69.	TIME_WINDOW_A description	36
Table 70.	CRA_REG_M register	36
Table 71.	CRA_REG_M description	36
Table 72.	Data rate configurations	36
Table 73.	CRA_REG register	37
Table 74.	CRA_REG description	37
Table 75.	Gain setting	37
Table 76.	MR_REG	37
Table 77.	MR_REG description	38
Table 79.	SR register	38
Table 80.	SR register description	38
Table 81.	IRA_REG_M	38
Table 82.	IRB_REG_M	38
Table 83.	IRC_REG_M	39
Table 84.	TEMP_OUT_H_M register	39
Table 85.	TEMP_OUT_L_M register	39
Table 86.	TEMP_OUT resolution	39
Table 87.	Revision history	41

1 Block diagram and pin description

1.1 Block diagram

Figure 1. Block diagram

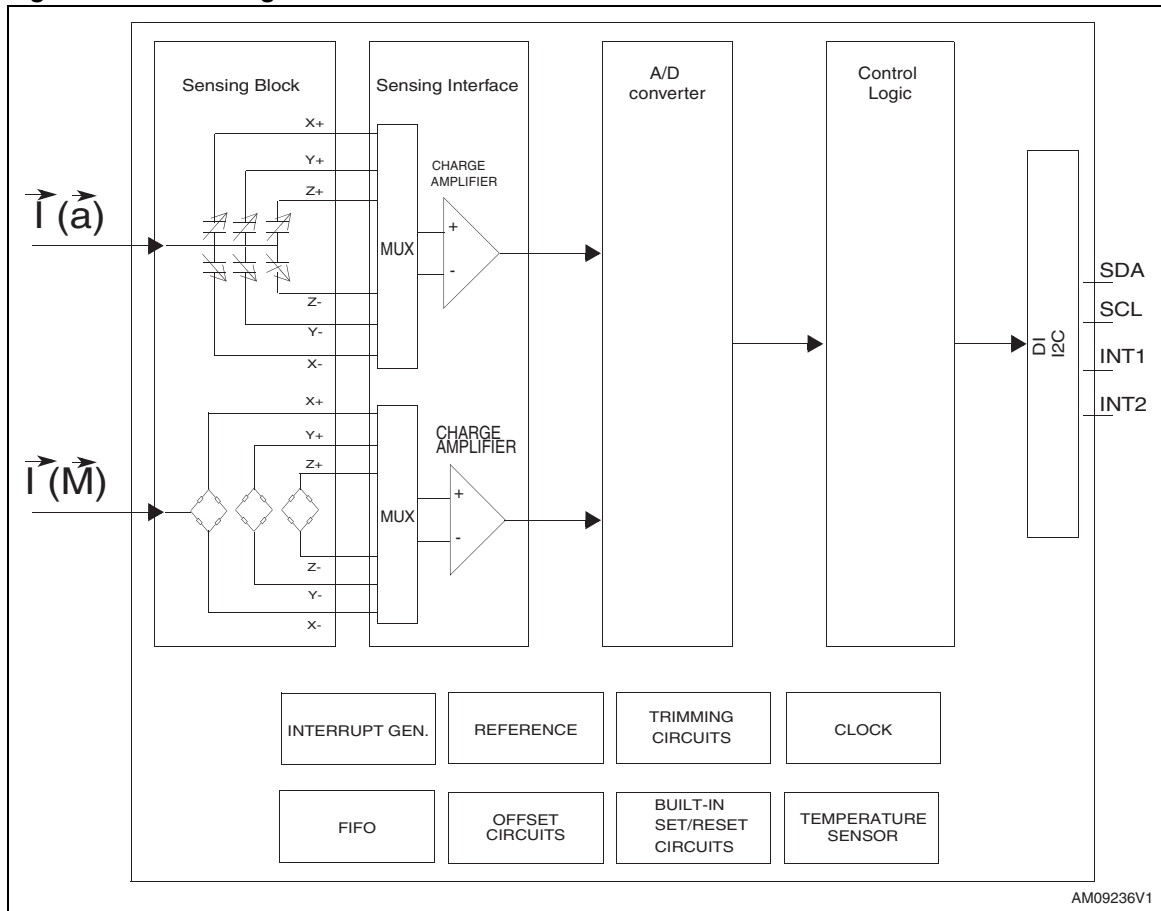

1.2 Pin description

Figure 2. Pin connection

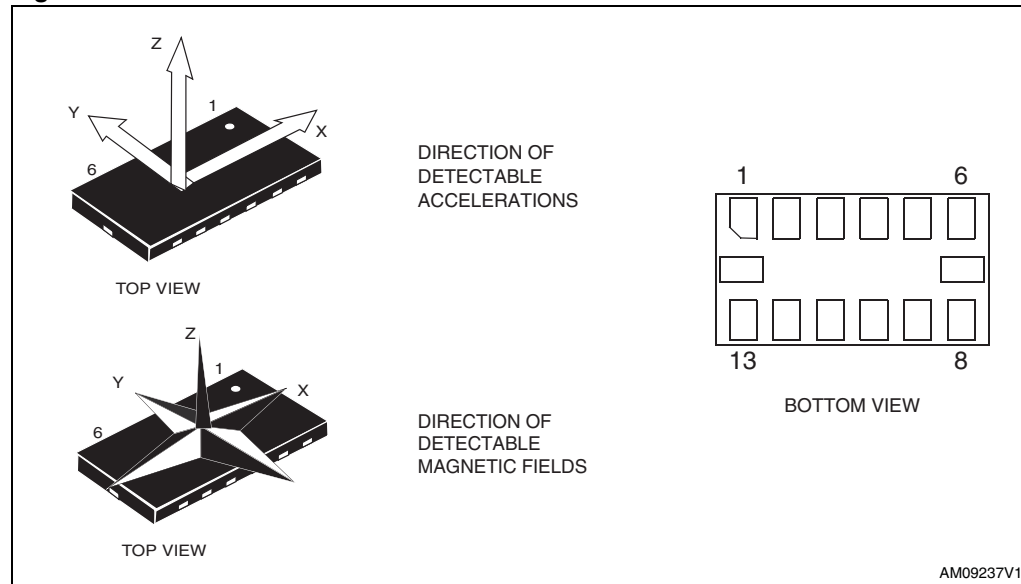

Table 2. Pin description

Pin#	Name	Function
1	Vdd_IO	Power supply for I/O pins
2	SCL	Signal interface I ² C serial clock (SCL)
3	SDA	Signal interface I ² C serial data (SDA)
4	INT2	Inertial Interrupt 2
5	INT1	Inertial Interrupt 1
6	C1	Reserved capacitor connection (C1)
7	GND	0 V supply
8	Reserved	Leave unconnected
9	DRDY	Data ready
10	Reserved	Connect to GND
11	Reserved	Connect to GND
12	SETP	S/R capacitor connection (C2)
13	SETC	S/R capacitor connection (C2)
14	Vdd	Power supply

2 Module specifications

2.1 Sensor characteristics

@ Vdd = 2.5 V, T = 25 °C unless otherwise noted^(a).

Table 3. Sensor characteristics

Symbol	Parameter	Test conditions	Min.	Typ. ⁽¹⁾	Max.	Unit
LA_FS	Linear acceleration measurement range ⁽²⁾	FS bit set to 00		±2		g
		FS bit set to 01		±4		
		FS bit set to 10		±8		
		FS bit set to 11		±16		
M_FS	Magnetic measurement range	GN bits set to 001		±1.3		gauss
		GN bits set to 010		±1.9		
		GN bits set to 011		±2.5		
		GN bits set to 100		±4.0		
		GN bits set to 101		±4.7		
		GN bits set to 110		±5.6		
LA_So	Linear acceleration sensitivity	FS bit set to 00		1		mg/LSB
		FS bit set to 01		2		
		FS bit set to 10		4		
		FS bit set to 11		12		
M_GN	Magnetic gain setting	GN bits set to 001 (X,Y)		1100		LSB/ gauss
		GN bits set to 001 (Z)		980		
		GN bits set to 010 (X,Y)		855		
		GN bits set to 010 (Z)		760		
		GN bits set to 011 (X,Y)		670		
		GN bits set to 011 (Z)		600		
		GN bits set to 100 (X,Y)		450		
		GN bits set to 100 (Z)		400		
		GN bits set to 101 (X,Y)		400		
		GN bits set to 101 (Z)		355		
		GN bits set to 110 (X,Y)		330		
		GN bits set to 110 (Z)		295		
GN bits set to 111 ⁽²⁾ (X,Y)		230				
GN bits set to 111 ⁽²⁾ (Z)		205				

a. The product is factory calibrated at 2.5 V. The operational power supply range is from 2.16 V to 3.6 V.

Table 3. Sensor characteristics (continued)

Symbol	Parameter	Test conditions	Min.	Typ. ⁽¹⁾	Max.	Unit
LA_TCS0	Linear acceleration sensitivity change vs. temperature	FS bit set to 00		±0.01		%/°C
LA_TyOff	Linear acceleration typical Zero- <i>g</i> level offset accuracy ^{(3),(4)}	FS bit set to 00		±60		mg
LA_TCOff	Linear acceleration Zero- <i>g</i> level change vs. temperature	Max. delta from 25 °C		±0.5		mg/°C
LA_An	Acceleration noise density	FS bit set to 00, normal mode(Table 8), ODR bit set to 1001		220		ug/sqrt(Hz)
M_R	Magnetic resolution			2		mgauss
M_CAS	Magnetic cross-axis sensitivity	Cross field = 0.5 gauss H applied = ±3 gauss		±1		%FS/gauss
M_EF	Maximum exposed field	No permitting effect on zero reading			10000	gauss
M_DF	Disturbing field	Sensitivity starts to degrade. Use S/R pulse to restore sensitivity			20	gauss
Top	Operating temperature range		-40		+85	°C

1. Typical specifications are not guaranteed.
2. Verified by wafer level test and measurement of initial offset and sensitivity.
3. Typical Zero-*g* level offset value after MSL3 preconditioning.
4. Offset can be eliminated by enabling the built-in high pass filter.

2.2 Temperature sensor characteristics

@ Vdd = 2.5 V, T = 25 °C unless otherwise noted ^(b).

Table 4. Temperature sensor characteristics

Symbol	Parameter	Test condition	Min.	Typ. ⁽¹⁾	Max.	Unit
TSDr	Temperature sensor output change vs. temperature	-		8		LSB/°C ⁽²⁾
TODR	Temperature refresh rate			ODR ⁽³⁾		Hz
Top	Operating temperature range		-40		+85	°C

1. Typical specifications are not guaranteed.
2. 12-bit resolution.
3. For ODR configuration refer to [Table 72](#).

b. The product is factory calibrated at 2.5 V.

2.3 Electrical characteristics

@ Vdd = 2.5 V, T = 25 °C unless otherwise noted.

Table 5. Electrical characteristics

Symbol	Parameter	Test conditions	Min.	Typ. ⁽¹⁾	Max.	Unit
Vdd	Supply voltage	-	2.16		3.6	V
Vdd_IO	Module power supply for I/O		1.71	1.8	Vdd+0.1	
Idd	Current consumption in normal mode ⁽²⁾			110		μA
IddSL	Current consumption in sleep-mode ⁽³⁾			1		μA
Top	Operating temperature range		-40		+85	°C

1. Typical specifications are not guaranteed.
2. Magnetic sensor setting ODR = 7.5 Hz, Accelerometer sensor ODR = 50 Hz.
3. Linear accelerometer in sleep-mode and magnetic sensor in power-down mode.

2.4 Communication interfaces characteristics

External pull-up resistors are required to support I²C standard and fast speed modes.

2.4.1 Sensor I²C - inter IC control interface

Subject to general operating conditions for Vdd and Top.

Table 6. I²C slave timing values

Symbol	Parameter	I ² C standard mode ⁽¹⁾		I ² C fast mode ⁽¹⁾		Unit
		Min.	Max.	Min.	Max.	
$f_{(SCL)}$	SCL clock frequency	0	100	0	400	KHz
$t_{w(SCLL)}$	SCL clock low time	4.7		1.3		μ s
$t_{w(SCLH)}$	SCL clock high time	4.0		0.6		
$t_{su(SDA)}$	SDA setup time	250		100		ns
$t_h(SDA)$	SDA data hold time	0.01	3.45	0.01	0.9	μ s
$t_r(SDA) t_r(SCL)$	SDA and SCL rise time		1000	$20 + 0.1C_b^{(2)}$	300	ns
$t_f(SDA) t_f(SCL)$	SDA and SCL fall time		300	$20 + 0.1C_b^{(2)}$	300	
$t_h(ST)$	START condition hold time	4		0.6		μ s
$t_{su(SR)}$	Repeated START condition setup time	4.7		0.6		
$t_{su(SP)}$	STOP condition setup time	4		0.6		
$t_w(SP:SR)$	Bus free time between STOP and START condition	4.7		1.3		

1. Data based on standard I²C protocol requirement, not tested in production.

2. C_b = total capacitance of one bus line, in pF.

Figure 3. I²C slave timing diagram (c)

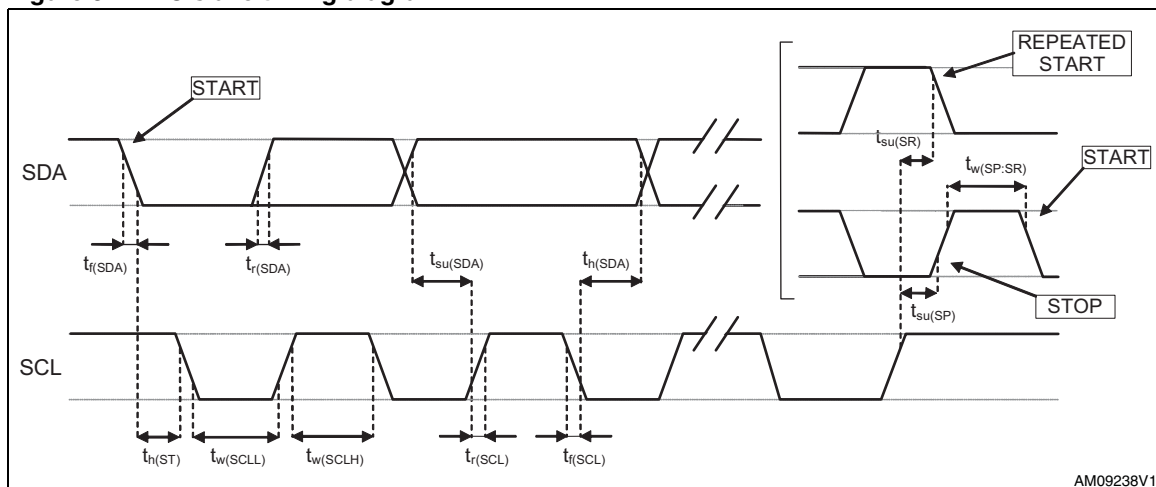

AM09238V1

2.5 Absolute maximum ratings

Stresses above those listed as “absolute maximum ratings” may cause permanent damage to the device. This is a stress rating only and functional operation of the device under these conditions is not implied. Exposure to maximum rating conditions for extended periods may affect device reliability.

Table 7. Absolute maximum ratings

Symbol	Ratings	Maximum value	Unit
V _{DD}	Supply voltage	-0.3 to 4.8	V
V _{DD_IO}	I/O pins supply voltage	-0.3 to 4.8	V
V _{IN}	Input voltage on any control pin (SCL, SDA)	-0.3 to V _{DD_IO} +0.3	V
A _{POW}	Acceleration (any axis, powered, V _{DD} = 2.5 V)	3,000 for 0.5 ms	<i>g</i>
		10,000 for 0.1 ms	<i>g</i>
A _{UNP}	Acceleration (any axis, unpowered)	3,000 for 0.5 ms	<i>g</i>
		10,000 for 0.1 ms	<i>g</i>
T _{OP}	Operating temperature range	-40 to +85	°C
T _{STG}	Storage temperature range	-40 to +125	°C



This is a mechanical shock sensitive device, improper handling can cause permanent damage to the part.



This is an ESD sensitive device, improper handling can cause permanent damage to the part.

c. Measurement points are done at 0.2·V_{DD_IO} and 0.8·V_{DD_IO}, for both ports.

2.6 Terminology

2.6.1 Linear acceleration sensitivity

Linear acceleration sensitivity describes the gain of the accelerometer sensor and can be determined by applying 1 *g* acceleration to it. As the sensor can measure DC accelerations, this can be done easily by pointing the axis of interest towards the center of the Earth, noting the output value, rotating the sensor by 180 degrees (pointing to the sky) and noting the output value again. By doing so, ± 1 *g* acceleration is applied to the sensor. Subtracting the larger output value from the smaller one, and dividing the result by 2, leads to the actual sensitivity of the sensor. This value changes very little over temperature and also very little over time. The sensitivity tolerance describes the range of sensitivities of a large population of sensors.

2.6.2 Zero-g level

Zero-*g* level offset (TyOff) describes the deviation of an actual output signal from the ideal output signal if no acceleration is present. A sensor in a steady-state on a horizontal surface measures 0 *g* in the X axis and 0 *g* in the Y axis whereas the Z axis measures 1 *g*. The output is ideally in the middle of the dynamic range of the sensor (content of OUT registers 00h, data expressed as 2's complement number). A deviation from the ideal value in this case is called Zero-*g* offset. Offset is, to some extent, a result of stress to the MEMS sensor and therefore the offset can slightly change after mounting the sensor onto a printed circuit board or exposing it to extensive mechanical stress. Offset changes little over temperature, see "Zero-*g* level change vs. temperature". The Zero-*g* level tolerance (TyOff) describes the standard deviation of the range of Zero-*g* levels of a population of sensors.

3 Functionality

The LSM303DLHC is a system-in-package featuring a 3D digital linear acceleration and 3D digital magnetic field detection sensor.

The system includes specific sensing elements and an IC interface capable of measuring both the linear acceleration and magnetic field applied on it and to provide a signal to the external world through an I²C serial interface with separated digital output.

The sensing system is manufactured using specialized micromachining processes, while the IC interfaces are realized using a CMOS technology that allows to design a dedicated circuit which is trimmed to better match the sensing element characteristics.

The LSM303DLHC features two data-ready signals (RDY) which indicate when a new set of measured acceleration data and magnetic data are available, therefore simplifying data synchronization in the digital system that uses the device.

The LSM303DLHC may also be configured to generate a free-fall interrupt signal according to a programmed acceleration event along the enabled axes.

Linear acceleration operating mode

LSM303DLHC provides two different acceleration operating modes, respectively reported as “normal mode” and “low-power mode”. While normal mode guarantees high resolution, low-power mode reduces further the current consumption.

[Table 8](#) summarizes how to select the operating mode.

Table 8. Accelerometer operating mode selection

Operating mode	CTRL_REG1[3] (LPen bit)	CTRL_REG4[3] (HR bit)	BW [Hz]	Turn-on time [ms]
Low-power mode	1	0	ODR/2	1
Normal mode	0	1	ODR/9	7/ODR

3.1 Factory calibration

The IC interface is factory calibrated for linear acceleration sensitivity (LA_So), and linear acceleration Zero-g level (LA_TyOff).

The trimming values are stored inside the device by a non-volatile memory. Any time the device is turned on, the trimming parameters are downloaded into the registers to be used during the normal operation. This allows the user to use the device without further calibration.

4 Application hints

Figure 4. LSM303DLHC electrical connection

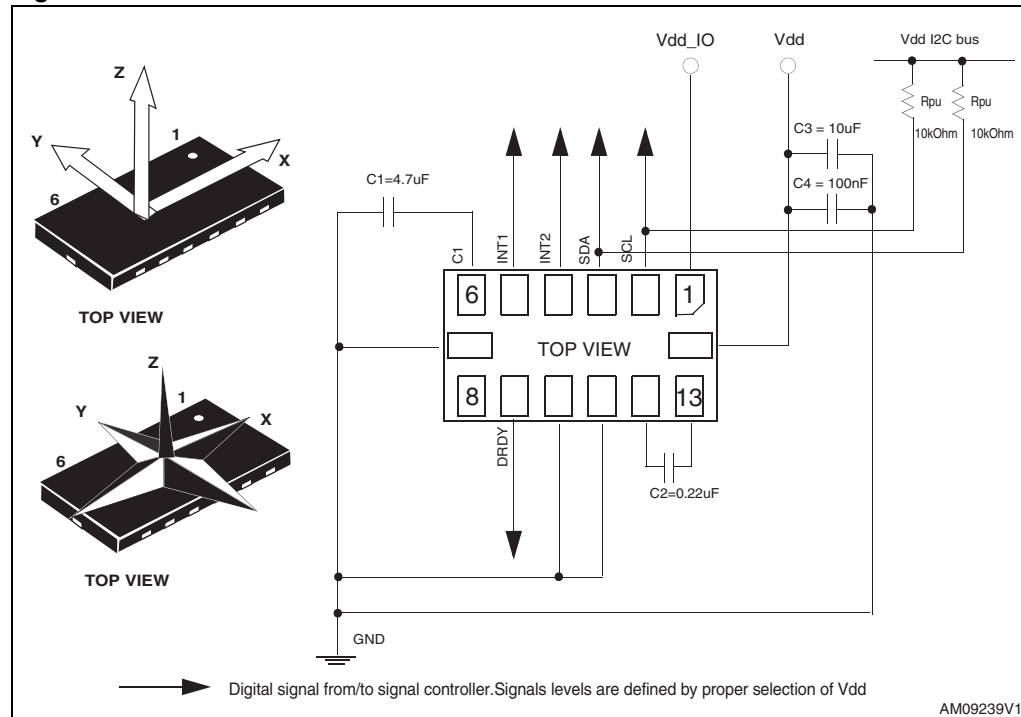

4.1 capacitors

The C1 and C2 external capacitors should be low SR value ceramic type constructions (typ. suggested value 200 mOhm). Reservoir capacitor C1 is nominally 4.7 μF in capacitance, with the set/reset capacitor C2 nominally 0.22 μF in capacitance.

The device core is supplied through the Vdd line. Power supply decoupling capacitors (C4=100 nF ceramic, C3=10 μF Al) should be placed as near as possible to the supply pin of the device (common design practice). All the voltage and ground supplies must be present at the same time to have proper behavior of the IC (refer to [Figure 4](#)).

The functionality of the device and the measured acceleration/magnetic field data is selectable and accessible through the I²C interface.

The functions, the threshold, and the timing of the two interrupt pins (INT 1 and INT 2) can be completely programmed by the user through the I²C interface.

4.2 Pull-up resistors

Pull-up resistors (suggested value 10 kOhm) are placed on the two I²C bus lines.

4.3 Digital interface power supply

This digital interface, dedicated to the linear acceleration and to the magnetic field signal, is capable of operating with a standard power supply (Vdd) or using a dedicated power supply (Vdd_IO).

4.4 Soldering information

The LGA package is compliant with the ECOPACK[®], RoHS, and “Green” standard. It is qualified for soldering heat resistance according to JEDEC J-STD-020.

Leave “Pin 1 Indicator” unconnected during soldering.

Land pattern and soldering recommendations are available at www.st.com/mems.

4.5 High current wiring effects

High current in the wiring and printed circuit trace can be culprits in causing errors in magnetic field measurements for compassing.

Conductor generated magnetic fields add to the Earth’s magnetic field, causing errors in compass heading computation.

Keep currents higher than 10 mA a few millimeters further away from the sensor IC.

5 Digital interfaces

The registers embedded inside the LSM303DLHC are accessible through two separate I²C serial interfaces, one for the accelerometer core and one for the magnetometer core.

Table 9. Serial interface pin description

PIN Name	PIN Description
SCL	I ² C serial clock (SCL)
SDA	I ² C serial data (SDA)

5.1 I²C serial interface

The LSM303DLHC I²C is a bus slave. The I²C is employed to write the data into the registers when also be read back.

The relevant I²C terminology is given in the table below.

Table 10. Serial interface pin description

Term	Description
Transmitter	The device which sends data to the bus
Receiver	The device which receives data from the bus
Master	The device which initiates a transfer, generates clock signals, and terminates a transfer
Slave	The device addressed by the master

There are two signals associated with the I²C bus, the serial clock line (SCL) and the serial data line (SDA). The latter is a bidirectional line used for sending and receiving the data to/from the interface.

5.1.1 I²C operation

The transaction on the bus is started through a START (ST) signal. A START condition is defined as a HIGH to LOW transition on the data line while the SCL line is held HIGH. After this has been transmitted by the master, the bus is considered busy. The next byte of data transmitted after the start condition contains the address of the slave in the first 7 bits and bit 8 tells whether the master is receiving data from the slave or transmitting data to the slave. When an address is sent, each device in the system compares the first seven bits after a start condition with its address. If they match, the device considers itself addressed by the master.

Data transfer with acknowledge is mandatory. The transmitter must release the SDA line during the acknowledge pulse. The receiver must then pull the data line LOW so that it remains stable low during the HIGH period of the acknowledge clock pulse. A receiver which has been addressed is obliged to generate an acknowledge after each byte of data received.

The I²C embedded inside the LSM303DLHC behaves like a slave device and the following protocol must be adhered to. After the start condition (ST) a slave address is sent, once a slave acknowledge (SAK) has been returned, an 8-bit sub-address (SUB) is transmitted; the 7 LSBs represent the actual register address while the MSB enables address auto-increment. If the MSB of the SUB field is '1', the SUB (register address) is automatically increased to allow multiple data Read/Write.

Table 11. Transfer when master is writing one byte to slave

Master	ST	SAD + W		SUB		DATA		SP
Slave			SAK		SAK		SAK	

Table 12. Transfer when master is writing multiple bytes to slave:

Master	ST	SAD + W		SUB		DATA		DATA		SP
Slave			SAK		SAK		SAK		SAK	

Table 13. Transfer when master is receiving (reading) one byte of data from slave:

Master	ST	SAD + W		SUB		SR	SAD + R			NMAK	SP
Slave			SAK		SAK			SAK	DATA		

Data are transmitted in byte format (DATA). Each data transfer contains 8 bits. The number of bytes transferred per transfer is unlimited. Data is transferred with the most significant bit (MSB) first. If a receiver can't receive another complete byte of data until it has performed some other function, it can hold the clock line SCL LOW to force the transmitter into a wait state. Data transfer only continues when the receiver is ready for another byte and releases the data line. If a slave receiver doesn't acknowledge the slave address (i.e. it is not able to receive because it is performing some real-time function) the data line must be left HIGH by the slave. The master can then abort the transfer. A LOW to HIGH transition on the SDA line while the SCL line is HIGH is defined as a STOP condition. Each data transfer must be terminated by the generation of a STOP (SP) condition.

5.1.2 Linear acceleration digital interface

For linear acceleration the default (factory) 7-bit slave address is 0011001b.

The slave address is completed with a Read/Write bit. If the bit is '1' (read), a repeated START (SR) condition must be issued after the two sub-address bytes; if the bit is '0' (write) the master transmits to the slave with the direction unchanged. [Table 14](#) explains how the read/write bit pattern is composed, listing all the possible configurations.

Table 14. SAD+Read/Write patterns

Command	SAD[7:1]	R/W	SAD+R/W
Read	0011001	1	00110011 (33h)
Write	0011001	0	00110010 (32h)

In order to read multiple bytes, it is necessary to assert the most significant bit of the sub-address field. In other words, SUB(7) must be equal to 1 while SUB(6-0) represents the address of the first register to be read.

In the presented communication format, MAK is master acknowledge and NMAK is no master acknowledge.

Table 15. Transfer when master is receiving (reading) multiple bytes of data from slave

Master	ST	SAD+W		SUB		SR	SAD+R			MAK		MAK		NMAK	SP
Slave			SAK		SAK			SAK	DATA		DATA		DATA		

5.1.3 Magnetic field digital interface

For magnetic sensors the default (factory) 7-bit slave address is 0011110xb.

The slave address is completed with a Read/Write bit. If the bit is '1' (read), a repeated START (SR) condition must be issued after the two sub-address bytes; if the bit is '0' (write) the master transmits to the slave with the direction unchanged. [Table 16](#) explains how the SAD is composed.

Table 16. SAD

Command	SAD[6:0]	R/W	SAD+R/W
Read	0011110	1	00111101 (3Dh)
Write	0011110	0	00111100 (3Ch)

Magnetic signal interface reading/writing

The interface uses an address pointer to indicate which register location is to be read from or written to. These pointer locations are sent from the master to this slave device and succeed the 7-bit address plus 1 bit Read/Write identifier.

To minimize the communication between the master and magnetic digital interface of LSM303DLHC, the address pointer updates automatically without master intervention.

This automatic address pointer update has two additional features. First, when address 12 or higher is accessed, the pointer updates to address 00, and secondly, when address 08 is reached, the pointer rolls back to address 03. Logically, the address pointer operation functions as shown below.

If (address pointer = 08) then the address pointer = 03

Or else, if (address pointer >= 12) then the address pointer = 0

Or else, (address pointer) = (address pointer) + 1

The address pointer value itself cannot be read via the I²C bus.

Any attempt to read an invalid address location returns 0, and any write to an invalid address location, or an undefined bit within a valid address location, is ignored by this device.

6 Register mapping

[Table 17](#) provides a listing of the 8-bit registers embedded in the device and the related addresses:

Table 17. Register address map

Name	Slave address	Type	Register address		Default	Comment
			Hex	Binary		
Reserved (do not modify)	Table 14		00 - 1F	--	--	Reserved
CTRL_REG1_A	Table 14	rw	20	010 0000	00000111	
CTRL_REG2_A	Table 14	rw	21	010 0001	00000000	
CTRL_REG3_A	Table 14	rw	22	010 0010	00000000	
CTRL_REG4_A	Table 14	rw	23	010 0011	00000000	
CTRL_REG5_A	Table 14	rw	24	010 0100	00000000	
CTRL_REG6_A	Table 14	rw	25	010 0101	00000000	
REFERENCE_A	Table 14	rw	26	010 0110	00000000	
STATUS_REG_A	Table 14	r	27	010 0111	00000000	
OUT_X_L_A	Table 14	r	28	010 1000	output	
OUT_X_H_A	Table 14	r	29	010 1001	output	
OUT_Y_L_A	Table 14	r	2A	010 1010	output	
OUT_Y_H_A	Table 14	r	2B	010 1011	output	
OUT_Z_L_A	Table 14	r	2C	010 1100	output	
OUT_Z_H_A	Table 14	r	2D	010 1101	output	
FIFO_CTRL_REG_A	Table 14	rw	2E	010 1110	00000000	
FIFO_SRC_REG_A	Table 14	r	2F	010 1111		
INT1_CFG_A	Table 14	rw	30	011 0000	00000000	
INT1_SOURCE_A	Table 14	r	31	011 0001	00000000	
INT1_THS_A	Table 14	rw	32	011 0010	00000000	
INT1_DURATION_A	Table 14	rw	33	011 0011	00000000	
INT2_CFG_A	Table 14	rw	34	011 0100	00000000	
INT2_SOURCE_A	Table 14	r	35	011 0101	00000000	
INT2_THS_A	Table 14	rw	36	011 0110	00000000	
INT2_DURATION_A	Table 14	rw	37	011 0111	00000000	
CLICK_CFG_A	Table 14	rw	38	011 1000	00000000	
CLICK_SRC_A	Table 14	rw	39	011 1001	00000000	
CLICK_THS_A	Table 14	rw	3A	011 1010	00000000	
TIME_LIMIT_A	Table 14	rw	3B	011 1011	00000000	

Table 17. Register address map (continued)

Name	Slave address	Type	Register address		Default	Comment
			Hex	Binary		
TIME_LATENCY_A	Table 14	rw	3C	011 1100	00000000	
TIME_WINDOW_A	Table 14	rw	3D	011 1101	00000000	
Reserved (do not modify)	Table 14		3E-3F	--	--	Reserved
CRA_REG_M	Table 16	rw	00	00000000	0001000	
CRB_REG_M	Table 16	rw	01	00000001	0010000	
MR_REG_M	Table 16	rw	02	00000010	00000011	
OUT_X_H_M	Table 16	r	03	00000011	output	
OUT_X_L_M	Table 16	r	04	00000100	output	
OUT_Z_H_M	Table 16	r	05	00000101	output	
OUT_Z_L_M	Table 16	r	06	00000110	output	
OUT_Y_H_M	Table 16	r	07	00000111	output	
OUT_Y_L_M	Table 16	r	08	00001000	output	
SR_REG_Mg	Table 16	r	09	00001001	00000000	
IRA_REG_M	Table 16	r	0A	00001010	01001000	
IRB_REG_M	Table 16	r	0B	00001011	00110100	
IRC_REG_M	Table 16	r	0C	00001100	00110011	
Reserved (do not modify)	Table 16		0D-30	--	--	Reserved
TEMP_OUT_H_M	Table 16		31	00000000	output	
TEMP_OUT_L_M	Table 16		32	00000000	output	
Reserved (do not modify)	Table 16		33-3A	--	--	Reserved

Registers marked as “reserved” must not be changed. The writing to these registers may cause permanent damage to the device.

The content of the registers that are loaded at boot should not be changed. They contain the factory calibrated values. Their content is automatically restored when the device is powered up.

7 Register description

The device contains a set of registers which are used to control its behavior and to retrieve acceleration data. The register address, made up of 7 bits, is used to identify them and to write the data through the serial interface.

7.1 Linear acceleration register description

7.1.1 CTRL_REG1_A (20h)

Table 18. CTRL_REG1_A register

ODR3	ODR2	ODR1	ODR0	LPen	Zen	Yen	Xen
------	------	------	------	------	-----	-----	-----

Table 19. CTRL_REG1_A description

ODR3-0	Data rate selection. Default value: 0 (0000: power-down, others: refer to Table 20 .)
LPen	Low-power mode enable. Default value: 0 (0: normal mode, 1: low-power mode)
Zen	Z axis enable. Default value: 1 (0: Z axis disabled, 1: Z axis enabled)
Yen	Y axis enable. Default value: 1 (0: Y axis disabled, 1: Y axis enabled)
Xen	X axis enable. Default value: 1 (0: X axis disabled, 1: X axis enabled)

ODR<3:0> is used to set the power mode and ODR selection. In [Table 20](#) all frequencies resulting in a combination of ODR<3:0> are listed.

Table 20. Data rate configuration

ODR3	ODR2	ODR1	ODR0	Power mode selection
0	0	0	0	Power-down mode
0	0	0	1	Normal / low-power mode (1 Hz)
0	0	1	0	Normal / low-power mode (10 Hz)
0	0	1	1	Normal / low-power mode (25 Hz)
0	1	0	0	Normal / low-power mode (50 Hz)
0	1	0	1	Normal / low-power mode (100 Hz)
0	1	1	0	Normal / low-power mode (200 Hz)
0	1	1	1	Normal / low-power mode (400 Hz)

Table 20. Data rate configuration (continued)

ODR3	ODR2	ODR1	ODR0	Power mode selection
1	0	0	0	Low-power mode (1.620 KHz)
1	0	0	1	Normal (1.344 kHz) / low-power mode (5.376 KHz)

7.1.2 CTRL_REG2_A (21h)

Table 21. CTRL_REG2_A register

HPM1	HPM0	HPCF2	HPCF1	FDS	HPCLICK	HPIS2	HPIS1
------	------	-------	-------	-----	---------	-------	-------

Table 22. CTRL_REG2_A description

HPM1 -HPM0	High pass filter mode selection. Default value: 00 (refer to Table 23)
HPCF2 - HPCF1	High pass filter cut-off frequency selection
FDS	Filtered data selection. Default value: 0 (0: internal filter bypassed, 1: data from internal filter sent to output register and FIFO)
HPCLICK	High pass filter enabled for CLICK function. (0: filter bypassed, 1: filter enabled)
HPIS2	High pass filter enabled for AOI function on Interrupt 2, (0: filter bypassed, 1: filter enabled)
HPIS1	High pass filter enabled for AOI function on Interrupt 1, (0: filter bypassed, 1: filter enabled)

Table 23. High pass filter mode configuration

HPM1	HPM0	High pass filter mode
0	0	Normal mode (reset reading HP_RESET_FILTER)
0	1	Reference signal for filtering
1	0	Normal mode
1	1	Autoreset on interrupt event

7.1.3 CTRL_REG3_A (22h)

Table 24. CTRL_REG3_A register

I1_CLICK	I1_AOI1	I1_AOI2	I1_DRDY1	I1_DRDY2	I1_WTM	I1_OVERRUN	--
----------	---------	---------	----------	----------	--------	------------	----

Table 25. CTRL_REG3_A description

I1_CLICK	CLICK interrupt on INT1. Default value 0. (0: disable, 1: enable)
I1_AOI1	AOI1 interrupt on INT1. Default value 0. (0: disable, 1: enable)
I1_AOI2	AOI2 interrupt on INT1. Default value 0. (0: disable, 1: enable)
I1_DRDY1	DRDY1 interrupt on INT1. Default value 0. (0: disable, 1: enable)
I1_DRDY2	DRDY2 interrupt on INT1. Default value 0. (0: disable, 1: enable)
I1_WTM	FIFO watermark interrupt on INT1. Default value 0. (0: disable, 1: enable)
I1_OVERRUN	FIFO overrun interrupt on INT1. Default value 0. (0: disable, 1: enable)

7.1.4 CTRL_REG4_A (23h)

Table 26. CTRL_REG4_A register

BDU	BLE	FS1	FS0	HR	0 ⁽¹⁾	0 ⁽¹⁾	SIM
-----	-----	-----	-----	----	------------------	------------------	-----

1. This bit must be set to '0' for correct working of the device.

Table 27. CTRL_REG4_A description

BDU	Block data update. Default value: 0 (0: continuous update, 1: output registers not updated until MSB and LSB reading)
BLE	Big/little endian data selection. Default value 0. (0: data LSB @ lower address, 1: data MSB @ lower address)
FS1-FS0	Full-scale selection. Default value: 00 (00: +/- 2G, 01: +/- 4G, 10: +/- 8G, 11: +/- 16G)
HR	High resolution output mode: Default value: 0 (0: high resolution disable, 1: high resolution enable)
SIM	SPI serial interface mode selection. Default value: 0 (0: 4-wire interface, 1: 3-wire interface).

7.1.5 CTRL_REG5_A (24h)

Table 28. CTRL_REG5_A register

BOOT	FIFO_EN	--	--	LIR_INT1	D4D_INT1	LIR_INT2	D4D_INT2
------	---------	----	----	----------	----------	----------	----------

Table 29. CTRL_REG5_A description

BOOT	Reboot memory content. Default value: 0 (0: normal mode, 1: reboot memory content)
FIFO_EN	FIFO enable. Default value: 0 (0: FIFO disable, 1: FIFO enable)
LIR_INT1	Latch interrupt request on INT1_SRC register, with INT1_SRC register cleared by reading INT1_SRC itself. Default value: 0. (0: interrupt request not latched, 1: interrupt request latched)
D4D_INT1	4D enable: 4D detection is enabled on INT1 when 6D bit on INT1_CFG is set to 1.
LIR_INT2	Latch interrupt request on INT2_SRC register, with INT2_SRC register cleared by reading INT2_SRC itself. Default value: 0. (0: interrupt request not latched, 1: interrupt request latched)
D4D_INT2	4D enable: 4D detection is enabled on INT2 when 6D bit on INT2_CFG is set to 1.

7.1.6 CTRL_REG6_A (25h)

Table 30. CTRL_REG6_A register

I2_CLICKen	I2_INT1	I2_INT2	BOOT_I1	P2_ACT	--	H_LACTIVE	--
------------	---------	---------	---------	--------	----	-----------	----

Table 31. CTRL_REG6_A description

I2_CLICKen	CLICK interrupt on PAD2. Default value 0. (0: disable, 1: enable)
I2_INT1	Interrupt 1 on PAD2. Default value 0. (0: disable, 1: enable)
I2_INT2	Interrupt 2 on PAD2. Default value 0. (0: disable, 1: enable)
BOOT_I1	Reboot memory content on PAD2. Default value: 0 (0: disable, 1: enable)
P2_ACT	Active function status on PAD2. Default value 0. (0: disable, 1: enable)
H_LACTIVE	Interrupt active high, low. Default value 0. (0: active high, 1: active low)

7.1.7 REFERENCE/DATACAPTURE_A (26h)

Table 32. REFERENCE_A register

Ref7	Ref6	Ref5	Ref4	Ref3	Ref2	Ref1	Ref0
------	------	------	------	------	------	------	------

Table 33. REFERENCE_A register description

Ref 7-Ref0	Reference value for interrupt generation. Default value: 0
------------	--

7.1.8 STATUS_REG_A (27h)**Table 34. STATUS_A register**

ZYXOR	ZOR	YOR	XOR	ZYXDA	ZDA	YDA	XDA
-------	-----	-----	-----	-------	-----	-----	-----

Table 35. STATUS_A register description

ZYXOR	X, Y, and Z axis data overrun. Default value: 0 (0: no overrun has occurred, 1: a new set of data has overwritten the previous ones)
ZOR	Z axis data overrun. Default value: 0 (0: no overrun has occurred, 1: a new data for the Z-axis has overwritten the previous one)
YOR	Y axis data overrun. Default value: 0 (0: no overrun has occurred, 1: a new data for the Y-axis has overwritten the previous one)
XOR	X axis data overrun. Default value: 0 (0: no overrun has occurred, 1: a new data for the X-axis has overwritten the previous one)
ZYXDA	X, Y, and Z axis new data available. Default value: 0 (0: a new set of data is not yet available, 1: a new set of data is available)
ZDA	Z axis new data available. Default value: 0 (0: a new data for the Z-axis is not yet available, 1: a new data for the Z-axis is available)
YDA	Y axis new data available. Default value: 0 (0: a new data for the Y-axis is not yet available, 1: a new data for the Y-axis is available)
XDA	X axis new data available. Default value: 0 (0: a new data for the X-axis is not yet available, 1: a new data for the X-axis is available)

7.1.9 OUT_X_L_A (28h), OUT_X_H_A (29h)

X-axis acceleration data. The value is expressed in 2's complement.

7.1.10 OUT_Y_L_A (2Ah), OUT_Y_H_A (2Bh)

Y-axis acceleration data. The value is expressed in 2's complement.

7.1.11 OUT_Z_L_A (2Ch), OUT_Z_H_A (2Dh)

Z-axis acceleration data. The value is expressed in 2's complement.

7.1.12 FIFO_CTRL_REG_A (2Eh)

Table 36. REFERENCE_A register

FM1	FM0	TR	FTH4	FTH3	FTH2	FTH1	FTH0
-----	-----	----	------	------	------	------	------

Table 37. REFERENCE_A register description

FM1-FM0	FIFO mode selection. Default value: 00 (see Table 38)
TR	Trigger selection. Default value: 0 0: trigger event linked to trigger signal on INT1 1: trigger event linked to trigger signal on INT2
FTH4:0	Default value: 0

Table 38. FIFO mode configuration

FM1	FM0	FIFO mode configuration
0	0	Bypass mode
0	1	FIFO mode
1	0	Stream mode
1	1	Trigger mode

7.1.13 FIFO_SRC_REG_A (2Fh)

Table 39. FIFO_SRC_A register

WTM	OVFN_FIFO	EMPTY	FSS4	FSS3	FSS2	FSS1	FSS0
-----	-----------	-------	------	------	------	------	------

7.1.14 INT1_CFG_A (30h)

Table 40. INT1_CFG_A register

AOI	6D	ZHIE/ ZUPE	ZLIE/ ZDOWNE	YHIE/ YUPE	YLIE/ YDOWNE	XHIE/ XUPE	XLIE/ XDOWNE
-----	----	---------------	-----------------	---------------	-----------------	---------------	-----------------

Table 41. INT1_CFG_A description

AOI	AND/OR combination of interrupt events. Default value: 0 (refer to Table 42)
6D	6-direction detection function enabled. Default value: 0 (refer to Table 42)
ZHIE/ ZUPE	Enable interrupt generation on Z high event or on direction recognition. Default value: 0 (0: disable interrupt request, 1: enable interrupt request)
ZLIE/ ZDOWNE	Enable interrupt generation on Z low event or on direction recognition. Default value: 0 (0: disable interrupt request, 1: enable interrupt request)

Table 41. INT1_CFG_A description (continued)

YHIE/ YUPE	Enable interrupt generation on Y high event or on direction recognition. Default value: 0 (0: disable interrupt request, 1: enable interrupt request.)
YLIE/ YDOWNE	Enable interrupt generation on Y low event or on direction recognition. Default value: 0 (0: disable interrupt request, 1: enable interrupt request.)
XHIE/ XUPE	Enable interrupt generation on X high event or on direction recognition. Default value: 0 (0: disable interrupt request, 1: enable interrupt request.)
XLIE/XDOWNE	Enable interrupt generation on X low event or on direction recognition. Default value: 0 (0: disable interrupt request, 1: enable interrupt request.)

Content of this register is loaded at boot. Write operation at this address is possible only after system boot.

Table 42. Interrupt mode

AOI	6D	Interrupt mode
0	0	OR combination of interrupt events
0	1	6-direction movement recognition
1	0	AND combination of interrupt events
1	1	6-direction position recognition

Difference between AOI-6D = '01' and AOI-6D = '11'.

AOI-6D = '01' is movement recognition. An interrupt is generated when orientation moves from unknown zone to known zone. The interrupt signal stays for a duration ODR.

AOI-6D = '11' is direction recognition. An interrupt is generated when orientation is inside a known zone. The interrupt signal stays until orientation is inside the zone.

7.1.15 INT1_SRC_A (31h)

Table 43. INT1_SRC_A register

0 ⁽¹⁾	IA	ZH	ZL	YH	YL	XH	XL
------------------	----	----	----	----	----	----	----

1. This bit must be set to '0' for correct working of the device.

Table 44. INT1_SRC_A description

IA	Interrupt active. Default value: 0 (0: no interrupt has been generated, 1: one or more interrupts have been generated)
ZH	Z high. Default value: 0 (0: no interrupt, 1: Z high event has occurred)
ZL	Z low. Default value: 0 (0: no interrupt, 1: Z low event has occurred)
YH	Y high. Default value: 0 (0: no interrupt, 1: Y high event has occurred)

Table 44. INT1_SRC_A description (continued)

YL	Y low. Default value: 0 (0: no interrupt, 1: Y low event has occurred)
XH	X high. Default value: 0 (0: no interrupt, 1: X high event has occurred)
XL	X low. Default value: 0 (0: no interrupt, 1: X low event has occurred)

Interrupt 1 source register. Read only register.

Reading at this address clears the INT1_SRC IA bit (and the interrupt signal on the INT 1 pin) and allows the refreshing of data in the INT1_SRC register if the latched option was chosen.

7.1.16 INT1_THS_A (32h)

Table 45. INT1_THS_A register

0 ⁽¹⁾	THS6	THS5	THS4	THS3	THS2	THS1	THS0
------------------	------	------	------	------	------	------	------

1. This bit must be set to '0' for correct working of the device.

Table 46. INT1_THS_A description

THS6 - THS0	Interrupt 1 threshold. Default value: 000 0000
-------------	--

7.1.17 INT1_DURATION_A (33h)

Table 47. INT1_DURATION_A register

0 ⁽¹⁾	D6	D5	D4	D3	D2	D1	D0
------------------	----	----	----	----	----	----	----

1. This bit must be set to '0' for correct working of the device.

Table 48. INT1_DURATION_A description

D6 - D0	Duration value. Default value: 000 0000
---------	---

D6 - D0 bits set the minimum duration of the Interrupt 1 event to be recognized. Duration steps and maximum values depend on the ODR chosen.

7.1.18 INT2_CFG_A (34h)

Table 49. INT2_CFG_A register

AOI	6D	ZHIE	ZLIE	YHIE	YLIE	XHIE	XLIE
-----	----	------	------	------	------	------	------

Table 50. INT2_CFG_A description

AOI	AND/OR combination of interrupt events. Default value: 0 (see Table 51)
6D	6-direction detection function enabled. Default value: 0 (refer to Table 51)
ZHIE	Enable interrupt generation on Z high event. Default value: 0 (0: disable interrupt request, 1: enable interrupt request on measured accel. value higher than preset threshold)
ZLIE	Enable interrupt generation on Z low event. Default value: 0 (0: disable interrupt request, 1: enable interrupt request on measured accel. value lower than preset threshold)
YHIE	Enable interrupt generation on Y high event. Default value: 0 (0: disable interrupt request, 1: enable interrupt request on measured accel. value higher than preset threshold)
YLIE	Enable interrupt generation on Y low event. Default value: 0 (0: disable interrupt request, 1: enable interrupt request on measured accel. value lower than preset threshold)
XHIE	Enable interrupt generation on X high event. Default value: 0 (0: disable interrupt request, 1: enable interrupt request on measured accel. value higher than preset threshold)
XLIE	Enable interrupt generation on X low event. Default value: 0 (0: disable interrupt request, 1: enable interrupt request on measured accel. value lower than preset threshold)

Table 51. Interrupt mode

AOI	6D	Interrupt mode
0	0	OR combination of interrupt events
0	1	6-direction movement recognition
1	0	AND combination of interrupt events
1	1	6-direction position recognition

Difference between AOI-6D = '01' and AOI-6D = '11'.

AOI-6D = '01' is movement recognition. An interrupt is generated when orientation moves from unknown zone to known zone. The interrupt signal stays for a duration ODR.

AOI-6D = '11' is direction recognition. An interrupt is generated when orientation is inside a known zone. The interrupt signal stays until orientation is inside the zone.

7.1.19 INT2_SRC_A (35h)

Table 52. INT2_SRC_A register

0 ⁽¹⁾	IA	ZH	ZL	YH	YL	XH	XL
------------------	----	----	----	----	----	----	----

1. This bit must be set to '0' for correct working of the device.

Table 53. INT2_SRC_A description

IA	Interrupt active. Default value: 0 (0: no interrupt has been generated, 1: one or more interrupts have been generated)
ZH	Z high. Default value: 0 (0: no interrupt, 1: Z high event has occurred)
ZL	Z low. Default value: 0 (0: no interrupt, 1: Z low event has occurred)
YH	Y high. Default value: 0 (0: no interrupt, 1: Y high event has occurred)
YL	Y low. Default value: 0 (0: no interrupt, 1: Y low event has occurred)
XH	X high. Default value: 0 (0: no interrupt, 1: X high event has occurred)
XL	X Low. Default value: 0 (0: no interrupt, 1: X low event has occurred)

Interrupt 2 source register. Read only register.

Reading at this address clears INT2_SRC IA bit (and the interrupt signal on the INT 2 pin) and allows the refreshing of data in the INT2_SRC register if the latched option was chosen.

7.1.20 INT2_THS_A (36h)

Table 54. INT2_THS_A register

0 ⁽¹⁾	THS6	THS5	THS4	THS3	THS2	THS1	THS0
------------------	------	------	------	------	------	------	------

1. This bit must be set to '0' for correct working of the device

Table 55. INT2_THS_A description

THS6 - THS0	Interrupt 1 threshold. Default value: 000 0000
-------------	--

7.1.21 INT2_DURATION_A (37h)

Table 56. INT2_DURATION_A register

0 ⁽¹⁾	D6	D5	D4	D3	D2	D1	D0
------------------	----	----	----	----	----	----	----

1. This bit must be set to '0' for correct working of the device

Table 57. INT2_DURATION_A description

D6-D0	Duration value. Default value: 000 0000
-------	---

D6 - D0 bits set the minimum duration of the Interrupt 2 event to be recognized. Duration time steps and maximum values depend on the ODR chosen.

7.1.22 CLICK_CFG_A (38h)

Table 58. CLICK_CFG_A register

--	--	ZD	ZS	YD	YS	XD	XS
----	----	----	----	----	----	----	----

Table 59. CLICK_CFG_A description

ZD	Enable interrupt double CLICK on Z axis. Default value: 0 (0: disable interrupt request, 1: enable interrupt request on measured accel. value higher than preset threshold)
ZS	Enable interrupt single CLICK on Z axis. Default value: 0 (0: disable interrupt request, 1: enable interrupt request on measured accel. value higher than preset threshold)
YD	Enable interrupt double CLICK on Y axis. Default value: 0 (0: disable interrupt request, 1: enable interrupt request on measured accel. value higher than preset threshold)
YS	Enable interrupt single CLICK on Y axis. Default value: 0 (0: disable interrupt request, 1: enable interrupt request on measured accel. value higher than preset threshold)
XD	Enable interrupt double CLICK on X axis. Default value: 0 (0: disable interrupt request, 1: enable interrupt request on measured accel. value higher than preset threshold)
XS	Enable interrupt single CLICK on X axis. Default value: 0 (0: disable interrupt request, 1: enable interrupt request on measured accel. value higher than preset threshold)

7.1.23 CLICK_SRC_A (39h)

Table 60. CLICK_SRC_A register

--	IA	DCLICK	SCLICK	Sign	Z	Y	X
----	----	--------	--------	------	---	---	---

Table 61. CLICK_SRC_A description

IA	Interrupt active. Default value: 0 (0: no interrupt has been generated, 1: one or more interrupts have been generated)
DCLICK	Double CLICK-CLICK enable. Default value: 0 (0:double CLICK-CLICK detection disable, 1: double CLICK-CLICK detection enable)
SCLICK	Single CLICK-CLICK enable. Default value: 0 (0:Single CLICK-CLICK detection disable, 1: single CLICK-CLICK detection enable)
Sign	CLICK-CLICK Sign. 0: positive detection, 1: negative detection

Table 61. CLICK_SRC_A description (continued)

Z	Z CLICK-CLICK detection. Default value: 0 (0: no interrupt, 1: Z high event has occurred)
Y	Y CLICK-CLICK detection. Default value: 0 (0: no interrupt, 1: Y high event has occurred)
X	X CLICK-CLICK detection. Default value: 0 (0: no interrupt, 1: X high event has occurred)

7.1.24 CLICK_THS_A (3Ah)**Table 62. CLICK_THS_A register**

--	Ths6	Ths5	Ths4	Ths3	Ths2	Ths1	Ths0
----	------	------	------	------	------	------	------

Table 63. CLICK_SRC_A description

Ths6-Ths0	CLICK-CLICK threshold. Default value: 000 0000
-----------	--

1 LSB = full-scale / 128. THS6 through THS0 define the threshold which is used by the system to start the click detection procedure. The threshold value is expressed over 7 bits as an unsigned number.

7.1.25 TIME_LIMIT_A (3Bh)**Table 64. TIME_LIMIT_A register**

--	TLI6	TLI5	TLI4	TLI3	TLI2	TLI1	TLI0
----	------	------	------	------	------	------	------

Table 65. TIME_LIMIT_A description

TLI7-TLI0	CLICK-CLICK time limit. Default value: 000 0000
-----------	---

1 LSB = 1/ODR. TLI7 through TLI0 define the maximum time interval that can elapse between the start of the click detection procedure (the acceleration on the selected channel exceeds the programmed threshold) and when the acceleration goes back below the threshold.

7.1.26 TIME_LATENCY_A (3Ch)**Table 66. TIME_LATENCY_A register**

TLA7	TLA6	TLA5	TLA4	TLA3	TLA2	TLA1	TLA0
------	------	------	------	------	------	------	------

Table 67. TIME_LATENCY_A description

TLA7-TLA0	CLICK-CLICK time latency. Default value: 000 0000
-----------	---

1 LSB = 1/ODR. TLA7 through TLA0 define the time interval that starts after the first click detection where the click detection procedure is disabled, in cases where the device is configured for double click detection.

7.1.27 TIME_WINDOW_A (3Dh)

Table 68. TIME_WINDOW_A register

TW7	TW6	TW5	TW4	TW3	TW2	TW1	TW0
-----	-----	-----	-----	-----	-----	-----	-----

Table 69. TIME_WINDOW_A description

TW7-TW0	CLICK-CLICK time window
---------	-------------------------

1 LSB = 1/ODR. TW7 through TW0 define the maximum interval of time that can elapse after the end of the latency interval in which the click detection procedure can start, in cases where the device is configured for double click detection.

7.2 Magnetic field sensing register description

7.2.1 CRA_REG_M (00h)

Table 70. CRA_REG_M register

TEMP_EN	0 ⁽¹⁾	0 ⁽¹⁾	DO2	DO1	DO0	0 ⁽¹⁾	0 ⁽¹⁾
---------	------------------	------------------	-----	-----	-----	------------------	------------------

1. This bit must be set to '0' for correct working of the device

Table 71. CRA_REG_M description

TEMP_EN	Temperature sensor enable. 0: temperature sensor disabled (default), 1: temperature sensor enabled
DO2 to DO0	Data output rate bits. These bits set the rate at which data is written to all three data output registers (refer to Table 72). Default value: 100

Table 72. Data rate configurations

DO2	DO1	DO0	Minimum data output rate (Hz)
0	0	0	0.75
0	0	1	1.5
0	1	0	3.0
0	1	1	7.5
1	0	0	15
1	0	1	30

Table 72. Data rate configurations (continued)

DO2	DO1	DO0	Minimum data output rate (Hz)
1	1	0	75
1	1	1	220

7.2.2 CRB_REG_M (01h)**Table 73. CRA_REG register**

GN2	GN1	GN0	0 ⁽¹⁾	0 ⁽¹⁾	0 ⁽¹⁾	0 ⁽¹⁾	0 ⁽¹⁾

1. This bit must be set to '0' for correct working of the device.

Table 74. CRA_REG description

GN1-0	Gain configuration bits. The gain configuration is common for all channels (refer to Table 75)
-------	---

Table 75. Gain setting

GN2	GN1	GN0	Sensor input field range [Gauss]	Gain X, Y, and Z [LSB/Gauss]	Gain Z [LSB/Gauss]	Output range
0	0	1	±1.3	1100	980	0xF800–0x07FF (-2048–2047)
0	1	0	±1.9	855	760	
0	1	1	±2.5	670	600	
1	0	0	±4.0	450	400	
1	0	1	±4.7	400	355	
1	1	0	±5.6	330	295	
1	1	1	±8.1	230	205	

7.2.3 MR_REG_M (02h)**Table 76. MR_REG**

0 ⁽¹⁾	0 ⁽¹⁾	0 ⁽¹⁾	0 ⁽¹⁾	0 ⁽¹⁾	0 ⁽¹⁾	MD1	MD0

1. This bit must be set to '0' for correct working of the device.

Table 77. MR_REG description

MD1-0	Mode select bits. These bits select the operation mode of this device (refer to Table 78)
-------	--

Table 78. Magnetic sensor operating mode

MD1	MD0	Mode
0	0	Continuous-conversion mode
0	1	Single-conversion mode
1	0	Sleep-mode. Device is placed in sleep-mode
1	1	Sleep-mode. Device is placed in sleep-mode

7.2.4 OUT_X_H_M (03), OUT_X_LH_M (04h)

X-axis magnetic field data. The value is expressed as 2's complement.

7.2.5 OUT_Z_H_M (05), OUT_Z_L_M (06h)

Z-axis magnetic field data. The value is expressed as 2's complement.

7.2.6 OUT_Y_H_M (07), OUT_Y_L_M (08h)

Y-axis magnetic field data. The value is expressed as 2's complement.

7.2.7 SR_REG_M (09h)**Table 79. SR register**

--	--	--	--	--	--	LOCK	DRDY
----	----	----	----	----	----	------	------

Table 80. SR register description

LOCK	Data output register lock. Once a new set of measurements is available, this bit is set when the first magnetic field data register has been read.
DRDY	Data ready bit. This bit is set when a new set of measurements are available.

7.2.8 IR_REG_M (0Ah/0Bh/0Ch)**Table 81. IRA_REG_M**

0	1	0	0	1	0	0	0
---	---	---	---	---	---	---	---

Table 82. IRB_REG_M

0	0	1	1	0	1	0	0
---	---	---	---	---	---	---	---

Table 83. IRC_REG_M

0	0	1	1	0	0	1	1
---	---	---	---	---	---	---	---

7.2.9 TEMP_OUT_H_M (31h), TEMP_OUT_L_M (32h)

Table 84. TEMP_OUT_H_M register

TEMP11	TEMP10	TEMP9	TEMP8	TEMP7	TEMP6	TEMP5	TEMP4
--------	--------	-------	-------	-------	-------	-------	-------

Table 85. TEMP_OUT_L_M register

TEMP3	TEMP2	TEMP1	TEMP0	--	--	--	--
-------	-------	-------	-------	----	----	----	----

Table 86. TEMP_OUT resolution

TEMP11-0	Temperature data (8LSB/deg - 12-bit resolution). The value is expressed as 2's complement.
----------	--

8 Package information

In order to meet environmental requirements, ST offers these devices in different grades of ECOPACK® packages, depending on their level of environmental compliance. ECOPACK specifications, grade definitions, and product status are available at: www.st.com. ECOPACK is an ST trademark.

Figure 5. LGA-14: mechanical data and package dimensions

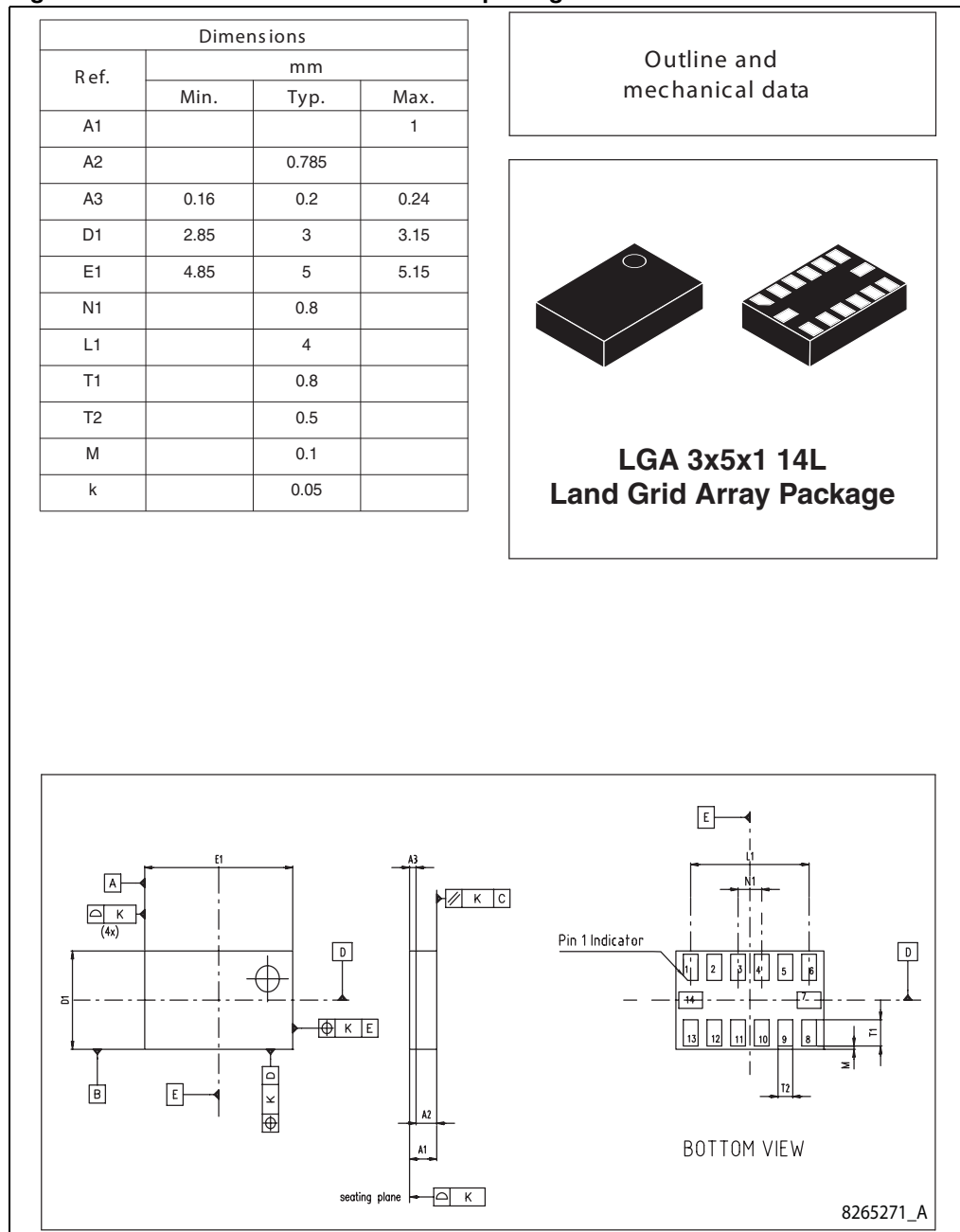

9 Revision history

Table 87. Document revision history

Date	Revision	Changes
21-Apr-2011	1	Initial release.

Please Read Carefully:

Information in this document is provided solely in connection with ST products. STMicroelectronics NV and its subsidiaries ("ST") reserve the right to make changes, corrections, modifications or improvements, to this document, and the products and services described herein at any time, without notice.

All ST products are sold pursuant to ST's terms and conditions of sale.

Purchasers are solely responsible for the choice, selection and use of the ST products and services described herein, and ST assumes no liability whatsoever relating to the choice, selection or use of the ST products and services described herein.

No license, express or implied, by estoppel or otherwise, to any intellectual property rights is granted under this document. If any part of this document refers to any third party products or services it shall not be deemed a license grant by ST for the use of such third party products or services, or any intellectual property contained therein or considered as a warranty covering the use in any manner whatsoever of such third party products or services or any intellectual property contained therein.

UNLESS OTHERWISE SET FORTH IN ST'S TERMS AND CONDITIONS OF SALE ST DISCLAIMS ANY EXPRESS OR IMPLIED WARRANTY WITH RESPECT TO THE USE AND/OR SALE OF ST PRODUCTS INCLUDING WITHOUT LIMITATION IMPLIED WARRANTIES OF MERCHANTABILITY, FITNESS FOR A PARTICULAR PURPOSE (AND THEIR EQUIVALENTS UNDER THE LAWS OF ANY JURISDICTION), OR INFRINGEMENT OF ANY PATENT, COPYRIGHT OR OTHER INTELLECTUAL PROPERTY RIGHT.

UNLESS EXPRESSLY APPROVED IN WRITING BY AN AUTHORIZED ST REPRESENTATIVE, ST PRODUCTS ARE NOT RECOMMENDED, AUTHORIZED OR WARRANTED FOR USE IN MILITARY, AIR CRAFT, SPACE, LIFE SAVING, OR LIFE SUSTAINING APPLICATIONS, NOR IN PRODUCTS OR SYSTEMS WHERE FAILURE OR MALFUNCTION MAY RESULT IN PERSONAL INJURY, DEATH, OR SEVERE PROPERTY OR ENVIRONMENTAL DAMAGE. ST PRODUCTS WHICH ARE NOT SPECIFIED AS "AUTOMOTIVE GRADE" MAY ONLY BE USED IN AUTOMOTIVE APPLICATIONS AT USER'S OWN RISK.

Resale of ST products with provisions different from the statements and/or technical features set forth in this document shall immediately void any warranty granted by ST for the ST product or service described herein and shall not create or extend in any manner whatsoever, any liability of ST.

ST and the ST logo are trademarks or registered trademarks of ST in various countries.

Information in this document supersedes and replaces all information previously supplied.

The ST logo is a registered trademark of STMicroelectronics. All other names are the property of their respective owners.

© 2011 STMicroelectronics - All rights reserved

STMicroelectronics group of companies

Australia - Belgium - Brazil - Canada - China - Czech Republic - Finland - France - Germany - Hong Kong - India - Israel - Italy - Japan - Malaysia - Malta - Morocco - Philippines - Singapore - Spain - Sweden - Switzerland - United Kingdom - United States of America

www.st.com