



### DUO-TOUCH SG Two-Hand Control Module Features

- Diverse-redundant microcontrollers
- Module supplies power and monitors two Banner STB Self-Checking Optical Touch Buttons, or two mechanical push buttons
- Two redundant, forced-guided (mechanically linked) output contacts rated at 6 A
- Two auxiliary solid-state outputs (NPN and PNP), plus auxiliary N.C. relay output
- Feedback input for monitoring external machine control elements
- Seven indicator LEDs for Power, Fault, Input 1, Input 2, SSI, Mute, and Output
- 24V dc, 115V ac or 24V dc, 230V ac operation, depending on model
- DIN-rail-mountable 67.5-mm-wide housing with removable terminal blocks
- 500 ms (max.) simultaneity requirement for touch-/push-button operation
- Two mute inputs allow release of actuating buttons during the non-hazardous portion of the machine cycle.
- Safety Stop Interface (SSI) allows for connection of supplemental safeguards, E-stop, “Top” stop or anti-repeat devices, or the output of a brake monitor.

### DUO-TOUCH SG Safety Module Description

A DUO-TOUCH SG Two-Hand Control Safety Module may be used with:

- Two Banner STB Self-Checking Optical Touch Buttons, each with one normally open and one normally closed relay output contact, or
- Two Banner STB Self-Checking Optical Touch Buttons, each with two current-sourcing PNP outputs, or
- Two mechanical push buttons with one normally open and one normally closed contact each (Form C contact)

If the machine operator removes one or both hands from the actuating device(s), the Duo-Touch SG relays de-energize, causing the output contacts to open. The relays will not re-energize until both actuating devices are deactivated and then simultaneously reactivated (SSI input channels closed).

**The Duo-Touch SG Two-Hand Control system has been designed to meet:**

- Type IIIC requirements of ISO 13851 (EN 574) Safety of Machinery – Two-Hand Control Devices, and
- Category 4 requirements of ISO 13849-1 (EN 954-1) Safety of Machinery – Safety-Related Parts of Control Systems – Part 1: General Principles of Design

The Safety Module’s output signal consists of two sets of redundant, forced-guided (mechanically linked) contacts (see Figures on page 10). Circuitry within the Safety Module monitors these internal contacts and prevents an output signal from occurring if a fault is detected. A feedback loop is offered for monitoring the status of the machine control elements.



#### **WARNING ... Point-of-Operation Guarding**

When properly installed, the DUO-TOUCH SG Two-Hand Control Safety Module provides protection only for the hands of the machine operator. It may be necessary to install additional safeguarding, such as safety light screens and/or hard guards, to protect personnel from hazardous machinery.

**Failure to properly guard hazardous machinery can result in a dangerous condition which could lead to serious injury or death.**

# DUO-TOUCH® SG – Models AT-GM-11KM and AT-HM-11KM Two-Hand Control Modules



## Important ... read this page before proceeding!

In the United States, the functions that the Banner DUO-TOUCH SG Two-Hand Control Module is intended to perform are regulated by the Occupational Safety and Health Administration (OSHA). Whether or not any particular DUO-TOUCH SG Two-Hand Control Module installation meets all applicable OSHA requirements depends upon factors that are beyond the control of Banner Engineering Corp. These factors include the specific ways the safety module is applied, installed, wired, operated, and maintained.

Banner Engineering Corp. has attempted to provide complete application, installation, operation, and maintenance instructions. In addition, we suggest that any questions regarding the use or installation of this two-hand control safety system be directed to the factory applications department at the telephone numbers or address shown on the back cover of this manual.

The user of this Two-Hand Control safety module must ensure that all machine operators, maintenance personnel, electricians, and supervisors are thoroughly familiar with and understand all instructions regarding the installation, maintenance, and use of this system, and with the machinery upon which it is installed.

The user and any personnel involved with the installation and use of this safety module must be thoroughly familiar with all applicable OSHA regulations and ANSI standards. The regulations and standards, listed below, directly address the use of two-hand control systems. Banner Engineering Corp. makes no claim regarding a specific recommendation of any organization, the accuracy or effectiveness of any information provided, or the appropriateness of the provided information for a specific application.

The user has the responsibility to ensure that all local, state, and national laws, rules, codes, and regulations relating to the use of this Two-Hand Control module are satisfied. Extreme care is urged that all legal requirements are met and that all installation and maintenance instructions contained in this manual are followed.

### U. S. Standards Applicable to Use of Two-Hand Control Systems

ANSI B11 Available from:	Standards for Machine Tools "Safety Requirements for the Construction, Care and Use" Safety Director AMT – The Association for Manufacturing Technology 7901 Westpark Drive McLean, VA 22102 Tel.: 703-893-2900 Fax: 703-893-1151
NFPA79 Available from:	"Electrical Standard for Industrial Machinery" National Fire Protection Association 1 Batterymarch Park, P.O. Box 9101 Quincy, MA 02269-9101 Tel.: 800-344-3555
ANSI/RIA R15.06 Available from:	"Safety Requirements for Industrial Robots and Robot Systems" Robotic Industries Association 900 Victors Way, P.O. Box 3724 Ann Arbor, MI 48106 Tel.: 734-994-6088

### International Standards Applicable to Use of Two-Hand Control Systems

ISO/TR12100-1 & -2 (EN292-1 & -2)	"Safety of Machinery – Basic Concepts, General Principles for Design, Part 1: Basic Terminology, Methodology" Part 2: Technical Principles and Specifications"
IEC/EN60204-1	"Electrical Equipment of Machines: Part 1: General Requirements" Also, request a type "C" standard for your specific machinery.
ISO13849-1 (EN954-1)	"Safety of Machinery – Safety Related Parts of Control Systems"
ISO13855 (EN999)	"Safety of Machinery – The Positioning of Protective Equipment"
ISO13851 (EN574)	"Safety of Machinery – Two-Hand Control Devices"
Available from:	Global Engineering Documents 15 Inverness Way East Englewood, CO 80112-5704 Tel.: 800-854-7179

# DUO-TOUCH® SG – Models AT-GM-11KM and AT-HM-11KM Two-Hand Control Modules

## Appropriate Applications

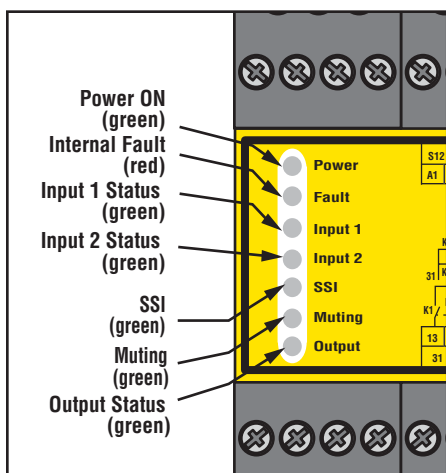

Figure 1. AT-..M-11KM status indicators

The DUO-TOUCH SG Two-Hand Control Safety Module may be used as an initiation device for most powered machinery when machine cycling is controlled by a machine operator.

Using a two-hand control system makes the operator a “hostage” while the hazard is present, thus limiting or preventing exposure to the hazard. The two-hand control actuators must be located in a way that hazardous motion is completed or stopped before the operator can release one or both of the buttons and reach the hazard (see **Separation Distance** on page 8).

Simultaneous use of both hands is required, meaning that both buttons must be actuated within a very short time span. The time span is specified by ANSI/RIA R15.06, ANSI/NFPA79, and ISO 13851 (EN 574) as not more than 500 ms, even under single-fault conditions. This requirement reduces the possibility of intentional defeat and unintended initiation of the machine cycle.

When used in single-cycle or single-stroke mode, the machine control must provide an anti-repeat feature so that the operator must release the two-hand control actuators after each machine cycle, before a new cycle can be initiated. In addition to the anti-repeat of the machine control, the mute inputs (M1 and M2), the Safety Stop Interface (SSI), or Backdoor Timer also may be used to halt a machine cycle (see Caution at left).

The actuating devices must be protected from accidental or unintended operation. This can be accomplished by their mounting position and/or through the use of protective shields such as rings, guards or shields; see Figure 7.

NOTE: Two-hand control and two-hand trip safeguarding protect *only the operator's hands*. Additional safeguarding may be required. The user must refer to the relevant standards for additional requirements for the application of two-hand control and two-hand trip devices when used for safeguarding.

“Muting” of the two-hand control can only occur during a non-hazardous portion of the machine cycle. When the hand controls are muted, the operator’s hands may be removed from the devices, but the Safety Module’s outputs remain closed.

A mute cycle can be initiated after the Safety Stop Interface (SSI) is closed and the two-hand control buttons are activated. After the Mute Enable input closes, M1 and M2 can close (within the 3-second simultaneity requirement), then the Module will start a mute cycle, light the mute lamp, and latch the outputs ON. The outputs will remain ON until M1 or M2 opens, the SSI opens, the backdoor timer expires, a lockout occurs, or the Module loses power.

### Part-Revolution Clutched Machinery

A two-hand control safety module can be used for the following functions: “inch” (jog), “single-stroke,” or “continuous” (run). Two-hand control safety modules are recognized as a means of protecting the machine operator when the hand controls are safely located and protected from false operation (see **Mechanical Installation** on page 7 and **Separation Distance** on page 8) and when properly interfaced to the machine (see **Electrical Installation** on page 8) to control the required stopping action.

### Full-Revolution Clutched Machinery

A two-hand control safety module used to initiate the cycle of a full-revolution clutched machine is known as a “two-hand trip device.” Two-hand trip devices are recognized as a means of protecting the machine operator when the hand controls are safely located and protected from false operation (see **Mechanical Installation** on page 7 and **Separation Distance** on page 8) and when properly interfaced to the machine (see **Electrical Installation** on page 8) to prevent accidental cycle initiation.



### CAUTION ... Machine Control Must Provide Anti-Repeat Control

Appropriate anti-repeat control must be provided by the machine control and is required by U.S. and International standards for single-stroke or single-cycle machines.

The AT-..M-11KM DUO-TOUCH SG Two-Hand Control Safety Module can be used to assist in accomplishing anti-repeat control, but a risk assessment must be accomplished to determine the suitability of such use.



### WARNING ... Muting Limitations

Muting is allowed only during the non-hazardous portion of the machine cycle.

A muting application must be designed in such a manner that the level of integrity of the safety system to be muted is not reduced.

# DUO-TOUCH® SG – Models AT-GM-11KM and AT-HM-11KM Two-Hand Control Modules

## Theory of Operation

The input circuit of the DUO-TOUCH SG Safety Module requires simultaneous actuation (within 0.5 seconds of each other) of both two-hand control actuators to generate an output signal.

The timing diagram in Figure 2 illustrates that an output signal from the DUO-TOUCH SG Safety Module occurs only if switches #1 and #2 (SW1 and SW2) are actuated within 0.5 seconds of each other. The output signal drops within 35 milliseconds following the release of either switch. The device output does not reenergize until both hand controls are disengaged, and then simultaneously re-actuated. This logic reduces the possibility of defeating the two-hand control system by tying down one or both actuators.

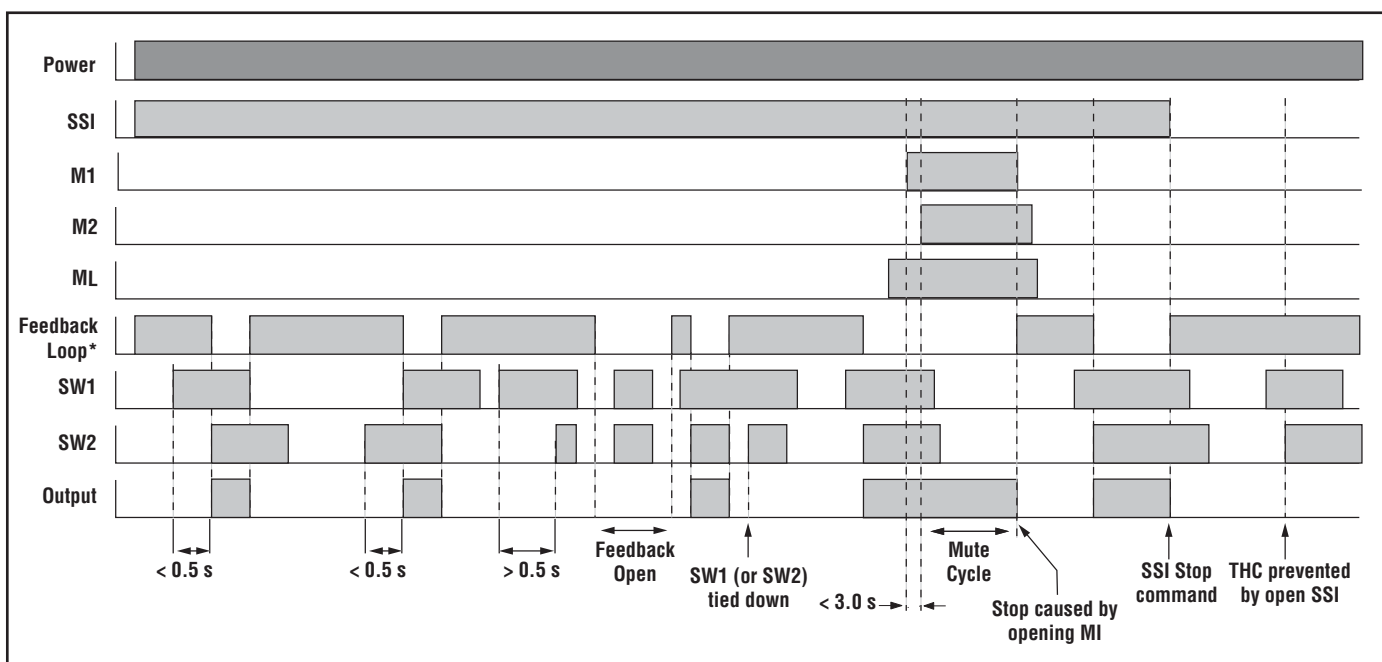

Figure 2. DUO-TOUCH SG Safety Module AT-..M-13A timing diagram

### Muting M1 and M2 Inputs

“Muting” is the automatic suspension of the safeguarding function of a safety device during a non-hazardous portion of the machine cycle.

To mute the two-hand control buttons appropriately, the muting system’s design must:

- 1) Identify the non-hazardous portion of the machine cycle,
- 2) Involve the selection of the proper muting devices, and
- 3) Include proper mounting and installation of those devices.

The M1 and M2 muting devices must have normally open contacts, or one device with a PNP output and one device with an NPN output. Both devices must fulfill certain input requirements (see Muting Device Inputs in the Safety Module Specifications table). Several types of devices may be used, including (but not limited to): limit switches, photoelectric sensors (opposed or polarized-retroreflective), positive-driven safety switches, and inductive proximity sensors.



**CAUTION ...**  
Do Not Use a Single Muting Device

A single device, such as one relay or one switch with two N.O. output contacts, may fail due to a single fault. Such a fault could result in an unintentional mute cycle and cause an unsafe situation.



## WARNING ... Avoid Hazardous Installations

Two independent position switches (at M1-M2) must be properly adjusted or positioned so they close only after the hazard no longer exists and open when the cycle is complete or the hazard is again present. If improperly adjusted or positioned, injury or death could result.

The user has the responsibility to satisfy all local, state, and national laws, rules codes, and regulations relating to the use of safety equipment in any application. It is extremely important to be sure that all appropriate agency requirements have been met and that all installation and maintenance instructions contained in the appropriate manuals are followed.

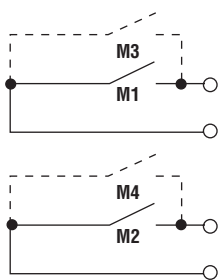

If two pairs of mute sensors are required, parallel the output (hard) contacts of M1 and M3, and M2 and M4, as shown above.

Figure 3. Hook-up of two pairs of mute devices

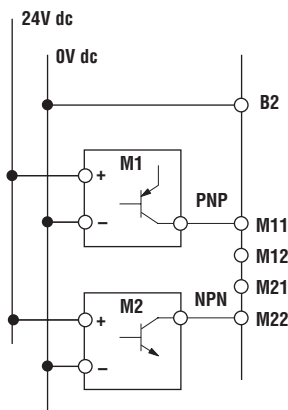

If solid-state output mute devices are required, use only devices with a discrete output, as shown above. Two-wire sensors should not be used due to the possibility of excessive leakage current causing a false ON condition.

Figure 4. Solid-state output hook-up

## Muting Device Requirements

The muting devices (typically sensors or switches) must, at a minimum, comply with the following requirements:

- A minimum of two independent hard-wired muting devices must be used. If the sources disagree or conflict, the mute must end or must not occur. No one source can initiate or continue a muted condition.
- The muting devices either must both have normally open contacts, or one device have a PNP output and one device have an NPN output. These contacts must “close” when the switch is actuated (to initiate a mute cycle), and “open” when the switch is not actuated (to end a mute cycle) and in a power off condition.
- The activation of the inputs to the muting module must be from separate sources. These sources must be mounted separately in order to prevent misadjustment or a single common mode failure resulting in an unintended muting condition. For example, this condition could cause physical damage to the mounting surface, causing both muting devices to be knocked out of alignment, resulting in false “muting” signals. Only one of these sources may pass through, or be affected by, a programmable logic controller or similar device.
- The devices must be installed so they can not be easily defeated or bypassed.
- The devices must be mounted so their physical position and alignment cannot change.
- It must not be possible for environmental conditions (such as extreme airborne contamination) to initiate a mute condition.
- The muting sensors or switches must not be set to use any delay or other timing functions (unless accomplished in such a manner that does not lessen the level of safety integrity of the system and does not create a hazard by extending the mute cycle).

## Examples of Muting Sensors and Switches

### Photoelectric Sensors (Opposed Mode):

Opposed-mode sensors, which initiate the muted condition when the beam path is blocked, should be configured for Dark Operate and have open (non-conducting) output contacts in a power OFF condition.

### Photoelectric Sensors (Polarized Retroreflective Mode):

The user must ensure that false “proxing” (activation due to shiny or reflective surfaces) is not possible. Banner “LP” sensors with linear polarization can greatly reduce or eliminate this effect.

Configure sensors for Light Operate (LO or N.O.) if initiating a mute when the retroreflective target or tape is detected (e.g., home position). Configure sensors for Dark Operate (DO or N.C.) when a blocked beam path initiates the muted condition (e.g., entry/exit). Both situations must have open (non-conducting) output contacts in a power OFF condition.

### Positive-Opening Safety Switches:

Two or four independent switches, each with a minimum of one closed safety contact to initiate the mute cycle are typically used. *An application using a single switch with a single actuator and two closed contacts could result in an unsafe situation.*

### Inductive Proximity Sensors:

Typically used to initiate a muted cycle when a metal surface is detected. Due to the possibility of excessive leakage current causing false ON conditions, two-wire sensors are not to be used. Only three- or four-wire sensors that have discrete PNP, NPN, or hard-contact outputs separate from the input power can be used.



# DUO-TOUCH® SG – Models AT-GM-11KM and AT-HM-11KM Two-Hand Control Modules

## Muting Functions and Safety Stop Interface

### Mute Enable (ME) Input

The Mute Enable input is a non-safety-rated input. When the input is closed, a mute cycle is allowed to begin; opening this input while the Module is muted will have no effect. **If the application does not require the Mute Enable function, then the X1/X2 input must be jumpered.**

Typical uses for Mute Enable include:

- To allow the machine control logic to create a “window” for muting to begin,
- To inhibit muting from occurring, or
- To reduce the chance of unauthorized or unintended defeat of the safety system.

### Mute Lamp (ML) Output and Configuration

Most applications require that a lamp (or other means) be used to indicate when the safeguard is muted; the AT-..M-11KM provides for this at terminals Z3 and Z4 (see WARNING at right). This indication is selectable between a monitored or a non-monitored output signal (NPN sinking). The monitored output will prevent the initiation of a mute if an indicator failure is detected (current draw falls below 10 mA or goes above 360 mA). If the muting function is to be used in a country governed by EN regulation (requiring the CE mark), Lamp Monitoring must be selected and the lamp used must meet applicable requirements (see Figure 5).

In addition to fulfilling the above requirement, the Mute Lamp output also can be used to prompt the operator when the hand controls may be released. This reduces the chance of premature release of the two-hand control actuators.

### Backdoor Timer

The Backdoor Timer allows the user to select a maximum period of time when muting is allowed to occur (see Figure 5). The Backdoor Timer helps to hinder the intentional defeat of the muting devices and it is also useful in detecting common mode failures that could affect the mute devices.

The timer begins when the second muting device makes the simultaneity requirement (actuated within 3 seconds of the first muting device being actuated), and will allow a mute to continue for the predetermined time. After the timer expires, the mute cycle will end – no matter what the signal from the mute devices indicates – and the safety outputs will open (even if the two-hand control switches are actuated).

### Safety Stop Interface (SSI)

The SSI provides for easy integration of safeguards, E-stop buttons, process control, etc. This input is always active: opening either channel will cause the AT-..M-11KM to issue a stop command. The channels operate concurrently (both must open and re-close, but not necessarily within a certain time frame). **If the SSI is not to be used, terminal X3 must be jumpered to X4, and terminal X5 must be jumpered to X6.**

If the SSI is to be used, the connected device(s) must have electrically isolated, redundant hard contacts (voltage-free). See Figure 8d for hookup information and page 15 for contact specifications.

A variety of safety systems can be interfaced with the SSI. Each safety application has unique application requirements, and the user is responsible for ensuring proper installation, use, and compliance with all relevant standards and regulations. If there are any questions, contact the Banner Factory Applications Group at the phone number on the back page to discuss your intended use.



**WARNING ... Mute Status Must Be Readily Observable**

Indication that the safety device is muted must be provided and must be readily observable. Failure of this indication should be detectable and prevent the next mute, or the operation of the indicator should be verified at suitable intervals. **Lamp monitoring must be selected if the system is to be used in a country governed by EN regulation (i.e., requiring CE mark).**

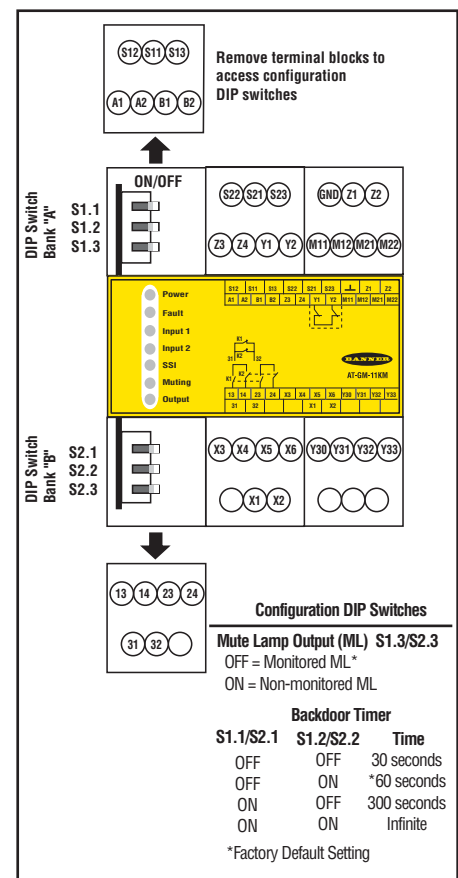

Figure 5. Backdoor Timer setup

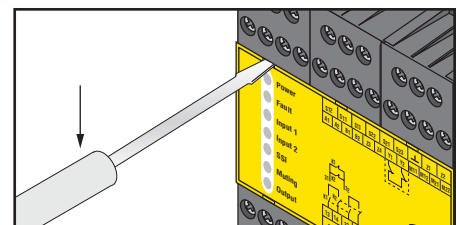

Figure 6. To remove a terminal block, insert a small screwdriver into the slot as shown, and pry to loosen.

# DUO-TOUCH® SG – Models AT-GM-11KM and AT-HM-11KM Two-Hand Control Modules



## CAUTION ... Install Hand Controls to Prevent Accidental Actuation

Total protection for the two-hand control system from “defeat” is not possible. However, regulations require the user to arrange and protect hand controls to minimize possibility of defeat or accidental actuation.

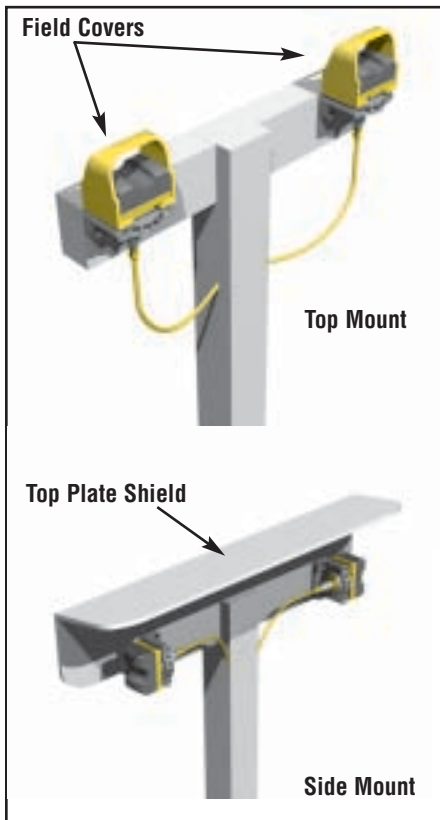

**Figure 7.** Install activation devices so they are protected to prevent defeat or inadvertent actuation (Banner STB Touch Buttons shown)

## Mechanical Installation

### Installation of the DUO-TOUCH SG Safety Module

The DUO-TOUCH Safety Module must be installed inside a NEMA 3 (IEC IP54) rated, or better, enclosure. It is not designed for exposed wiring. Dimensions of the Safety Module are shown in Figure 9. The device mounts directly onto a standard 35 mm DIN rail.

### Heat Dissipation Considerations

For reliable operation, the user must ensure that the operating specifications are not exceeded. The enclosure must provide adequate heat dissipation, so that the air closely surrounding the Module does not exceed the maximum operating temperature stated in the Specifications (page 15). Methods to reduce heat build-up include venting, forced airflow (e.g., exhaust fans), adequate enclosure exterior surface area, and spacing between modules and other sources of heat.

### Installation of Hand Controls

Each actuating device requires a normally open and a normally closed (e.g., Form C or SPDT) hard contacts, each capable of reliably conducting 20mA at 12V dc. For complementary PNP operation, model STBVP.. touch buttons must be used to ensure proper functionality.

Standards require that the actuating devices be mounted to protect them from accidental or unintentional operation. Use shields, covers, rings, collars, dividers, or similar protection to prevent accidental switch actuation and to discourage use of forearms or elbows. European standard ISO13851 includes a detailed discussion of approaches to protection of hand controls.

The hand controls must be arranged far enough apart so that the operator cannot operate both hand controls by the use of one arm (typically, not less than 550 mm/21.7" in a straight line, per ISO13851).

Figure 7 shows two examples for mounting Banner's STB Touch Buttons. When mounted on top of the control bar, the protective field covers should be in place, as shown. For added protection, mount the devices sideways under and behind a protective hood, rather than on top of the bar, leaving the field covers off. This side mount reduces the possibility of the operator easily positioning and leaving an object in the path of the beam, intentionally bypassing the safeguard.

### Requirements for Multiple-Operator Control

Standards have specified several conditions for situations where multiple operators work together to control one machine:

- Each operator must actuate his/her own pair of actuating devices, with all pairs of actuators active at one time, in order to initiate a machine cycle; the machine may not be allowed to operate until this condition is true.
- The actuators all must be released between cycles.
- The actuation and de-actuation of all workstations requiring two-hand control must be supervisable and must provide indication.
- The clutch/brake control system must be designed so that the clutch cannot be actuated if all the operating workstations are bypassed.

It is the responsibility of the user to determine if this two-hand control system can be interfaced to the machine in a manner to satisfy all existing requirements for multiple-operator control.

# DUO-TOUCH® SG – Models AT-GM-11KM and AT-HM-11KM Two-Hand Control Modules

## Separation Distance

Both hand controls must be located far enough away from the nearest hazard point that the operator cannot reach the hazard with a hand or other body part before the hazardous motion ceases. This is the “separation distance,” and may be calculated as follows:

### For Part-Revolution Clutch Machinery

Where the machine and its controls allow the machine to stop motion during the hazardous portion of the machine cycle, use the following formula:

$$D_s = K \times (T_s + T_r + T_h)$$

### For Full-Revolution Clutch Machinery

Where the machine and its controls are designed to complete a full machine cycle, once activated, use the following formula:

$$D_s = K \times (T_m + T_r + T_h)$$

For both formulas:

$D_s$  = the separation distance in inches,

$K$  = 63" per second (the hand speed constant currently accepted by OSHA; see NOTE 1)

$T_s$  = the stop time (in seconds) of the machine, measured from the application of the “stop” signal to the final ceasing of all motion, including stop times of all relevant control elements, and measured at maximum machine velocity (see NOTE 2)

$T_r$  = 0.035 seconds (the response time of the Safety Module as measured from the time either hand disengages a hand control)

$T_h$  = the response time of the slowest hand control (from the time when a hand disengages that control until the switch opens; see NOTE 3)

$T_m$  = the maximum time (in seconds) the machine takes to cease all motion after it has been tripped. For full-revolution clutch presses with only one engaging point,  $T_m$  is equal to the time necessary for one and one-half revolutions of the crankshaft. For full-revolution clutch presses with more than one engaging point,  $T_m$  is calculated as follows:

$$T_m = (1/2 + 1/N) \times T_{cy}$$

where:

$N$  = number of clutch engaging points per revolution

$T_{cy}$  = time (in seconds) necessary to complete one revolution of the crankshaft

## Electrical Installation

Because the DUO-TOUCH SG Safety Module interfaces to many types of machine controls, it is not possible to give exact wiring instructions here. The following guidelines are general in nature.

### Connection of Input Switches

The actuation devices are connected to the DUO-TOUCH SG module as shown in Figures 8a, b, and c. SW1 and SW2 must both have normally open and normally closed output contacts, or two current-sourcing complementary outputs each, all capable of reliably switching up to 20 mA, at 12V dc. If hand controls have metal housings, the housings must be connected to protective earth ground.

If STB Touch Buttons are used, connect the brown and blue wires to terminals Z1 and Z2. If electronic actuation devices other than STB Touch Buttons are used, they must share the same voltage supply with the Safety Module (see Electronic Hand Control WARNING on page 9).



### WARNING ... Location of Touch Button Controls

Hand controls must be mounted at a safe distance from moving machine parts, as determined by the appropriate standard. It must not be possible for the operator or other non-qualified persons to relocate them. Failure to establish and maintain the required safety distance could result in serious injury or death.

### Example Separation Distance ( $D_s$ ) Calculation

The following example illustrates the use of the formula to calculate separation distance for a part-revolution clutch machine. This example uses 0.50 seconds as a typical value for  $T_s$  and 0.020 seconds for  $T_h$ :

$$\begin{aligned} K &= 63" \text{ per second,} \\ T_s &= 0.50 \text{ seconds (measured by a} \\ &\quad \text{stop-time measuring device)} \\ T_r &= 0.035 \text{ seconds} \\ T_h &= 0.035 \text{ seconds} \\ D_s &= K \times (T_s + T_r + T_h) \\ &= 63" (0.50 + 0.035 + 0.035) \\ &= 36" \end{aligned}$$

In this example, both hand controls must be located no closer than 36" from the nearest hazard point.

### NOTES:

- 1) The OSHA-recommended hand speed constant  $K$  has been determined by various studies, and although these studies indicate speeds of 63"/sec to over 100"/sec, they are not conclusive determinations. The employer should consider all factors, including the physical ability of the operator, when determining the value of  $K$  to be used.
- 2)  $T_s$  is usually measured by a stop-time measuring device. If the specified machine stop time is used, add at least 20% as a safety factor to account for brake system deterioration. If the stop-time of the two redundant machine control elements is unequal, the slower of the two times must be used for calculating the separation distance.
- 3)  $T_h$  is usually insignificant for purely mechanical switches. However,  $T_h$  should be considered for separation distance calculation when using electronic or electromechanical (i.e. powered) hand controls. In this example, STB response time = 0.035 seconds.



# DUO-TOUCH® SG – Models AT-GM-11KM and AT-HM-11KM Two-Hand Control Modules



## CAUTION ... Disconnect Power Before Wiring

Always disconnect all power from the DUO-TOUCH SG Safety Module and the machine being controlled before making any wire connections.

Electrical installation of hand controls, the DUO-TOUCH SG Safety Module, and the interconnection to the machine control must be made by qualified personnel and must comply with NEC (National Electrical Code), ANSI/NFPA79 or IEC60204-1, and all applicable local standards.



## WARNING ... Use of Electronic Hand Controls

Electronic (powered) hand controls include optical touch buttons, capacitive touch buttons and similar devices. **When electronic hand controls are used as input switches for a DUO-TOUCH SG Safety Module, the hand controls and the Safety Module must be powered from the same voltage source. Failure to do so creates a potentially dangerous condition, which could result in serious injury or death.**

If power is applied to the Safety Module before power is applied to the electronic hand controls, an output from the DUO-TOUCH SG Safety Module could result and may trigger machine motion. Also, electronic hand controls cannot guarantee the state of their outputs at the time power is applied to them.

## Connection of Power to the DUO-TOUCH SG Safety Module

The Safety Module requires a 24V dc, 115V ac or 230V ac supply voltage (see Specifications on page 15). Use extreme caution whenever installing ac power. Use a minimum of 16 to 18 AWG wire for power and output connections. A hand-operated supply disconnect (e.g. a circuit breaker) must be provided (per NFPA79 and IEC/EN60204).

## Connection to the Machine to be Controlled

Figure 6d shows a generic connection of the Safety Module's two redundant output contacts to machine primary control elements MPCE1 and MPCE2. An MPCE is defined as an electrically-powered element, external to the safety module, which directly controls the machine's normal operating motion so that it is the last (in time) to operate when motion is either initiated or arrested. Some older machines offer only one MPCE; for such machines, it may be necessary to add a second MPCE to establish the appropriate level of safety integrity (e.g., control reliability).

The connection of the safety outputs must be in such a manner that the stop command issued by the AT-GM-11KM can not be overridden by a device or circuit that is not at the same level of safety integrity. This means that the safety outputs are interfaced on the output of the machine logic (e.g., PLC or PC). Then, normally, a feedback signal identifies to the machine logic the status of the safety module and, if possible, the status of the MPCEs. If interposing relays are used, they must be of mechanically linked (forced-guided) design and monitored by the MPCE Monitoring Circuit (Y1/Y2).

As a summary, Control Reliability (OSHA 29CFR1910.217, ANSI B11, and ANSI/RIA R15.06) and Category 3 and 4 (ISO13849-1) requirements demand that a single failure does not lead to the loss of the safety function, or does not prevent a normal or immediate stop from occurring. The failure or the fault must be detected at or before the next demand of safety (e.g., at the beginning or end of a cycle, or when a safeguard is actuated). The safety-related function of the machine control then must issue an immediate stop command or prevent the next machine cycle or hazardous situation until the failure or fault is corrected. **The user must refer to the relevant standard(s) for complete information.**

As shown in Figure 8d, a normally-closed, mechanically linked monitor contact from each of the two MPCEs must be connected in series across terminals Y1 and Y2. This allows the Safety Module to monitor the state of the MPCEs, and to prevent a successive machine cycle, if an MPCE fault is detected. Monitoring MPCE contacts is one method of maintaining control reliability. When MPCE monitor contacts are not available, a jumper wire must be installed across terminals Y1 and Y2.

When a jumper wire is used (dotted line between Y1 and Y2 in Figure 8d), it is the user's responsibility to provide an appropriate level of safety for the means of machine interfacing to ensure that any single MPCE component failure will not result in the loss of safety.

When switching inductive ac loads, it is good practice to protect the Safety Module outputs by installing appropriately-sized arc suppressors. However, if arc suppressors are used, they must be installed across the load being switched (e. g., across the coils of external safety relays), and never across the Safety Module's output contacts (see WARNING on page 10).

# DUO-TOUCH® SG – Models AT-GM-11KM and AT-HM-11KM Two-Hand Control Modules

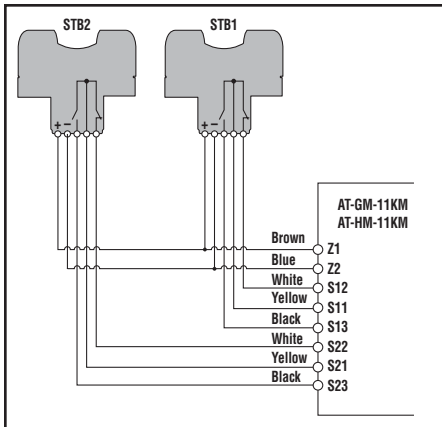

Figure 8a. Hookup to two STB touch buttons with contact outputs

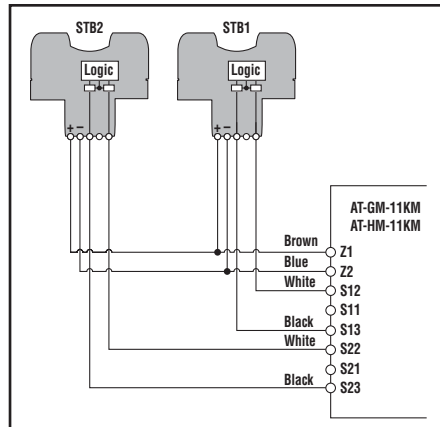

Figure 8b. Hookup to two STB touch buttons with PNP (sourcing) outputs

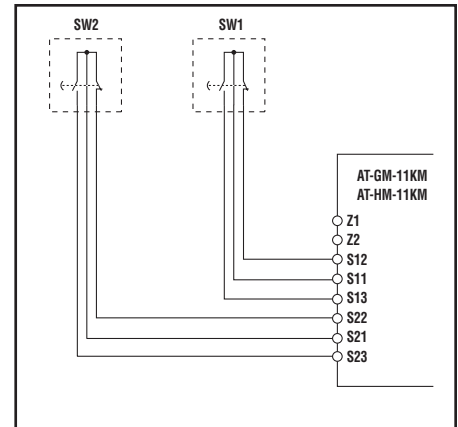

Figure 8c. Hookup to two mechanical push buttons with contact outputs

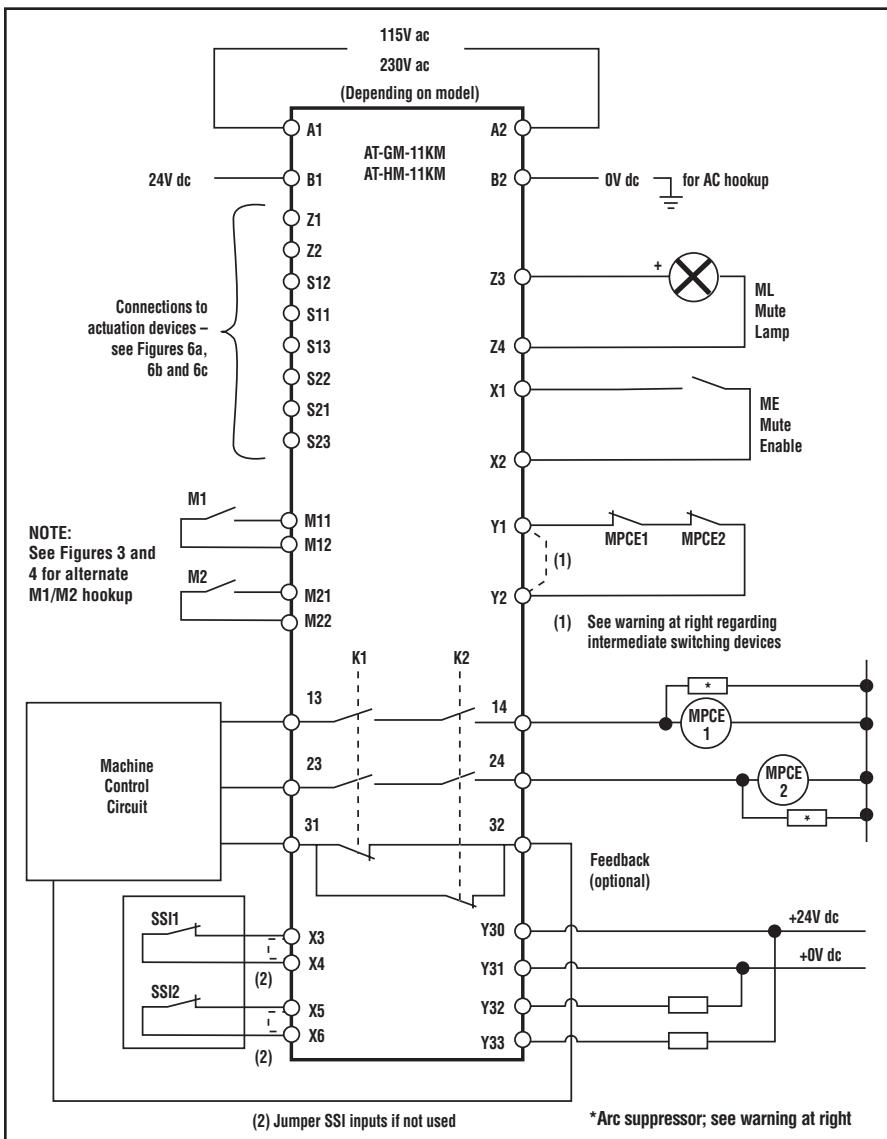

Figure 8d. Machine control circuit connections



## WARNING ... Use of Arc Suppressors

If arc suppressors are used, they **MUST** be installed as shown across the coils of the Machine Primary Control Elements (MPCEs). **NEVER install suppressors directly across the output contacts of the DUO-TOUCH SG Safety Module.** It is possible for suppressors to fail as a short circuit. **If installed directly across the output contacts of the DUO-TOUCH SG Safety Module, a short-circuited suppressor will create an unsafe condition which could result in serious injury or death.**



## WARNING ... Interfacing Safety Outputs

**Never wire or interface an intermediate device (e.g., PLC, PES, PC) that can fail in such a manner that there is the loss of the safety stop command to the MPCEs.** To do so could result in serious bodily injury.

# DUO-TOUCH® SG – Models AT-GM-11KM and AT-HM-11KM Two-Hand Control Modules



## CAUTION ... Disconnect Power Before Checkout

Before performing the initial checkout procedure, make certain all power is disconnected from the machine to be controlled. Temporarily disconnect the wires connected to the outputs of the DUO-TOUCH SG Safety Module at terminals 13/14, 23/24, 31/32, Y32, and Y33.



## WARNING ... Do Not Use System Until Checkouts Are Verified

If all of the described checks cannot be verified, the two-hand-control system must not be used until the problem has been corrected. Injury or death to personnel may result from attempts to use the machine under such conditions.

## Initial Checkout Procedure

To perform the initial checkout, it is necessary to view the red Fault LED and the six green Status indicators. Proceed with caution around open wiring.

If the SSI inputs are to be used, verify the checkout procedures for the external safety systems or other devices connected to the SSI inputs as described by the appropriate manuals. Do not proceed until all checkout procedures are completed successfully and all problems have been corrected.

- 1) Verify that the two actuating devices are properly connected.
- 2) Apply power to the Safety Module and to the actuating devices, if applicable.
- 3) Verify that the Power indicator is ON. The SSI indicator may be ON if the Safety Stop Interface is jumpered (i.e., not used) or if the connected device is in a closed/GO condition. If any other Safety Module indicators are ON, disconnect the power to the Safety Module and check all wiring. **Do not continue this checkout procedure until the cause of the problem is corrected.**
- 4) With the SSI input closed (i.e., SSI LED is ON), activate both hand controls simultaneously (within 0.5 seconds), and hold them engaged. The Output indicators should come ON. Release both hand controls simultaneously. The Output indicators should go OFF.
- 5) Again, activate the two hand controls simultaneously, and hold them engaged. The Output indicators should come ON. Release one hand control while holding the other engaged. One of the Input indicators should remain ON. Re-activate the hand control that was just released. The Input indicator that was OFF should remain OFF. Release both hand controls. Input 1 and Input 2 indicators should then be OFF.
- 6) Activate only one hand control and hold it engaged. Input 1 (or Input 2) indicator should come ON. After more than 1/2 second, activate the second hand control. Input 1 (Input 2) indicator should remain ON, while Input 2 (Input 1) indicator remains OFF.
- 7) Release both hand controls, and open the SSI inputs (if used). Verify that the SSI LED turns OFF. Activate both hand controls simultaneously (within 0.5 seconds), and hold them engaged. Input 1 and Input 2 indicators should come ON, but the Output LED must remain OFF.
- 8) Remove power from the Safety Module and disconnect the monitor contact feedback loop at terminals Y1 and/or Y2. Re-apply power to the Safety Module. Close the SSI inputs, and activate both hand controls simultaneously. Input 1 and Input 2 indicator LEDs should remain OFF.

If the DUO-TOUCH SG Safety Module passes all of these tests, reconnect power to the machine and the output wires at terminals 13/14, 23/24, 31/32, Y31, and Y32. Also reconnect the monitor contact feedback loop at terminals Y1 and Y2. **Do not attempt to use the DUO-TOUCH SG Two-Hand Control Safety Module until all of the previous tests are passed.**

- 9) At this time, perform the Daily Checkout to verify muting function and proper operation.

# DUO-TOUCH® SG – Models AT-GM-11KM and AT-HM-11KM Two-Hand Control Modules

## Periodic Checkout and Maintenance

### Daily Checkout:

To be Performed at every Power-up, Shift Change, and Machine Setup Change

Daily checkout and checkouts after tooling and machine setup changes must be performed by a Designated Person, appointed and identified in writing by the employer.

- 1) Verify that all point-of-operation guards are in place and operating properly.
- 2) Verify that the two actuating devices must be simultaneously engaged to actuate the machine.
- 3) **For single-cycle machines:** Verify that maintained engagement of the two actuating devices results in only one machine cycle.
- 4) **For part-revolution clutch machinery:** Verify that release of either actuating device results in the immediate arrest of the machine motion.
- 5) Verify that the Mute indicator comes ON during the non-hazardous portion of the machine cycle and that the muting function occurs only when exposure to the safeguarded hazard is not possible.
- 6) Verify that release of the hand controls is possible during the mute cycle and that the machine cycle is not stopped.
- 7) Verify that the machine cycle stops any time the mute cycle ends or when the SSI input opens.
- 8) Verify that the distance from each actuating device to the closest hazard point is not less than the calculated safety distance (see page 8).

### Semi-Annual Checkout:

To be Performed at Six-Month Intervals

This semi-annual checkout must be performed by a Qualified Person.\* A copy of the test results should be kept on or near the machine.

- 1) Perform the daily checkout procedure as explained above.
- 2) Perform the initial checkout procedure (see page 11).
- 3) Calculate the separation distance (see page 8), and verify that the actuating devices are far enough away from the nearest hazard point. Relocate the actuating devices, if necessary.
- 4) Verify that the actuating devices are positioned to require the use of both hands for operation, and are protected from false or inadvertent operation.
- 5) Inspect the machine controls and the connections to the DUO-TOUCH SG Safety Module to ensure that wiring is correct, as described on pages 8 and 9, and that no modifications have been made which could adversely affect the System.

\***Qualified Person:** A person who, by possession of a recognized degree or certificate of professional training, or who, by extensive knowledge, training, and experience, has successfully demonstrated the ability to solve problems relating to the installation, maintenance and use of the DUO-TOUCH SG Two-Hand Control Safety System.



**WARNING ... Do Not Use System Until Checkouts Are Verified**

**If all of the described checks cannot be verified, the two-hand-control system must not be used until the problem has been corrected. Injury or death to personnel may result from attempts to use the machine under such conditions.**

# DUO-TOUCH® SG – Models AT-GM-11KM and AT-HM-11KM Two-Hand Control Modules



## CAUTION ... Abuse of Module After Failure

If an internal fault has occurred and the Module will not reset, **do not tap, strike, or otherwise attempt to correct the fault by a physical impact to the housing.** An internal relay may have failed in such a manner that its replacement is required.

**If the Module is not immediately replaced or repaired, multiple simultaneous failures may accumulate such that the safety function can not be guaranteed.**

## Repairs

**NOTE: Do not attempt any repairs to the DUO-TOUCH SG Two-Hand Control Module. It contains no field-replaceable components. Return it to the factory for warranty repair or replacement.**

If it ever becomes necessary to return a DUO-TOUCH SG Safety Module to the factory, please do the following:

- 1) Contact the Banner Factory Application Engineering Group at the address or at the numbers listed at the bottom of the back page. They will attempt to troubleshoot the system from your description of the problem. If they conclude that a component is defective, they will issue an RMA (Return Merchandise Authorization) number for your paperwork, and give you the proper shipping address.
- 2) Pack the component carefully. Damage which occurs in return shipping is not covered by warranty.

## LED Indicators

Two-Hand Control Module AT-.M-11KM provides seven indicator LEDs

<b>Power</b> (Green)	<b>ON</b> – Power is connected to terminals A1-A2. <b>OFF</b> – No power or low power to terminals A1-A2, or internal power supply failure. <b>Flashing</b> (only; no other LEDs are ON) – DIP Switch Fault. See page 6.
<b>Fault</b> (Red)	<b>ON</b> – External fault or configuration fault. The corresponding function LED (see below) will flash to indicate the area where the fault has been detected. See below or the Troubleshooting Table for probable cause. <b>OFF</b> – Normal operation. <b>Flashing</b> (only; no other LEDs are ON other than “power”) – Internal Fault. See above for repair.
<b>Input #1</b> (Green)	<b>ON</b> – touch button (Input #1) is activated. <b>OFF</b> – touch button is not activated. <b>Flashing</b> – See Troubleshooting Table for probable cause.
<b>Input #2</b> (Green)	<b>ON</b> – touch button (Input #2) is activated. <b>OFF</b> – touch button is not activated. <b>Flashing</b> – See Troubleshooting Table for probable cause.
<b>Safety Stop Input</b> (Green)	<b>ON</b> – SSI inputs are closed (X3/X4 and X5/X6). <b>OFF</b> – SSI inputs are open. <b>Flashing</b> – See Troubleshooting Table for probable cause.
<b>Mute</b> (Green)	<b>ON</b> – M1/M2 are closed and mute cycle is activated. <b>OFF</b> – M1/M2 are not closed (mute cycle not activated). <b>Flashing</b> – Mute cycle is prevented because of M1/M2 simultaneity error, Mute Lamp error, Mute Enable not closed before M1/M2 active, power-up with M1/M2 closed, Backdoor timer expired with M1/M2 closed.
<b>Output</b> (Green)	<b>ON</b> – Both internal relays K1 and K2 are energized. (Safety outputs 13-14 and 23-24 are closed. Auxiliary output 31-32 is open.) <b>OFF</b> – Both internal relays K1 and K2 are de-energized. (Safety outputs 13-14 and 23-24 are open. Auxiliary output 31-32 is closed.) <b>Flashing</b> – Y1/Y2 Feedback Input open.



# DUO-TOUCH® SG – Models AT-GM-11KM and AT-HM-11KM Two-Hand Control Modules

## Troubleshooting

Condition: Outputs Will Not Energize		Condition: Module Will Not Mute	
Indicator Status	Possible Reason/Solution	Indicator Status	Possible Reason/Solution
Power ON Fault ON In #1 ON or OFF In #2 ON or OFF SSI ON MUTE OFF OUT OFF	Two-Hand Control Input Simultaneity Error - Simultaneity failure (> 500 ms) with status of input.	Power ON Fault ON In #1 ON In #2 ON SSI ON MUTE Flashing OUT ON	M1/M2 Input Simultaneity Error - Simultaneity failure (> 3.0 s)
Power ON Fault ON In #1 ON In #2 ON SSI ON MUTE OFF OUT Flashing	External Device Monitoring (EDM) error - Feedback open (Y1/Y2)	Power ON Fault OFF In #1 ON or OFF In #2 ON or OFF SSI ON MUTE Flashing OUT On or OFF	Muting Error – Muting Disallowed - Mute Enable (ME) open - Mute Lamp (ML) failure
Power ON Fault ON In #1 Flashing or OFF In #2 Flashing or OFF SSI ON MUTE OFF OUT OFF	Two-Hand Control Input Error - Input invalid (NO/NC within an input did not switch within 100 ms) - Both channels within an input are closed (S12/S11/S13 or S22/S21/S23) - Both channels within an input are open (S12/S11/S13 or S22/S21/S23)	<b>Condition: Mute Drops Out and Will Not Mute Again</b>	
Power ON Fault Flashing In #1 Flashing In #2 Flashing SSI OFF MUTE OFF OUT OFF	Two-Hand Control Input Short Circuit - Input #1 is short circuited to Input #2 (S12/S11/S13 to S22/S21/S23)	Indicator Status	Possible Reason/Solution
Power ON Fault Flashing In #1 ON or OFF In #2 ON or OFF SSI Flashing MUTE OFF OUT OFF	Safety Stop Interface Error - Invalid Input – SSI channels did not operate concurrently, both must open and then both must re-close (X3/X4 and X5/X6)	Power ON Fault OFF In #1 Flashing In #2 Flashing SSI ON MUTE Flashing OUT ON	Backdoor Timer Expired - M1/M2 and Two-Hand Control Inputs closed after Backdoor timer expired.
Power ON Fault Flashing In #1 Flashing or OFF In #2 Flashing or OFF SSI OFF MUTE Flashing or OFF OUT OFF	Power-Up Error NOTE: This error is a non-recoverable lockout; the power must be removed, the Inputs must be de-activated (cleared or opened) and then power reapplied. - Two-Hand Control Inputs are active, tied-down, or miswired at power-up (corresponds to flashing In#1/In#2 LEDs). - M1/M2 Input(s) closed at power-up (corresponds to flashing MUTE LED)		

NOTE: See LED Indicator Chart (page 13) for further troubleshooting hints.

# DUO-TOUCH® SG – Models AT-GM-11KM and AT-HM-11KM Two-Hand Control Modules

## DUO-TOUCH SG Safety Module Specifications

<b>Supply Voltage and Current</b>	<b>A1-A2:</b> 115V ac (Model AT-GM-11KM) or 230V ac (Model AT-HM-11KM), +/- 15%; 50/60Hz <b>B1-B2:</b> 24V dc, +/- 15%, 10% max. ripple
<b>Power Consumption</b>	Approx. 4 W / 7 VA
<b>Supply Protection Circuitry</b>	Protected against transient voltages and reverse polarity
<b>Output Configuration</b> (including Auxiliary N.C. output 51/52)	<b>Outputs (K1 and K2):</b> two redundant (total of four) safety relay (forced-guided) contacts <b>Contact ratings:</b> <b>Maximum voltage:</b> 250V ac or 250V dc <b>Maximum current:</b> 6A ac or dc (resistive load) <b>Maximum power:</b> 1500 VA, 100 watts <b>Mechanical life:</b> 50,000,000 operations <b>Electrical life:</b> 150,000 cycles (typically @ 1.5 kVA switching power) NOTE: Transient suppression is recommended when switching inductive loads. Install suppressors across load. Never install suppressors across output contacts (see Warning on page 10).
<b>Auxiliary Supply Voltage</b> (for solid-state outputs)	24V dc @ 1A (applied between Y30 & Y31)
<b>Auxiliary Solid-State Output Current</b>	500 mA max., short circuit protected, Y32 is a PNP output, Y33 is an NPN output
<b>Output Response Time</b>	35 milliseconds maximum ON to OFF
<b>Input Requirements</b>	Outputs from actuating devices must each be capable of switching up to 20 mA @ 12V dc.
<b>Simultaneity Monitoring Period</b>	≤ 500 milliseconds
<b>Z1/Z2 Courtesy Voltage</b>	24V dc @ 150 mA (for STB button power, separate from Auxiliary output, unregulated)
<b>External Device Monitoring (EDM)</b>	One pair of terminals (Y1 and Y2) are provided to monitor the state of external devices controlled by the safety outputs. Each device must be capable of switching 15 to 30V dc at 10-50 mA.
<b>Muting Device Inputs (M1, M2)</b>	The muting devices work as a pair (M1 and M2). The simultaneity requirement is that they be “closed” within 3 seconds of each other to initiate a mute condition or allow a mute cycle, assuming all other conditions are met. Each muting device must be capable of switching 15 to 30V dc at 10-50 mA.
<b>Mute Enable Input (ME)</b>	Mute Enable input must be closed in order to start a mute cycle. Opening this input after a mute cycle has begun has no effect. The switching device must be capable of switching 15 to 30V dc at 10-50 mA.
<b>Safety Stop Interface (SSI)</b>	This input consists of two concurrent channels (SSI-A and SSI-B) and is always active. Any time either or both channels open, the Safety Outputs will go OFF. When using the SSI, the external device must be capable of switching 15 to 30V dc at 10-50 mA.
<b>Status Indicators</b>	6 green LED indicators and 1 red LED indicator (see Figure 1 and page 13)
<b>Housing</b>	Polycarbonate. Rated NEMA 1 (IEC IP20)
<b>Mounting</b>	Mounts to standard 35 mm DIN rail track. Safety Module must be installed inside an enclosure rated NEMA 3 (IEC IP54), or better.
<b>Vibration Resistance</b>	10 to 55Hz @ 0.35 mm displacement per IEC 68-2-6
<b>Operating Conditions</b>	<b>Temperature:</b> 0° to +50°C (+32° to 122°F) <b>Maximum Relative Humidity:</b> 90% @ +50°C (non-condensing) <b>Heat Dissipation Considerations:</b> See page 7.
<b>Dimensions</b>	See Figure 9 on the back page.
<b>Safety Category</b>	4 per ISO 13849-1; Type IIIC per ISO 13851 (EN574)
<b>Certifications</b>	Approvals in process. Contact factory for more information.

# DUO-TOUCH® SG – Models AT-GM-11KM and AT-HM-11KM Two-Hand Control Modules

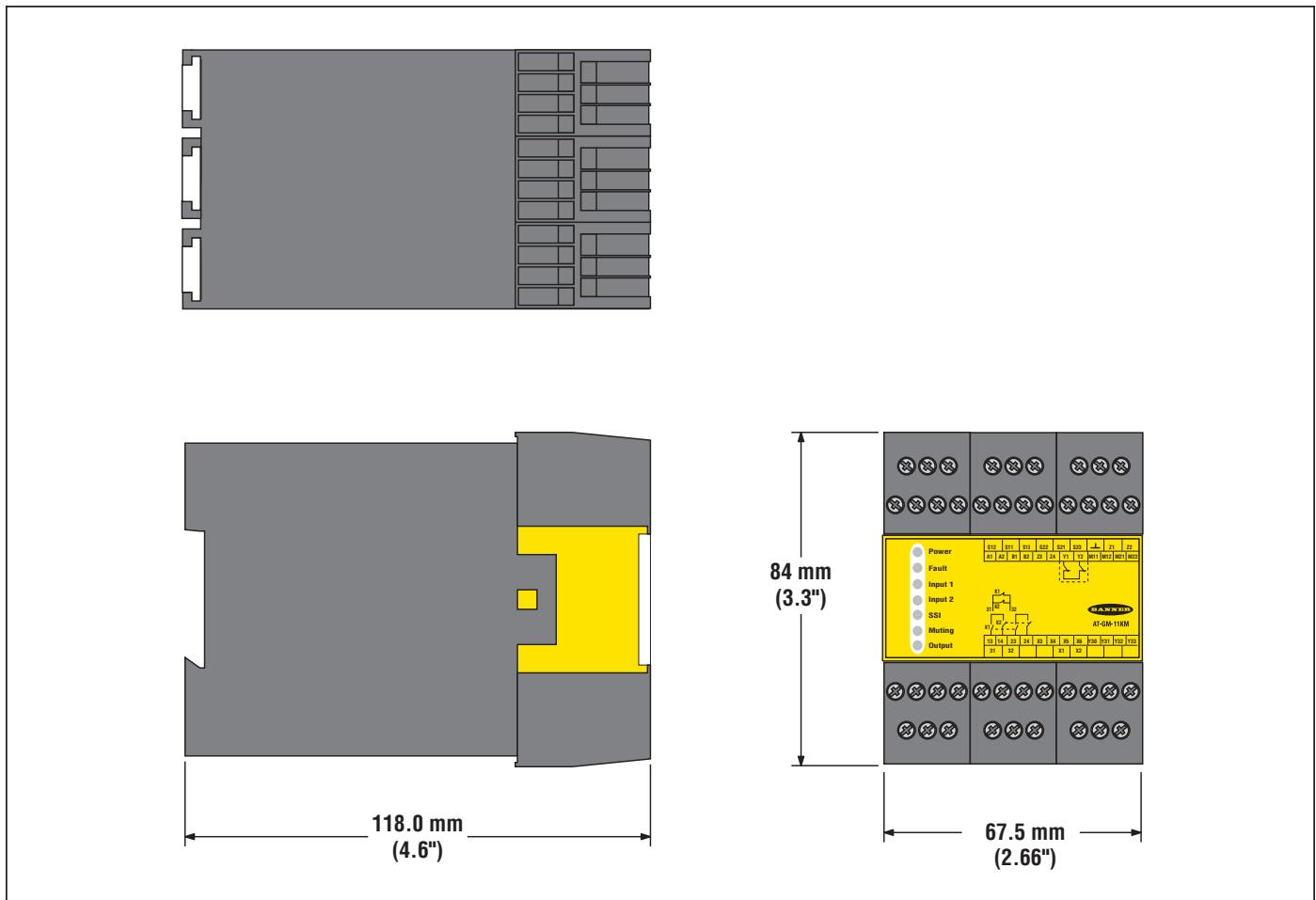

Figure 9. DUO-TOUCH SG Safety Module models AT-..M-11KM dimensions



**WARRANTY:** Banner Engineering Corp. warrants its products to be free from defects for one year. Banner Engineering Corp. will repair or replace, free of charge, any product of its manufacture found to be defective at the time it is returned to the factory during the warranty period. This warranty does not cover damage or liability for the improper application of Banner products. This warranty is in lieu of any other warranty either expressed or implied.