

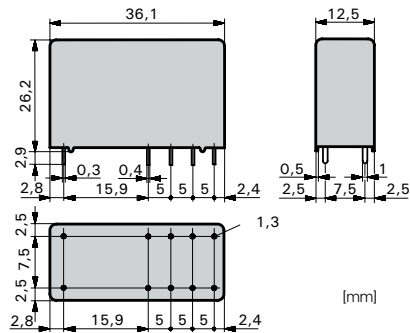

Relay data

- PCB relay with forcibly guided contacts
- Protective separation between coil and contacts (leakage and creeping distances > 14mm); protective separation between left and right contact side (leakage and creeping distances > 5.5mm)
- EN 50205, type A
- Contact mounting: SIM312 3NO/1NC
SIM222 2NO/2NC
- Small external dimensions
- Mean coil power 1W



Contact material	AgSnO ₂ +0,2μm Au
Type of contact	Crest contact
Rated switching capacity	250VAC 8A AC1 2'000VA
Electr. life AC1 (360 cycles/h)	approx. 100'000
Inrush current max.	20A for 20ms
Switching current range*	10mA to 8A
Switching capacity range*	0,06VA(W) to 2'000VA
Contact resistance (as delivered)	≤ 100mΩ

* Guide values

Standard coils for direct current (other voltages on request)

Nominal voltage VDC	Min. pick-up voltage at 20°C	Drop-out voltage at 20 °C	Nominal current in mA	Resistance in Ohm at 20 °C	Tolerance in %
5	3,75	≥ 0,5	181,8	27,5	± 10
6	4,5	≥ 0,6	166,0	36	± 10
12	9,0	≥ 1,2	85,7	140	± 10
24	18,0	≥ 2,4	40,0	600	± 10
48	36,0	≥ 4,8	20,8	2'300	± 10
60	45,0	≥ 6,0	16,6	3'600	± 13
110	82,5	≥ 11,0	9,6	12'000	± 15

Ordering example

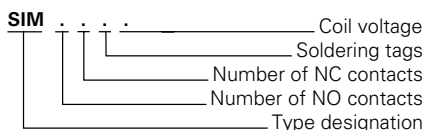

General data

Circuit diagram (view on relay upper side)

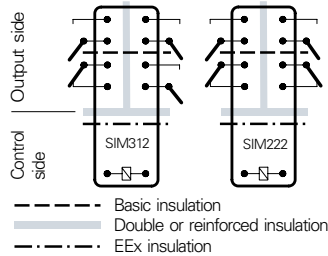

Mechanical life	> 10 x 10 ⁶ operations
Switching frequency, mechanical	15Hz
Response time	typically 8ms
Drop-out time**	typically 4ms
Bounce time of NO contact	typically 6ms
Bounce time of NC contact	typically 12ms
Shock resistance	16ms NO contact > 10g
Vibration resistance	10-200Hz NO contact > 10g
Test voltage coil/contacts	5'000Veff 1min
Test voltage left to right contact sides	4'000Veff 1min
Test voltage contacts as one after the other	2'500Veff 1min
Test voltage contact open	1'500Veff 1min
Insulation resistance	10 ¹¹ Ω
Creeping resistance	CTI 250
Weight	approx. 25g
Mounting position	any
Ambient temperature	-40°C to +70°C
Type of protection	RT II
Solder bath temperature	270 °C/5s
Thermal resistance	50K/W
Temperature limit for coil	120°C
Pollution degree	3
Overvoltage category	III
Resistance to short circuiting	1'000A SCPD 10A gG (pre-fuse)

** without spark suppression

Insulation terms

Coil/contacts: Double or reinforced insulation
EEx insulation > 14mm
Left to right contact side:
Double or reinforced insulation > 5,5mm
Contacts in one row: Basic insulation

Tests, regulations

Approvals	SEV, UL, cUL, TÜV
Insulation class	VDE 0110 / group C 250VAC
Protection class II	VDE 0106
Fire protection requirements	UL 94 / V0

Options, accessories

PCB socket, DIN rail socket see page 24

Diagrammes

Contact lifetime for NO contact

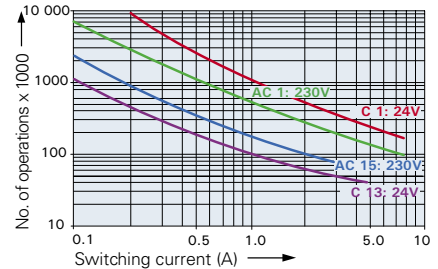

Max. switching characteristics (determined acc. to DIN EN 60947-5-1 table C2):
AC 15: 230V/3A
DC 13: 24V/4A
DC 13: 24V/6A/0,1Hz

Maximal contact load at AC 1 with 230V:
2 contacts each with 8A
3 contacts each with 6A

Load limit curve with direct current

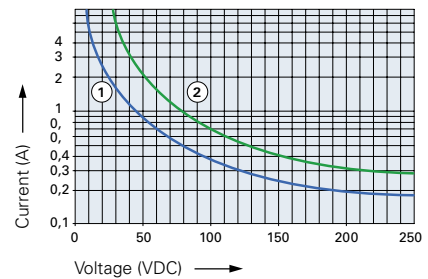

- 1) Inductive load, L/R 40 ms
- 2) Resistive load

Excitation voltage range

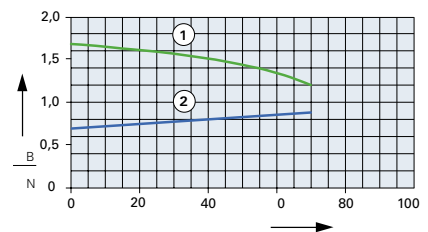

- 1) Max. excitation voltage with contact load ≤ 2A
- 2) Min. excitation voltage (guaranteed values) without previous operation

No heat accumulation due to intrinsic heating of other components.
Continuous duty 100%.