

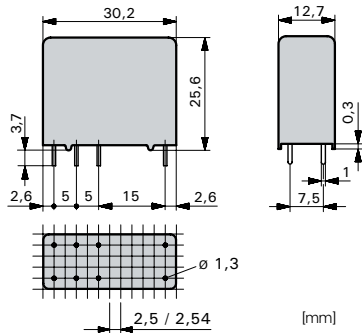

Relay data

- PCB relay with forcibly guided contacts
- Protective separation between coil and contacts (leakage and creeping distances > 14mm); protective separation diagonally between left and right contact side (leakage and creeping distances > 5,5mm)
- EN 50205, type B
- 2 CO contacts
- Mean coil power 1 W



Contact material	AgCuNi
Type of contact	Single contact
Rated switching capacity	250VAC 6A AC1 1'500VA
Electr. life AC1 (360 cycles/h)	approx. 100'000
Inrush current max.	15A for 20ms
Switching current range*	20mA to 6A
Switching current range**	10mA to 6A
Switching capacity range*	0,12VA(W) to 1'500VA
Switching capacity range**	0,06VA(W) to 1'500VA
Contact resistance (as delivered)	≤ 100mΩ

* Guide values
** Values for AgCuNi + 4-6 μm Au

Standard coils for direct current
(other voltages on request)

Nominal voltage VDC	Min. pick-up voltage at 20°C	Drop-out voltage at 20°C	Nominal current in mA	Resistance in Ohm at 20°C	Tolerance in %
5	3,75	≥ 0,5	181,8	27,5	± 10
6	4,5	≥ 0,6	166,6	36	± 10
12	9,0	≥ 1,2	85,7	140	± 10
24	18,0	≥ 2,4	33,3	720	± 10
48	36,0	≥ 4,8	20,8	2'300	± 10
60	45,0	≥ 6,0	13,6	4'400	± 13
110	82,5	≥ 11,0	11,0	10'000	± 15

Ordering example

GR282Z 24VDC S AgCuNi Au ZGR008

Type designation
Coil voltage
Special design / sensitive coil
Contact material
Gold plating 4 - 6μm Au
Wash-resistant, RT III

General data

Circuit diagram (view on relay upper side)

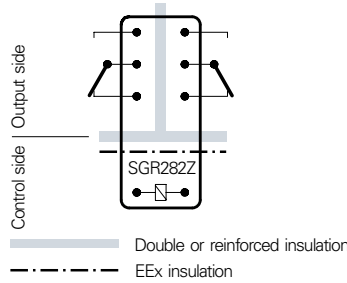

Mechanical life	> 50 x 10 ⁶ operations
Switching frequency, mechanical	20Hz
Response time	typically 12ms
Drop-out time***	typically 5ms
Bounce time of NO contact	typically 4ms
Bounce time of NC contact	typically 8ms
Vibration resistance	10-55Hz, AK 10g, RK 1,5g
Test voltage coil/contacts	5'000Veff 1min
Test voltage contact set/contact set	4'000Veff 1min
Test voltage contact open	1'500Veff 1min
Insulation resistance	10 ¹¹ Ω
Creeping resistance	CTI 550
Weight	approx. 20g
Mounting position	any
Ambient temperature	-40°C to +70°C
Type of protection	RT II / RT III optionally
Solder bath temperature	270°C/5s
Thermal resistance	50K/W
Temperature limit for coil	120°C

*** without spark suppression

Insulation terms

Coil/contacts: Double or reinforced insulation
EEx insulation > 14mm
Left to right contact side:
Double or reinforced insulation > 5,5mm

Tests, regulations

Approvals SEV, UL, cUL, TÜV, PTB
Insulation class VDE 0110 / group C 250VAC
Protection class II VDE 0106
Fire protection requirements UL 94 / V1

Options, accessories

Contact material SGR282Z..VDC AgCuNi
+4 - 6μm Au
PCB socket, DIN rail socket see page 23
Wash-resistant RT III SGR282Z..VDC ZGR008

Diagrammes

Contact lifetime for AgCuNi

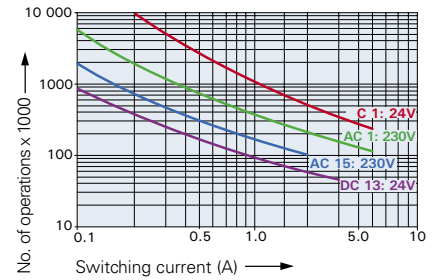

Max. switching characteristics (acc. to DIN EN 60947-5-1 table C2):
AC 15: 230V/3A, DC13: 24V/4A

Maximal contact load at AC 1 with 230V:
2 contacts each with 6A

Gold contacts with 4-6μm layer thickness

When high voltages and currents are switched, the layer of gold is destroyed already after a few switching operations. Once the gold layer is damaged due to the switching of high loads, such a contact must not be used any more for signal and control current circuits. Safe contact making is then only possible at high loads with the formation of sparks.

Load limit curve with direct current

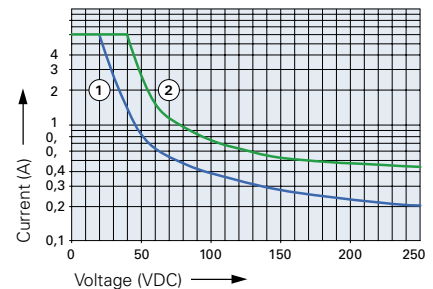

- 1) Inductive load, L/R 40 ms
- 2) Resistive load

Excitation voltage range

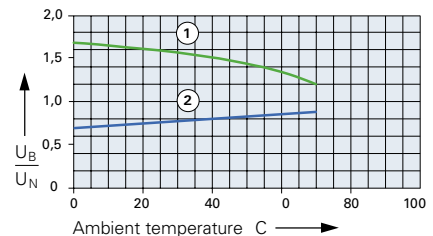

- 1) Max. excitation voltage with contact load ≤ 2A
- 2) Min. excitation voltage (guaranteed values) without previous operation

No heat accumulation due to intrinsic heating of other components.
Continuous duty 100%.



American Electronic Components, Inc.

1101 Lafayette Street, Elkhart, IN 46516, Tel: (574) 295-6330, Fax: (574) 293-8013, sales@aecsensors.com