

1 AND 2-AXIS MAGNETIC SENSORS

Features

- Small 8-Pin SIP or 10-Pin MSOP Packages
- Two AMR Bridges in One Package
- Wide Field Range of ± 6 Gauss
- 1.0 mV/V/gauss Sensitivity
- High Accuracy Compassing (Error $<0.01^\circ$)
- Low Power Operation Down to 1.8V
- Patented On-chip Set/Reset Straps

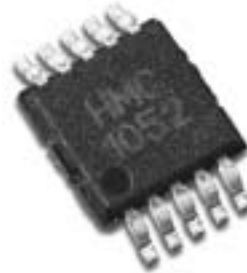

Product Description

The Honeywell HMC1051Z and HMC1052 are high performance magnetoresistive sensor designs on a single chip. The advantages of these patented chips include perfectly orthogonal two-axis sensing (HMC1052), ultra small size and low power capability in miniature surface mount packages.

Each of the magnetoresistive sensors are configured as a 4-element wheatstone bridge to convert magnetic fields to differential output voltages. Capable of sensing fields below 0.1 milligauss, these sensors offer a compact, low cost, high sensitivity and highly reliable solution for low field magnetic sensing.



APPLICATIONS

- **Compassing**
- **Navigation Systems**
- **Attitude Reference**
- **Traffic Detection**
- **Medical Devices**
- **Position Sensing**

HMC1052 Circuit Diagram

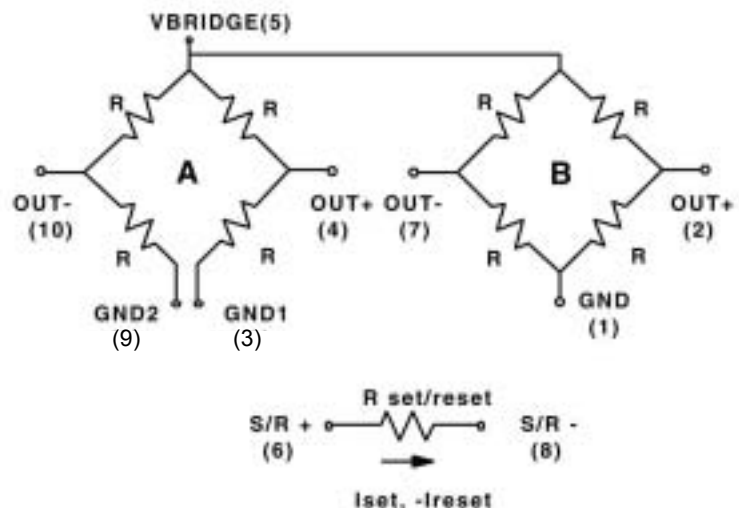

SPECIFICATIONS

Characteristics	Conditions*	Min	Typ	Max	Units
Bridge Elements					
Supply	Vbridge referenced to GND	1.8	3.0	20	Volts
Resistance	Bridge current = 1mA	800	1000	1500	ohms
Field Range	Full scale (FS) – total applied field	-6		+6	gauss
Sensitivity	Set/Reset Current = 0.5A	0.8	1.0	1.2	mV/V/gauss
Bridge Offset	Offset = (OUT+) – (OUT-) Field = 0 gauss after Set pulse	-1.25	±0.5	+1.25	mV/V
Bandwidth	Magnetic signal (lower limit = DC)		5		MHz
Noise Density	@ 1kHz, Vbridge=5V		50		nV/sqrt Hz
Resolution	50Hz Bandwidth, Vbridge=5V		120		μgauss
Disturbing Field	Sensitivity starts to degrade. Use S/R pulse to restore sensitivity.	20			gauss
Max. Exposed Field	No perming effect on zero reading			10000	gauss
Operating Temperature	Ambient	-40		125	°C
Storage Temperature	Ambient, unbiased	-55		150	°C
Sensitivity Tempco	T _A = -40 to 125°C, Vbridge=5V T _A = -40 to 125°C, Ibridge=5mA	-3000	-2700 -600	-2400	ppm/°C
Bridge Offset Tempco	T _A = -40 to 125°C, No Set/Reset T _A = -40 to 125°C, With Set/Reset		±500 ±10		ppm/°C
Bridge Ohmic Tempco	Vbridge=5V, T _A = -40 to 125°C	2100	2500	2900	ppm/°C
Sensitivity Ratio of X,Y Sensors (HMC1052 Only)	T _A = -40 to 125°C	95	100	105	%
X,Y sensor Orthogonality (HMC1052)	Sensitive direction in X and Y sensors			0.01	degree
Linearity Error	Best fit straight line ± 1 gauss ± 3 gauss ± 6 gauss		0.1 0.5 1.8		%FS
Hysteresis Error	3 sweeps across ±3 gauss		0.06		%FS
Repeatability Error	3 sweeps across ±3 gauss		0.1		%FS

* Tested at 25°C except stated otherwise.

SPECIFICATIONS

Characteristics	Conditions*	Min	Typ	Max	Units
Set/Reset Strap					
Resistance	Measured from S/R+ to S/R-	3	4	5	ohms
Current	0.1% duty cycle, or less, 2μsec current pulse	0.4	0.5	4	Amp
Resistance Tempco	T _A = -40 to 125°C	3300	3700	4100	ppm/°C

Offset Straps (available on die)

Resistance	Measured from OFFSET+ to OFFSET-	12	15	18	ohms
Offset Constant	DC Current Field applied in sensitive direction		10		mA/gauss
Resistance Tempco	T _A = -40 to 125°C	3500	3900	4300	ppm/°C

* Tested at 25°C except stated otherwise.

Pin Configurations (Arrow indicates direction of applied field that generates a positive output voltage after a SET pulse.)

HMC1051

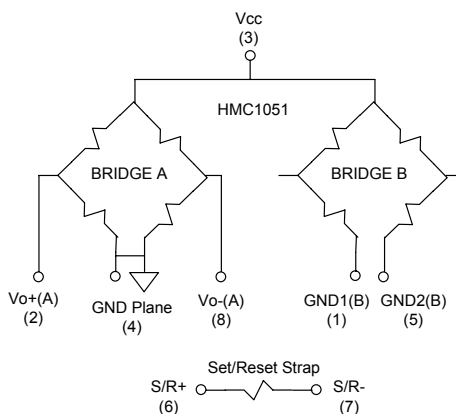

HMC1051Z Pinout

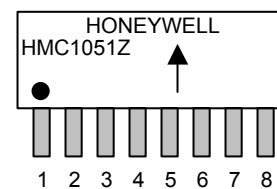

HMC1052

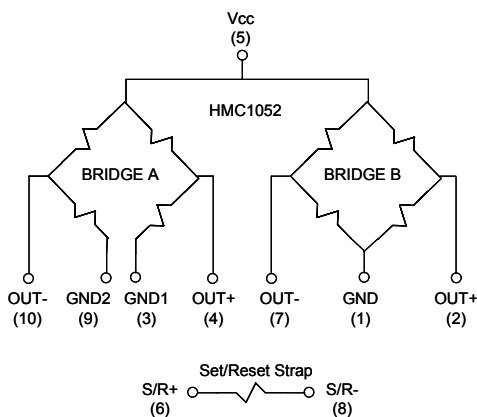

HMC1052 Pinout

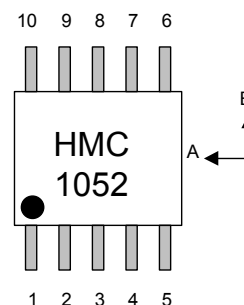

Basic Device Operation

The HMC1051 and HMC1052 are single-axis and two-axis linear magnetic sensors designed as a Wheatstone bridges formed by a magnetoresistive metal film. With the power supply applied to the bridge, the sensors convert any incident magnetic field in the sensitive direction to a balanced voltage output. The magnetoresistive sensors are made of a nickel-iron (Permalloy) thin-film deposited on a silicon wafer in pattern of resistive strips. In the presence of a magnetic field, a change in the bridge resistive elements causes a corresponding change in voltage across the bridge outputs.

In addition to the bridge circuits, the sensors each have two on-chip magnetically coupled straps; the Offset Strap and the Set/Reset Strap. The patented straps eliminate the need for external coils surrounding the bridge elements. The offset strap (available on bare die only) allows for several modes of operation when a direct current is driven through it. These modes are: 1) Subtraction of an unwanted magnetic field, 2) Zero-ing of the bridge offset voltage, 3) Closed loop field cancellation, and 4) Auto-calibration of bridge gain. The set/reset strap can be pulsed with high currents for the following benefits: 1) Enable the sensor to perform high sensitivity measurements, 2) Flip the polarity of the bridge output voltage, and 3) Periodically used to improve linearity, lower cross-axis effects, and temperature effects.

Application Notes

Low Cost 2-Axis Compass

Very high precision measurements can be made using the HMC1051 and HMC1052 sensors when interfaced with low noise amplifiers and 12 to 16-bit Analog-to-Digital (A/D) converters. For lower resolution (1°) or low cost compass applications, 8 or 10-bit A/D converters may be used with general purpose operational amplifiers. Figure 1 shows a typical 2-axis compassing application using readily available off-the-shelf components.

The basic principle of two-axis compassing is to orient the sensor bridge element horizontal to the ground (perpendicular to the gravitational field) and to measure the X and Y analog voltages. With the amplified sensor bridge voltages near-simultaneously converted (measured) to their digital equivalents, the arc-tangent Y/X can be computed to derive the heading information. See the application notes on compassing at Honeywell Magnetic Sensors website (www.magneticsensors.com) for basic principles and detailed application information.

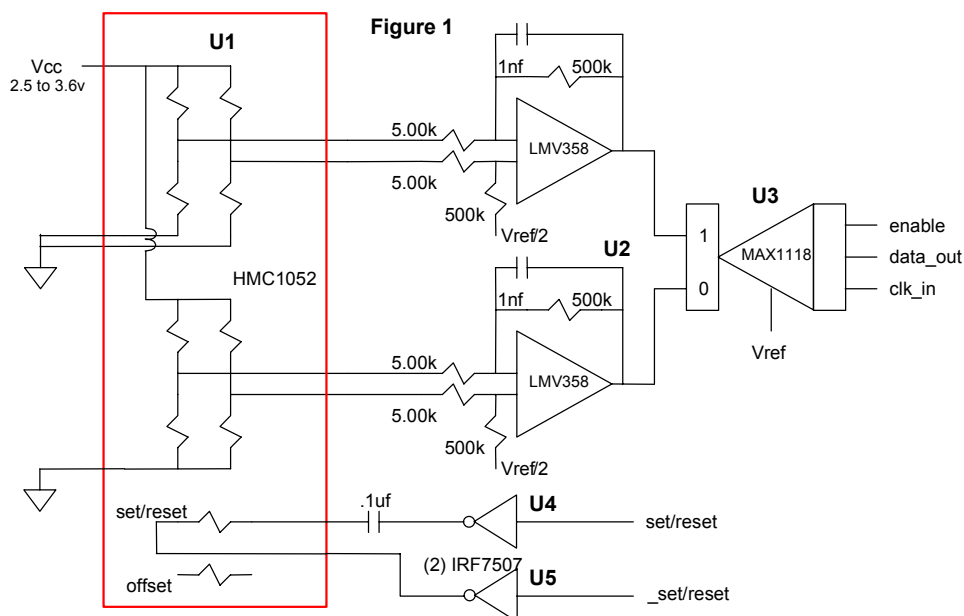

Set/Reset Circuit Notes

The set/reset circuit using the IRF7507 dual complementary MOSFETs is shown in Figure 2 with more detail in its H-bridge driven configuration. This configuration is used primarily in battery operated applications where the 0.5 ampere nominal set/reset pulsed currents are best obtained under low voltage conditions. For operation at normal 3.3 or 5 volt logic levels, a single complementary MOSFET pair can be used in a single ended circuit shown in Figure 3. Other complementary MOSFET pairs can be used with the caution that the chosen devices should have less than 0.5 ohms ON resistance and be able to handle the needed supply voltages and set/reset currents. Note that even a 1Hz rate of set/reset function draws an average current of less than 2 microamperes.

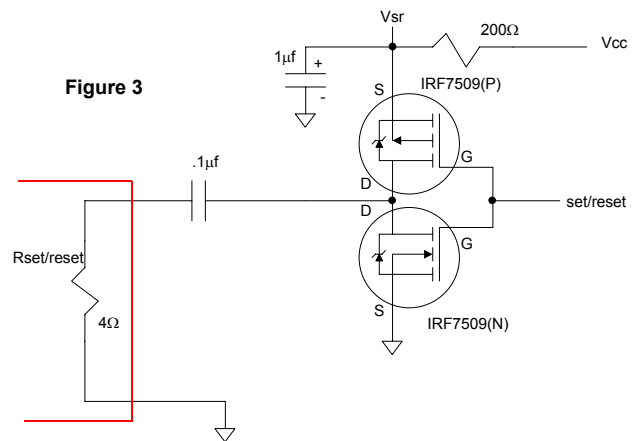
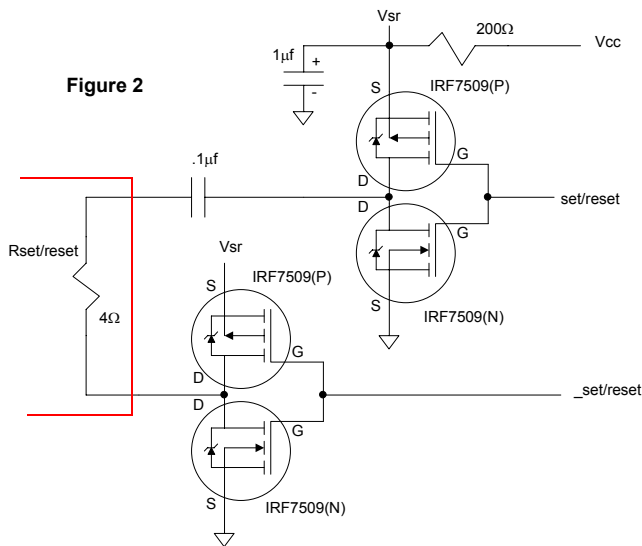

Magnetic Field Detection

For simple magnetic field sensing applications such as Magnetic Anomaly Detectors (MADs) and Magnetometers, a similar circuit to the compass application can be implemented. In the example circuit in Figure 4, a HMC1051Z sensor bridge is used with a low voltage capable dual op-amp to detect sufficient intensity of a magnetic field. Uses of the circuit include ferrous object detection such as vehicle detection, a “sniffer” for moderate currents in nearby conductors, and magnetic proximity switching. By using two circuits with a HMC1052, a more omni-directional sensing pattern can be implemented. There is nothing special in choosing the resistors for the differential op-amp gain stages other than having like values (e.g. the two 5kΩ and the 500kΩ resistors) matched at 1% tolerance or better to reject common-mode interference signals (EMI, RFI). The ratio of the 500kΩ/5kΩ resistors sets the stage gain and can be optimized for a specific purpose. The choice of the 5kΩ value sets impedance loading seen by the sensor bridge network and should be about 4 kilo-ohms or higher for best voltage transfer or matching.

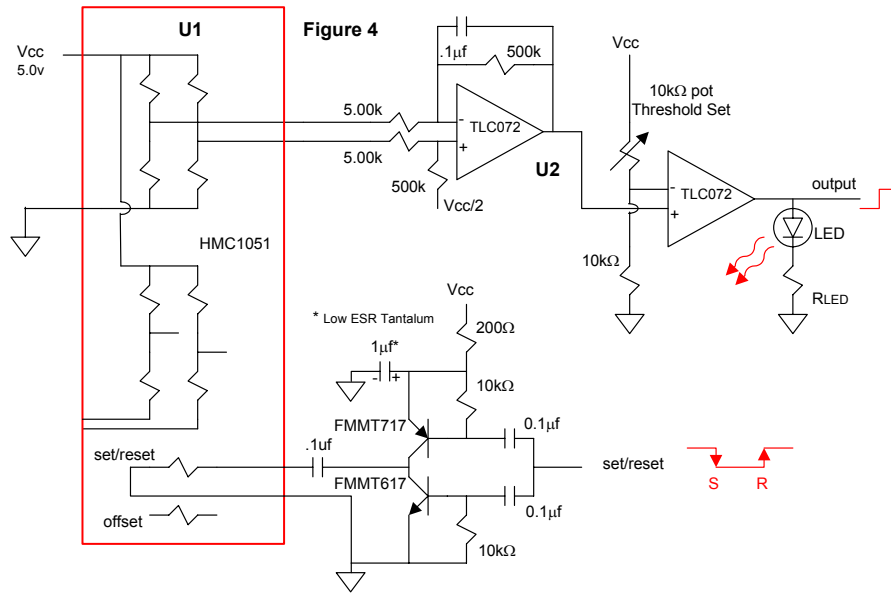

Alternating or Direct Current Sensing

The HMC1051 and HMC1052 sensors can be utilized in a novel way for moderate to high current sensing applications using a nearby external conductor providing the sensed magnetic field to the bridge. Figure 5 shows a HMC1051Z used as a current sensor with thermistor element performing a temperature compensation function for greater accuracy over a wide range of operational temps. Selection of the temperature compensation (tempco) resistors used depends on the thermistor chosen and is dependant on the thermistor's %/°C shift of resistance. For best op-amp compatibility, the thermistor resistance should be above about 1000 ohms. The use of a 9-volt alkaline battery supply permits fairly common operational amplifiers such as the 4558 types to be used. Note that the circuit must be calibrated based on the final displacement of the sensed conductor to the measuring bridge. Typically, an optimally oriented measurement conductor can be placed about one centimeter away from the bridge and have reasonable capability of measuring from tens of milliamperes to beyond 20 amperes of alternating or direct currents. See application note AN-209 for the basic principles of current sensing using AMR bridges.

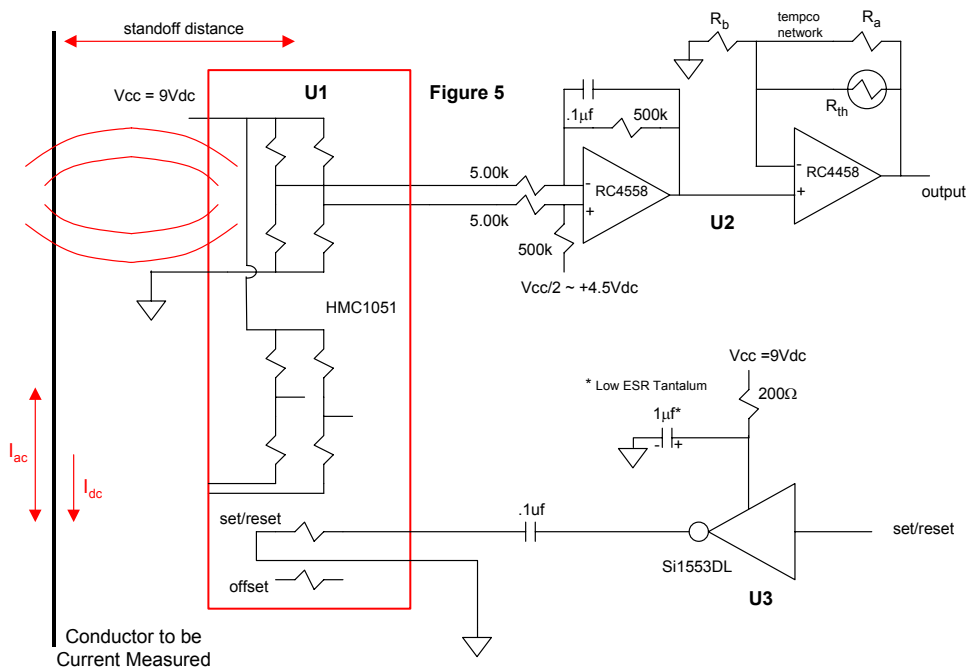

Three Axis Compassing with Tilt Compensation

For full three-axis compassing, the circuit depicted in Figure 6 shows both a HMC1051Z and a HMC1052 used for sensing the magnetic field in three axes. A two-axis accelerometer is also shown to provide pitch and roll (tilt) sensing to correct the three-axis data into the corrected two-axis heading. The accelerometer can be substituted with a fluidic 2-axis tilt sensor if desired. For lower voltage operation with Lithium battery supplies (2.5 to 3.6Vdc), the Set/Reset circuit should be upgraded from a single IRF7507 to the dual IRF7507 implementation to permit a minimum 1.0 ampere pulse (0.5 ampere per set/reset strap resistance) to both the HMC1052 and HMC1051 sensors.

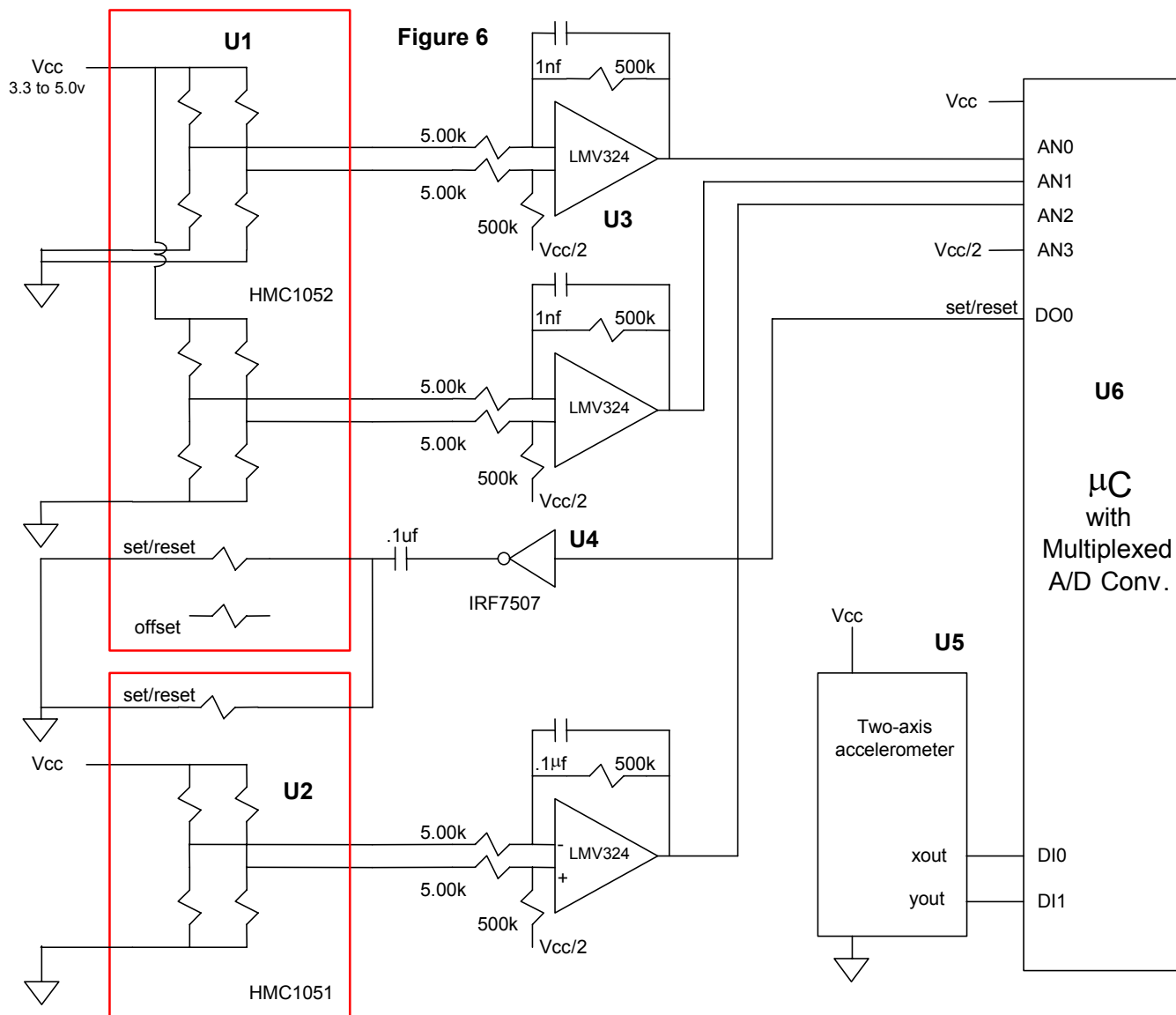

Duty Cycling for Lower Energy Consumption

For battery powered and other applications needing limited energy consumption, the sensor bridge and support electronics can be switched "off" between magnetic field measurements. The HMC1051Z and HMC1052 are very low capacitance (Bandwidth > 5MHz) sensor bridges and can stabilize typically before the support electronics can. Also minimizing the quantity of set/reset pulses will save energy too. Figure 7 shows a simple supply switching circuit that can be microprocessor controlled to duty cycle (toggle) the electronics in moderate current (<25mA) applications.

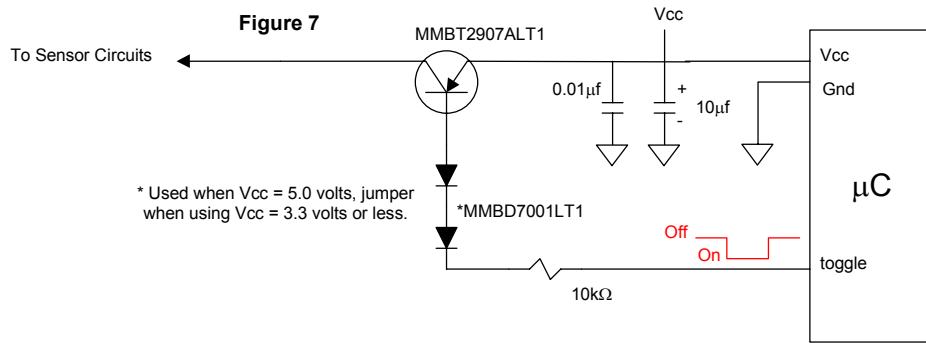

PACKAGE DRAWING 8-PIN SIP

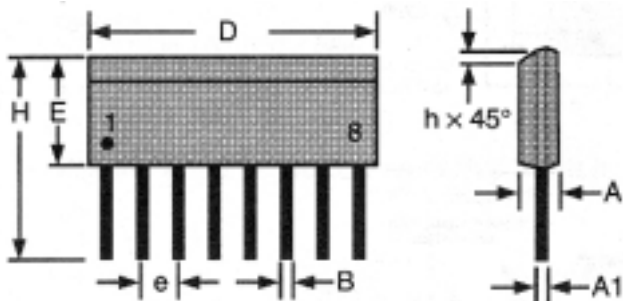

Symbol	Millimeters		Inches x 10E-3	
	Min	Max	Min	Max
A	1.371	1.728	54	68
A1	0.101	0.249	4	10
B	0.355	0.483	14	19
D	9.829	11.253	387	443
E	3.810	3.988	150	157
e	1.270 ref		50 ref	
H	6.850	7.300	270	287
h	0.381	0.762	15	30

PACKAGE DRAWING 10-PIN MSOP

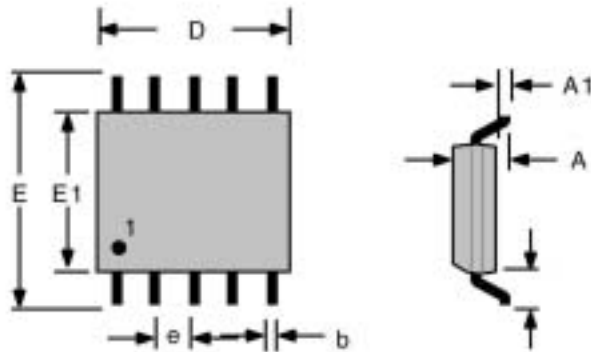

Symbol	Millimeters		Inches x 10E-3	
	Min	Max	Min	Max
A	-	1.10	-	43
A1	0.05	0.15	2.0	5.9
B	0.15	0.30	5.9	11.8
D	2.90	3.10	114	122
E1	2.90	3.10	114	122
e	0.50 BSC		2.0 BSC	
E	4.75	5.05	187	199
L1	0.95 BSC		37.4	

Ordering Information

Ordering Number	Product
HMC1051Z	One Axis Magnetic Sensor – SIP8 Package
HMC1052	Two Axis Magnetic Sensors – MSOP10

Honeywell reserves the right to make changes to improve reliability, function or design. Honeywell does not assume any liability arising out of the application or use of any product or circuit described herein; neither does it convey any license under its patent rights nor the rights of others.