

New

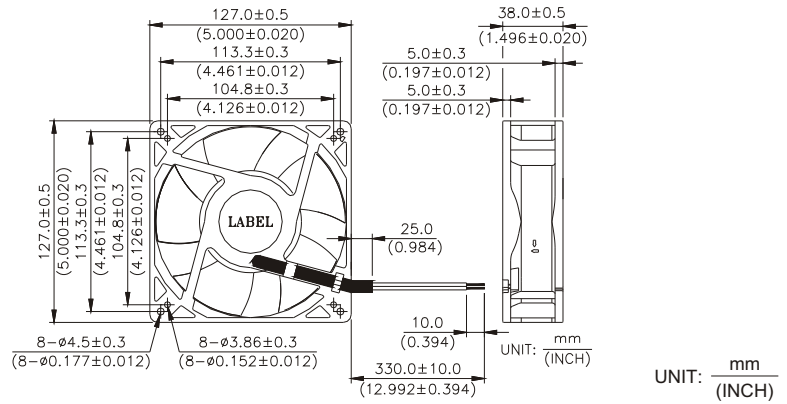

# AHB 127 x 127 x 38 MM SERIES

## DIMENSIONS DRAWING



- \* Bearing Type  
Ball Bearings
- \* Material  
Impeller : Plastic (UL 94V-0)  
Frame : Die-cast Aluminum
- \* Lead Wires :  
UL 1007 AWG #24 OR Equivalent  
Red Wire Positive (+)  
Black Wire Negative (-)
- \* Weight : 490g (17.28 oz)

## P & Q CURVE (AT RATED VOLTAGE)

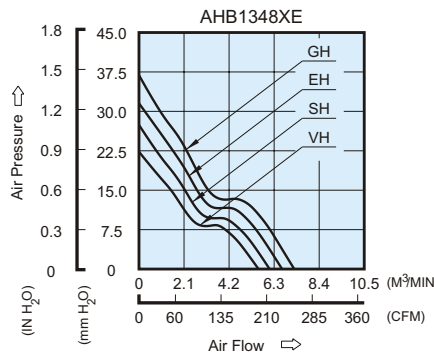

## MOUNTING PANEL CUTOUT

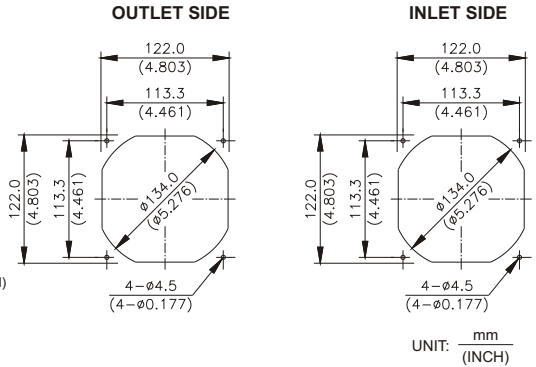

MODEL		Rated Voltage	Operating Voltage Range	Rated Current	Rated Input Power	Speed	Maximum Air Flow		Maximum Air Pressure		Noise
PART NO.	FUNCTION	VDC	VDC	Amp	Watt	R.P.M.	m <sup>3</sup> /min	CFM	mmH <sub>2</sub> O	IN H <sub>2</sub> O	dB-A
AHB1348VHE	-R00 / -F00	48	32.0 to 80.0	0.41	19.68	4300	5.573	196.82	22.39	0.881	60.5
AHB1348SHE	-R00 / -F00	48	32.0 to 80.0	0.49	23.52	4700	6.091	215.12	26.79	1.055	63.0
AHB1348EHE	-R00 / -F00	48	32.0 to 80.0	0.61	29.28	5100	6.660	235.20	31.41	1.237	65.0
AHB1348GHE	-R00 / -F00	48	32.0 to 80.0	0.75	36.00	5500	7.243	255.77	36.77	1.448	67.0

- \* Function type is optional.
- \* The max. air flow and the speed are measured in free air ; max. air pressure is measured at zero air flow.
- \* Noise is measured in anechoic chamber in free air, one meter from intake side.
- \* All readings are typical values at rated voltage.
- \* Specifications are subject to change without notice.

*New*

# AHB 172 x 150 x 25.4 MM SERIES

## DIMENSIONS DRAWING

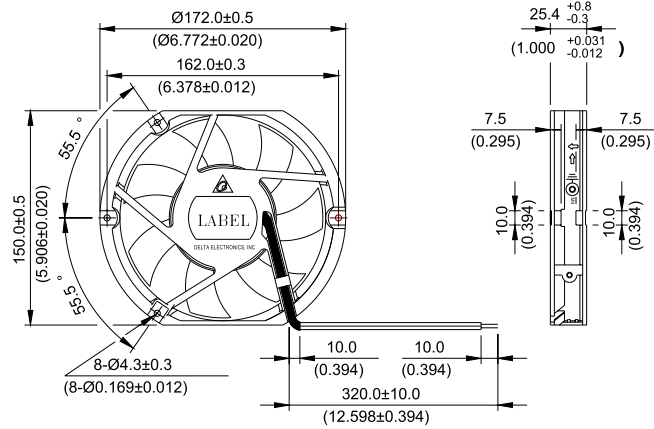

UNIT:  $\frac{\text{mm}}{\text{(INCH)}}$

- \* Bearing Type  
Ball Bearings
- \* Material  
Impeller : Plastic (UL 94V-0)  
Frame : Die-Cast Aluminum
- \* Lead Wires :  
UL 1007AWG#24 OR Equivalent  
Red Wire Positive (+)  
Black Wire Negative (-)
- \* Weight : 430g (15.17 oz)

## P & Q CURVE (AT RATED VOLTAGE)

## MOUNTING PANEL CUTOUT

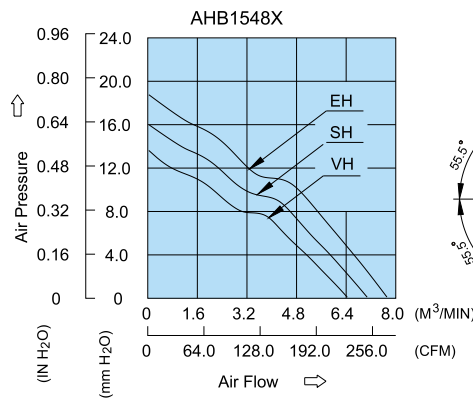

### OUTLET SIDE

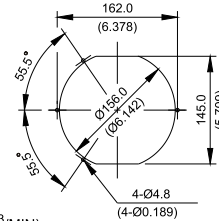

### INLET SIDE

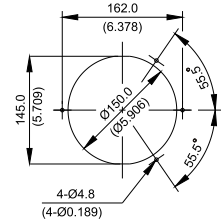

UNIT:  $\frac{\text{mm}}{\text{(INCH)}}$

MODEL		Rated Voltage	Operating Voltage Range	Rated Current	Rated Input Power	Speed	Maximum Air Flow		Maximum Air Pressure		Noise
PART NO.	FUNCTION	VDC	VDC	Amp	Watt	R.P.M.	m <sup>3</sup> /min	CFM	mmH <sub>2</sub> O	IN H <sub>2</sub> O	dB-A
AHB1548VH	-R00 / -F00	48	32.0 to 80.0	0.37	17.76	3400	6.408	226.31	13.62	0.536	56.0
AHB1548SH	-R00 / -F00	48	32.0 to 80.0	0.43	20.64	3700	7.059	249.27	16.10	0.634	59.0
AHB1548EH	-R00 / -F00	48	32.0 to 80.0	0.52	24.96	4000	7.675	271.05	18.69	0.736	61.0

\* Function type is optional.  
 \* The max. air flow and the speed are measured in free air ; max. air pressure is measured at zero air flow.  
 \* Noise is measured in anechoic chamber in free air, one meter from intake side.  
 \* All readings are typical values at rated voltage.  
 \* Specifications are subject to change without notice.

New



# AHB 172 x 150 x 50.8 MM SERIES

## DIMENSIONS DRAWING

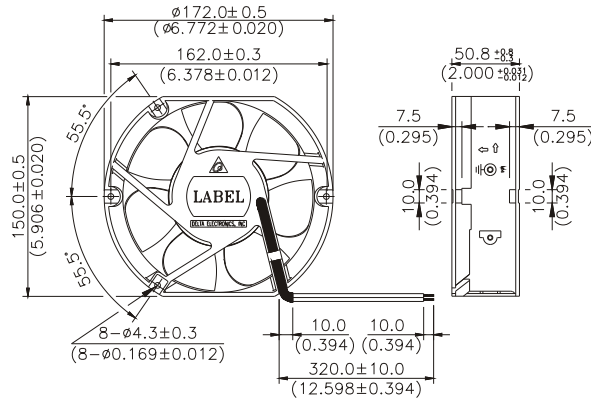

UNIT:  $\frac{\text{mm}}{\text{(INCH)}}$

- \* Bearing Type  
Ball Bearings
- \* Material  
Impeller : Plastic (UL 94V-0)  
Frame : Die-cast Aluminum
- \* Lead Wires :  
UL 1007 AWG #24 OR Equivalent  
Red Wire Positive (+)  
Black Wire Negative (-)
- \* Weight : 800g (28.22 oz)

## P & Q CURVE (AT RATED VOLTAGE)

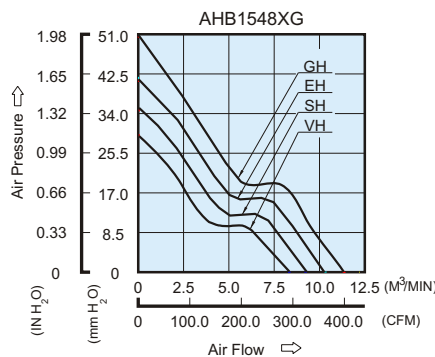

## MOUNTING PANEL CUTOUT

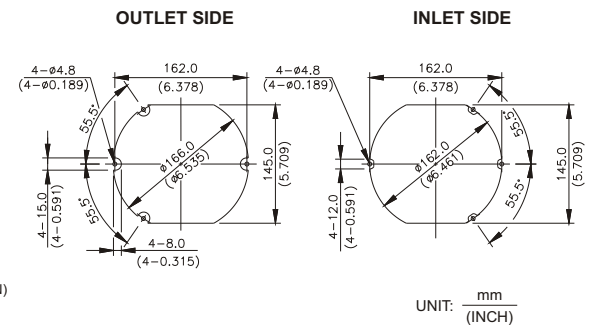

UNIT:  $\frac{\text{mm}}{\text{(INCH)}}$

MODEL		Rated Voltage	Operating Voltage Range	Rated Current	Rated Input Power	Speed	Maximum Air Flow		Maximum Air Pressure		Noise
PART NO.	FUNCTION	VDC	VDC	Amp	Watt	R.P.M.	m <sup>3</sup> /min	CFM	mmH <sub>2</sub> O	IN H <sub>2</sub> O	dB-A
AHB1548VHG	-R00 / -F00	48	32.0 to 80.0	0.71	34.08	4000	8.645	305.29	28.91	1.138	62.0
AHB1548SHG	-R00 / -F00	48	32.0 to 80.0	0.88	42.24	4400	9.526	336.41	34.69	1.366	64.0
AHB1548EHG	-R00 / -F00	48	32.0 to 80.0	1.22	58.56	4800	10.434	368.47	41.43	1.631	66.0
AHB1548GHG	-R00 / -F00	48	32.0 to 80.0	1.52	72.96	5200	11.404	402.72	49.88	1.964	68.5

- \* Function type is optional.
- \* The max. air flow and the speed are measured in free air ; max. air pressure is measured at zero air flow.
- \* Noise is measured in anechoic chamber in free air, one meter from intake side.
- \* All readings are typical values at rated voltage.
- \* Specifications are subject to change without notice.

*New*

# AHB Ø 172 x 25.4 MM SERIES

## DIMENSIONS DRAWING

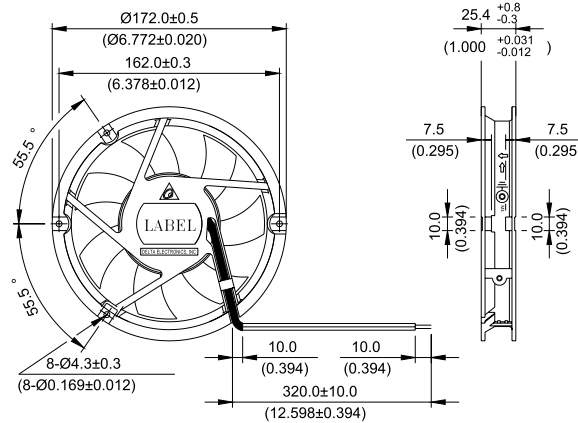

UNIT:  $\frac{\text{mm}}{\text{(INCH)}}$

- \* Bearing Type  
Ball Bearings
- \* Material  
Impeller : Plastic (UL 94V-0)  
Frame : Die-Cast Aluminum
- \* Lead Wires :  
UL 1007AWG#24 OR Equivalent  
Red Wire Positive (+)  
Black Wire Negative (-)
- \* Weight : 450g (15.87 oz)

## P & Q CURVE (AT RATED VOLTAGE)

## MOUNTING PANEL CUTOUT

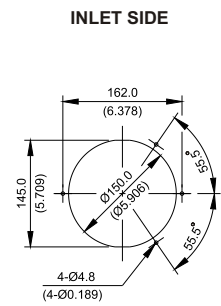
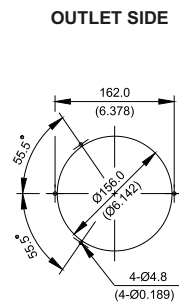
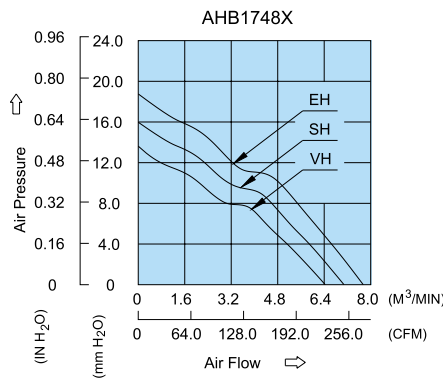

UNIT:  $\frac{\text{mm}}{\text{(INCH)}}$

MODEL		Rated Voltage	Operating Voltage Range	Rated Current	Rated Input Power	Speed	Maximum Air Flow		Maximum Air Pressure		Noise
PART NO.	FUNCTION	VDC	VDC	Amp	Watt	R.P.M.	m <sup>3</sup> /min	CFM	mmH <sub>2</sub> O	IN H <sub>2</sub> O	dB-A
AHB1748VH	-R00 / -F00	48	32.0 to 80.0	0.37	17.76	3400	6.408	226.31	13.62	0.536	56.0
AHB1748SH	-R00 / -F00	48	32.0 to 80.0	0.43	20.64	3700	7.059	249.27	16.10	0.634	59.0
AHB1748EH	-R00 / -F00	48	32.0 to 80.0	0.52	24.96	4000	7.675	271.05	18.69	0.736	61.0

\* Function type is optional.  
 \* The max. air flow and the speed are measured in free air ; max. air pressure is measured at zero air flow.  
 \* Noise is measured in anechoic chamber in free air, one meter from intake side.  
 \* All readings are typical values at rated voltage.  
 \* Specifications are subject to change without notice.

New



# AHB Ø172 x 50.8 MM SERIES

## DIMENSIONS DRAWING

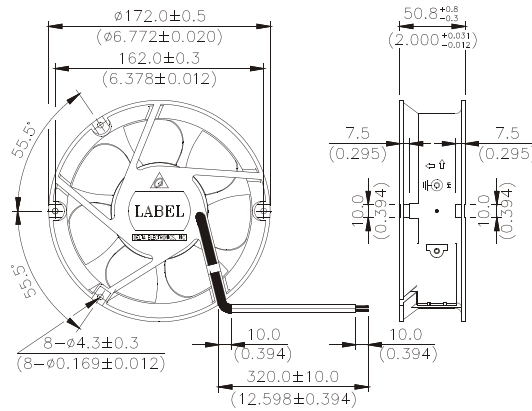

UNIT:  $\frac{\text{mm}}{\text{(INCH)}}$

- \* Bearing Type  
Ball Bearings
- \* Material  
Impeller : Plastic (UL 94V-0)  
Frame : Die-cast Aluminum
- \* Lead Wires :  
UL 1007 AWG #24 OR Equivalent  
Red Wire Positive (+)  
Black Wire Negative (-)
- \* Weight : 820g (28.93 oz)

## P & Q CURVE (AT RATED VOLTAGE)

## MOUNTING PANEL CUTOUT

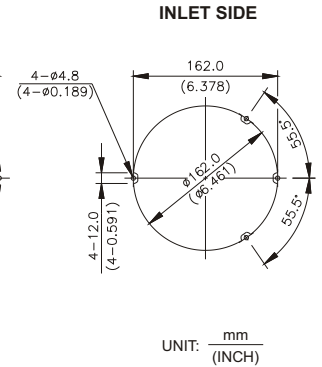
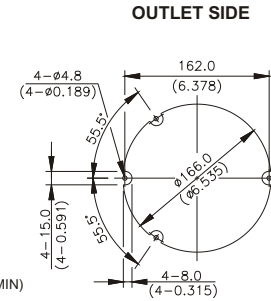
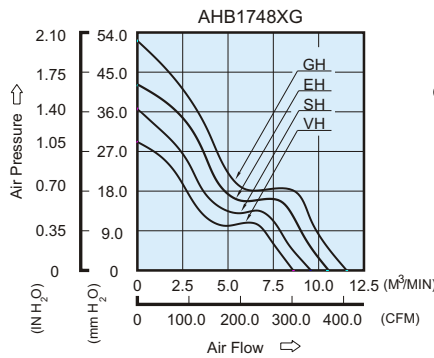

UNIT:  $\frac{\text{mm}}{\text{(INCH)}}$

MODEL		Rated Voltage	Operating Voltage Range	Rated Current	Rated Input Power	Speed	Maximum Air Flow		Maximum Air Pressure		Noise
PART NO.	FUNCTION	VDC	VDC	Amp	Watt	R.P.M.	m <sup>3</sup> /min	CFM	mmH <sub>2</sub> O	IN H <sub>2</sub> O	dB-A
AHB1748VHG	-R00 / -F00	48	32.0 to 80.0	0.71	34.08	4000	8.760	309.37	29.75	1.171	59.5
AHB1748SHG	-R00 / -F00	48	32.0 to 80.0	0.88	42.24	4400	9.773	345.13	36.34	1.431	61.5
AHB1748EHG	-R00 / -F00	48	32.0 to 80.0	1.22	58.56	4800	10.636	375.62	43.24	1.702	64.0
AHB1748GHG	-R00 / -F00	48	32.0 to 80.0	1.52	72.96	5200	11.564	408.39	52.02	2.048	66.5

\* Function type is optional.  
 \* The max. air flow and the speed are measured in free air ; max. air pressure is measured at zero air flow.  
 \* Noise is measured in anechoic chamber in free air, one meter from intake side.  
 \* All readings are typical values at rated voltage.  
 \* Specifications are subject to change without notice.