

SURFACE MOUNT COMMON MODE CHOKES

Suited for LAN and Telecom Applications

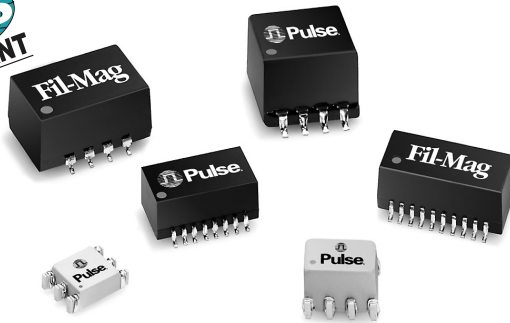
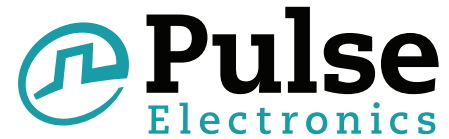

- Reduces radiated EMI emissions
- Filters common mode noise for EMI reduction
- Common mode attenuation from 100 kHz to 1 GHz
- Peak solder temperature ratings per table 5-2 in IPC/JEDEC J-STD-020

Electrical Specifications @ 25°C

Part Number	No. of Ports	Primary Inductance OCL (μH MIN)	Common Mode Attenuation (db TYP)									DCR (Ω MAX)
			100 KHz	1 MHz	10 MHz	30 MHz	50 MHz	100 MHz	300 MHz	500 MHz	1 GHz	
PE-68624NL ^{2a}	1	47	11	27	40	44	42	36	26	17	—	0.40
PE-65855NL ^{2a}	1	4700	41	43	49	39	34	26	20	20	12	1.0
PE-65857NL ^{2a}	4	22.5	7	20	30	37	38	34	24	13	—	0.22
PE-68627NL ^{2a}	4	24	8	21	32	36	37	36	30	20	—	0.25
PE-65854NL ^{2a}	4	47	3	19	32	36	35	29	12	6	—	0.40
PE-67540NL ^{2a}	4	100	14	33	44	48	49	44	34	29	20	0.60
T8008NL ^{2a}	8	47	7	27	40	44	42	36	26	—	—	0.40

1. For Tape & Reel packaging, add suffix "T" to the end of the part number e.g. T8008NLT
2. MSL = Moisture Sensitivity Level a=1 b=2 c=3 d=4

Mechanical

Schematic

PE-68624NL

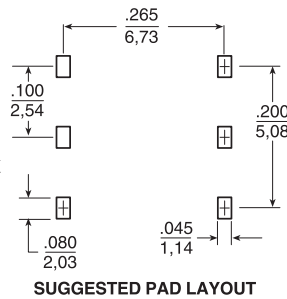
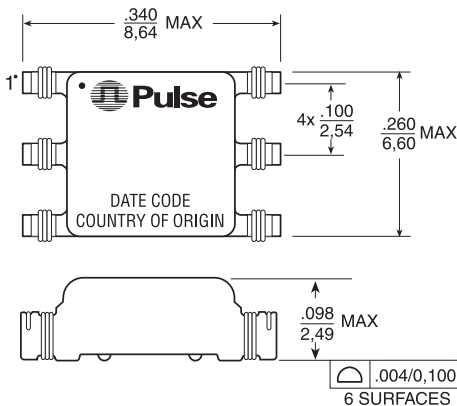

Weight 0.17 grams
Tape & Reel 1500/reel
Tube 85/tube

SURFACE MOUNT COMMON MODE CHOKES

Suited for LAN and Telecom Applications

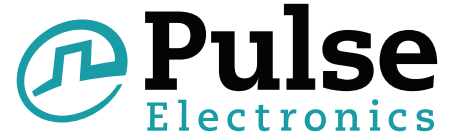

Mechanical

Schematic

PE-65854NL

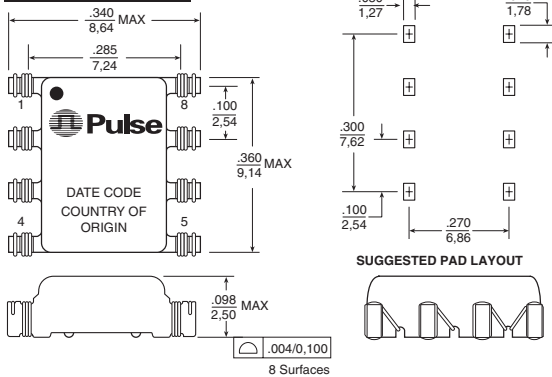

Dimensions: Inches
mm

Unless otherwise specified,
all tolerances are $\pm 0,10$
0,25

Weight 0.3 grams
Tape & Reel 1500/reel
Tube 60/tube

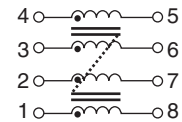

PE-65855NL

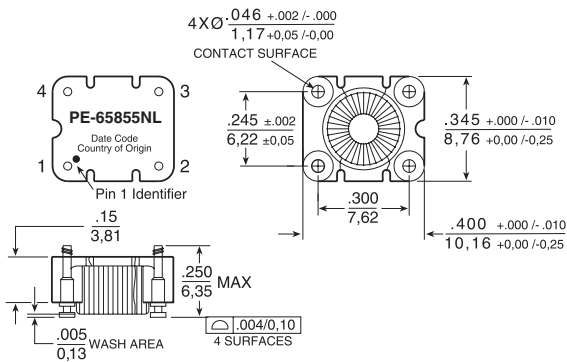

Dimensions: Inches
mm

Unless otherwise specified,
all tolerances are $\pm 0,10$
0,25

Weight 0.69 grams
Tape & Reel 800/reel
Tube 40 /tube



PE-65857NL, PE-67540NL

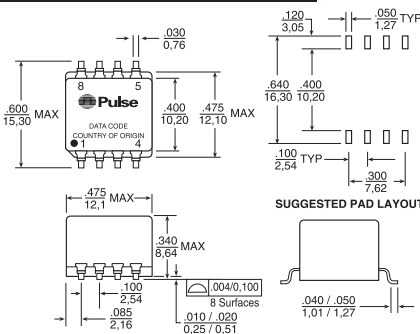

Dimensions: Inches
mm

Unless otherwise specified,
all tolerances are $\pm 0,10$
0,25

Weight 2.0 grams
Tape & Reel 250/reel
Tube 40/tube

PE-65857

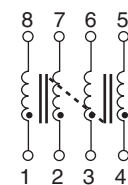

PE-67540

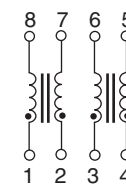

PE-68627NL

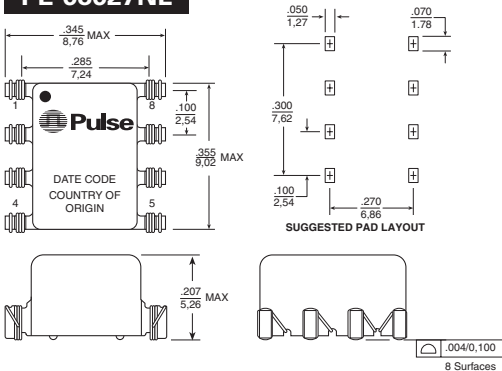

Dimensions: Inches
mm

Unless otherwise specified,
all tolerances are $\pm 0,10$
0,25

Weight 0.3 grams
Tape & Reel 1500/reel
Tube 55/tube

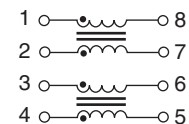

SURFACE MOUNT COMMON MODE CHOKES

Suited for LAN and Telecom Applications

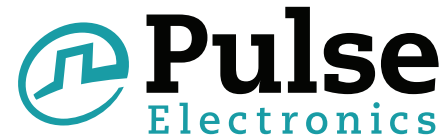

Mechanical

Schematic

T8008NL

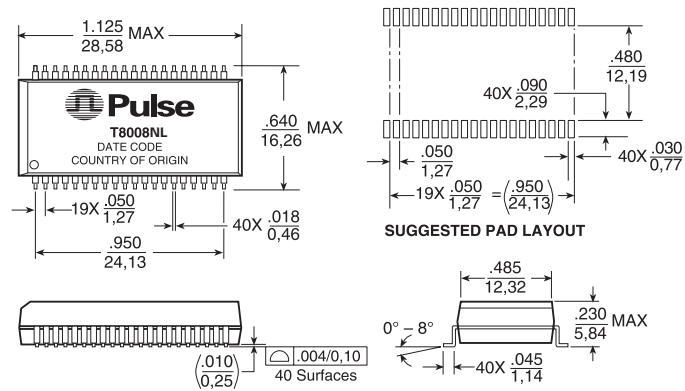

Dimensions: $\frac{\text{Inches}}{\text{mm}}$
Unless otherwise specified,
all tolerances are $\pm .010$
 $0,25$

Weight 4.0 grams
Tape & Reel 250/reel
Tube 15/tube

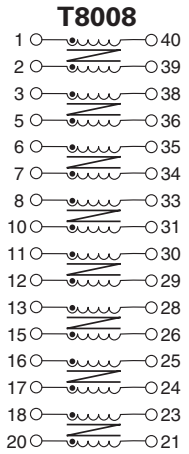

NOTE: The common mode test circuit for surface mount is the same as for through hole and is on the back page.

Common Mode Test Circuit for Surface Mount and Through Hole

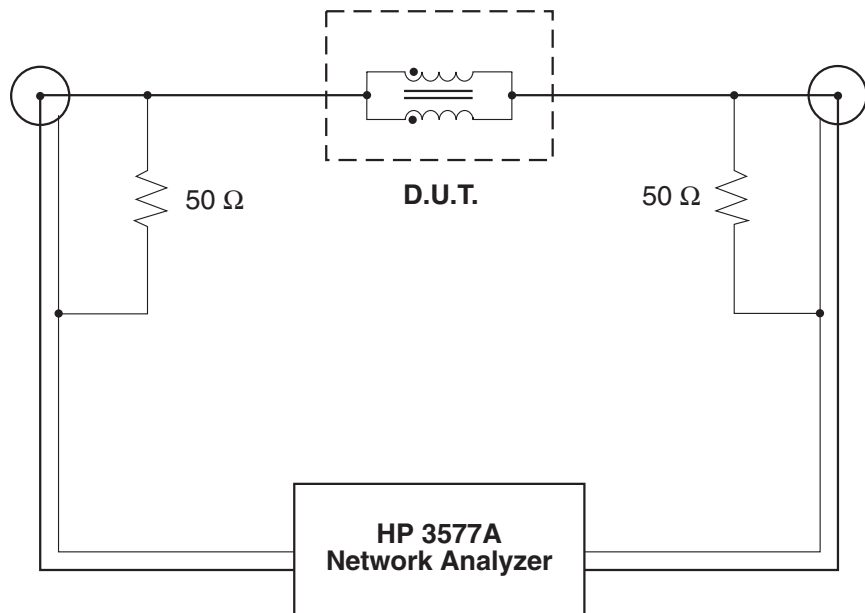

- Test Notes:**
1. Network analyzer calibrated to compensate for 50 Ω resistors.
 2. All windings on a core are connected in parallel for the test.
 3. For multi-core chokes, test data is for one core only. The windings on the other core(s) are left unconnected (i.e. open).

For More Information:

Pulse North America Headquarters	Pulse Europe	Pulse China Headquarters	Pulse North China	Pulse South Asia	Pulse North Asia
12220 World Trade Dr. San Diego, CA 92128 U.S.A.	Einsteinstrasse 1 D-71083 Herrenberg Germany	B402, Shenzhen Academy of Aerospace Technology Bldg. 10th Kejinan Rd. High-Tech Zone Nanshan District Shenzen, PR China 518057	Room 1503 XinYin Building No. 888 YiShan Rd. Shanghai 200233 China	135 Joo Seng Rd. #03-02 PM Industrial Bldg. Singapore 368363	No. 26, Kao Ching Rd. Yang Mei Chen Taoyuan Hsien Taiwan R. O. C.
Tel: 858 674 8100 Fax: 858 674 8262	Tel: 49 7032 7806 0 Fax: 49 7032 7806 135	TEL: 86 755 33966678 FAX: 86 755 33966700	Tel: 86 21 54643211/2 Fax: 86 21 54643210	TEL: 65 6287 8998 FAX: 65 6280 0080	Tel: 886 3 4643715 Fax: 886 3 4641911

Performance warranty of products offered on this data sheet is limited to the parameters specified. Data is subject to change without notice. Other brand and product names mentioned herein may be trademarks or registered trademarks of their respective owners. Pulse and the Squarewave logo are trademarks of Pulse Electronics, Inc., registered in the U.S. and other countries.
© Copyright, 2011. Pulse Electronics, Inc. All rights reserved.