

Altivar[®] 12 variable speed drives

For 3-phase motors from 0.18 to 4 kW

Catalog
2010



Schneider
Electric



Altivar® 12 variable speed drives

| | |
|--------------------------------------------------------|----------|
| Overview | 2 |
| <i>Selection guide</i> | <i>6</i> |
| Introduction | 8 |
| Specifications | 10 |
| References | 14 |
| Dimensions and mounting recommendations | 18 |
| Connections and installation recommendations | 22 |
| Combinations for customer assembly | 24 |
| Functions | 26 |

Altivar 12: Innovative drives technology ...



Small
Intuitive
Reliable
High-performance

The Altivar® 12 variable speed drive gives you greater reliability and simplicity of operation to run all your applications.

- The smallest drive with integrated EMC for compact machines
- Ever more intuitive and user-friendly programming and menus
- Can be configured with the power off, even in its packaging
- Designed to withstand even the harshest environments
- Quick and simple to set up
- No compromise on quality; components are designed to last 10 years



Collaborative design...

We surveyed our customers and users to determine their needs. The result is the innovative Altivar 12.

Make the most of your energySM

... combines efficiency with intelligence

The Altivar 12 is well-suited for use in applications involving simple industrial machines or certain consumer machines. Its compact size, high performance and discreet appearance make it particularly attractive for use in the following sectors:

- Food industry (ventilation of catering kitchens, bagging machines, bakers' kneading machines, greenhouses, etc.)
- Small handling applications (car washes, conveyors, etc.)
- Medical and health sector (medical beds, fitness machines)
- Machines with a single-phase socket (wood-working machines, surface polishing and cleaning machines, swimming pool or irrigation pumps, hydromassage bathtubs, etc.)
- New markets (solar applications, etc.)
- Simple mechanical applications (2-speed motors, DC motors, mechanical drives, etc.)



Designed for easy integration

- Upgrade your machines and make them more efficient. With its advanced functions (integrated PID, multi-speed), the Altivar 12 increases your productivity
- Communicate easily with all the other parts of your machine via the integrated universal Modbus[®] serial link
- Reduce the depth of your equipment. The baseplate-mounted version dissipates heat into the machine frame



Small

The small format and advanced functions of the Altivar 12 means that it can easily replace any existing drive in its category.



Economical

- Design: Save time by using the SoMove[™] configuration software workshop
- Commissioning: Quicker configuration with the "power off" download function
- Wiring and mounting: Quicker and easier installation with integrated Modbus communication

Altivar 12: High-performance plus easy integration and configuration...

Easy to integrate – the Altivar 12 is an extremely efficient drive. Its design and rugged components make it both reliable and durable.

No compromise on quality

- Higher performance for your motors with:
 - Factory settings that provide a high quality drive from the very first time the power is turned on
 - Integration of Standard (U/f), Performance (sensorless flux vector control, or SVC) and Pump/Fan (quadratic profile Kn^2) control profiles
 - High dynamic performance on acceleration as well as on braking
 - Excellent speed regulation on machine load surges
- Reduced noise and maintenance with:
 - No fan on models up to 0.75 kW at 240 V
 - Cassette type fan, operates automatically on detection of specific temperature setting
- Designed for easy fitting and wiring:
 - Using a single tool
 - Power terminals not tightened, ready for wiring
 - Easy access angles
 - Numerous, easy-to-identify markings
- Fast detection and protection against motor current peaks associated with certain applications (motor switching, catching-on-the-fly, etc.)
- Perfect integration of single-phase 240 V model into the electrical network, thanks to its built-in EMC filter



Fan can be changed without the need for any tools.



Practical, recyclable packaging. You can configure your product in its packaging without breaking the guarantee seal.



Sturdy

- New generation long-life components (10-year service life under normal operating conditions)
- Cards coated (standard). Resistance to disturbed power supplies has been increased to withstand harsh environments



Easy to identify

- All identification markings on the product are on a hinged door on front panel
- Easy identification of connections



Green

- Average 30% energy savings (with the Pump/Fan control profile) for the majority of applications
- Less cardboard to be recycled - only one box is used for bulk orders



...lets you communicate intuitively with your applications

The Altivar® 12 variable speed drive is immediately operational. It's configured using its notched wheel or from the SoMove software workshop. The file that is generated can be downloaded to the product even while it is still in its packaging, using the Multi-Loader console.

Save time on commissioning

- Drive can be configured before it is received (by the distributor), during storage (by the storekeeper) or during fitting before electrical enclosure is powered up for the first time
- No adjustment required. A quick start guide is provided for immediate setup
- Work in the language of your choice with the SoMove software workshop, that can be downloaded free of charge from: **www.schneider-electric.us**
- Select the functions you need from the menu
- Bluetooth® wireless connection option for PC available for greater ease of use

Save time on programming

- Navigation button provides easy menu access. You can set the parameters of your application with just a few clicks
- Three-level tree structure
 - Reference Mode: In local operation (On/Off buttons) and for speed adjustment and display
 - Monitoring Mode: For displaying parameters
 - Configuration Mode: For configuring your applications and settings

Save time on wiring

- Easy access to all wiring and adjustment functions on front panel via sealable hinged door
- Integrated EMC filter in 240 V single-phase versions
- No need to remove terminal cover to wire power section
- Only one screwdriver needed for wiring both the control and power sections
- Less wiring needed with integrated Modbus communication



Fast

With the Multi-Loader console you can configure 10 drives in their packaging is less than 5 minutes, with no power supply!



Versatile

The Altivar 12 VFD range is designed for 120 to 240 V power supplies. For your specific requirements in multiple applications, see the complete Altivar® range on our website:

www.schneider-electric.us



Use SoMove™ configuration software to customize your menus and save time during operation (possible for up to 25 parameters)

| Type of machine | Simple machines | | Pumps and fans (building (HVAC)) (1) |
|-----------------------------------------------------|-------------------------------------------------------------------------------------------------------------|----------------------------------------------------------------------------------------------------------------------|-----------------------------------------------------------------------------------------------|
| |  |  |  |
| Power range for 50 to 60 Hz (kW) line supply | 0.18 to 4 | 0.18 to 15 | 0.75 to 75 |
| Single-phase 100 to 120 V (kW) | 0.18 to 0.75 | – | – |
| Single-phase 200 to 240 V (kW) | 0.18 to 2.2 | 0.18 to 2.2 | – |
| Three-phase 200 to 230 V (kW) | – | – | – |
| Three-phase 200 to 240 V (kW) | 0.18 to 4 | 0.18 to 15 | 0.75 to 30 |
| Three-phase 380 to 480 V (kW) | – | – | 0.75 to 75 |
| Three-phase 380 to 500 V (kW) | – | 0.37 to 15 | – |
| Three-phase 500 to 600 V (kW) | – | – | – |
| Three-phase 525 to 600 V (kW) | – | 0.75 to 15 | – |
| Three-phase 500 to 690 V (kW) | – | – | – |
| Drive | Output frequency | 0.1 to 400 Hz | 0.1 to 500 Hz |
| Type of control | Asynchronous motor | Standard (voltage/frequency) Performance (sensorless flux vector control) Pump/fan (Kn ² quadratic ratio) | Standard (voltage/frequency) Performance (sensorless flux vector control) Energy saving ratio |
| | Synchronous motor | – | Sensorless flux vector control Voltage/frequency ratio (2 points) Energy saving ratio |
| Transient overtorque | 150 to 170% of the nominal motor torque | 170 to 200% of the nominal motor torque | 120% of the nominal motor torque |
| Functions | Number of functions | 40 | 50 |
| Number of preset speeds | 8 | 16 | 7 |
| Number of I/O | Analog inputs | 1 | 3 |
| | Logic inputs | 4 | 6 |
| | Analog outputs | 1 | 1 |
| | Logic outputs | 1 | – |
| | Relay outputs | 1 | 2 |
| Communication | Embedded | Modbus® | Modbus |
| | As an option | – | LonWorks, METASYS N2, APOGEE FLN, BACnet |
| Cards (available as an option) | – | – | – |
| Dialog tools | IP 54 or IP 65 remote terminal | IP 54 or IP 65 remote terminal IP 54 remote graphic display terminal | IP 50 remote terminal |
| Configuration tools | SoMove setup software Simple Loader and Multi-Loader configuration tools | – | PCSoft setup software for ATV21 |
| Standards and certifications | IEC/EN 61800-5-1, IEC/EN 61800-3 (environments 1 and 2, categories C1 to C3) CE, UL, CSA, C-Tick, NOM, GOST | – | EN 55011: Group 1, class A and class B with option card. CE, UL, CSA, C-Tick, NOM |
| References | ATV12 | ATV312 | ATV21 |
| Pages | 14 | Please refer to the "Altivar 312 variable speed drives" catalog | Please refer to the "Altivar 21 variable speed drives" catalog |

(1) Heating Ventilation Air Conditioning



See more technical information online at www.schneider-electric.us

**Pumps and fans
(industrial)**



Complex machines



| |
|-----------------------------------------------------------------------------------------------------------------------------------------------------------------------------|
| 0.37 to 800 |
| – |
| 0.37 to 5.5 |
| – |
| 0.75 to 90 |
| 0.75 to 630 |
| – |
| 2.2 to 7.5 |
| – |
| 2.2 to 800 |
| 0.1 to 500 Hz for the entire range 0.1 to 599 Hz up to 37 kW at 200 to 240 V ~ and 380 to 480 V ~ |
| Sensorless flux vector control Voltage/frequency ratio (2 or 5 points) Energy saving ratio |
| Vector control without speed feedback 120% of the nominal motor torque for 60 seconds |
| > 100 |
| 8 |
| 2 to 4 |
| 6 to 20 |
| 1 to 3 |
| 0 to 8 |
| 2 to 4 |
| Modbus and CANopen Modbus TCP Daisy Chain, Modbus/Uni-Telway, EtherNet/IP, DeviceNet, PROFIBUS DP V0 and V1, INTERBUS, CC-Link, LonWORKS, METASYS N2, APOGEE FLN, BACnet |
| I/O extension cards, "Controller Inside" programmable card, multi-pump cards, encoder interface cards |
| IP 54 or IP 65 remote graphic display terminal |
| SoMove setup software Simple Loader and Multi-Loader configuration tools |
| IEC/EN 61800-5-1, IEC/EN 61800-3 (environments 1 and 2, C1 to C3), IEC/EN 61000-4-2/4-3/4-4/4-5/4-6/4-11 CE, UL, CSA, DNV, C-Tick, NOM, GOST |

| |
|--------------------------------------------------------------------------------------------------------------------------------------------------------|
| 0.37 to 630 |
| – |
| 0.37 to 5.5 |
| – |
| 0.37 to 75 |
| 0.75 to 500 |
| – |
| 1.5 to 7.5 |
| – |
| 1.5 to 630 |
| 0.1 to 500 Hz for the entire range 0.1 to 599 Hz up to 37 kW at 200 to 240 V ~ and 380 to 480 V ~ |
| Flux vector control with or without sensor Voltage/frequency ratio (2 or 5 points) ENA System |
| Vector control with or without speed feedback 220% of nominal motor torque for 2 seconds 170% for 60 seconds |
| > 150 |
| 16 |
| 2 to 4 |
| 6 to 20 |
| 1 to 3 |
| 0 to 8 |
| 2 to 4 |
| Modbus TCP Daisy Chain, Modbus/Uni-Telway, EtherNet/IP, DeviceNet, PROFIBUS DP V0 and V1, INTERBUS, CC-Link |
| Interface cards for incremental, resolver, SinCos, SinCos Hiperface®, EnDat® or SSI encoders, I/O extension cards, Controller Inside programmable card |

ATV61

Please refer to the "Altivar 61 variable speed drives" catalog

ATV71

Please refer to the "Altivar 71 variable speed drives" catalog



ATV12 drive controlling an access barrier



ATV12 drive controlling a mixer



ATV12 drive controlling a pumping station

Introduction

The Altivar® 12 drive is a frequency inverter for three-phase 200 to 240 V asynchronous motors rated from 0.18 kW to 4 kW.

Easy Plug & Play installation, compact size, integrated functions and alternative base plate version make it particularly suitable for applications involving simple industrial machines and certain consumer machines.

By considering the constraints governing installation and use at the product design stage, we have been able to offer a reliable, cost-effective solution to manufacturers of compact simple machines (OEMs) and installers.

The Altivar 12 variable speed drive features:

- Drive factory-configuration for start-up without the need for any adjustment
- Multi-Loader configuration tool for loading a configuration onto the drive without taking it out of its packaging
- Labelled terminals to reduce wiring time; drive identification on the front panel
- Alternative delivery option of multiple units in a single special package (1). For example... with the individually-shipped drives, it is possible to load a configuration into each drive without taking them out of the packaging.

Applications

Applications for simple industrial machines

- Handling (small conveyors, etc.)
- Packaging (small labelling machines, small bagging machines, etc.)
- Pumping applications (suction pumps, centrifugal pumps, circulating pumps, mono-pump and multi-pump stations, etc.)
- Machines equipped with a fan (air or smoke extraction, plastic film making machines, ovens, boilers, washing machines, etc.)

Applications for consumer machines

- Handling (access barriers, rotating advertising hoardings, etc.)
- Machines for health-related areas (medical beds, hydromassage equipment, running machines, etc.)
- Food and beverage industry machines (mills, kneading machines, mixers, etc.)

Other types of application

- Food and beverage industry (battery farming, greenhouses, etc.)
- Miscellaneous applications (mobile machines and small appliances equipped with a power socket, etc.)
- Applications which traditionally use other solutions:
 - 2-speed motor, DC motor, mechanical drive, etc.
 - Single-phase motor for pump and fan applications using mechanical control; the "Altivar 12 + three-phase motor" solution adapts the power to the requirements of the driving application, thus reducing energy consumption.

Functions

In addition to the functions usually available on this type of drive, the Altivar 12 drive also features the following:

- Switching between local control and control via the terminals
- Motor control profiles: standard, performance and pump/fan
- Frequency skip
- Preset speeds
- PID regulator
- S ramp, U ramp, ramp switching
- Freewheel stop, fast stop
- Jog operation
- Configuring the logic and analog I/O
- Underload and overload detection
- Viewing the state of the logic inputs on the drive display
- Configuring how the parameters are displayed
- Error log, etc.

(1) Depending on the model (see page 14)

Altivar® 12 variable speed drives



Drive with heatsink
ATV12H075M2



Drive on base plate
ATV12P075M2

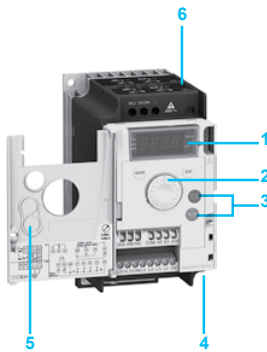

ATV12H075M2 with door on
front panel open



Multi-Loader
configuration tool



Remote terminal
with cover closed



Remote terminal with cover
open: RUN, FWD/REV and
STOP buttons accessible

An optimum solution

The Altivar® 12 range of variable speed drives extends across a range of motor power ratings from 0.18 kW to 4 kW on three types of power supply. Two standard versions are available:

Drive with heatsink for normal environments and fan-cooled enclosure:

□ 100 to 120 V single-phase, 0.18 kW to 0.75 kW (**ATV12H●●●F1**)

□ 200 to 240 V single-phase, 0.18 kW to 2.2 kW (**ATV12H●●●M2**)

□ 200 to 240 V three-phase, 0.18 kW to 4 kW (**ATV12H●●●M3**)

Drive on a base plate for mounting on the machine frame; the frame surface area should allow heat to dissipate:

□ 100 to 120 V single-phase, 0.18 kW to 0.37 kW (**ATV12H018F1, P037F1**)

□ 200 to 240 V single-phase, 0.18 kW to 0.75 kW (**ATV12H018M2, P●●●M2**)

□ 200 to 240 V three-phase, 0.18 kW to 4 kW (**ATV12H018M3, P●●●M3**)

Note: The Altivar 12 drive output voltage is 200 to 240 V three-phase, regardless of the type of drive line supply.

The Altivar 12 drive utilizes standard Modbus communication protocol, and can be accessed via the RJ45 connector located on the underside of the drive **4**.

The entire range conforms to international standards IEC/EN 61800-5-1 and IEC/EN 61800-3, is UL, CSA, C-Tick, NOM, GOST certified and has been developed to meet the requirements of directives regarding the protection of the environment (RoHS, WEEE) as well as those of European Directives to obtain the CE mark.

Electromagnetic compatibility (EMC)

The integration of a level C1 EMC filter in ATV12●●●M2 drives and the handling of EMC simplify installation and make it very inexpensive to bring the device into conformity to obtain the CE mark.

This EMC filter can be disconnected via an internal switch **6**.

ATV12●●●F1 and ATV12●●●M3 drives are designed without an EMC filter. Filters are available as an option and can be installed by the customer to reduce the level of emissions (see page 16).

External accessories and options

External accessories and options can be used with Altivar 12 drives:

EMC conformity kits, plates for direct mounting on 35 mm DIN rails, etc.

Braking units combined with a braking resistor, motor chokes, additional EMC input filters, etc.

Dialog and configuration tools

Human/Machine Interface (HMI)

The 4-digit display **1** can be used to display states and faults, access parameters and modify them via the navigation button **2**.

The RUN and STOP buttons **3** can be made accessible on the front panel by removing the blanking plate **5** from the door; they must be configured in order to be active.

Simple Loader and Multi-Loader configuration tools

The Simple Loader tool enables one powered-up drive's configuration to be duplicated on another powered-up drive.

The Multi-Loader tool enables configurations from a PC or drive to be copied and duplicated on another drive; the drives do not need to be powered up.

SoMove™ setup software

The SoMove setup software can be used with the Altivar 12 drive for configuration, adjustment, debugging (using the Oscilloscope function) and maintenance, just as it can for all other Schneider Electric variable speed drives and starters. It can also be used to customize the integrated display terminal menus. It can be used with a direct connection or a Bluetooth® wireless connection.

Remote display terminal

The Altivar 12 drive can be connected to a remote display terminal, available as an option. This terminal can be mounted on an enclosure door with IP 54 or IP 65 degree of protection. The maximum operating temperature is 50°C. It provides access to the same functions as the Human/Machine Interface.

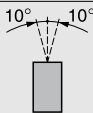
| Environmental specifications | | | |
|-----------------------------------------------------------------------------------------------------------|-----------------------------------------------------|---------------------------------------------------------------------------------------|----------------------------------------------------------------------------------------------------------------------------------------------------------------------------------------------------------------------------------------------------------------------------------------------------------------------------------------------------------------------------------------------------------------------------------------------------------------------------------------------------------------------------------------------------------------------------------------------------------------------------------------------------------------------------------------------------------------------------------------------------------------------------------------------------------------------------------------------------------------------------------------------------------------|
| Conformity to standards | | | Altivar® 12 drives have been developed to conform to the strictest international standards and the recommendations relating to electrical industrial control equipment (IEC, EN), in particular: IEC/EN 61800-5-1 (low voltage), IEC/EN 61800-3 (conducted and radiated EMC immunity and emissions). |
| EMC immunity | | | IEC/EN 61800-3, Environments 1 and 2 (EMC requirements and specific test methods) IEC/EN 61000-4-2 level 3 (electrostatic discharge immunity test) IEC/EN 61000-4-3 level 3 (radiated, radio-frequency, electromagnetic field immunity test) IEC/EN 61000-4-4 level 4 (electrical fast transient/burst immunity test) IEC/EN 61000-4-5 level 3 (surge immunity test) IEC/EN 61000-4-6 level 3 (immunity to conducted disturbances, induced by radio-frequency fields) IEC/EN 61000-4-11 (voltage dips, short interruptions and voltage variations immunity tests) |
| Conducted EMC emissions for drives | ATV12●●●●F1 ATV12H018M3 ATV12●037M3 to ●U22M3 | | With additional EMC filter: IEC/EN 61800-3, Environment 1 (public network) in restricted distribution: □ Category C1, from 4 to 12 kHz for a shielded motor cable length ≤ 5 m (except ATV12●018M3 to ●075M3) □ Category C2, from 4 to 12 kHz for a shielded motor cable length ≤ 20 m IEC/EN 61800-3, Environment 2 (industrial network): □ Category C3, from 4 to 12 kHz for a shielded motor cable length ≤ 20 m |
| | ATV12●●●●M2 | | IEC/EN 61800-3, Environment 1 (public network) in restricted distribution: □ Category C1, at 2, 4, 8, 12 and 16 kHz for a shielded motor cable length ≤ 5 m □ Category C2: ATV12H018M2 to ●075M2, from 2 to 12 kHz for a shielded motor cable length ≤ 5 m and at 2, 4, 16 kHz for a shielded motor cable length ≤ 10 m □ Category C2: ATV12HU15M2 to HU22M2, from 4 to 16 kHz for a shielded motor cable length ≤ 5 m and at 2, 4, 8, 12 and 16 kHz for a shielded motor cable length ≤ 10 m With additional EMC filter: IEC/EN 61800-3, Environment 1 (public network) in restricted distribution: □ Category C1, from 4 to 12 kHz for a shielded motor cable length ≤ 20 m □ Category C2, from 4 to 12 kHz for a shielded motor cable length ≤ 50 m IEC/EN 61800-3, Environment 2 (industrial network): □ Category C3, from 4 to 12 kHz for a shielded motor cable length ≤ 50 m |
| Radiated EMC emissions for drives | ATV12●●●●●● | | IEC/EN 61800-3, Environment 1 (public network) in restricted distribution: □ Category C2, from 2 to 16 kHz for a shielded motor cable |
| CE marking | | | The drives are marked CE according to the European low voltage (2006/95/EC) and EMC (2004/108/EC) directives |
| Product certifications | | | UL, CSA, NOM, GOST and C-Tick |
| Degree of protection | | | IP 20 |
| Vibration resistance | Drive not mounted on DIN rail | | According to IEC/EN 60068-2-6: □ 1.5 mm peak from 3 to 13 Hz □ 1 gn from 13 to 200 Hz |
| Shock resistance | | | 15 gn for 11 ms according to IEC/EN 60068-2-27 |
| Maximum ambient pollution Definition of insulation | | | Degree 2 according to IEC/EN 61800-5-1 |
| Environmental conditions Use | | | IEC 60721-3-3 classes 3C3 and 3S2 |
| Relative humidity | | % | 5 to 95 non condensing, no dripping water, according to IEC 60068-2-3 |
| Ambient air temperature around the device | Operation | ATV12H018F1, H037F1 ATV12H018M2 to H075M2 ATV12H018M3 to H075M3 ATV12P●●●●●● | °C - 10 to + 40 without de-rating (1) Up to + 60, with the protective blanking cover removed (1) and current de-rating of 2.2% per additional degree (2) |
| | | ATV12H075F1 ATV12HU15M2, HU22M2 ATV12HU15M3 to HU40M3 | °C - 10 to + 50 without de-rating Up to + 60, with the protective blanking cover removed (1) and current de-rating of 2.2% per additional degree (2) |
| | Storage | ATV12●●●●●● | °C - 25 to + 70 |
| Maximum operating altitude | | ATV12●●●●●● | m 1000 without de-rating |
| | | ATV12●●●●F1 | m Up to 2000 for single-phase networks and corner grounded distribution networks, with current de-rating of 1% per additional 100 m |
| | | ATV12●●●●M2 | m Up to 3000 meters for three-phase networks, with current de-rating of 1% per additional 100 m |
| | | ATV12●●●●M3 | m Up to 3000 meters for three-phase networks, with current de-rating of 1% per additional 100 m |
| Operating position Maximum permanent angle in relation to the normal vertical mounting position | | |  |

(1) See the possible mounting types on page 21.

(2) See the de-rating curves in the User Manual, available on our website at "www.schneider-electric.us".

| Drive specifications | | |
|----------------------------------|-----|-------------------------------------------------------------------------------------------------------------------------------------------------------------------------------------------------------------------------------------------------------------------------------------------------------------------------------------------------------------------------------------------------------------------------------------------------------------------------------------------------------------|
| Output frequency range | Hz | 0.5 to 400 |
| Configurable switching frequency | kHz | Nominal switching frequency: 4 kHz without de-rating in continuous operation Adjustable during operation from 2 to 16 kHz Above 4 kHz in continuous operation, apply de-rating to the nominal drive current of: 10% for 8 kHz 20% for 12 kHz 30% for 16 kHz Above 4 kHz, the drive will reduce the switching frequency automatically in the event of excessive temperature rise. See the de-rating curves in the User Manual, available on our website at "www.schneider-electric.us". |
| Speed range | | 1 to 20 |
| Transient overtorque | | 150 to 170% of the nominal torque depending on the drive rating and the type of motor |
| Braking torque | | Up to 70% of the nominal torque without resistor Up to 150% of the nominal motor torque with braking unit (optional) at high inertia |
| Maximum transient current | | 150% of the nominal drive current for 60 seconds |
| Motor control profiles | | Standard profile (voltage/frequency ratio) Performance profile (sensorless flux vector control) Pump/fan profile (Kn ² quadratic ratio) |

| Electrical power specifications | | | |
|-----------------------------------------------------|--------------------------------------------------------------------------------------|-----|------------------------------------------------------------------------------------------------------------------------------------------------------------------|
| Power supply | Voltage | V | 100 - 15% to 120 + 10% single-phase for ATV12●●●●F1 200 - 15% to 240 + 10% single-phase for ATV12●●●●M2 200 - 15% to 240 + 10% three-phase for ATV12●●●●M3 |
| | Frequency | Hz | 50 to 60 ± 5% |
| | Isc (short-circuit current) | A | ≤ 1000 (Isc at the connection point) for single-phase power supply ≤ 5000 (Isc at the connection point) for three-phase power supply |
| Drive supply and output voltages | | | Drive supply voltage |
| | ATV12●●●●F1 | V | 100 to 120 single-phase |
| | ATV12●●●●M2 | V | 200 to 240 single-phase |
| | ATV12●●●●M3 | V | 200 to 240 three-phase |
| Maximum length of motor cable (including tap links) | Shielded cable | m | 50 |
| | Unshielded cable | m | 100 |
| Drive noise level | ATV12H018F1, H037F1 ATV12H018M2 to H075M2 ATV12H018M3 to H075M3 ATV12P●●●●● | dBA | 0 |
| | ATV12H075F1 ATV12HU15M2, HU22M2 | dBA | 45 |
| | ATV12HU15M3 to HU40M3 | dBA | 50 |
| | | | |
| Electrical isolation | | | Electrical isolation between power and control (inputs, outputs, power supplies) |

| Connection specifications (drive terminals for the line supply, the motor output and the braking unit) | | | |
|-----------------------------------------------------------------------------------------------------------|--------------------------------------------------------------------------------------------------------------------------------------|--|--------------------------------------------------|
| Drive terminals | | | R/L1, S/L2/N, T/L3, U/T1, V/T2, W/T3, PA/+, PC/- |
| Maximum wire size and tightening torque | ATV12H018F1, H037F1 ATV12H018M2 to H075M2 ATV12H018M3 to H075M3 ATV12P037F1 ATV12P037M2 to P075M2 ATV12P037M3, P075M3 | | 3.5 mm ² (12 AWG) 0.8 Nm |
| | ATV12H075F1 ATV12HU15M2, HU22M2 ATV12HU15M3 to HU40M3 ATV12PU15M3 to PU40M3 | | 5.5 mm ² (10 AWG) 1.2 Nm |

| Electrical specifications (control) | | |
|---------------------------------------------|-------------------------|----------------------------------------------------------------------------------------------------------------------------------------------------------------------------------------------------------------------------------------------------------------------------------------------------------------------------------------------------------------------------------------------------------------------------------------------------------------------------------------------------------------------------------------------------------------------------------------------------------|
| Available internal supplies | | Protected against short-circuits and overloads: One 5 V \pm supply ($\pm 5\%$) for the reference potentiometer (2.2 to 10 k Ω), maximum data rate 10 mA One 24 V \pm supply ($-15\%/+20\%$) for the control inputs, maximum data rate 100 mA |
| Analog input | AI1 | 1 software-configurable voltage or current analog input: Voltage analog input: 0 to 5 V \pm (internal power supply only) or 0 to 10 V \pm , impedance 30 k Ω Analog current input: X-Y mA by programming X and Y from 0 to 20 mA, impedance 250 Ω Sampling time: < 10 ms Resolution: 10 bits Accuracy: $\pm 1\%$ at 25°C Linearity: $\pm 0.3\%$ of the maximum scale value Factory setting: Input configured as voltage type |
| Analog output | AO1 | 1 software-configurable voltage or current analog output: Analog voltage output: 0 to 10 V \pm , minimum load impedance 470 Ω Analog current output: 0 to 20 mA, maximum load impedance 800 Ω Update time: < 10 ms Resolution: 8 bits Accuracy: $\pm 1\%$ at 25°C |
| Relay outputs | R1A, R1B, R1C | 1 protected relay output, 1 N/O contact and 1 N/C contact with common point Response time: 30 ms maximum Minimum switching capacity: 5 mA for 24 V \pm Maximum switching capacity: On resistive load ($\cos \varphi = 1$ and L/R = 0 ms): 3 A at 250 V \sim or 4 A at 30 V \pm On inductive load ($\cos \varphi = 0.4$ and L/R = 7 ms): 2 A at 250 V \sim or 30 V \pm |
| LI logic inputs | LI1 to LI4 | 4 programmable logic inputs, compatible with PLC level 1, standard IEC/EN 61131-2 24 V \pm internal power supply or 24 V \pm external power supply (min. 18 V, max. 30 V) Sampling time: < 20 ms Sampling time tolerance: ± 1 ms Factory-set with 2-wire control in "transition" mode for machine safety reasons: LI1: forward LI2 to LI4: not assigned Multiple assignment makes it possible to configure several functions on one input (for example: LI1 assigned to forward and preset speed 2, LI3 assigned to reverse and preset speed 3) Impedance 3.5 k Ω |
| | Positive logic (Source) | Factory setting State 0 if < 5 V, state 1 if > 11 V |
| | Negative logic (Sink) | Software-configurable State 0 if > 16 V or logic input not wired, state 1 if < 10 V |
| Logic output | LO+, LO- | One 24 V \pm logic output assignable as positive logic (Source) or negative logic (Sink) open collector type, compatible with level 1 PLC, standard IEC/EN 61131-2 Maximum voltage: 30 V Linearity: $\pm 1\%$ Maximum current: 10 mA (100 mA with external power supply) Impedance: 1 k Ω Update time: < 20 ms |
| Maximum I/O wire size and tightening torque | | 1.5 mm ² (14 AWG) 0.5 Nm |
| Acceleration and deceleration ramps | | Ramp profile: Linear from 0 to 999.9 s S ramp U ramp Automatic adaptation of deceleration ramp time if braking capacities exceeded, although this adaptation can be disabled (use of braking unit) |
| Emergency braking | | By DC injection: automatically as soon as the estimated output frequency drops to < 0.2 Hz, period adjustable from 0.1 to 30 s or continuous, current adjustable from 0 to 1.2 I _n |
| Main drive protection features | | Thermal protection against overheating Protection against short-circuits between motor phases Overcurrent protection between motor phases and ground Protection in the event of line overvoltage and undervoltage Input phase loss protection, in three-phase |
| Motor protection | | Thermal protection integrated in the drive by continuous calculation of the I ² t |
| Frequency resolution | | Display unit: 0.1 Hz Analog inputs: 10-bit A/D converter |
| Time constant on a change of setpoint | ms | 20 \pm 1 ms |

Communication port specifications

| | | |
|--------------------|------------------------------------------------------------|------------------------------------------------------------------------------------------------------------------------------------------------------------------------------------------------------------------------------------------|
| Protocol | | Modbus® |
| Structure | Connector | 1 RJ45 connector |
| | Physical interface | 2-wire RS 485 |
| | Transmission mode | RTU |
| | Transmission speed | Configurable via the Human/Machine interface, remote display terminal or SoMove setup software: 4800 bps, 9600 bps, 19200 bps or 38400 bps |
| | Number of subscribers | 31 maximum |
| | Polarization | No polarization impedance. This must be provided by the wiring system (for example, in the master) |
| | Address | 1 to 247, configurable via the Human/Machine interface, remote display terminal or SoMove setup software |
| Services | Profile | Based on IEC 61800-7-301 (CiA 402 profile) |
| | Messaging | Read Holding Registers (03) 29 words maximum Write Single Register (06) 29 words maximum Write Multiple Registers (16) 27 words maximum Read/Write Multiple Registers (23) 4/4 words maximum Read Device Identification (43) |
| | Communication monitoring | Can be inhibited. Time out can be set between 0.1 s and 30 s |
| Diagnostics | Via the Human/Machine interface or remote display terminal | On display unit |

Torque specifications (typical curves)

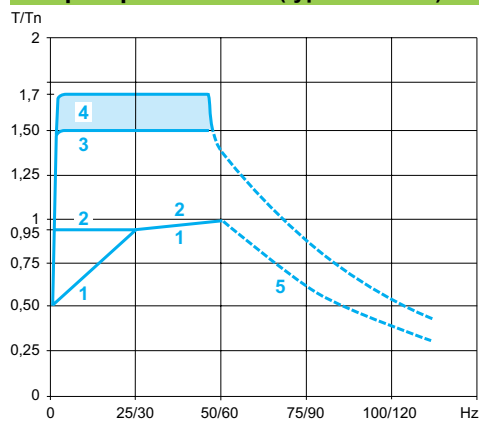

The curves opposite define the available continuous torque and transient overtorque for both self-cooled and force-cooled motors. The only difference is in the ability of the motor to provide a high continuous torque at less than half the nominal speed.

- 1 Self-cooled motor: continuous useful torque (1)
- 2 Force-cooled motor: continuous useful torque
- 3 Transient overtorque for 60 s
- 4 Transient overtorque for 2 s
- 5 Torque in overspeed at constant power (2)

(1) For power ratings ≤ 250 W, de-rating is 20% instead of 50% at very low frequencies.
(2) The nominal motor frequency and the maximum output frequency can be adjusted from 0.5 to 400 Hz. The mechanical overspeed capability of the selected motor must be checked with the manufacturer.

Special uses

Use with a motor with different power to the drive rating

The device can power any motor which has a lower rating than that for which the drive was designed, provided that the minimum current value is complied with: $I_{th} = 0.2 \times I_n$.
For motor ratings slightly higher than that of the drive, check that the current taken does not exceed the continuous output current of the drive.

Connecting motors in parallel

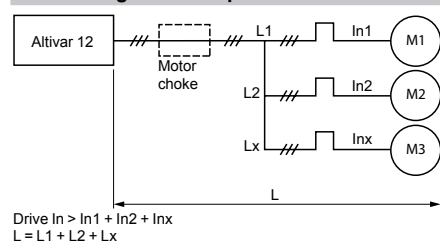

Connecting motors in parallel

The drive rating must be greater than or equal to the sum of the currents of the motors to be connected to the drive (I_n). In this case, it is necessary to provide external thermal protection for each motor using probes or thermal overload relays.

Use of a motor choke (1) is recommended in the following cases:
When three or more motors are connected in parallel
When the motor cable length (L), including all tap links (L1, L2 to Lx), is longer than the maximum permitted motor cable length (2)

- (1) See References on page 17.
- (2) For maximum permitted motor cable length, see page 11.

Motor switching at the drive output

Motor switching is possible with the drive unlocked. The integrated protection in Altivar® 12 drives offers better immunity to downstream breaking of the powered motor.

Altivar® 12

variable speed drives

Drives with heatsink, drives on a base plate



ATV12H018M2



ATV12H075M2



ATV12HU40M3



ATV12PU22M3



ATV12HU15M2TQ (8)

Drives with heatsink

| Motor Power indicated on rating plate (1) | Line supply | | | | Altivar 12 | | | Reference | Weight (2) |
|--------------------------------------------------------|-----------------------------|-------------------|-------|--------------------------------------|--------------------------------------------------------|---------------------------------------------|--------------------------------------------------------------------|-----------------|---------------|
| | Max. line current (3) | Apparent power | | Max. prospec- tive line Isc | Maximum continuous output current (In) (1) | Maximum transient current for 60 s | Dissipated power at maximum output current (In) (1) | | |
| | | at U1 | at U2 | | | | | | |
| kW HP | A | A | kVA | kA | A | A | W | kg | |
| Single-phase supply voltage: 100 to 120 V 50/60 Hz (4) | | | | | | | | | |
| 0.18 0.25 | 6 | 5 | 0.6 | 1 | 1.4 | 2.1 | 18 | ATV12H018F1 (5) | 0.700 |
| 0.37 0.5 | 11.4 | 9.3 | 1.1 | 1 | 2.4 | 3.6 | 29 | ATV12H037F1 | 0.800 |
| 0.75 1 | 18.9 | 15.7 | 1.9 | 1 | 4.2 | 6.3 | 48 | ATV12H075F1 | 1.300 |

Single-phase supply voltage: 200 to 240 V 50/60 Hz (4) (6)

| | | | | | | | | | |
|-----------|------|------|-----|---|-----|------|----|---------------------|-------|
| 0.18 0.25 | 3.4 | 2.8 | 0.7 | 1 | 1.4 | 2.1 | 18 | ATV12H018M2 (5) (7) | 0.700 |
| 0.37 0.55 | 5.9 | 4.9 | 1.2 | 1 | 2.4 | 3.6 | 27 | ATV12H037M2 (7) | 0.700 |
| 0.55 0.75 | 8 | 6.7 | 1.6 | 1 | 3.5 | 5.3 | 34 | ATV12H055M2 (7) | 0.800 |
| 0.75 1 | 10.2 | 8.5 | 2 | 1 | 4.2 | 6.3 | 44 | ATV12H075M2 (7) | 0.800 |
| 1.5 2 | 17.8 | 14.9 | 3.6 | 1 | 7.5 | 11.2 | 72 | ATV12HU15M2 (8) | 1.400 |
| 2.2 3 | 24 | 20.2 | 4.8 | 1 | 10 | 15 | 93 | ATV12HU22M2 (8) | 1.400 |

Three-phase supply voltage: 200 to 240 V 50/60 Hz (4)

| | | | | | | | | | |
|-----------|------|------|-----|---|------|------|-----|-----------------|-------|
| 0.18 0.25 | 2 | 1.7 | 0.7 | 5 | 1.4 | 2.1 | 16 | ATV12H018M3 (5) | 0.700 |
| 0.37 0.55 | 3.6 | 3 | 1.2 | 5 | 2.4 | 3.6 | 24 | ATV12H037M3 | 0.800 |
| 0.75 1 | 6.3 | 5.3 | 2.2 | 5 | 4.2 | 6.3 | 41 | ATV12H075M3 | 0.800 |
| 1.5 2 | 11.1 | 9.3 | 3.9 | 5 | 7.5 | 11.2 | 73 | ATV12HU15M3 | 1.200 |
| 2.2 3 | 14.9 | 12.5 | 5 | 5 | 10 | 15 | 85 | ATV12HU22M3 | 1.200 |
| 3 | 19 | 15.9 | 6.6 | 5 | 12.2 | 18.3 | 94 | ATV12HU30M3 | 2.000 |
| 4 5 | 23.8 | 19.9 | 8.3 | 5 | 16.7 | 25 | 128 | ATV12HU40M3 | 2.000 |

Drives on a base plate

Single-phase supply voltage: 100 to 120 V 50/60 Hz (4)

| | | | | | | | | | |
|-----------|---|------|-----|-----|-----|-----|----|-----------------|-------|
| 0.18 0.25 | 6 | 5 | 0.6 | 1 | 1.4 | 2.1 | 18 | ATV12H018F1 (5) | 0.700 |
| – | – | 11.4 | 9.3 | 1.1 | 1 | 2.4 | 29 | ATV12P037F1 (9) | 0.700 |

Single-phase supply voltage: 200 to 240 V 50/60 Hz (4) (6)

| | | | | | | | | | |
|-----------|-----|------|-----|-----|-----|-----|----|---------------------|-------|
| 0.18 0.25 | 3.4 | 2.8 | 0.7 | 1 | 1.4 | 2.1 | 18 | ATV12H018M2 (5) (7) | 0.700 |
| – | – | 5.9 | 4.9 | 1.2 | 1 | 2.4 | 27 | ATV12P037M2 (9) | 0.700 |
| – | – | 8 | 6.7 | 1.6 | 1 | 3.5 | 34 | ATV12P055M2 (9) | 0.700 |
| – | – | 10.2 | 8.5 | 2 | 1 | 4.2 | 44 | ATV12P075M2 (9) | 0.700 |

Three-phase supply voltage: 200 to 240 V 50/60 Hz (4)

| | | | | | | | | | |
|-----------|---|------|------|-----|-----|------|-----|-----------------|-------|
| 0.18 0.25 | 2 | 1.7 | 0.7 | 5 | 1.4 | 2.1 | 16 | ATV12H018M3 (5) | 0.700 |
| – | – | 3.6 | 3 | 1.2 | 5 | 2.4 | 24 | ATV12P037M3 (9) | 0.700 |
| – | – | 6.3 | 5.3 | 2.2 | 5 | 4.2 | 41 | ATV12P075M3 (9) | 0.700 |
| – | – | 11.1 | 9.3 | 3.9 | 5 | 7.5 | 73 | ATV12PU15M3 (9) | 1.000 |
| – | – | 14.9 | 12.5 | 5 | 5 | 10 | 85 | ATV12PU22M3 (9) | 1.000 |
| – | – | 19 | 15.9 | 6.6 | 5 | 12.2 | 94 | ATV12PU30M3 (9) | 1.600 |
| – | – | 23.8 | 19.9 | 8.3 | 5 | 16.7 | 128 | ATV12PU40M3 (9) | 1.600 |

(1) These values are given for a nominal switching frequency of 4 kHz, for use in continuous operation.

If operation above 4 kHz needs to be continuous, the nominal drive current should be derated by 10% for 8 kHz, 20% for 12 kHz and 30% for 16 kHz.

The switching frequency can be set between 2 and 16 kHz for all ratings.

Above 4 kHz, the drive will reduce the switching frequency automatically in the event of an excessive temperature rise.

See the de-rating curves in the User Manual, available on our website at "www.schneider-electric.us".

(2) Weight of product without packaging.

(3) Typical value for the indicated motor power and for the maximum prospective line Isc.

(4) Min. (U1) and max. (U2) nominal supply voltage: 100 (U1) to 120 V (U2), 200 (U1) to 240 V (U2).

(5) Due to the poor heat dissipation, the ATV12H018M2 drive is only supplied as a base plate version.

(6) Drive supplied with category C1 integrated EMC filter. This filter can be disconnected.

(7) Available in lots of 14: add **TQ** at the end of the reference. For example, ATV12H018M2 becomes **ATV12H018M2TQ**.

(8) Available in lots of 7: add **TQ** at the end of the reference. ATV12HU22M2 becomes **ATV12HU22M2TQ**.

(9) To size the ATV12P drive correctly, see the specific manual for the Altivar®12 base plate version, available on our website at "www.schneider-electric.us".



VW3A9804



VW3A9523



VW3A9524



VW3A8114



Configuring the drive in its packaging with the Multi-Loader tool VW3A8121 + cordset VW3A8126

Accessories

| Description | For drives | Reference | Weight kg |
|------------------------------------------------------------------------------------------------------------------------------------------------------------------------------|----------------------------------------------------------------------------------------------------------------------------------------|-------------------|-----------|
| Mounting plates for mounting on 35 mm wide DIN rail | ATV12H018F1, H037F1 ATV12H018M2 to H075M2 ATV12H018M3 to H075M3 | VW3A9804 | 0.290 |
| | ATV12H075F1 ATV12HU15M2, HU22M2 ATV12HU15M3, HU22M3 | VW3A9805 | 0.385 |
| EMC conformity kits These provide a connection compliant with EMC standards (see page 23) The kit consists of: The EMC plate Clamps Fixing accessories | ATV12H018F1, H037F1 ATV12H018M2 to H075M2 ATV12H018M3 to H075M3 ATV12P037F1 ATV12P037M2 to P075M2 ATV12P037M3 to P075M3 | VW3A9523 | 0.170 |
| | ATV12H075F1 ATV12HU15M2, HU22M2 ATV12HU15M3, HU22M3 ATV12PU15M3, PU22M3 | VW3A9524 | 0.190 |
| | ATV12HU30M3, HU40M3 ATV12PU30M3, PU40M3 | VW3 A9 525 | 0.210 |
| +15 V/+24 V voltage converter Connects directly to the control terminals | ATV12●●●●●● | VW3A9317 | – |

Configuration tools

| Description | For drives | Reference | Weight kg |
|--------------------------------------------------------------------------------------------------------------------------------------------------------------------------------------------------------------------------------------------------------------------------------------------------------------------------------------------------------------------------------------------------------------|------------------------------|-----------------------|-----------|
| SoMove™ lite setup software and associated accessories | | | |
| SoMove lite setup software For configuring, adjusting and debugging the Altivar 12 drive. Downloadable from our website "www.schneider-electric.us" or available on the "Description of the Motion & Drives Offer" DVD ROM VW3A8200 . | ATV12●●●●●● | – | – |
| USB/RJ45 cable equipped with a USB connector and an RJ45 connector. For connecting a PC to the Altivar 12 drive. Length: 2.5 m | ATV12●●●●●● | TCSMCNAM3M002P | – |
| Modbus - Bluetooth adaptor For establishing a Bluetooth wireless connection between the Altivar 12 drive and a PC equipped with a Bluetooth wireless link. Pack contents: 1 Bluetooth adaptor (range 10 m, class 2) with an RJ45 connector 1 x 0.1 m cordset with 2 RJ 45 connectors (1) | ATV12●●●●●● | VW3A8 114 | 0.155 |
| USB - Bluetooth adaptor for PC Required for a PC which is not equipped with Bluetooth technology. Connects to a USB port on the PC. Range of 10 m (class 2). | – | VW3A8 115 | 0.200 |
| Simple Loader, Multi-Loader configuration tools and associated cable | | | |
| Simple Loader tool For duplicating one drive configuration on another drive. The drives must be powered-up. The tool is supplied with a cordset equipped with 2 RJ45 connectors. | ATV12●●●●●● | VW3A8 120 | – |
| Multi-Loader tool 1 For copying a configuration on a PC or drive and duplicating it on another drive. The drives do not need to be powered-up. Supplied with the tool: 1 cordset equipped with 2 RJ45 connectors 1 cordset equipped with a USB type A connector and a USB Mini-B type connector 1 x 2 GB SD memory card 1 female/female RJ45 adaptor 4 AA/LR6 1.5 V batteries | ATV12●●●●●● | VW3A8 121 | – |
| Cordset for Multi-Loader tool 2 For connecting the Multi-Loader tool to the Altivar 12 drive in its packaging. Equipped with a non-locking RJ45 connector with special mechanical catch on the drive end and an RJ45 connector on the Multi-Loader end. | ATV12●●●●●● in its packaging | VW3A8 126 | – |

(1) Also includes other components for connecting compatible Schneider Electric devices.

Altivar® 12 variable speed drives

Configuration tools, remote display terminals,
braking unit and resistors, additional EMC filters



VW3A1006 with cover open:
RUN, FWD/REV and STOP
buttons accessible



VW3A7701



VW3A4416



ATV12H075M2 with EMC kit
VW3A9523 mounted on EMC
filter VW3A4416

Configuration tools (continued)

| Description | For drives | Reference | Weight kg |
|----------------------------------------------------------------------------------------------------------------------------------------------------------------------------------------------------------------------------------------------------------------------------------------------------------------------------------------------------------------------------------|-------------|-----------|--------------|
| SoMove Mobile software for mobile phone (1) | | | |
| SoMove Mobile software allows you to edit drive parameters from a mobile phone using a Bluetooth® wireless connection. Requires the Modbus® - Bluetooth adaptor VW3A8114 (see page 15). It can also be used to back up configurations, which can be imported or exported from a PC. SoMove Mobile software can be downloaded from our website "www.schneider-electric.us". | ATV12●●●●●● | - | - |

Remote display terminals and associated cordsets

| Description | Ohmic value at 20°C | Average power available at 40°C | For drives | Reference | Weight kg |
|-------------------------------------------------------------------------------------------------------------------------------------------------------------------------------------------------------|----------------------------|---------------------------------|-------------|-----------|--------------|
| Remote display terminals For mounting the Human/Machine Interface on an enclosure door with IP 54 or IP 65 degree of protection. A remote-mounting cordset VW3A1104R●● is also required. | IP 54 degree of protection | ATV12●●●●●● | VW3A1006 | 0.250 | |
| | IP 65 degree of protection | ATV12●●●●●● | VW3A1007 | 0.275 | |
| Remote-mounting cordsets equipped with 2 RJ45 connectors. For connecting the VW3A1006 or VW3A1007 remote display terminal to the Altivar™ 12 drive. | Length: 1 m | ATV12●●●●●● | VW3A1104R10 | 0.050 | |
| | Length: 3 m | ATV12●●●●●● | VW3A1104R30 | 0.150 | |

Braking unit and resistors

| Description | Ohmic value at 20°C | Average power available at 40°C | For drives | Reference | Weight kg |
|------------------------------------------------------------------------------------------------------------------------------------------------------------------------------------|---------------------|---------------------------------|-------------------------------------------------------------------------------------------------------------------------------------|-----------|--------------|
| Resistance braking unit To be connected to the DC bus. Needs at least one braking resistor. For mounting on a 35 mm AM1 ED DIN rail, to be ordered separately (2). | - | - | ATV12●●●●F1 ATV12●●●●M2 ATV12H018M3 to HU22M3 ATV12P037M3 to PU22M3 | VW3A7005 | 0.285 |
| Braking resistors Protected (IP 20) If a resistor other than those specified is being used, add a thermal protection device. | 100 | 58 | ATV12●●●●F1 (3) ATV12H018M2 to HU15M2 (3) ATV12H018M3 to HU15M3 (3) ATV12P037M2 to P075M2 (3) ATV12P037M3 to PU15M3 (3) | VW3A7701 | 1.580 |
| | 60 | 115 | ATV12HU22M2 (4) ATV12HU22M3 (4) ATV12PU22M3 (4) | VW3A7702 | 1.660 |
| Braking resistors Unprotected (IP 00) If a resistor other than those specified is being used, add a thermal protection device. | 100 | 32 | ATV12●●●●F1 (3) ATV12H018M2 to HU15M2 (3) ATV12H018M3 to HU15M3 (3) ATV12P037M2 to P075M2 (3) ATV12P037M3 to PU15M3 (3) | VW3A7723 | 0.605 |
| | 68 | 32 | ATV12HU22M2 (4) ATV12HU22M3 (4) ATV12PU22M3 (4) | VW3A7724 | 0.620 |

Additional EMC input filters

| Description | For drives | Reference | Weight kg |
|----------------------------------------------------------------------------------------------------------------------------------------------------------------------------------------------------------------------------------------------------------------------------------------------------------------------------------------------------------------------------------------------------------------------------------------------------------------|----------------------------------------------------------------------------------------|-----------|--------------|
| Additional EMC input filters For compliance with the requirements of standard IEC/EN 61800-3, category C1, C2 or C3, in Environment 1 (public network) or 2 (industrial network), depending on the drive rating. See the "Conducted EMC emissions" and "Radiated EMC emissions" specifications on page 10 to check the permitted shielded motor cable lengths depending on the category and the environment according to standard IEC/EN 61800-3. | ATV12H018F1 to H037F1 ATV12H018M2 to H075M2 ATV12P037F1 ATV12P037M2 to P075M2 | VW3A4416 | 1.120 |
| | ATV12H075F1 ATV12HU15M2, HU22M2 | VW3A4417 | 1.455 |
| | ATV12H018M3 to H075M3 ATV12P037M3 to P075M3 | VW3A4418 | 1.210 |
| | ATV12HU15M3, HU22M3 ATV12PU15M3, PU22M3 | VW3A4419 | 1.440 |

(1) The SoMove Mobile software requires a basic mobile phone; please consult our website "www.schneider-electric.us".

(2) Please consult our website "www.schneider-electric.us".

(3) Minimum value of the resistor to be used: 75 ohms.

(4) Minimum value of the resistor to be used: 51 ohms.

Altivar® 12 variable speed drives

Motor chokes, Modbus® serial link,
documentation, replacement parts

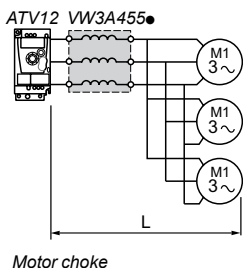

Motor chokes

| Description | Nominal current A | For drives | Reference | Weight kg |
|------------------------------------------------------------------------------------------------------------------------------------------------------------------------------------------------------------------------------------------------------------------|----------------------|--------------------------------------------------------------------------------------------------------------------------|-----------------|--------------|
| Motor chokes Required: When connecting more than 2 motors in parallel When the motor cable length (L), including tap-offs, is: □ 50 to 100 m for a shielded motor cable (1), □ 100 to 200 m for an unshielded motor cable (1). | 4 | ATV12H018F1, H037F1 ATV12H018M2 to H055M2 ATV12H018M3, H037M3 ATV12P037F1 ATV12P037M2, P055M2 ATV12P037M3 | VW3A4551 | 1.880 |
| | 10 | ATV12H075F1 ATV12H075M2, HU15M2 ATV12H075M3, HU15M3 ATV12P075M2 ATV12P075M3, PU15M3 | VW3A4552 | 3.700 |
| | 16 | ATV12HU22M2 ATV12HU22M3, HU30M3 ATV12PU22M3, PU30M3 | VW3A4553 | 4.100 |
| | 30 | ATV12HU40M3 ATV12PU40M3 | VW3A4554 | 6.150 |

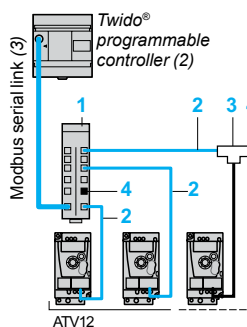

Example of Modbus diagram
with connection via splitter box
and RJ45 connectors

Modbus® serial link

| Description | Item no. | Length m | Unit reference | Weight kg |
|---------------------------------------------------------------------------|----------|-------------|---------------------|--------------|
| Connection via splitter box and RJ45 connectors | | | | |
| Modbus splitter box 10 RJ45 connectors and 1 screw terminal | 1 | – | LU9GC3 | 0.500 |
| Cordsets for Modbus serial link equipped with 2 RJ45 connectors | 2 | 0.3 | VW3A8306R03 | 0.025 |
| | | 1 | VW3A8306R10 | 0.060 |
| | | 3 | VW3A8306R30 | 0.130 |
| Modbus T-junction boxes (with integrated cable) | 3 | 0.3 | VW3A8306TF03 | 0.190 |
| | | 1 | VW3A8306TF10 | 0.210 |
| Line terminators (4) (5) For RJ45 connector | 4 | – | VW3A8306RC | 0.010 |
| | 4 | – | VW3A8306R | 0.010 |

Documentation

| Description | For drives | Reference | Weight kg |
|---------------------------------------------------------------------------------------------------------------------------------------------------------------------------------------------------------------------------------------|-------------|-----------------|--------------|
| "Description of the Motion & Drives Offer" DVD ROM Contents (6): Technical documentation (programming manuals, installation manuals, quick reference guides) SoMove lite setup software, catalogs Brochures | ATV12●●●●●● | VW3A8200 | 0.100 |



VZ3V1302

Replacement parts

| Description | For drives | Reference | Weight kg |
|-------------|-----------------------|-----------------|--------------|
| Fans | ATV12H075F1 | VZ3V1301 | 0.160 |
| | ATV12HU15M2, HU22M2 | | |
| | ATV12HU15M3 to HU40M3 | VZ3V1302 | 0.150 |

(1) Motor cable length given for a switching frequency of 4 kHz.

(2) Please refer to the Twido programmable controller catalog.

(3) Cable depends on the type of controller or PLC.

(4) Order in multiples of 2.

(5) Depends on the bus architecture.

(6) The content of this DVD ROM is also available on our website at "www.schneider-electric.us".

Drives with heatsinks (1)

ATV12H018F1, H037F1, ATV12H018M2 to H075M2, ATV12H018M3 to H075M3

Drive with EMC conformity kit VW3A9523 (available as an option)

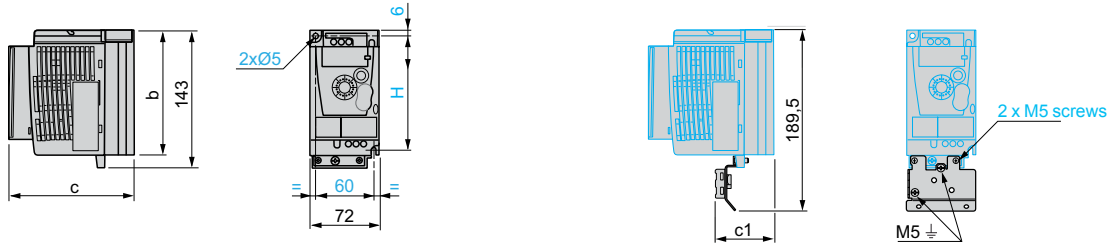

| ATV12 | b | c | c1 | H |
|------------------------------------|-----|-------|----|-----|
| H018F1 (1), H018M2 (1), H018M3 (1) | 142 | 102.2 | 34 | 131 |
| H037F1, H037M2, H037M3 | 130 | 121.2 | 53 | 120 |
| H055M2, H075M2, H075M3 | 130 | 131.2 | 63 | 120 |

(1) Due to the poor heat dissipation, ATV12H018●● drives are only available as a base plate version. They can either be mounted conventionally (drive on heatsink) or on the machine frame (drive on base plate).

ATV12H075F1, ATV12HU15M2, HU22M2, ATV12HU15M3, HU22M3

Drive with EMC conformity kit VW3A9524 (available as an option)

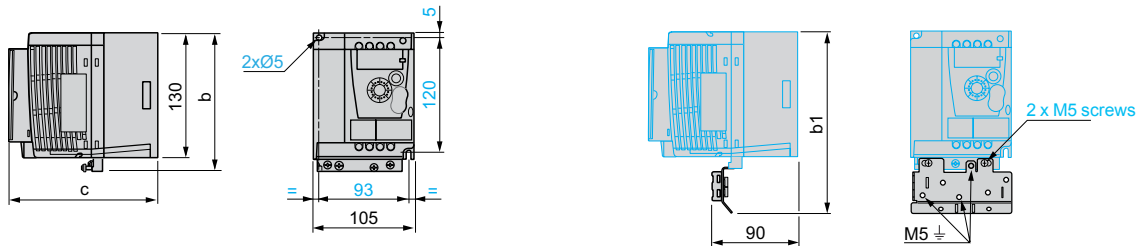

| ATV12 | b | b1 | c |
|------------------------|-----|-------|-------|
| H075F1, HU15M2, HU22M2 | 142 | 188.2 | 156.2 |
| HU15M3, HU22M3 | 143 | 189.3 | 131.2 |

ATV12HU30M3, HU40M3

Drive with EMC conformity kit VW3A9525 (available as an option)

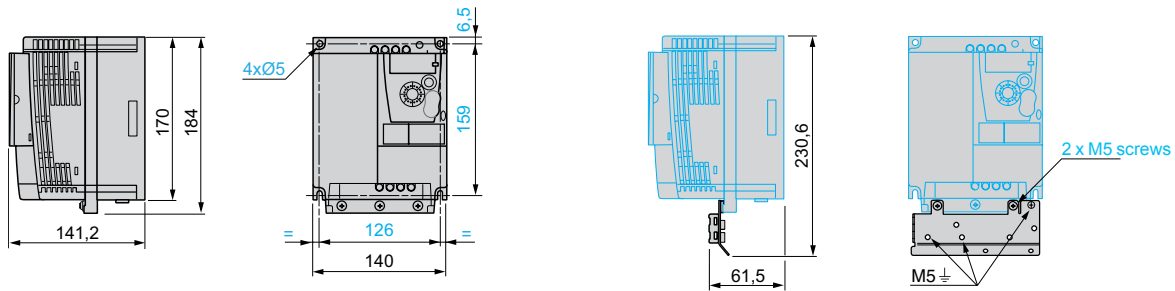

Drives on a base plate

ATV12P037F1, ATV12P037M2 to P075M2, ATV12P037M3 to P075M3

Drive with EMC conformity kit VW3A9523 (available as an option)

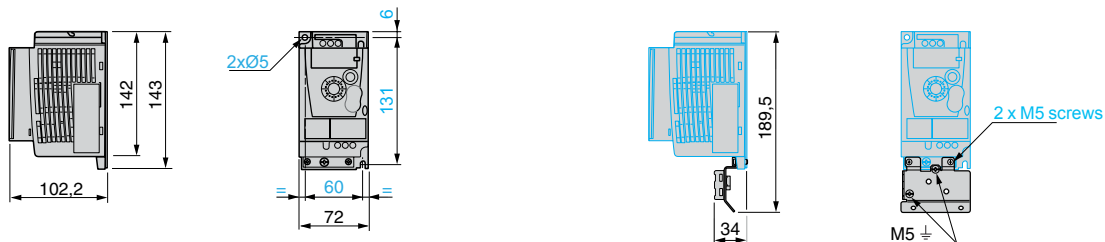

ATV12PU15M3, PU22M3

Drive with EMC conformity kit VW3A9524 (available as an option)

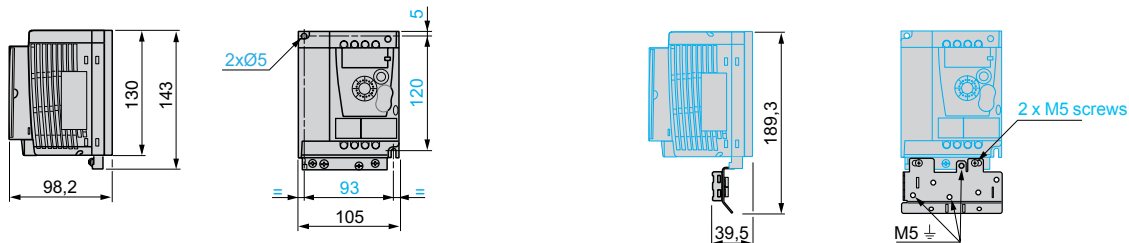

ATV12PU30M3, PU40M3

Drive with EMC conformity kit VW3A9525 (available as an option)

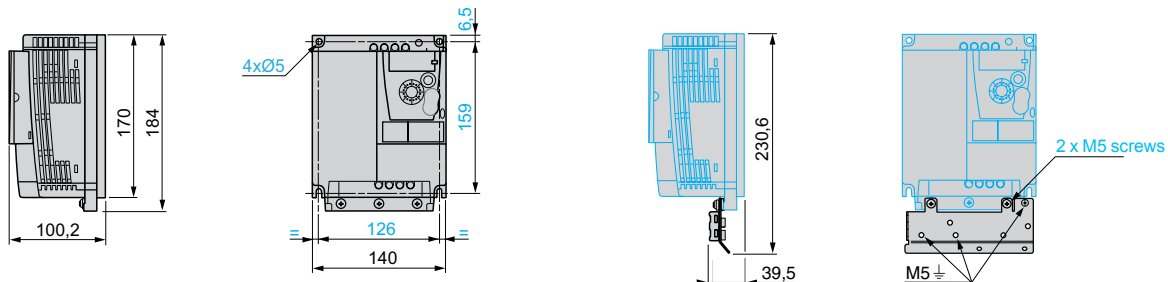

Recommendations for mounting on the machine frame (specific to ATV12P●●●● drives)

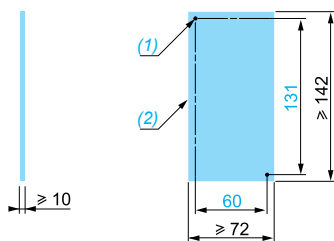

Example of cooling area for ATV12P037M2

- (1) 2 x Ø M4 tapped holes
- (2) Minimum machined area

Note: The general rules set out below should be adapted to suit the operating environment. Please refer to the specific manual for the Altivar® 12 base plate version, available on our website at "www.schneider-electric.us".

ATV12P●●●● drives can be mounted on (or in) a steel or aluminium machine frame, observing the following conditions:

Maximum ambient temperature: 40°C

Vertical mounting at ± 10°

The drive must be mounted at the center of a support (frame) with high thermal conductivity

Support area for the drive machined on the frame with a surface smoothness of 100 µm max and unevenness of 3.2 µm max.

When the operating conditions are close to the maximum limits (power, cycle and temperature) this type of use must be checked beforehand, by monitoring the thermal state of the drive.

Altivar® 12 variable speed drives

Accessories, remote display terminal, braking unit and resistors, motor chokes, EMC filters

Accessories

Mounting plates for mounting on an AM1 ED 35 mm DIN rail

VW3A9804

VW3A9805

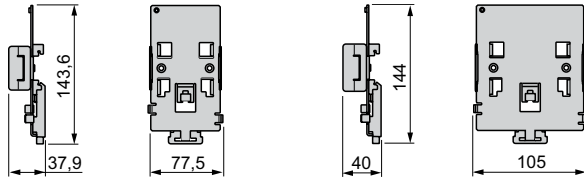

Options

Remote display terminal

VW3A1006

Braking unit

VW3A7005

(mounting on 35 mm AM1 ED DIN rail)

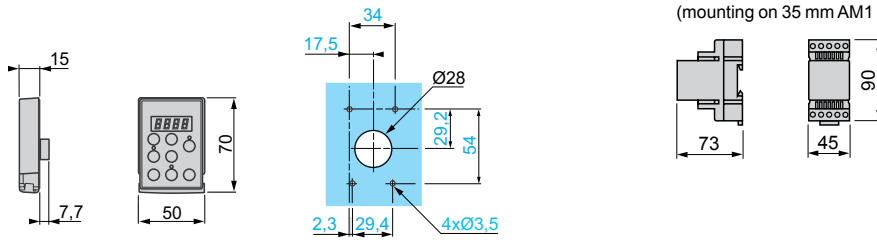

Braking resistors

VW3A7701, 702

VW3A7 723, 724

(2 flying leads 0.5 m long)

Mounting recommendations

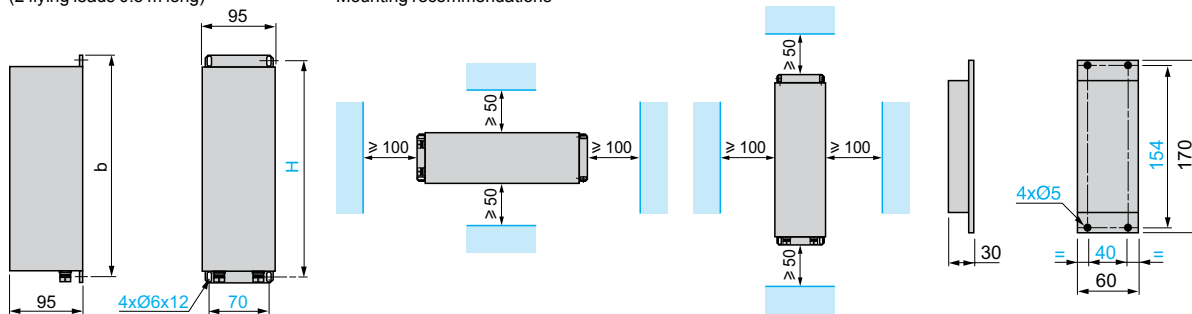

| VW3 | b | H |
|-------|-----|-----|
| A7701 | 295 | 275 |
| A7702 | 395 | 375 |

Motor chokes

VW3A4551 to 554

Additional EMC input filters

VW3A4416 to 419

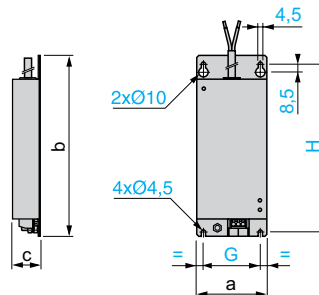
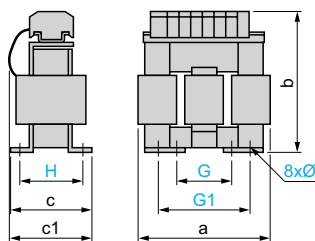

| VW3 | a | b | c | c1 | G | G1 | H | Ø |
|--------------|-----|-----|-----|-----|----|------|----|--------|
| A4551 | 100 | 135 | 55 | 60 | 40 | 60 | 42 | 6 x 9 |
| A4552, A4553 | 130 | 155 | 85 | 90 | 60 | 80.5 | 62 | 6 x 12 |
| A4554 | 155 | 170 | 115 | 135 | 75 | 107 | 90 | 6 x 12 |

| VW3 | a | b | c | G | H |
|--------|-----|-----|----|----|-----|
| A4416 | 75 | 194 | 30 | 61 | 180 |
| A4417 | 117 | 184 | 40 | 97 | 170 |
| A418 | 75 | 194 | 40 | 61 | 180 |
| A4 419 | 117 | 190 | 40 | 97 | 170 |

Mounting recommendations

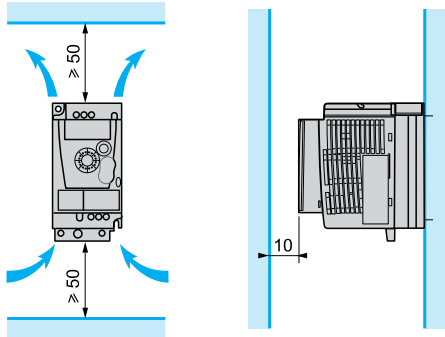

Install the unit vertically, at $\pm 10^\circ$.
 Avoid placing it close to heating elements.
 Leave sufficient free space to ensure that the air required for cooling purposes can circulate, by natural convection or by ventilation, from the bottom to the top of the unit.

Operating temperature according to the mounting type

Mounting type

Drives with natural convection

ATV12H018F1, H037F1
 ATV12H018M2 to H075M2
 ATV12H018M3 to H075M3

Drives with fan

ATV12H075F1
 ATV12HU15M2, HU22M2
 ATV12HU15M3 to HU40M3

Ambient air temperature (1)

Ambient air temperature (1)

Type A mounting

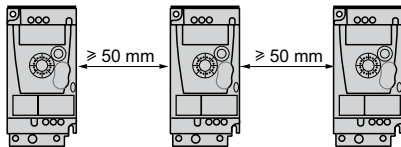

-10 to +40°C
 Up to +50°C with current de-rating of 2% per additional degree above 40°C

-10 to +50°C

Type B mounting (2)

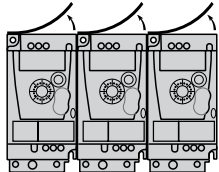

-10 to +40°C (3)
 Up to +60°C with current de-rating of 2% per additional degree above 40°C

-10 to +50°C
 Up to +60°C with current de-rating of 2% per additional degree above 50°C

Type C mounting (2)

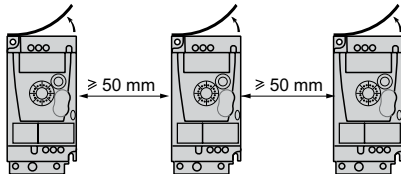

-10 to +40°C
 Up to +60°C with current de-rating of 2% per additional degree above 40°C
 -10 to +50°C on metal plate

-10 to +50°C
 Up to +60°C with current de-rating of 2% per additional degree above 50°C

(1) Value given for a switching frequency of 4 kHz, for use in continuous operation. If operation above 4 kHz needs to be continuous, the nominal drive current should be derated by 10% for 8 kHz, 20% for 12 kHz and 30% for 16 kHz.

Above 4 kHz, the drive will reduce the switching frequency automatically in the event of an excessive temperature rise.

See the de-rating curves in the User Manual, available on our website at "www.schneider-electric.us".

(2) Remove the protective cover from the top of the drive.

(3) Maximum value depending on the drive rating and operating conditions; see the de-rating curves in the User Manual, available on our website at "www.schneider-electric.us".

Recommended connections

Typical connection for ATV12●●●●F1, ATV12●●●●M2
Single-phase power supply

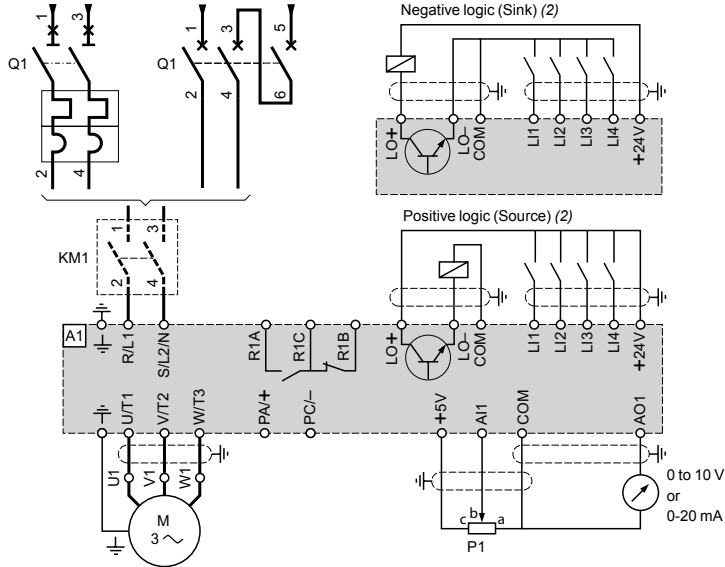

Typical connection for ATV12●●●●M3
Three-phase power supply (power section) (1)

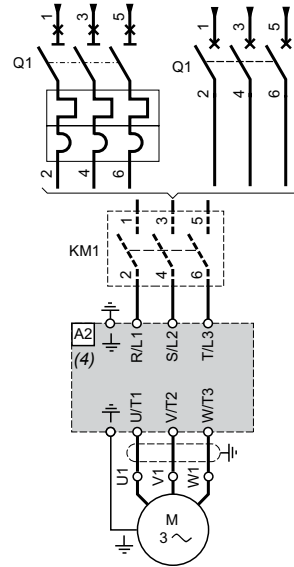

Note: Install interference suppressors on all inductive circuits near the drive or connected on the same circuit, such as relays, contactors, solenoid valves, fluorescent lighting, etc.

Compatible components (for a complete list of references, please refer to the "Motor starter solutions - Control and protection components" and "Motor starters up to 150 A" catalogs or visit "www.schneider-electric.us")

| Item no. | Description |
|----------|------------------------------------------------------------------------------------------------------|
| A1 | ATV12●●●●F1 or ATV12●●●●M2 drive (see page 14) |
| A2 | ATV12●●●●M3 drive (see page 14) |
| KM1 | Contact (only if a control circuit is needed; see page 24) |
| P1 | 2.2 kΩ reference potentiometer, SZ1 RV1202. This can be replaced by a 10 kΩ potentiometer (maximum). |
| Q1 | Circuit breaker (see page 24) |

Examples of recommended connections for logic and analog I/O

2-wire control

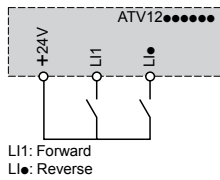

3-wire control

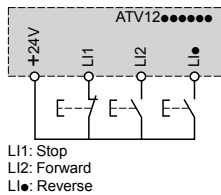

Analog input configured for voltage

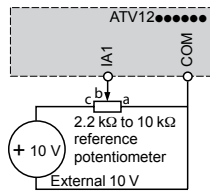

Analog input configured for current

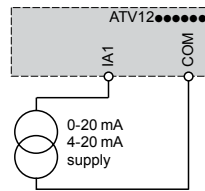

Examples of recommended connections for logic I/O powered by an external 24 V AC supply (5)

Connected as positive logic (Source)

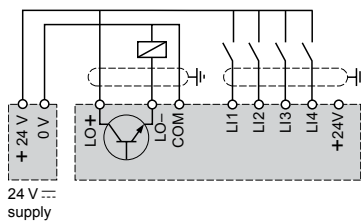

Connected as negative logic (Sink)

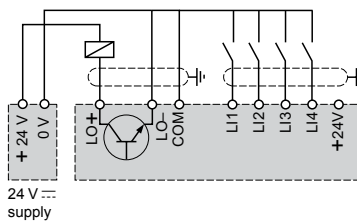

- (1) The control section is connected in exactly the same way as for the ATV12●●●●F1 and ATV12●●●●M2 drives.
- (2) Connection as positive logic (Source) or negative logic (Sink) is configured via parameters; the factory-set configuration is positive logic (Source).
- (3) Fault relay contacts for remote signalling of the drive status.
- (4) The R/L1, S/L2/N and T/L3 terminals are connected at the top of the drive. The other terminals are connected on the underside of the drive.
- (5) Please refer to the "Phaseo power supplies and transformers" catalog.

Recommended connections (continued)

Braking unit VW3A7005 used with braking resistors VW3A7701, 702, 723, 724

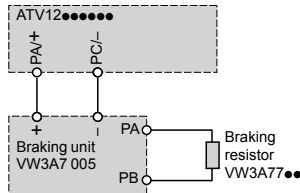

Motor chokes VW3A4551 to 554

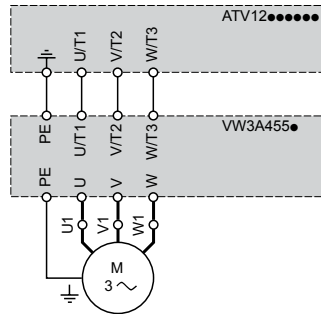

Additional EMC input filters VW3A4416 to 419

Single-phase power supply

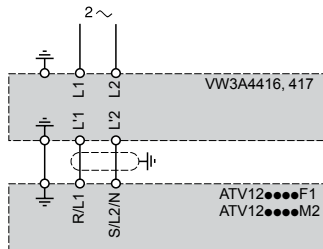

Three-phase power supply

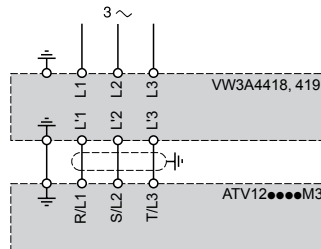

Connections for ensuring conformity to EMC standards

Principle

- Grounds between the drive, motor and cable shielding must have "high frequency" equipotentiality.
- Use shielded cables with shielding connected to ground throughout 360° at both ends for the motor cable and the control-signalling cables. Conduit or metal ducting can be used for part of the shielding length provided that there is no break in the continuity of the ground connection.
- Ensure maximum separation between the line supply cable and the motor cable.

Installation diagram

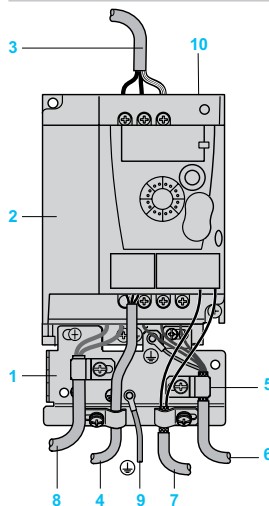

- 1 Metal plate to be mounted on the drive (grounded casing).
- 2 ATV12 drives
- 3 Unshielded power supply wires or cable
- 4 Unshielded wires or cable for the output of the fault relay contacts
- 5 Shielding of cables 6 and 7 attached and grounded as close as possible to the drive:
 - Strip the cable to expose the shielding.
 - Attach the cable to the plate 1 by tightening the clamp on the stripped part of the shielding.
 The shielding must be clamped tightly enough to the metal surface to ensure good contact.
For cables 6 and 7, the shielding must be connected to ground at both ends. The shielding must be continuous, and if intermediate terminals are used, they must be placed in EMC shielded metal boxes.
- 6 Shielded cable for connecting the motor
- 7 Shielded cable for connecting the control-signalling cables. For applications requiring several conductors, use cables with a small cross-section (0.5 mm²)
- 8 Unshielded cable for connecting the braking unit
- 9 PE cable (green-yellow)
- 10 Selector switch for disconnecting the integrated EMC filter on ATV12 M2 drives

Note: The HF equipotential ground connection between the drive, motor and cable shielding does not remove the need to connect the PE conductors (green-yellow) to the appropriate terminals on each unit. If using an additional EMC input filter, it should be mounted beneath the drive and connected directly to the line supply via an unshielded cable. Link 3 on the drive is then established via the filter output cable.

Use on an IT system (isolated or impedance grounded neutral)

Use a permanent insulation monitor, such as Schneider Electric's XM200, which is compatible with non-linear loads. ATV12 M2 drives have integrated EMC filters.

For use on an IT system, these filters can easily be disconnected by means of a selector switch 10 which can be accessed without removing the drive.

Altivar® 12 variable speed drives

Motor starters: Single-phase supply voltages 100 to 120 V and 200 to 240 V

Applications

The proposed combinations can:

- Protect people and equipment (when a short-circuit occurs)
- Maintain protection upstream of the drive in the event of a short-circuit on the power stage

Two types of combination are possible:

- Drive + circuit-breaker: Minimum combination
- Drive + circuit-breaker + contactor: Minimum combination with contactor when a control circuit is needed

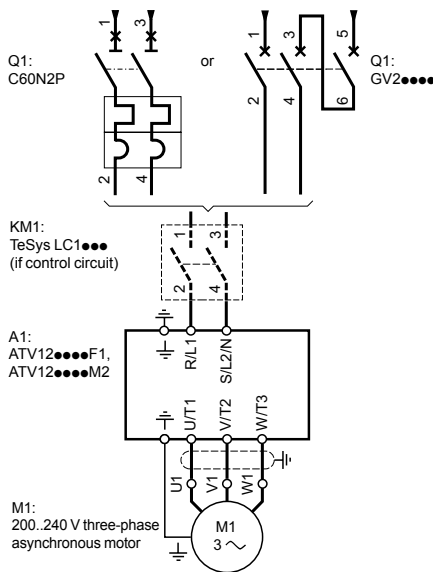

Motor starter with single-phase power supply

Motor starters

| Standard power ratings of three-phase 4-pole 50/60 Hz motors (2) | Variable speed drive | Combination with control circuit (circuit-breaker + contactor) | | | TeSys contactor (1) | |
|------------------------------------------------------------------|----------------------|----------------------------------------------------------------|---------------------------|----------|-----------------------------------|--------|
| | | Minimum combination (circuit-breaker only) | | | | |
| kW | HP | TeSys® motor circuit-breaker (3) | Operating range or rating | | Maximum short-circuit current Icu | |
| | | Modular circuit-breaker (4) | | | | |
| | | | A | kA | | |
| M1 | A1 | Q1 | | | KM1 | |
| Single-phase supply voltage: 100 to 120 V 50/60 Hz (5) | | | | | | |
| 0.18 | 0.25 | ATV12H018F1 | GV2ME14 | 6 to 10 | > 100 | LC1K09 |
| | | | GV2L10 | 6.3 | > 100 | |
| | | | 2-pole C60N | | 10 | 10 |
| 0.37 | 0.5 | ATV12●037F1 | GV2ME16 | 9 to 14 | > 100 | LC1K12 |
| | | | GV2L16 | 14 | > 100 | |
| | | | 2-pole C60N | | 16 | 10 |
| 0.75 | 1 | ATV12H075F1 | GV2ME21 | 17 to 23 | 50 | LC1D25 |
| | | | GV2L22 | 25 | > 50 | |
| | | | 2-pole C60N | | 20 | 10 |
| Single-phase supply voltage: 200 to 240 V 50/60 Hz (5) | | | | | | |
| 0.18 | 0.25 | ATV12H018M2 | GV2ME08 | 2.5 to 4 | > 100 | LC1K09 |
| | | | GV2L08 | 4 | > 100 | |
| | | | 2-pole C60N | | 6 | 10 |
| 0.37 | 0.55 | ATV12●037M2 | GV2ME14 | 6 to 10 | > 100 | LC1K09 |
| | | | GV2L10 | 6.3 | > 100 | |
| | | | 2-pole C60N | | 10 | 10 |
| 0.55 | 0.75 | ATV12●055M2 | GV2ME14 | 6 to 10 | > 100 | LC1K09 |
| | | | GV2L14 | 10 | > 100 | |
| | | | 2-pole C60N | | 10 | 10 |
| 0.75 | 1 | ATV12●075M2 | GV2ME16 | 9 to 14 | > 100 | LC1K12 |
| | | | GV L16 | 14 | > 100 | |
| | | | 2-pole C60N | | 16 | 10 |
| 1.5 | 2 | ATV12HU15M2 | GV2ME21 | 17 to 23 | 50 | LC1D18 |
| | | | GV2L20 | 18 | > 100 | |
| | | | 2-pole C60N | | 20 | 10 |
| 2.2 | 3 | ATV12HU22M2 | GV2ME32 | 24 to 32 | 50 | LC1D25 |
| | | | GV2L22 | 25 | 50 | |
| | | | 2-pole C60N | | 32 | 10 |

(1) For a complete list of references for TeSys contactors, please refer to the "Motor starter solutions - Control and protection components" and "Motor starters up to 150 A" catalogs or visit "www.schneider-electric.us".

(2) Motor power indicated for combination with an ATV12H●●●●● drive with the same rating. For combination with an ATV12P●●●●● drive, refer to the specific manual for the Altivar® 12 base plate version, available on our website at "www.schneider-electric.us".

(3) TeSys motor circuit-breakers:

- GV2ME●●: Thermal magnetic motor circuit-breakers with pushbutton control
- GV2L●●: Magnetic motor circuit-breakers with control by rotary knob

(4) 2-pole C60N modular circuit-breaker

(5) Can be integrated in devices connected to a power socket:

- If the line current is ≤ 16 A, connection to a single-phase power socket, 10/16 A 250 V ~

- If the line current is > 16 A, connection to a single-phase power socket conforming to standard IEC 60309

Altivar® 12 variable speed drives

Motor starters: Three-phase supply voltage
200 to 240 V

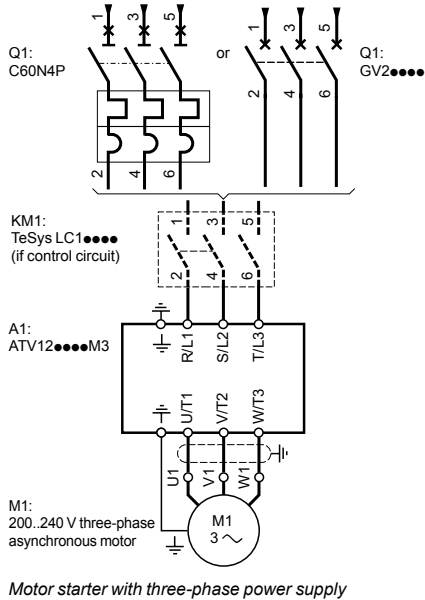

Motor starters (continued)

| Standard power ratings of three-phase 4-pole 50/60 Hz motors (2) | Variable speed drive | Combination with control circuit (circuit-breaker + contactor) | | | TeSys contactor (1) |
|------------------------------------------------------------------|----------------------|----------------------------------------------------------------|-------------|----------------------------------|---------------------|
| | | Minimum configuration (circuit-breaker only) | | | |
| kW | HP | A | kA | TeSys® motor circuit-breaker (3) | KM1 |
| | | | | Operating range or rating | |
| | | Modular circuit-breaker (4) | | | |
| M1 | A1 | Q1 | | | |
| Three-phase supply voltage: 200 to 240 V 50/60 Hz | | | | | |
| 0.18 | 0.25 | ATV12H018M3 | GV2ME07 | 1.6 to 2.5 > 100 | LC1K09 |
| | | | GV2L07 | 2.5 > 100 | |
| | | | 4-pole C60N | 6 10 | |
| 0.37 | 0.55 | ATV120037M3 | GV2ME08 | 2.5 to 4 > 100 | LC1K09 |
| | | | GV2L08 | 4 > 100 | |
| | | | 4-pole C60N | 6 10 | |
| 0.75 | 1 | ATV120075M3 | GV2ME14 | 6 to 10 > 100 | LC1K09 |
| | | | GV2L14 | 10 > 100 | |
| | | | 4-pole C60N | 10 10 | |
| 1.5 | 2 | ATV120U15M3 | GV2ME16 | 9 to 14 > 100 | LC1K12 |
| | | | GV2L16 | 14 > 100 | |
| | | | 4-pole C60N | 16 10 | |
| 2.2 | 3 | ATV120U22M3 | GV2ME20 | 13 to 18 > 100 | LC1D18 |
| | | | GV2L20 | 18 > 100 | |
| | | | 4-pole C60N | 20 10 | |
| 3 | - | ATV120U30M3 | GV2ME21 | 17 to 23 50 | LC1D25 |
| | | | GV2L22 | 25 50 | |
| | | | 4-pole C60N | 20 10 | |
| 4 | 5 | ATV120U40M3 | GV2ME32 | 24 to 32 50 | LC1D25 |
| | | | GV2L22 | 25 50 | |
| | | | 4-pole C60N | 32 10 | |

Combinations of C60N circuit-breakers/Vigi C60 add-on modules

| C60N | Vigi C60 | | |
|---------------|------------|----------|-------------|
| 2-pole/4-pole | | | |
| Rating (A) | Rating (A) | Type (5) | Sensitivity |
| 6 | 25 | A "si" | 30 mA |
| 10 | 25 | A "si" | 30 mA |
| 16 | 25 | A "si" | 30 mA |
| 20 | 25 | A "si" | 30 mA |
| 32 | 40 | A "si" | 30 mA |

Recommendations for special uses:

All RH10/RH21/RH99/RHU residual current protection devices with separate sensors are compatible as long as the type and sensitivity of the add-on modules given in the table above are observed.

It is advisable to connect one RCD (residual current device) per drive. In this case, a type B RCD must not be located downstream of a type A or AC RCD.

(1) For a complete list of references for TeSys contactors, please refer to the "Motor starter solutions - Control and protection components" and "Motor starters up to 150 A" catalogs or visit "www.schneider-electric.us".

(2) Motor power indicated for combination with an ATV12H0000 drive with the same rating. For combination with an ATV12P0000 drive, refer to the specific manual for the Altivar® 12 base plate version, available on our website at "www.schneider-electric.us".

(3) TeSys motor circuit-breakers:

- GV2ME00: Thermal magnetic motor circuit-breakers with pushbutton control
- GV2L00: Magnetic motor circuit-breakers with control by rotary knob

(4) 4-pole C60N modular circuit-breaker

(5) For additional protection against direct contact, with a three-phase power supply and access to the DC bus terminals (PA/+ and PC/-), the add-on module must be type B with a sensitivity of 30 mA.

| | |
|---------------------------------------------------------------------------------|---------|
| Summary of functions | |
| Factory-set drive configuration | |
| Introduction | page 27 |
| Human/Machine Interface (HMI) | |
| Description | page 27 |
| Application functions | |
| Operating speed range | page 28 |
| Preset speeds | page 28 |
| Three additional high speeds | page 28 |
| Control modes | page 28 |
| PID regulator | page 29 |
| Configuration of the logic input level | page 29 |
| I/O monitoring | page 29 |
| Operating direction: forward/reverse | page 29 |
| 2-wire control | page 29 |
| 3-wire control | page 29 |
| Acceleration and deceleration ramp times | page 29 |
| Ramp time switching | page 30 |
| Acceleration and deceleration ramp profiles | page 30 |
| Deceleration ramp adaptation | page 30 |
| Stop types | page 30 |
| Limiting low speed operating time | page 31 |
| Configuration of analog input AI1 | page 31 |
| Automatic restart | page 31 |
| Automatic catching of a spinning load with speed detection ("catch on the fly") | page 31 |
| 2nd current limit | page 32 |
| Automatic DC injection | page 32 |
| Motor control profiles | page 32 |
| Switching frequency, noise reduction | page 32 |
| Frequency jump | page 32 |
| Jog mode | page 32 |
| Fault relay, unlocking | page 33 |
| Drive thermal protection | page 33 |
| Motor thermal protection | page 33 |
| Monitoring | page 33 |
| Underload detection | page 34 |
| Overload detection | page 34 |
| Fault acknowledgment | page 34 |
| Parameter protection by confidential code | page 34 |
| Configuration of logic output LO+ | page 34 |
| Configuration of analog output AO1 | page 34 |
| Pump-specific application functions | |
| Control in single variable mode | page 35 |
| Control in single variable mode with auxiliary pump | page 35 |
| Underload detection | page 34 |
| Overload detection | page 34 |
| Sleep/Wake-up | page 36 |
| PID feedback supervision | page 36 |
| No-load operation detection | page 36 |
| Quick start | page 37 |
| Automatic restart on underload and overload fault | page 37 |
| PID reference adjustment range for the end user | page 37 |
| Incompatible functions | |
| Introduction | page 37 |



ATV12H075M2 with door on front panel closed with protective cover 5: STOP/RESET and RUN buttons not accessible

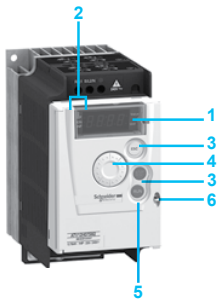

ATV12H075M2 with door on front panel closed without protective cover 5: STOP/RESET and RUN buttons accessible

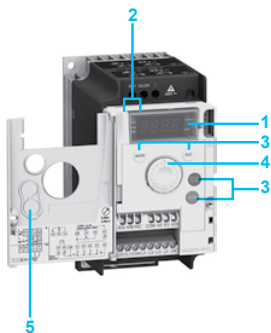

ATV12H075M2 with door on front panel open

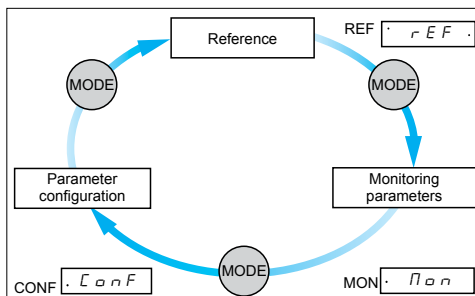

3 operating modes "REF", "MON" and "CONF"

Factory-set drive configuration

The Altivar® 12 drive is configured to allow immediate start-up without any adjustment for the majority of applications.

Factory-set configuration:

Display: Displays the motor frequency reference

Standard motor frequency: 50 Hz

Motor supply voltage: 230 V three-phase

Acceleration and deceleration ramp times: 3 s

Low speed: 0 Hz

High speed: 50 Hz

Motor control profile: Standard (voltage/frequency)

Slip compensation: 100%

Motor thermal current: Same as the nominal motor current

DC injection: 0.7 x nominal motor current for 0.5 s

Switching frequency: 4 kHz

Automatic adaptation of deceleration ramp

2-wire transition detection control: Logic input LI1 is assigned to forward, logic inputs LI2, LI3 and LI4 are not assigned

Logic output LO+: Not assigned

Analog input AI1: 5 V (speed reference)

Analog output AO1: Not assigned

Fault relay R1: 1 N/O contact (R1A, R1C) which opens in the event of a fault or when the drive is powered down

Human/Machine Interface (HMI)

Description

1 Display:

4-digit display

Display of numeric values and codes

Unit rating of displayed value

2 Display of drive status:

"REF": Reference mode. This mode is used to display the motor frequency reference of the active reference channel (terminals, local mode, remote display terminal or Modbus® serial link). In local mode, the reference can be modified using the navigation button 4, if the function has been configured.

"MON": Monitoring mode. This mode is used to display the monitoring parameters.

"CONF": Configuration mode. This mode is used to configure the drive parameters. It offers direct access to the "MyMenu" menu which includes the 9 most commonly used parameters in standard applications. This list can be modified using the SoMove setup software and can contain up to 25 parameters.

All configurable parameters can also be accessed with the "Full" menu for applications requiring further adjustment.

3 Using the buttons:

"MODE": Selects one of the following modes:

"REF" reference mode

"MON" monitoring mode

"CONF" configuration mode

Note: This button cannot be accessed when the door on the front panel is closed.

"ESC": Aborts a value, a parameter or a menu to return to the previous selection.

"STOP/RESET": Controls motor stopping and drive fault clearing locally; button active in factory-set configuration.

"RUN": Controls motor operation locally, if it has been programmed as active.

4 Using the navigation button:

Rotation: Increases or decreases the parameter value, goes to the next parameter and can also be used to switch from one mode to another.

Press: Saves the current value, selects the value.

Option of using the button as a potentiometer in local mode.

5 Protective cover which can be removed to allow access to the STOP/RESET and RUN buttons

6 Mechanical lock for locking the door on the front panel

Application functions

Operating speed range

Determines the two frequency limits which define the speed range permitted by the machine under actual operating conditions within the specified torque limits.

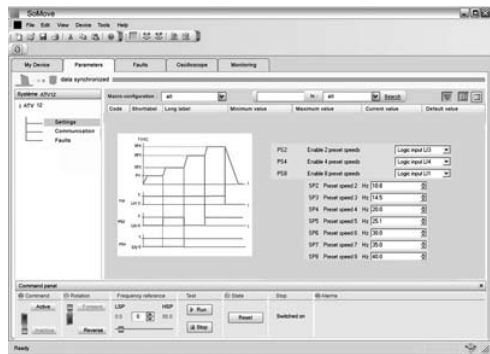
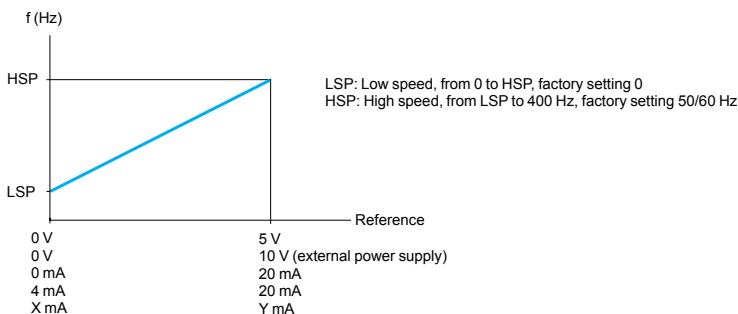

Setting preset speeds with the SoMove setup software

Preset speeds

This is used to switch preset speed references.
Choice of between two and eight preset speeds.
Enabled by means of between 1 and 4 logic inputs.
The preset speeds are adjustable in increments of 0.1 Hz from 0 Hz to 400 Hz.
They take priority over the reference given by the active control channel (analog input or the navigation button).

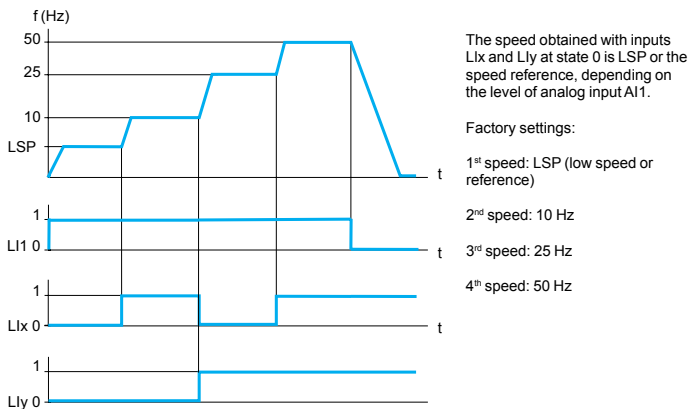

Example of operation with 4 preset speeds

Three additional high speeds

These three additional high speeds are defined by HSP2, HSP3 and HSP4.
They are used to select 2 or 4 high speeds (HSP/HSP2 or HSP/HSP2/HSP3/HSP4).
Enabling 2 or 4 high speeds requires the use of 1 or 2 logic inputs respectively.

Control modes

There are several control and reference channels which can be independent.
Commands (forward, reverse, etc.) and speed references can be sent via the following channels:

- Terminals (logic and analog I/O)
- Local mode (STOP/RESET and RUN buttons and the navigation button)
- Remote display terminal
- Modbus® serial link

The control and reference channels can be separate (separate mode).
Example: The Run/Stop commands come from the terminals and the speed reference comes from the Modbus serial link.
The control and reference channels can also come from the same source (not separate mode).

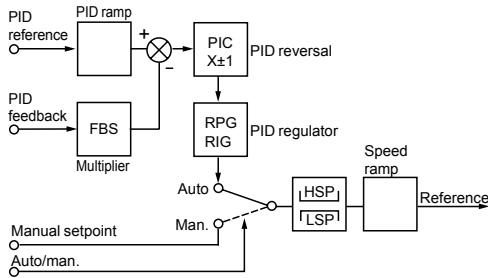

FBS: PID feedback multiplication coefficient
 HSP: High speed
 PIC: Change of direction of PID regulator correction
 LSP: Low speed
 RIG: PID regulator integral gain
 RPG: PID regulator proportional gain
PID regulator

PID regulator

Used for simple control of a flow rate or a pressure with a sensor which supplies a feedback signal adapted to the drive. This function is suitable for pump and fan applications.

□ PID reference

Regulation reference selected from all the possible types:

- Internal reference, representing 0 to 100% of the reference signal. This signal depends on the machine process.
- 2 or 4 preset PID references, adjustable from 0 to 100% of the maximum frequency. This signal depends on the machine process. These references require the use of 1 or 2 logic inputs respectively.
- Manual reference, given by the navigation button.

□ PID feedback

- Analog input AI1

□ Auto/Man.

- Logic input LI for switching operation to speed reference (Man.) or PID regulation (Auto)

During operation in automatic mode, it is possible to adapt the process feedback, to correct inverse PID and to adjust the proportional and integral gains. The motor speed is limited to between LSP and HSP.

Configuration of the logic input level

Activates the function to the logic input, whether at high logic level or low logic level, if permitted by the safety rules.

Example: Ramp switching is assigned to logic input LI2; this function is active if LI2 changes to high or low logic level depending on the configuration.

I/O monitoring

Shows the logic state of inputs LI1, LI2, LI3 and LI4 and outputs LO+ and R1 on the 4-digit display.

Operating direction: forward/reverse

2-wire control: Forward operation is always assigned to logic input LI1. Reverse operation can be assigned to logic input LI2, LI3 or LI4.

3-wire control: Stop is always assigned to logic input LI1 and forward operation is always assigned to logic input LI2. Reverse operation can be assigned to either logic input LI3 or LI4.

2-wire control

Controls the direction of operation by means of a stay-put contact (permanent contact, stable logic level 0 or 1, switch).

Run (forward or reverse) and stop commands are controlled by the same logic input. Enabled by means of 1 or 2 logic inputs (non-reversing or reversing).

See page 22 for the connection diagram.

Three operating modes are possible:

- Detection of the state of the logic inputs
- Detection of a change in state of the logic inputs
- Detection of the state of the logic inputs with forward operation always having priority over reverse

3-wire control

Controls the operating direction and stopping by means of pulsed contacts (pushbutton-operated temporary contact).

Run (forward or reverse) and stop commands are controlled by 2 different logic inputs. Enabled by means of 2 or 3 logic inputs (non-reversing or reversing).

See page 22 for the connection diagram.

Acceleration and deceleration ramp times

This function is used to define acceleration and deceleration ramp times according to the application and the machine dynamics. Each ramp time can be set separately between 0.1 and 999.9 s. Factory-set configuration: 3 s.

Ramp time switching

This function is used to switch two acceleration and deceleration ramp times, which can be set separately.

Enabled by means of 1 assignable logic input.

It is suitable for machines with fast speed correction in steady state and high-speed lathes with acceleration and deceleration limiting above certain speeds.

Acceleration and deceleration ramp profiles

This function can be used to gradually increase the output frequency starting from a speed reference, following a linear profile or a preset profile.

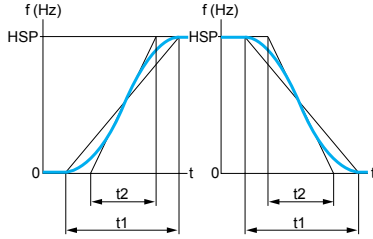

HSP: High speed
 $t1 = k1 \times t2$ ($k1$: fixed rounding coefficient)
 $t2$: Ramp time set

S ramps

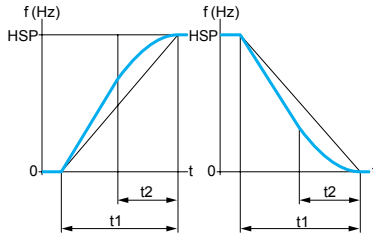

HSP: High speed
 $t1 = k2 \times t2$ ($k2$: fixed rounding coefficient)
 $t2$: Ramp time set

U ramps

S ramps

The use of S ramps is dedicated to applications involving handling, packaging and passenger transport; this method takes up mechanical backlash and eliminates jolts, and also limits “non-following” of speed during rapid transient operation of high-inertia machines.

U ramps

The use of U ramps is dedicated to pump applications such as an installation with centrifugal pump and non-return valve; this method enables valve closing to be controlled more accurately.

Selecting “linear”, “S”, or “U” profiles will affect both the acceleration and deceleration ramps.

Automatic adaptation of deceleration ramp

This function is used to increase the deceleration time automatically if the initial setting is too low when the load inertia is taken into account. It prevents the drive locking on an “overvoltage on deceleration” fault.

If a braking unit is connected to the drive, this function must be disabled.

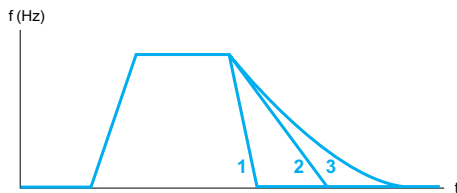

1 Fast stop
 2 Stop on deceleration ramp
 3 Freewheel stop

Stop types

Stop types

This is used to define the drive stop mode.

There are three stop types:

- Freewheel stop: When the drive is locked, the motor stops in freewheel mode depending on the application; the motor power supply is cut.
- Stop on deceleration ramp: The motor stops according to the deceleration ramp time which can be fixed or adaptable (see the “Automatic adaptation of deceleration ramp” function).
- Fast stop: Braked stop with an acceptable deceleration ramp time (divided by a coefficient which can be set between 1 and 10) for the drive/motor unit without locking in the event of an “overvoltage on deceleration” fault.

Factory-set configuration: Stop on 3 s deceleration ramp with automatic adaptation.

Limiting low speed operating time

The motor is stopped automatically after a period of operation at low speed (LSP). This time can be set between 0.1 and 999 seconds (0 corresponds to an unlimited time).

The motor restarts automatically on a ramp when the reference reappears. This function is suitable for automatic stops/starts, especially in pump applications.

Configuration of analog input AI1

This is used to modify the specifications, for either voltage or current, of analog input AI1.

Factory-set configuration: 0-5 V (internal power supply).

Other possible values via external power supply: 0-10 V, X-Y mA by programming X and Y with 0 to 20 mA.

Automatic restart

This function enables the drive to be restarted automatically after it has locked in fault mode, provided the relevant fault has disappeared and the other operating conditions permit a restart.

This restart is performed by a series of automatic attempts separated by increasingly long waiting periods of 1 s, 5 s, 10 s, then 1 min for subsequent periods.

If the drive has not restarted after 6 minutes, it locks and the procedure is abandoned until the drive is powered down and back up again.

Factory-set configuration: Function inactive.

Restarting is permitted with the following faults:

- Drive thermal overload
- Motor thermal overload
- Line overvoltage
- Overvoltage during deceleration
- Motor overload
- Motor underload
- Output phase loss
- Input phase loss (1)
- Line undervoltage (2)
- Modbus serial link

For this type of fault, the fault relay remains activated if the function has been configured.

This function requires the speed reference and the direction of operation to be maintained, and is only compatible with 2-wire level control.

This function is suitable for machines or installations which are in continuous operation or are not monitored, and where a restart will not endanger equipment or personnel in any way.

Automatic catching of a spinning load with speed detection (“catch on the fly”)

Used to restart the motor smoothly after one of the following events:

- Loss of line supply or power off
- Fault reset or automatic restart
- Freewheel stop

Once the event is over, the actual motor speed is detected in order to restart on a ramp at this speed and return to the reference speed. The speed detection time can be up to 1 s (typical value) depending on the initial deviation.

Factory-set configuration: Function inactive.

This function requires the “automatic DC injection braking” function to be disabled.

This function is suitable for machines for which the loss of motor speed is negligible during the power failure (machines with high inertia).

(1) The “input phase loss” fault is only accessible on drives with a three-phase power supply, if monitoring of the fault has been enabled (factory-set configuration: enabled).

(2) The drive will restart as soon as the “undervoltage” fault disappears, regardless of whether the function is active.

2nd current limit

A 2nd current limit can be configured between 0.25 and 1.5 times the nominal drive current and can be used to limit the torque and the rise in motor temperature. Switching between the two current limits is enabled via a logic input or via the Modbus serial link.

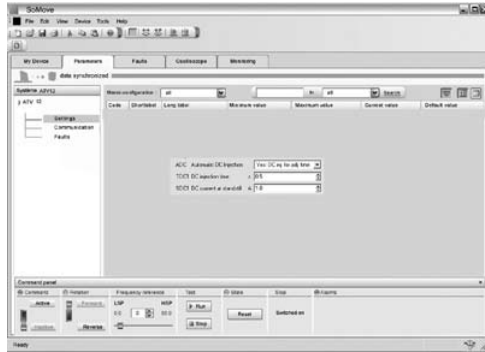

Setting the "DC injection" function with the SoMove setup software

Automatic DC injection

This function enables standstill DC injection, which can be set between 0 and 1.2 times the value of the nominal drive current (factory-set configuration: 0.7 x motor nominal current), as soon as operation is no longer controlled and the motor speed is zero:

- Either for a period of time, which can be set between 0.1 and 30 s
- Or continuously

Factory-set configuration: Function active with DC injection for 0.5 s. In 3-wire control, DC injection is only active if logic output LI1 is active (assigned to stop).

Motor control profiles

Three motor control profiles are available depending on the application requirements:

- Standard (U/F)**: Simple motor control profile maintaining a constant voltage/frequency ratio with an optional low speed setting. Profile suitable for small conveyors, applications with motors connected in parallel, etc.
- Performance (sensorless flux vector control)**: Profile which can guarantee the level of performance with a motor with the same power or one rating less. This profile can be used to obtain improved dynamic specifications at low speed. Profile suitable for running machines, etc.
- Pump/Fan (K/F²)**: Quadratic ratio for obtaining a torque proportional to the square of the speed. This profile can be used to optimize energy consumption according to the load applied to the machine. Profile suitable for pump regulation, air extraction, etc.



Energy saving with the Pump/Fan profile (K/F²)

Switching frequency, noise reduction

The switching frequency setting between 2 and 16 kHz permits a reduction in the noise generated by the motor for any application requiring a low level of noise. The switching frequency can be modulated randomly in order to avoid resonance. This function can be disabled if it causes instability. Switching the DC voltage at high frequency is useful for supplying the motor with a current wave having little harmonic distortion. This type of operation increases drive overheating.

Factory-set configuration: Low frequency set at 4 kHz.

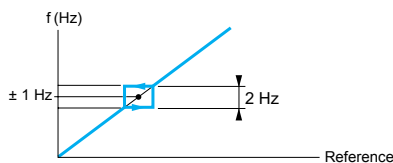

Frequency jump in relation to the resonance point

Frequency jump

Used to pass a mechanical resonance point likely to cause increased noise or risk of mechanical breakdown. The frequency jump is fixed. It is within ± 1 Hz of the configured resonance point.

Jog mode

This can be used for pulse operation with minimum ramp times (0.1 s), a fixed speed reference set at 5 Hz and minimum time of 0.5 s between 2 pulses. Enabled by 1 logic input and pulses issued by the operating direction command. This function is suitable for machines with product insertion in manual mode (for example, gradual movement of the mechanism during maintenance operations).

Fault relay, unlocking

The fault relay is energized when the drive is powered up and is not faulty. It opens in the event of a fault or when the drive is powered down.

The drive can be unlocked after a fault in one of the following ways:

- By powering down the drive until the display disappears completely, then powering back up
- By activating the logic input associated with the “fault reset” function, if the function is enabled
- By enabling the “automatic restart” function

Drive thermal protection

Thermal protection is integrated in the drive. When the fault is detected, it locks the drive.

Depending on the model, the drive is equipped with a fan.

The drive optimizes management of fan operation in order to reduce the amount of maintenance work and the equipment noise level.

Motor thermal protection

The theoretical temperature rise of the motor is continuously calculated to provide thermal protection.

The drive calculates this temperature rise using the following elements:

- The operating frequency
 - The current taken by the motor
 - The operating time
 - The type of motor ventilation (self-cooled or force-cooled)
- Thermal protection can be set at anything from 0.2 times the nominal drive current. It must be set to the nominal current indicated on the motor rating plate.

Note: When the power supply is de-energized, the motor thermal state may or may not be stored, depending on the chosen configuration.

Monitoring

The display shows the state of the drive or, if selected, one of the following values:

- Frequency reference
- Output frequency applied to the motor
- Motor current
- Line voltage
- Output power
- Motor thermal state
- Drive thermal state
- PID error
- PID feedback
- PID reference
- Motor operating status (stop, forward, reverse, run, acceleration, deceleration, braking, freewheel stop, etc.)

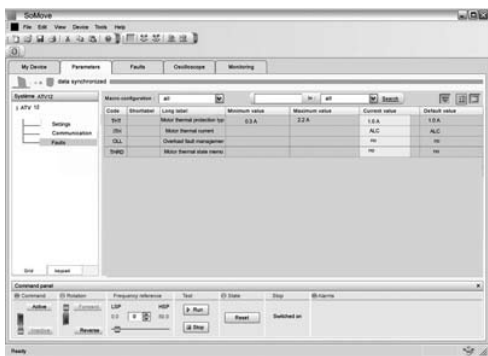

Setting the motor thermal protection with the SoMove setup software

Underload detection

This function stops the motor when it is underloaded. The function is active in steady state.

If the current is below an underload threshold for an adjustable period of time, the drive locks in underload fault mode.

The current threshold is adjustable between 20% and 100% of the nominal motor current value.

Hysteresis of 10% is applied to this threshold to confirm the end of underload conditions. The time delay is adjustable up to 100 s. When this parameter is at 0, the function is deactivated.

This function is particularly suitable for protecting pumps during cavitation.

Overload detection

This function stops the motor when it is overloaded. The function is active in steady state.

If the motor current is higher than an overload threshold for an adjustable period of time, the drive locks in overload fault mode.

The overload threshold can be set to between 70% and 150% of the nominal motor current.

Hysteresis of 10% is applied to this threshold to confirm the end of overload conditions.

The time delay can be set at anything up to 100 s. When this parameter is at 0, the function is deactivated.

Fault acknowledgment

This is used to clear the stored fault and restart the drive if the cause of the fault has disappeared.

The fault is cleared by a transition of the logic input LI which is assigned to this function.

Factory-set configuration: Function inactive.

The restart conditions after a reset are the same as those of a normal power-up.

The following faults can be reset (1): drive thermal overload, motor thermal overload, line overvoltage, overvoltage on deceleration, overspeed, input phase loss (2), etc.

Parameter protection by confidential code

This function protects the drive configuration using an access code.

Configuration of logic output LO+

Logic output LO+ enables remote signalling of the following information as required:

- Malfunction
- Operation
- Frequency threshold attained
- High speed attained
- Current threshold attained
- Frequency reference attained
- Motor thermal state attained
- 4-20 mA monitoring
- Underload detected
- Overload detected
- Operation of the auxiliary pump with the "Control in single variable mode with auxiliary pump" function

Configuration of analog output AO1

Analog output AO1 enables remote signalling of the following information as required:

- Motor current
- Motor frequency
- Ramp output
- PID error
- PID feedback
- PID reference
- Output power
- Motor thermal state
- Drive thermal state

(1) See the complete list of faults in the Altivar® 12 Programming Manual, available on our website at "www.schneider-electric.us".

(2) The "input phase loss" fault is only accessible on drives with a three-phase power supply, if monitoring of the fault has been enabled (factory-set configuration: enabled).

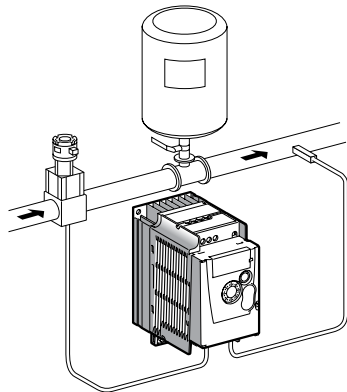

Single variable mode

1

Pump-specific application functions

The main objective here is to control a complete pumping installation using a single Altivar® 12 drive by ensuring constant pressure in the system whatever the flow rate. The Altivar 12 has 11 functions designed for water pumping applications:

- Control in single variable mode
- Control in single variable mode with auxiliary pump
- Underload detection
- Overload detection
- Sleep
- Wake-up
- PID feedback supervision
- No-load operation detection
- Quick start
- Automatic restart on underload and overload faults
- PID reference adjustment range for the end user

Control in single variable mode

The system is operated using a single variable speed pump (1). A PID regulator controls the variable speed pump. A pressure sensor provides the "PID feedback" information required for system feedback.

Control in single variable mode with auxiliary pump

The system is operated using a fixed speed pump, called the auxiliary pump, and a variable speed pump, which is unable to provide the full flow range required on its own (2).

The auxiliary pump's starting and stopping are controlled by logic output LO+ according to the PID regulator output (variable pump frequency reference) with a hysteresis effect as shown in the diagram below (3).

Auxiliary pump starting (4)

If the variable pump control frequency exceeds the threshold (FO_n) for longer than a time period (t_{On}), the auxiliary pump is put into operation (1). The variable pump reference decreases linearly until it reaches the threshold (FOF). In order to reduce the effect of overpressure caused by starting of the auxiliary pump, the deceleration time of the variable pump (r_{On}) must be set to the time that the auxiliary pump takes to reach its nominal speed.

Auxiliary pump stopping (5)

Conversely, if the variable pump control frequency falls below the threshold (FOF) for a period (t_{OF}), the auxiliary pump is stopped (2) and the variable pump reference increases linearly until it reaches the threshold (FO_n). The acceleration time (r_{OF}) is set to the stopping time of the auxiliary pump in order to minimize the effect of underpressure.

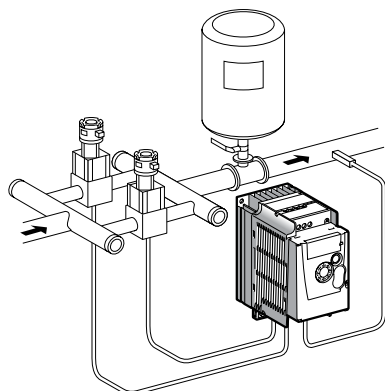

Single variable mode with auxiliary pump

2

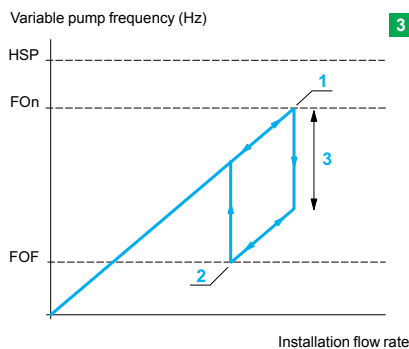

Single variable mode with auxiliary pump: hysteresis

3

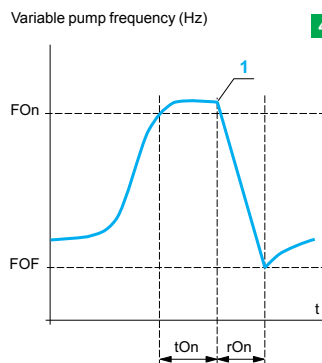

Auxiliary pump start

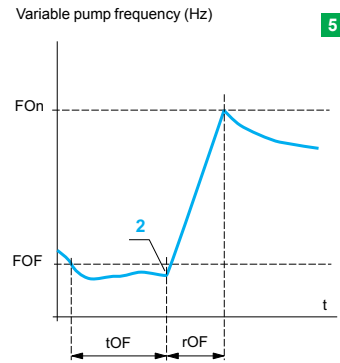

Auxiliary pump stop

- 1 Auxiliary pump starting
 - 2 Auxiliary pump stopping
 - 3 Frequency range corresponding to the auxiliary pump flow rate
- FO_n: Starting frequency of the auxiliary pump
FOF: Stopping frequency of the auxiliary pump

Underload detection

See page 34.

Overload detection

See page 34.

Sleep/Wake-up

Allows the variable pump to come to a complete stop when the flow rate is considered too low, below an adjustable “sleep threshold” (LSP+ SLE) and time delay (tLS).

When the system is in “sleep” state, if the PID feedback value (showing the pressure downstream of the pump) falls below a “wake up” threshold (UPP), the variable pump is restarted.

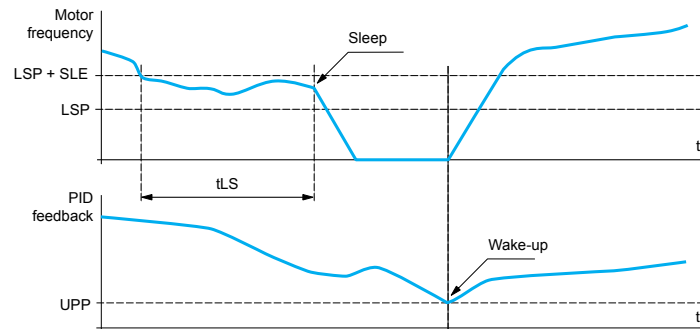

LSP: Low speed
SLE: Sleep threshold offset
UPP: Wake-up threshold
tLS: Sleep threshold operating time

Sleep/Wake-up functions

PID feedback supervision

Once the variable pump is running at maximum speed and at the same time the PID feedback is lower than the supervision threshold (LPI) at the end of a time delay (tPI), the drive switches to fallback mode. There are two possible scenarios (see graphs below):

- The drive performs a freewheel stop and displays a specific fault code **1**.
- Configurable fixed speed operation with display of a specific fault code **2**.

The drive reverts to regulation mode when the PID feedback returns to the supervision threshold (LPI).

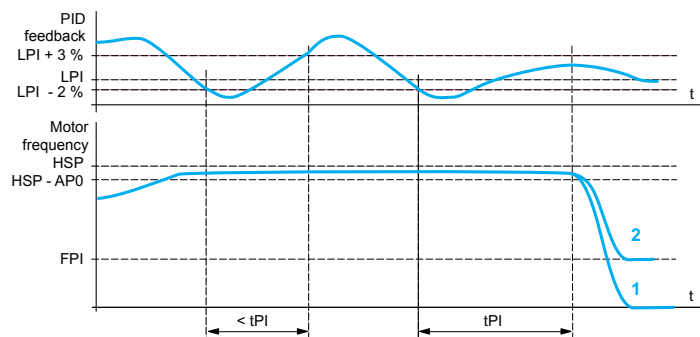

LPI: PID feedback supervision threshold
HSP: High speed
FPI: Fallback speed
APO: Maximum speed detection hysteresis
tPI: PID feedback supervision function time delay

PID feedback supervision

In single variable mode with auxiliary pump, this function is active when both pumps are operating.

No-load operation detection

This function is used in applications where zero flow cannot be detected by the sleep function alone. It is active when the auxiliary pump is stopped and the variable pump motor frequency reference is below a configured threshold.

It consists of periodically forcing the motor frequency reference to a low value:

- If the request is still present, it results in an increase in the PID error and the drive reverts to regulation in line with the previous reference.
- If the request is no longer present (zero flow), the PID error will not change, which is characteristic of no-load operation. The variable pump motor is stopped.

Quick start

The quick start function aims to overcome the problems associated with the high regulation gains that are necessary at start-up but inappropriate for regulation. The drive accelerates linearly on a ramp (ACC) until its speed reaches the configured quick start threshold (SFS). Once it reaches this threshold (SFS), PID regulation begins.

Variable pump frequency

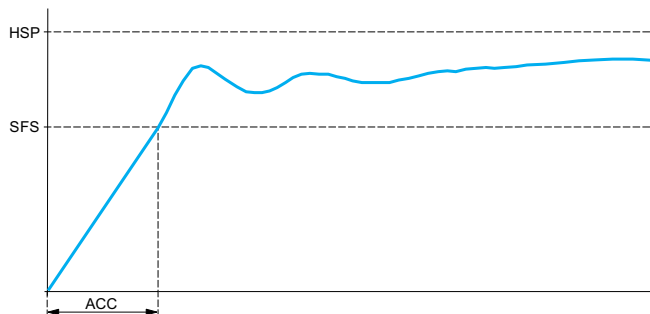

Quick start

HSP: High speed
SFS: Quick start threshold
ACC: Acceleration ramp time

Automatic restart on underload and overload faults

Generally, the user can set a parameter to activate automatic restarting after a fault, if the cause(s) of the fault no longer exist(s). In the case of underload and overload faults, a delay which can be set between 1 s and 6 min 16 s can be used to delay the restart.

PID reference adjustment range for the end user

This function allows the end user to adjust the PID regulator reference to increase or reduce the rate of flow. Adjustment by the user is either by modifying the PID regulator reference parameter, or by manual control of the navigation button, accessible on the drive's front panel. The installer has access to two PID reference limit parameters, which can be used to define a user's range of action.

Incompatible functions

Application functions can be assigned to the same logic input, in which case one logic input enables a number of functions (for example, direction of operation and ramp time switching).

A check must be carried out to ensure that the functions are compatible:

Direction of operation and 2-wire control: Forward operation can only be assigned to LI1.

Direction of operation and 3-wire control: Forward operation can only be assigned to LI2.

Automatic restart: This function requires the configuration of 2-wire level control. Changing the control type configuration deactivates automatic restarting.

Automatic catching of a spinning load with speed detection: Incompatible with continuous standstill DC injection. Configuring this function deactivates automatic catching of a spinning load.

Schneider Electric USA, Inc.

8001 Knightdale Blvd.
Knightdale, NC 27545
Tel: 919-266-3671

19 Waterman Avenue
Toronto, Ontario M4B 1Y2
Tel: 416-752-8020

<http://www.schneider-electric.us/>

The information and dimensions in this catalog are provided for the convenience of our customers. While this information is believed to be accurate, Schneider Electric reserves the right to make updates and changes without prior notification and assumes no liability for any errors or omissions.

Altivar, FIPIO, Modbus, Phaseo, SoMove, TeSys, Twido, Schneider Electric and logo, and "Make the most of your energy" are trademarks or registered trademarks of Schneider Electric or its affiliates in the United States and other countries. Other trademarks used herein are the property of their respective owners.

Design: Schneider Electric
Photos: Schneider Electric