

Form 955-050221

Part Number	Description
SNAP-B4	High-speed Digital Brain, Pamux Protocol

Description

The SNAP-B4 is a high-performance digital brain used to connect and control up to 32 channels of digital I/O using Opto 22's SNAP "B Series" I/O mounting racks and the Pamux bus. The SNAP-B4, combined with Opto 22's AC28 interface card and a host PC, provides the world's fastest digital I/O.

The SNAP-B4 communicates over a 50-pin flat ribbon cable (Pamux bus) and can be located up to 500 feet away from the host processor. The Pamux bus has 64 possible addresses. Each group of eight I/O points occupy one address, therefore the Pamux bus can control up to 512 digital and analog I/O points. Each SNAP-B4 brain controls 32 digital I/O points and occupies four consecutive addresses on the Pamux bus.

For additional technical information about Pamux, please refer to Opto 22 form number 726.

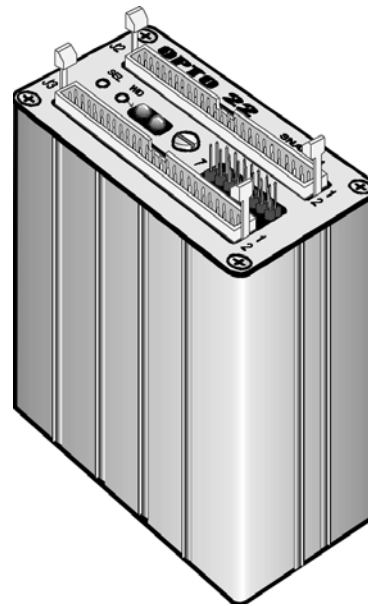

SNAP-B4 Digital Brain

Features

- PAMUX Bus
- Configurable Watchdog Timer
- Digital Only
- Very High Speed
 - 500 I/O Points
 - 500 Microseconds
- Cable Lengths up to 500 Feet

System Architecture

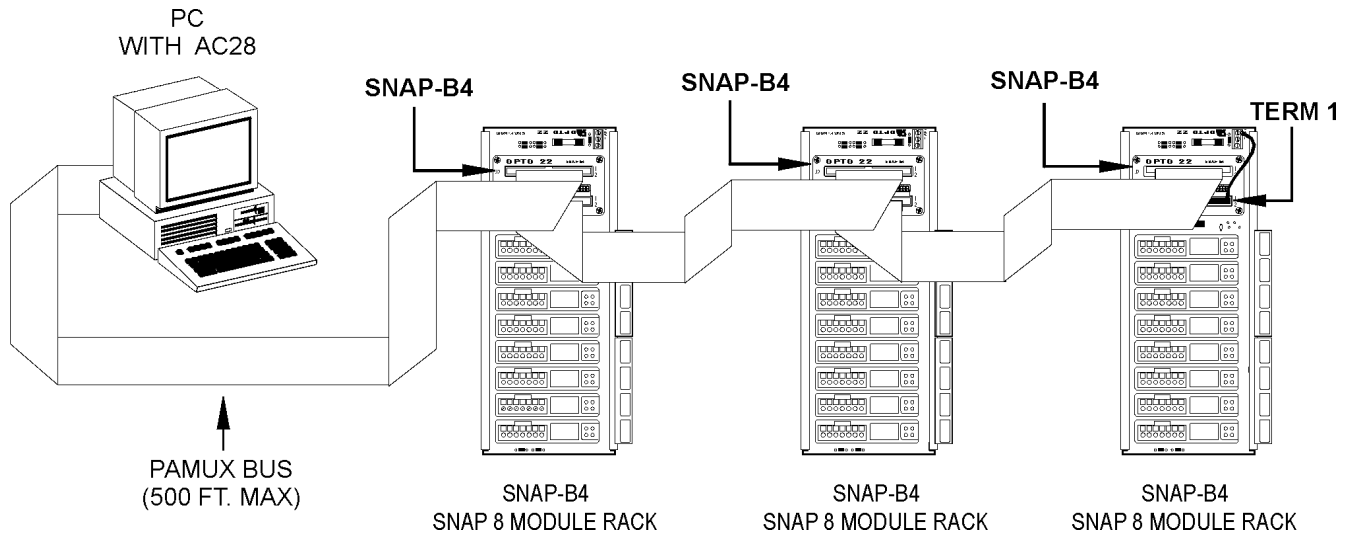

Specifications

General

Power Requirements	5.0 VDC \pm 0.1 VDC @ 1.0A max. (If Term1 installed add 0.5A)
Operating Temperature	0° C to 70° C, 95% humidity, non-condensing
Communications Interface	Pamux Bus; two 50-pin connectors
Range: (Multidrop mode)	Up to 500 feet
LED Indicators	SEL (address selected), WD (watchdog timeout)
Jumpers	0 - 3 Address 4 - 5 Watchdog Timer Function 6 Reset Level 7 Effect of Reset on Channel 0 Watchdog

Form 955-050221

Specifications

B4 Jumpering

Please refer to the tables on this page for SNAP-B4 jumper functions.

Notes:

1. The B4 can only be jumpered for addresses that are either zero or a multiple of four.
2. The B4's watchdog timeout value is a function of hardware and is not user-configurable. An on-board RC circuit sets the watchdog between 1.0 and 2.25 seconds.

Address Jumpers

3 2 1 0				3 2 1 0			
0	<input type="checkbox"/>	<input type="checkbox"/>	<input type="checkbox"/>	32	<input checked="" type="checkbox"/>	<input type="checkbox"/>	<input type="checkbox"/>
4	<input type="checkbox"/>	<input type="checkbox"/>	<input checked="" type="checkbox"/>	36	<input checked="" type="checkbox"/>	<input type="checkbox"/>	<input checked="" type="checkbox"/>
8	<input type="checkbox"/>	<input checked="" type="checkbox"/>	<input type="checkbox"/>	40	<input checked="" type="checkbox"/>	<input checked="" type="checkbox"/>	<input type="checkbox"/>
12	<input type="checkbox"/>	<input type="checkbox"/>	<input checked="" type="checkbox"/>	44	<input checked="" type="checkbox"/>	<input checked="" type="checkbox"/>	<input checked="" type="checkbox"/>
16	<input checked="" type="checkbox"/>	<input type="checkbox"/>	<input type="checkbox"/>	48	<input checked="" type="checkbox"/>	<input type="checkbox"/>	<input type="checkbox"/>
20	<input checked="" type="checkbox"/>	<input type="checkbox"/>	<input checked="" type="checkbox"/>	52	<input checked="" type="checkbox"/>	<input checked="" type="checkbox"/>	<input checked="" type="checkbox"/>
24	<input type="checkbox"/>	<input checked="" type="checkbox"/>	<input type="checkbox"/>	56	<input checked="" type="checkbox"/>	<input checked="" type="checkbox"/>	<input type="checkbox"/>
28	<input type="checkbox"/>	<input checked="" type="checkbox"/>	<input checked="" type="checkbox"/>	60	<input checked="" type="checkbox"/>	<input checked="" type="checkbox"/>	<input checked="" type="checkbox"/>

= JUMPER INSTALLED

= NO JUMPER

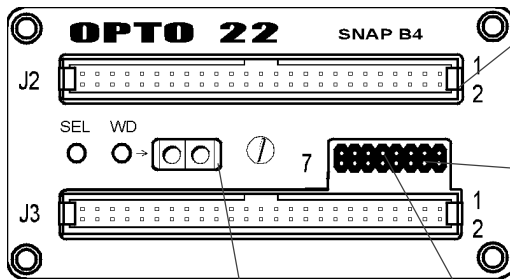

Watchdog Timer Jumpers

Jumper 4	Jumper 5	Watchdog	Action
In	In	Active	No Action
Out	In	Active	Activate Channel 0
In	Out	Active	Deactivate all Channels
Out	Out	Active	Activate 0, all others Deactivate

LED Descriptions

LED	Description
WD	Watchdog timer has expired
ADR	Address lines on Pamux bus match jumper address

Jumper 6	Jumper 7	Action
Out	X	Logic Low Reset
In	X	Logic High Reset

Jumper 7	Action
Out	Reset has no effect on Channel 0 watchdog operation
Installed	Reset Active before Watchdog Timeout: All outputs off until Reset off, then normal watchdog function
Installed	Watchdog Timeout then Reset Active: Normal Watchdog function; subsequent Reset has no effect

Form 955-050221

Specifications

B4 I/O Mapping

I/O on the SNAP-B4 is divided into four addresses of digital I/O, each with eight channels as follows:

First two module positions (0-1): The 8 digital channels of B4 Base Address + 0.

Second two module positions (2-3): The 8 digital channels of B4 Base Address + 1.

Third two module positions (4-5): The 8 digital channels of B4 Base Address + 2.

Fourth two module positions (6-7): The 8 digital channels of B4 Base Address + 3.

If a SNAP-B4 brain is configured at address 12, the digital addresses used by that SNAP-B4 would be 12, 13, 14, and 15.

Note:
Base address set by
jumpers on brain board

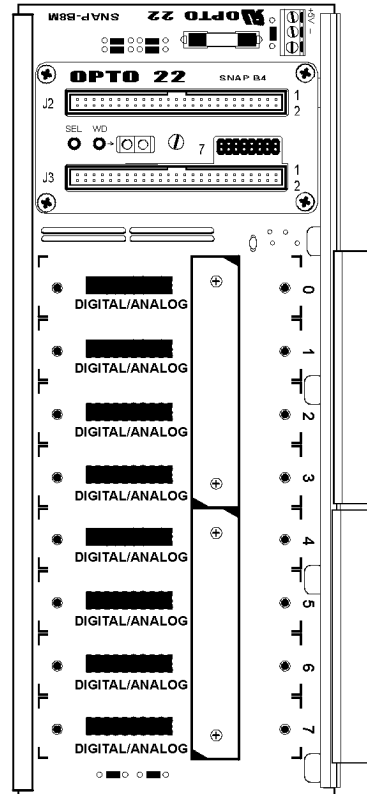
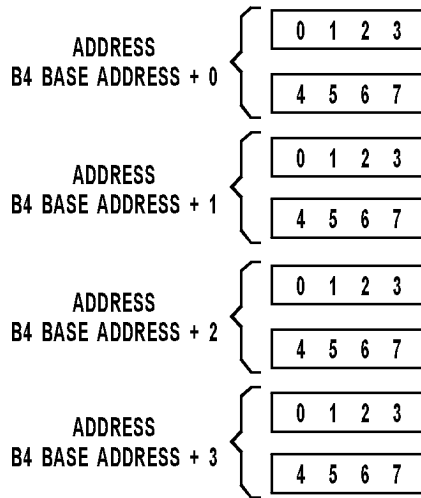
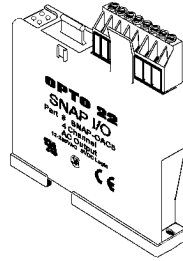

SNAP I/O Rack

Form 955-050221

Dimensional Drawing

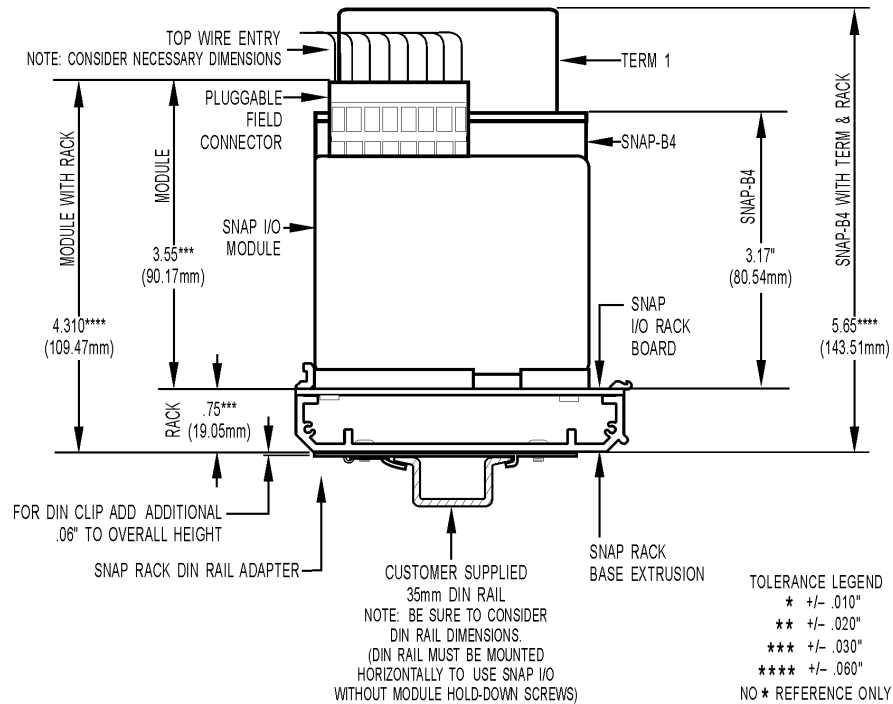
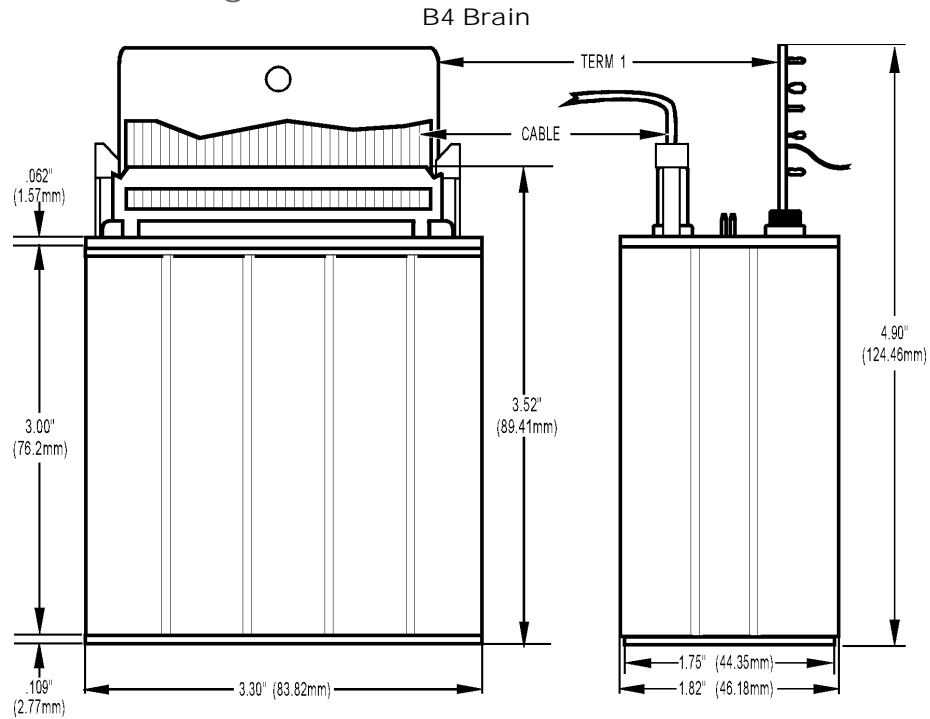

Form 955-050221

Assembly

Brain and Mounting Rack

To install SNAP-B4 onto B Series rack:

1. Turn off power to rack assembly.
2. If a plastic brain insulator is present on your mounting rack, remove as shown below
3. Align the brain connector with mating connector on rack.
4. Seat brain onto connector.
5. Use integral hold-down screw to secure in position. Do not overtighten.
6. If Term 1 is used install as shown.
Note: Term 1 is only for the last physical connection to Pamux bus.

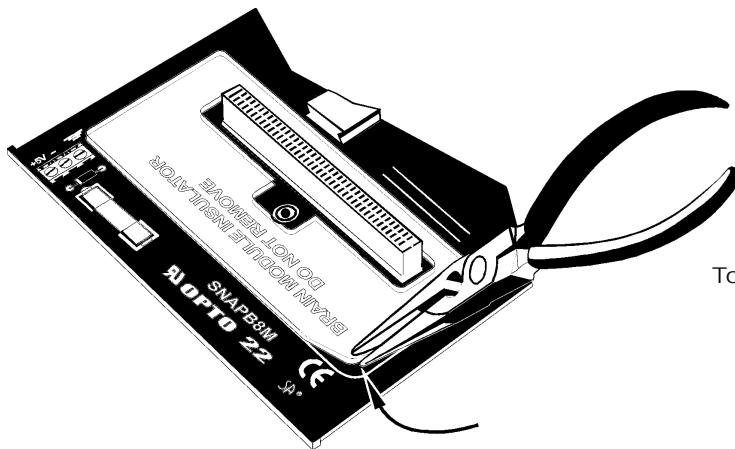
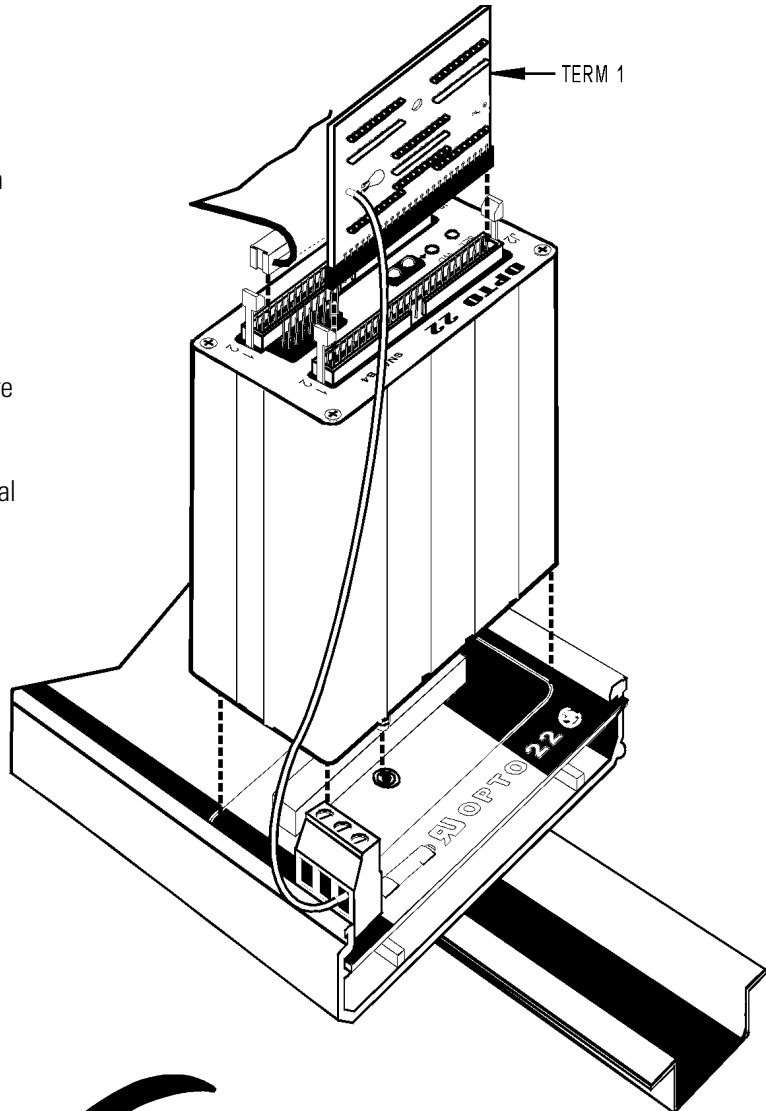

To remove SNAP-B4 from B Series rack:

1. Turn off power to rack assembly.
2. Loosen integral hold-down screw on SNAP-B4 processor.
3. Pull up on processor.

Products

Opto 22 produces a broad array of reliable, flexible hardware and software products for industrial automation, remote monitoring, enterprise data acquisition, and machine-to-machine (M2M) applications.

SNAP Ethernet Systems

Based on the Internet Protocol (IP), SNAP Ethernet systems offer flexibility in their network connectivity and in the software applications they work with. The physical network may be a wired Ethernet network, a cellular wireless network, or a modem. A wide variety of software applications can exchange data with SNAP Ethernet systems, including:

- Opto 22's own ioProject™ suite of control and HMI software
- Manufacturing resource planning (MRP), enterprise management, and other enterprise systems
- Human-machine interfaces (HMIs)
- Databases
- Email systems
- OPC client software
- Custom applications
- Modbus/TCP software and hardware.

SNAP Ethernet system hardware consists of controllers and I/O units. Controllers provide central control and data distribution. I/O units provide local connection to sensors and equipment.



SNAP OEM Systems

Opto 22 SNAP OEM I/O systems are highly configurable, programmable processors intended for OEMs, IT professionals, and others who need to use custom software with Opto 22 SNAP I/O modules.

Linux® applications running on these systems can read and write to analog, simple digital, and serial I/O points on SNAP I/O modules using easily implemented file-based operations. Applications can be developed using several common development tools and environments, including C or C++, Java, and shell scripts.



M2M Systems

Machine-to-machine (M2M) systems connect your business computer systems to the machines, devices, and environments you want to monitor, control, or collect data from. M2M systems often use wireless cellular communications to link remote facilities to central systems over the Internet, or to provide monitoring and control capability via a cellular phone.

Opto 22's Nvio™ systems include everything you need for M2M—interface and communications hardware, data service plan, and Web portal—in one easy-to-use package. Visit nvio.opto22.com for more information.

Opto 22 Software

Opto 22's ioProject and FactoryFloor® software suites provide full-featured and cost-effective control, HMI, and OPC software to power your Opto 22 hardware. These software applications help you develop control automation solutions, build easy-to-use operator interfaces, and expand your manufacturing systems' connectivity.



Quality

In delivering hardware and software solutions for worldwide device management and control, Opto 22 retains the highest commitment to quality. We do no statistical testing; each product is made in the U.S.A. and is tested twice before leaving our 160,000 square-foot manufacturing facility in Temecula, California. That's why we can guarantee solid-state relays and optically-isolated I/O modules *for life*.

Product Support

Opto 22's Product Support Group offers comprehensive technical support for Opto 22 products. The staff of support engineers represents years of training and experience, and can assist with a variety of project implementation questions. Product support is available in English and Spanish from Monday through Friday, 7 a.m. to 5 p.m. PST.

Opto 22 Web Sites

- www.opto22.com
- nvio.opto22.com
- www.internetio.com (live Internet I/O demo)

Other Resources

- OptoInfo CDs
- Custom integration and development
- Hands-on customer training classes.



About Opto 22

Opto 22 manufactures and develops hardware and software products for industrial automation, remote monitoring, enterprise data acquisition, and machine-to-machine (M2M) applications. Using standard, commercially available Internet, networking, and computer technologies, Opto 22's input/output and control systems allow customers to monitor, control, and acquire data from all of the mechanical, electrical, and electronic assets that are key to their business operations. Opto 22's products and services support automation end users, OEMs, and information technology and operations personnel.

Founded in 1974 and with over 85 million Opto 22-connected devices deployed worldwide, the company has an established reputation for quality and reliability.