



# DRAM

## MT4LC4M4B1, MT4C4M4B1 MT4LC4M4A1, MT4C4M4A1

For the latest data sheet, please refer to the Micron Web site: [www.micronsemi.com/mti/msp/html/datasheet.html](http://www.micronsemi.com/mti/msp/html/datasheet.html)

### FEATURES

- Industry-standard x4 pinout, timing, functions, and packages
- High-performance, low-power CMOS silicon-gate process
- Single power supply (+3.3V ±0.3V or +5V ±0.5V)
- All inputs, outputs and clocks are TTL-compatible
- Refresh modes: RAS#-ONLY, HIDDEN and CAS#-BEFORE-RAS# (CBR)
- Optional self refresh (S) for low-power data retention
- 11 row, 11 column addresses (2K refresh) or 12 row, 10 column addresses (4K refresh)
- FAST-PAGE-MODE (FPM) access
- 5V tolerant inputs and I/Os on 3.3V devices

### OPTIONS

- Voltage
  - 3.3V LC
  - 5V C
- Refresh Addressing
  - 2,048 (2K) rows B1
  - 4,096 (4K) rows A1
- Packages
  - Plastic SOJ (300 mil) DJ
  - Plastic TSOP (300 mil) TG
- Timing
  - 50ns access -5
  - 60ns access -6
- Refresh Rates
  - Standard Refresh None
  - Self Refresh (128ms period) S\*

NOTE: 1. The 4 Meg x 4 FPM DRAM base number differentiates the offerings in one place—MT4LC4M4B1. The fifth field distinguishes various options: B1 designates a 2K refresh and A1 designates a 4K refresh for FPM DRAMs.

2. The # symbol indicates signal is active LOW.

\*Contact factory for availability

Part Number Example:

**MT4LC4M4B1DJ**

### KEY TIMING PARAMETERS

SPEED	t <sub>RC</sub>	t <sub>RAC</sub>	t <sub>PC</sub>	t <sub>AA</sub>	t <sub>CAC</sub>	t <sub>RP</sub>
-5	84ns	50ns	20ns	25ns	13ns	30ns
-6	110ns	60ns	35ns	30ns	15ns	40ns

### PIN ASSIGNMENT (Top View)

#### 24/26-Pin SOJ

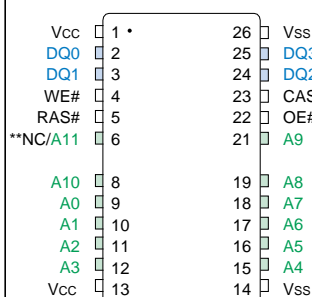

#### 24/26-Pin TSOP

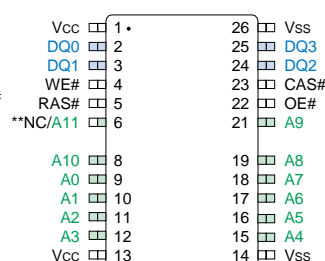

\*\*NC on 2K refresh and A11 on 4K refresh options.

### 4 MEG x 4 FPM DRAM PART NUMBERS

PART NUMBER	V <sub>CC</sub>	REFRESH ADDRESSING	PACKAGE	REFRESH
MT4LC4M4B1DJ-6	3.3V	2K	SOJ	Standard
MT4LC4M4B1DJ-6S	3.3V	2K	SOJ	Self
MT4LC4M4B1TG-6	3.3V	2K	TSOP	Standard
MT4LC4M4B1TG-6S	3.3V	2K	TSOP	Self
MT4LC4M4A1DJ-6	3.3V	4K	SOJ	Standard
MT4LC4M4A1DJ-6S	3.3V	4K	SOJ	Self
MT4LC4M4A1TG-6	3.3V	4K	TSOP	Standard
MT4C4M4A1TG-6S	3.3V	4K	TSOP	Self
MT4C4M4B1DJ-6	5V	2K	SOJ	Standard
MT4C4M4B1DJ-6S	5V	2K	SOJ	Self
MT4C4M4B1TG-6	5V	2K	TSOP	Standard
MT4C4M4B1TG-6S	5V	2K	TSOP	Self
MT4C4M4A1DJ-6	5V	4K	SOJ	Standard
MT4C4M4A1DJ-6S	5V	4K	SOJ	Self
MT4C4M4A1TG-6	5V	4K	TSOP	Standard
MT4C4M4A1TG-6S	5V	4K	TSOP	Self

## GENERAL DESCRIPTION

The 4 Meg x 4 DRAM is a randomly accessed, solid-state memory containing 16,777,216 bits organized in a x4 configuration. RAS# is used to latch the row address (first 11 bits for 2K and first 12 bits for 4K). Once the page has been opened by RAS#, CAS# is used to latch the column address (the latter 11 bits for 2K and the latter 10 bits for 4K; address pins A10 and A11 are "Don't Care").

READ and WRITE cycles are selected with the WE# input. A logic HIGH on WE# dictates read mode, while a logic LOW on WE# dictates write mode. During a WRITE cycle, data-in (D) is latched by the falling edge of WE# or CAS#, whichever occurs last. If WE# goes LOW prior to CAS# going LOW, the output pins remain open (High-Z) until the next CAS# cycle, regardless of OE#.

A logic HIGH on WE# dictates read mode, while a logic LOW on WE# dictates write mode. During a WRITE cycle, data-in (D) is latched by the falling edge of WE# or CAS#, whichever occurs last. An EARLY WRITE occurs when WE# is taken LOW prior to CAS# falling. A LATE WRITE or READ-MODIFY-WRITE occurs when WE# falls after CAS# is taken LOW. During EARLY WRITE cycles, the data outputs (Q) will remain High-Z regardless of the state of OE#. During LATE WRITE or READ-MODIFY-WRITE cycles, OE# must be taken HIGH to disable the data outputs prior to applying input data. If a LATE WRITE or READ-MODIFY-WRITE is attempted while keeping OE# LOW, no WRITE will occur, and the data outputs will drive read data from the accessed location.

The four data inputs and the four data outputs are routed through four pins using common I/O, and pin direction is controlled by WE# and OE#.

The MT4LC4M4B1 and MT4LC4M4A1 must be refreshed periodically in order to retain stored data.

## FAST PAGE MODE ACCESS

Page operations allow faster data operations (READ, WRITE or READ-MODIFY-WRITE) within a row-address-defined page boundary. The page cycle is always initiated with a row address strobed in by RAS#, followed by a column address strobed in by CAS#.

Additional columns may be accessed by providing valid column addresses, strobing CAS# and holding RAS# LOW, thus executing faster memory cycles. Returning RAS# HIGH terminates the page mode of operation, i.e., closes the page.

## DRAM REFRESH

Preserve correct memory cell data by maintaining power and executing any RAS# cycle (READ, WRITE) or RAS# REFRESH cycle (RAS#-ONLY, CBR, or HIDDEN) so that all combinations of RAS# addresses (2,048 for 2K and 4,096 for 4K) are executed within  $t_{REF}^{(MAX)}$ , regardless of sequence. The CBR and SELF REFRESH cycles will invoke the internal refresh counter for automatic RAS# addressing.

An optional self refresh mode is also available the "S" version. The self refresh feature is initiated by performing a CBR REFRESH cycle and holding RAS# LOW for the specified  $t_{RASS}$ . The "S" option allows the user the choice of a fully static, low-power data retention mode or a dynamic refresh mode at the extended refresh period of 128ms, or 31.25 $\mu$ s per row for a 4K refresh and 62.5 $\mu$ s per row for a 2K refresh, when using a distributed CBR REFRESH. This refresh rate can be applied during normal operation, as well as during a standby or battery backup mode.

The self refresh mode is terminated by driving RAS# HIGH for a minimum time of  $t_{RPS}$ . This delay allows for the completion of any internal refresh cycles that may be in process at the time of the RAS# LOW-to-HIGH transition. If the DRAM controller uses a distributed CBR refresh sequence, a burst refresh is not required upon exiting self refresh. However, if the DRAM controller utilizes RAS#-ONLY or burst CBR refresh sequence, all rows must be refreshed with a refresh rate of  $t_{RC}$  minimum prior to resuming normal operation.

## STANDBY

Returning RAS# and CAS# HIGH terminates a memory cycle and decreases chip current to a reduced standby level. The chip is preconditioned for the next cycle during the RAS# HIGH time.

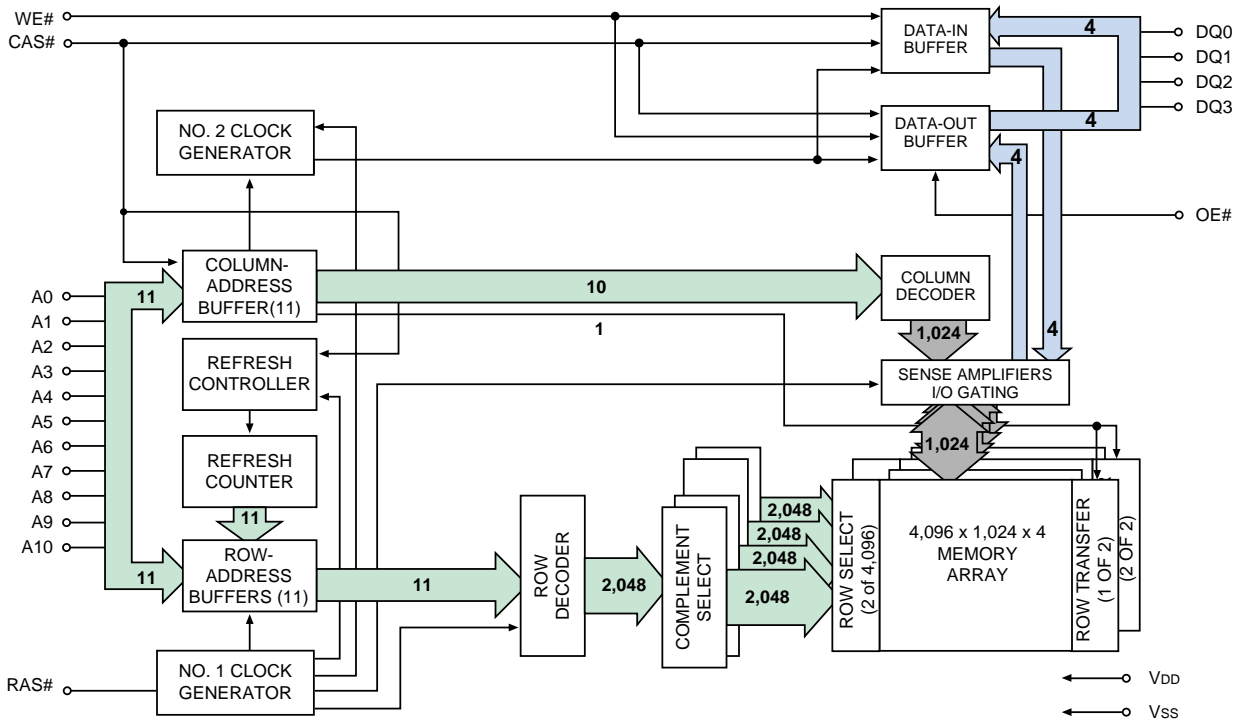
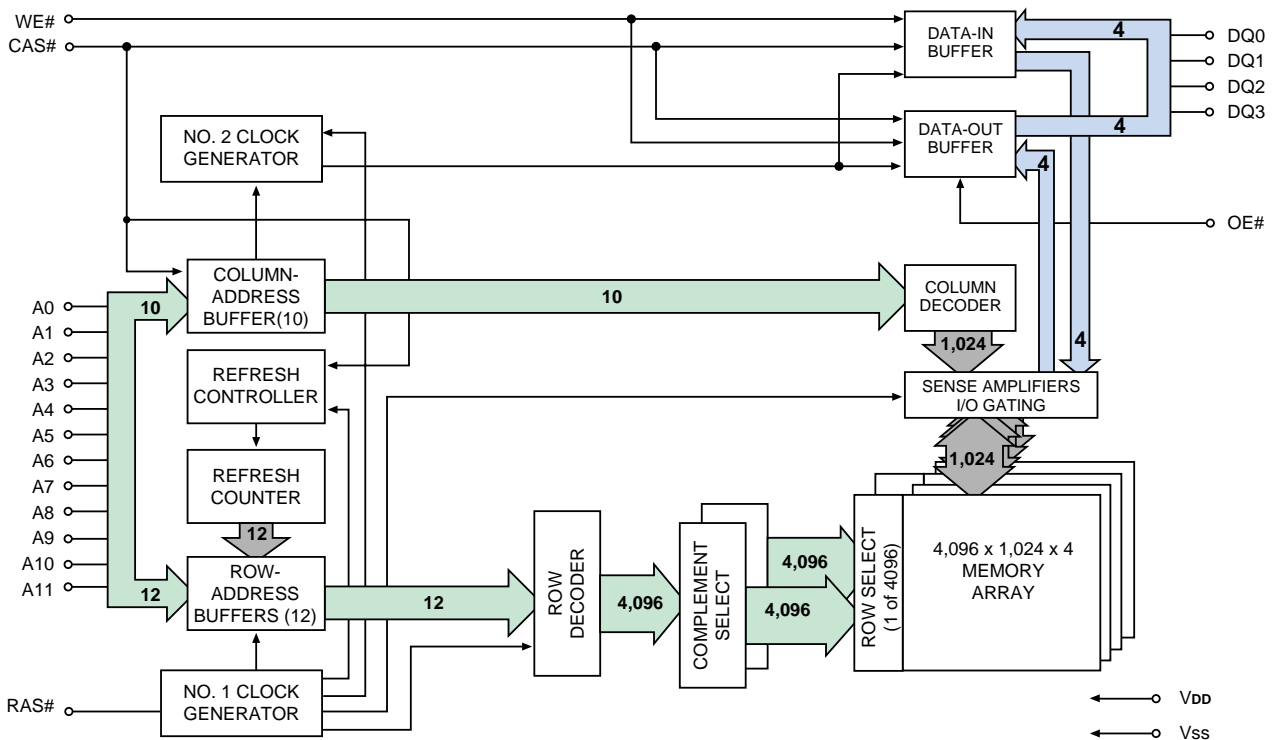
**FUNCTIONAL BLOCK DIAGRAM – 2K REFRESH**

**FUNCTIONAL BLOCK DIAGRAM – 4K REFRESH**

**ABSOLUTE MAXIMUM RATINGS\***

Voltage on V <sub>CC</sub> Pin Relative to V <sub>SS</sub>	
3.3V.....	-1V to +4.6V
5V.....	-1V TO +7V
Voltage on NC, Inputs or I/O Pins Relative to V <sub>SS</sub>	
3.3V.....	-1V to +5.5V
5V.....	-1V TO +7V
Operating Temperature, T <sub>A</sub> (ambient) .... 0°C to +70°C	
Storage Temperature (plastic) ..... -55°C to +150°C	
Power Dissipation ..... 1W	

\*Stresses greater than those listed under “Absolute Maximum Ratings” may cause permanent damage to the device. This is a stress rating only, and functional operation of the device at these or any other conditions above those indicated in the operational sections of this specification is not implied. Exposure to absolute maximum rating conditions for extended periods may affect reliability.

**DC ELECTRICAL CHARACTERISTICS AND OPERATING CONDITIONS**

(Notes: 5, 6) (V<sub>CC</sub> (MIN) ≤ V<sub>CC</sub> ≤ V<sub>CC</sub> (MAX))

PARAMETER/CONDITION	SYMBOL	3.3V		5V		UNITS	NOTES
		MIN	MAX	MIN	MAX		
SUPPLY VOLTAGE	V <sub>CC</sub>	3	3.6	4.5	5.5	V	
INPUT HIGH VOLTAGE: Valid Logic 1; All inputs, I/Os and any NC	V <sub>IH</sub>	2	5.5	2.4	V <sub>CC</sub> +1	V	24
INPUT LOW VOLTAGE: Valid Logic 0; All inputs, I/Os and any NC	V <sub>IL</sub>	-1.0	0.8	-0.5	0.8	V	24
INPUT LEAKAGE CURRENT: Any input at V <sub>IN</sub> [0V ≤ V <sub>IN</sub> ≤ V <sub>CC</sub> (MAX)]; All other pins not under test = 0V	I <sub>I</sub>	-2	2	-2	2	μA	
OUTPUT HIGH VOLTAGE: I <sub>OUT</sub> = -2mA	V <sub>OH</sub>	2.4	-	2.4	-	V	
OUTPUT LOW VOLTAGE: I <sub>OUT</sub> = 2mA	V <sub>OL</sub>	-	0.4	-	0.4	V	
OUTPUT LEAKAGE CURRENT: Any output at V <sub>OUT</sub> [0V ≤ V <sub>OUT</sub> ≤ V <sub>CC</sub> (MAX)]; DQ is disabled and in High-Z state	I <sub>OZ</sub>	-5	5	-5	5	μA	

**I<sub>CC</sub> OPERATING CONDITIONS AND MAXIMUM LIMITS**

 (Notes: 1, 2, 3, 5, 6) [ $V_{CC} (MIN) \leq V_{CC} \leq V_{CC} (MAX)$ ]

PARAMETER/CONDITION	SYM	SPEED	3.3V		5V		UNITS	NOTES
			2K REFRESH	4K REFRESH	2K REFRESH	4K REFRESH		
STANDBY CURRENT: TTL (RAS# = CAS# = V <sub>IH</sub> )	I <sub>CC1</sub>	ALL	1	1	1	1	mA	
STANDBY CURRENT: CMOS (non-"S" version only) (RAS# = CAS# = other inputs = V <sub>CC</sub> - 0.2V)	I <sub>CC2</sub>	ALL	500	500	500	500	mA	
STANDBY CURRENT: CMOS ("S" version only) (RAS# = CAS# = other inputs = V <sub>CC</sub> - 0.2V)	I <sub>CC2</sub>	ALL	150	150	150	150	μA	
OPERATING CURRENT: Random READ/WRITE Average power supply current (RAS#, CAS#, address cycling: <sup>t</sup> RC = <sup>t</sup> RC [MIN])	I <sub>CC3</sub>	-5 -6	110 100	90 80	140 130	120 110	mA	23
OPERATING CURRENT: FAST PAGE MODE Average power supply current (RAS# = V <sub>IL</sub> , CAS#, address cycling: <sup>t</sup> PC = <sup>t</sup> PC [MIN])	I <sub>CC4</sub>	-5 -6	110 100	100 90	110 100	100 90	mA	23
REFRESH CURRENT: RAS#-ONLY Average power supply current (RAS# cycling, CAS# = V <sub>IH</sub> : <sup>t</sup> RC = <sup>t</sup> RC [MIN])	I <sub>CC5</sub>	-5 -6	110 100	90 80	140 130	120 110	mA	
REFRESH CURRENT: CBR Average power supply current (RAS#, CAS#, address cycling: <sup>t</sup> RC = <sup>t</sup> RC [MIN])	I <sub>CC6</sub>	-5 -6	110 100	90 80	140 130	120 110	mA	4, 7
REFRESH CURRENT: Extended ("S" version only) Average power supply current: CAS# = 0.2V or CBR cycling; RAS# = <sup>t</sup> RAS (MIN); WE# = V <sub>CC</sub> - 0.2V; A0-A11, OE# and D <sub>IN</sub> = V <sub>CC</sub> - 0.2V or 0.2V (D <sub>IN</sub> may be left open)	I <sub>CC7</sub>	ALL	300	300	300	300	μA	4, 7
<sup>t</sup> RC		62.5	31.25	62.5	31.25	μs	23	
REFRESH CURRENT: Self ("S" version only) Average power supply current: CBR with RAS# ≥ <sup>t</sup> RAS (MIN) and CAS# held LOW; WE# = V <sub>CC</sub> - 0.2V; A0-A11, OE# and D <sub>IN</sub> = V <sub>CC</sub> - 0.2V or 0.2V (D <sub>IN</sub> may be left open)	I <sub>CC8</sub>	ALL	300	300	300	300	μA	4, 7

**CAPACITANCE**

(Note: 6)

PARAMETER	SYMBOL	MAX	UNITS
Input Capacitance: Address pins	C <sub>I1</sub>	5	pF
Input Capacitance: RAS#, CAS#, WE#, OE#	C <sub>I2</sub>	7	pF
Input/Output Capacitance: DQ	C <sub>IO</sub>	7	pF



## AC ELECTRICAL CHARACTERISTICS

(Notes: 5, 6, 7, 8, 9, 10, 11, 12) [ $V_{CC}(\text{MIN}) \leq V_{CC} \leq V_{CC}(\text{MAX})$ ]

AC CHARACTERISTICS PARAMETER	SYMBOL	-5		-6		UNITS	NOTES
		MIN	MAX	MIN	MAX		
Access time from column address	$t_{AA}$		25		30	ns	
Column-address hold time (referenced to RAS#)	$t_{AR}$	38		45		ns	
Column-address setup time	$t_{ASC}$	0		0		ns	
Row-address setup time	$t_{ASR}$	0		0		ns	
Column address to WE# delay time	$t_{AWD}$	42		49		ns	18
Access time from CAS#	$t_{CAC}$		13		15	ns	
Column-address hold time	$t_{CAH}$	8		10		ns	
CAS# pulse width	$t_{CAS}$	8	10,000	10	10,000	ns	
CAS# LOW to "Don't Care" during Self Refresh	$t_{CHD}$	15		15		ns	
CAS# hold time (CBR Refresh)	$t_{CHR}$	8		10		ns	4
CAS# to output in Low-Z	$t_{CLZ}$	0		0		ns	22
CAS# precharge time	$t_{CP}$	8		10		ns	13
Access time from CAS# precharge	$t_{CPA}$		28		35	ns	
CAS# to RAS# precharge time	$t_{CRP}$	5		5		ns	
CAS# hold time	$t_{CSH}$	38		45		ns	
CAS# setup time (CBR Refresh)	$t_{CSR}$	5		5		ns	4
CAS# to WE# delay time	$t_{CWD}$	28		35		ns	18
WRITE command to CAS# lead time	$t_{CWL}$	8		10		ns	
Data-in hold time	$t_{DH}$	8		10		ns	19
Data-in setup time	$t_{DS}$	0		0		ns	19
Output disable	$t_{OD}$	0	12	0	15	ns	22
Output enable	$t_{OE}$		12		15	ns	20
OE# hold time from WE# during READ-MODIFY-WRITE cycle	$t_{OEH}$	8		10		ns	
Output buffer turn-off delay	$t_{OFF}$	0	12	0	15	ns	17, 22
OE# setup prior to RAS# during HIDDEN REFRESH cycle	$t_{ORD}$	0		0		ns	
FAST-PAGE-MODE READ or WRITE cycle time	$t_{PC}$	20		25		ns	
FAST-PAGE-MODE READ-WRITE cycle time	$t_{PRWC}$	47		56		ns	
Access time from RAS#	$t_{RAC}$		50		60	ns	
RAS# to column-address delay time	$t_{RAD}$	9		12		ns	15
Row-address hold time	$t_{RAH}$	9		10		ns	
RAS# pulse width	$t_{RAS}$	50	10,000	60	10,000	ns	
RAS# pulse width (FAST PAGE MODE)	$t_{RASP}$	50	125,000	60	125,000	ns	
RAS# pulse width during Self Refresh	$t_{RASS}$	100		100		$\mu$ s	
Random READ or WRITE cycle time	$t_{RC}$	84		104		ns	
RAS# to CAS# delay time	$t_{RCD}$	11		14		ns	14
READ command hold time (referenced to CAS#)	$t_{RCH}$	0		0		ns	16
READ command setup time	$t_{RCS}$	0		0		ns	
Refresh period (2,048 cycles)	$t_{REF}$		32		32	ms	
Refresh period (4,096 cycles)	$t_{REF}$		64		64	ms	



## AC ELECTRICAL CHARACTERISTICS

(Notes: 5, 6, 7, 8, 9, 10, 11, 12) [ $V_{CC} (MIN) \leq V_{CC} \leq V_{CC} (MAX)$ ]

AC CHARACTERISTICS		-5		-6			
PARAMETER	SYMBOL	MIN	MAX	MIN	MAX	UNITS	NOTES
Refresh period "S" version	$t_{REF}$		128		128	ms	140
RAS# precharge time	$t_{RP}$	30		40		ns	
RAS# to CAS# precharge time	$t_{RPC}$	5		5		ns	
RAS# precharge time exiting Self Refresh	$t_{RPS}$	90		105		ns	
READ command hold time (referenced to RAS#)	$t_{RRH}$	0		0		ns	16
RAS# hold time	$t_{RSH}$	13		15		ns	
READ-WRITE cycle time	$t_{RWC}$	116		140		ns	
RAS# to WE# delay time	$t_{RWD}$	67		79		ns	19
WRITE command to RAS# lead time	$t_{RWL}$	13		15		ns	
Transition time (rise or fall)	$t_T$	2	50	2	50	ns	
WRITE command hold time	$t_{WCH}$	8		10		ns	
WRITE command hold time (referenced to RAS#)	$t_{WCR}$	38		45		ns	
WE# command setup time	$t_{WCS}$	0		0		ns	18
WRITE command pulse width	$t_{WP}$	5		5		ns	
WE# hold time (CBR Refresh)	$t_{WRH}$	8		10		ns	4, 23
WE# setup time (CBR Refresh)	$t_{WRP}$	8		10		ns	4, 23



**NOTES**

1. All voltages referenced to  $V_{SS}$ .
2. This parameter is sampled.  $V_{CC} = +3.3V$  or  $5.0V$ ;  $f = 1$  MHz.
3.  $I_{CC}$  is dependent on output loading and cycle rates. Specified values are obtained with minimum cycle time and the outputs open.
4. Enables on-chip refresh and address counters.
5. The minimum specifications are used only to indicate cycle time at which proper operation over the full temperature range is ensured.
6. An initial pause of  $100\mu s$  is required after power-up, followed by eight RAS# refresh cycles (RAS#-ONLY or CBR with WE# HIGH), before proper device operation is ensured. The eight RAS# cycle wake-ups should be repeated any time the  $t_{REF}$  refresh requirement is exceeded.
7. AC characteristics assume  $t_T = 5ns$ .
8.  $V_{IH}$  (MIN) and  $V_{IL}$  (MAX) are reference levels for measuring timing of input signals. Transition times are measured between  $V_{IH}$  and  $V_{IL}$  (or between  $V_{IL}$  and  $V_{IH}$ ).
9. In addition to meeting the transition rate specification, all input signals must transit between  $V_{IH}$  and  $V_{IL}$  (or between  $V_{IL}$  and  $V_{IH}$ ) in a monotonic manner.
10. If CAS# =  $V_{IH}$ , data output is High-Z.
11. If CAS# =  $V_{IL}$ , data output may contain data from the last valid READ cycle.
12. Measured with a load equivalent to two TTL gates,  $100pF$  and  $V_{OL} = 0.8V$  and  $V_{OH} = 2V$ .
13. If CAS# is LOW at the falling edge of RAS#, Q will be maintained from the previous cycle. To initiate a new cycle and clear the data-out buffer, CAS# must be pulsed HIGH for  $t_{CP}$ .
14. The  $t_{RCD}$  (MAX) limit is no longer specified.  $t_{RCD}$  (MAX) was specified as a reference point only. If  $t_{RCD}$  was greater than the specified  $t_{RCD}$  (MAX) limit, then access time was controlled exclusively by  $t_{CAC}$  ( $t_{RAC}$  [MIN] no longer applied). With or without the  $t_{RCD}$  limit,  $t_{AA}$  and  $t_{CAC}$  must always be met.
15. The  $t_{RAD}$  (MAX) limit is no longer specified.  $t_{RAD}$  (MAX) was specified as a reference point only. If  $t_{RAD}$  was greater than the specified  $t_{RAD}$  (MAX) limit, then access time was controlled exclusively by  $t_{AA}$  ( $t_{RAC}$  and  $t_{CAC}$  no longer applied). With or without the  $t_{RAD}$  (MAX) limit,  $t_{AA}$ ,  $t_{RAC}$ , and  $t_{CAC}$  must always be met.
16. Either  $t_{RCH}$  or  $t_{RRH}$  must be satisfied for a READ cycle.
17.  $t_{OFF}$  (MAX) defines the time at which the output achieves the open circuit condition and is not referenced to  $V_{OH}$  or  $V_{OL}$ .
18.  $t_{WCS}$ ,  $t_{RWD}$ ,  $t_{AWD}$ , and  $t_{CWD}$  are not restrictive operating parameters.  $t_{WCS}$  applies to EARLY WRITE cycles.  $t_{RWD}$ ,  $t_{AWD}$ , and  $t_{CWD}$  apply to READ-MODIFY-WRITE cycles. If  $t_{WCS} \geq t_{WCS}$  (MIN), the cycle is an EARLY WRITE cycle and the data output will remain an open circuit throughout the entire cycle. If  $t_{RWD} \geq t_{RWD}$  (MIN),  $t_{AWD} \geq t_{AWD}$  (MIN), and  $t_{CWD} \geq t_{CWD}$  (MIN), the cycle is a READ-MODIFY-WRITE and the data output will contain data read from the selected cell. If neither of the above conditions is met, the state of data-out is indeterminate. OE# held HIGH and WE# taken LOW after CAS# goes LOW result in a LATE WRITE (OE#-controlled) cycle.  $t_{WCS}$ ,  $t_{RWD}$ ,  $t_{CWD}$ , and  $t_{AWD}$  are not applicable in a LATE WRITE cycle.
19. These parameters are referenced to CAS# leading edge in EARLY WRITE cycles and WE# leading edge in LATE WRITE or READ-MODIFY-WRITE cycles.
20. If OE# is tied permanently LOW, LATE WRITE, or READ-MODIFY-WRITE operations are not permissible and should not be attempted.
21. A HIDDEN REFRESH may also be performed after a WRITE cycle. In this case, WE# = LOW and OE# = HIGH.
22. The 3ns minimum is a parameter guaranteed by design.
23. Column address changed once each cycle.
24.  $V_{IH}$  overshoot:  $V_{IH}$  (MAX) =  $V_{CC} + 2V$  for a pulse width  $\leq 10ns$ , and the pulse width cannot be greater than one third of the cycle rate.  $V_{IL}$  undershoot:  $V_{IL}$  (MIN) =  $-2V$  for a pulse width  $\leq 10ns$ , and the pulse width cannot be greater than one third of the cycle rate.

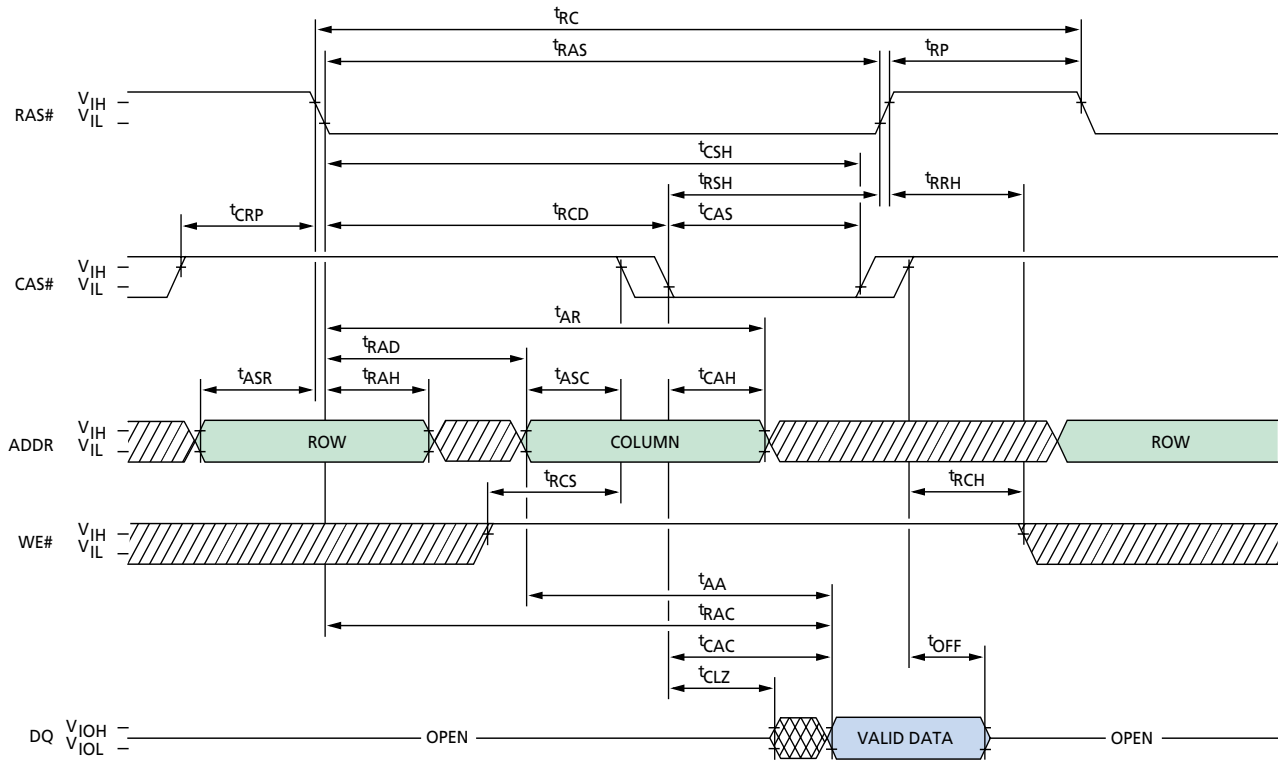

**READ CYCLE**

DON'T CARE  
 UNDEFINED

**TIMING PARAMETERS**

SYMBOL	-5		-6		UNITS
	MIN	MAX	MIN	MAX	
t <sub>AA</sub>		25		30	ns
t <sub>AR</sub>	38		45		ns
t <sub>ASC</sub>	0		0		ns
t <sub>ASR</sub>	0		0		ns
t <sub>CAC</sub>		13		15	ns
t <sub>CAH</sub>	8		10		ns
t <sub>CAS</sub>	8	10,000	10	10,000	ns
t <sub>CLZ</sub>	0		0		ns
t <sub>CRP</sub>	5		5		ns
t <sub>CSH</sub>	38		45		ns
t <sub>OD</sub>	0	12	0	15	ns
t <sub>OE</sub>		12		15	ns

SYMBOL	-5		-6		UNITS
	MIN	MAX	MIN	MAX	
t <sub>OFF</sub>	0	12	0	15	ns
t <sub>RAC</sub>		50		60	ns
t <sub>RAD</sub>	9		12		ns
t <sub>RAH</sub>	9		10		ns
t <sub>RAS</sub>	50	10,000	60	10,000	ns
t <sub>RC</sub>	84		104		ns
t <sub>RCD</sub>	11		14		ns
t <sub>RCH</sub>	0		0		ns
t <sub>RCS</sub>	0		0		ns
t <sub>RP</sub>	30		40		ns
t <sub>RRH</sub>	0		0		ns
t <sub>RSH</sub>	13		15		ns

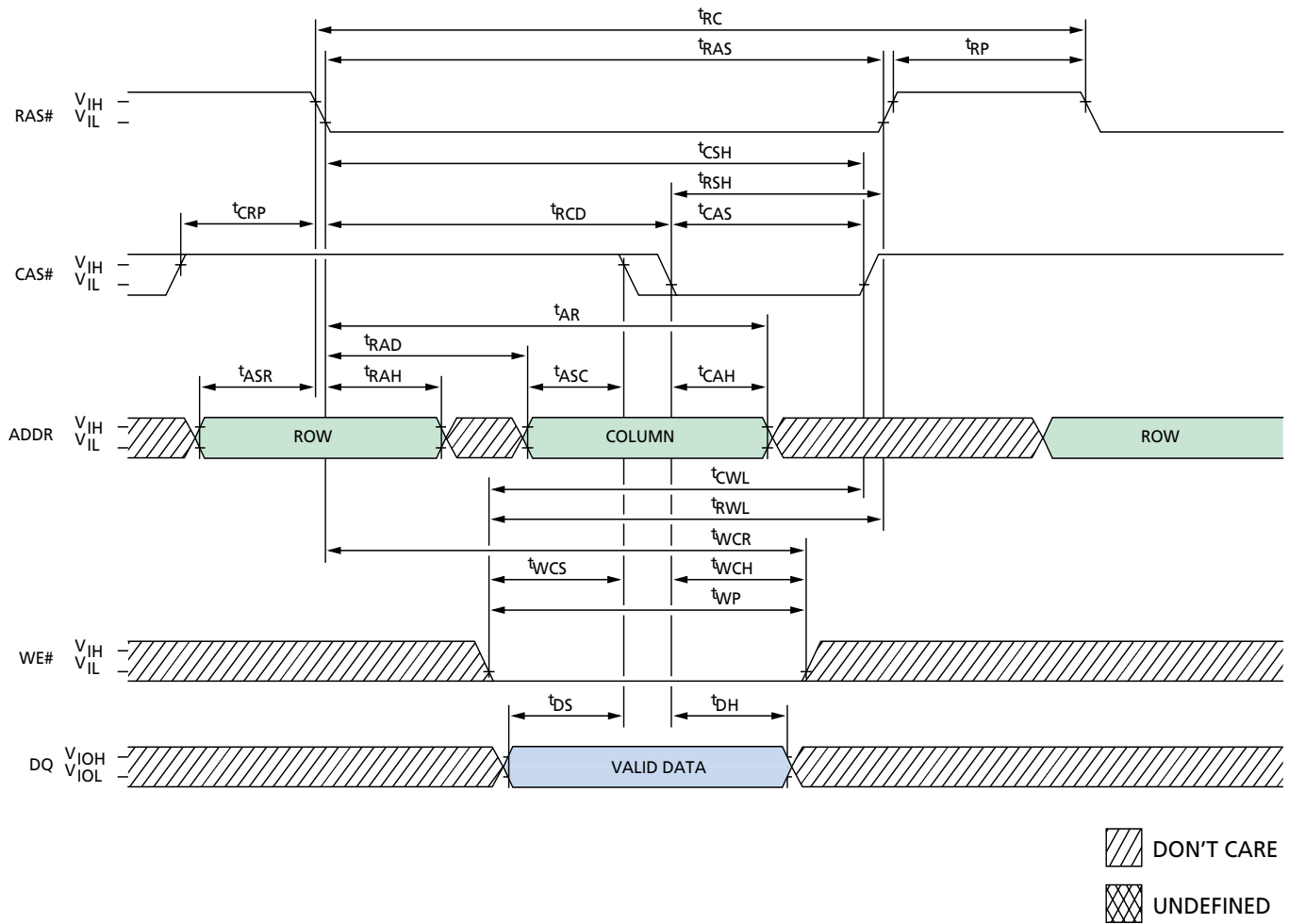
**EARLY WRITE CYCLE**

**TIMING PARAMETERS**

SYMBOL	-5		-6		UNITS
	MIN	MAX	MIN	MAX	
$t_{AR}$	38		45		ns
$t_{ASC}$	0		0		ns
$t_{ASR}$	0		0		ns
$t_{CAH}$	8		10		ns
$t_{CAS}$	8	10,000	10	10,000	ns
$t_{CRP}$	5		5		ns
$t_{CSH}$	38		45		ns
$t_{CWL}$	8		10		ns
$t_{DH}$	8		10		ns
$t_{DS}$	0		0		ns
$t_{RAD}$	9		12		ns

SYMBOL	-5		-6		UNITS
	MIN	MAX	MIN	MAX	
$t_{RAH}$	9		10		ns
$t_{RAS}$	50	10,000	60	10,000	ns
$t_{RC}$	84		104		ns
$t_{RCD}$	11		14		ns
$t_{RP}$	30		40		ns
$t_{RSH}$	13		15		ns
$t_{RWL}$	13		15		ns
$t_{WCH}$	8		10		ns
$t_{WCR}$	38		45		ns
$t_{WCS}$	0		0		ns
$t_{WP}$	5		5		ns

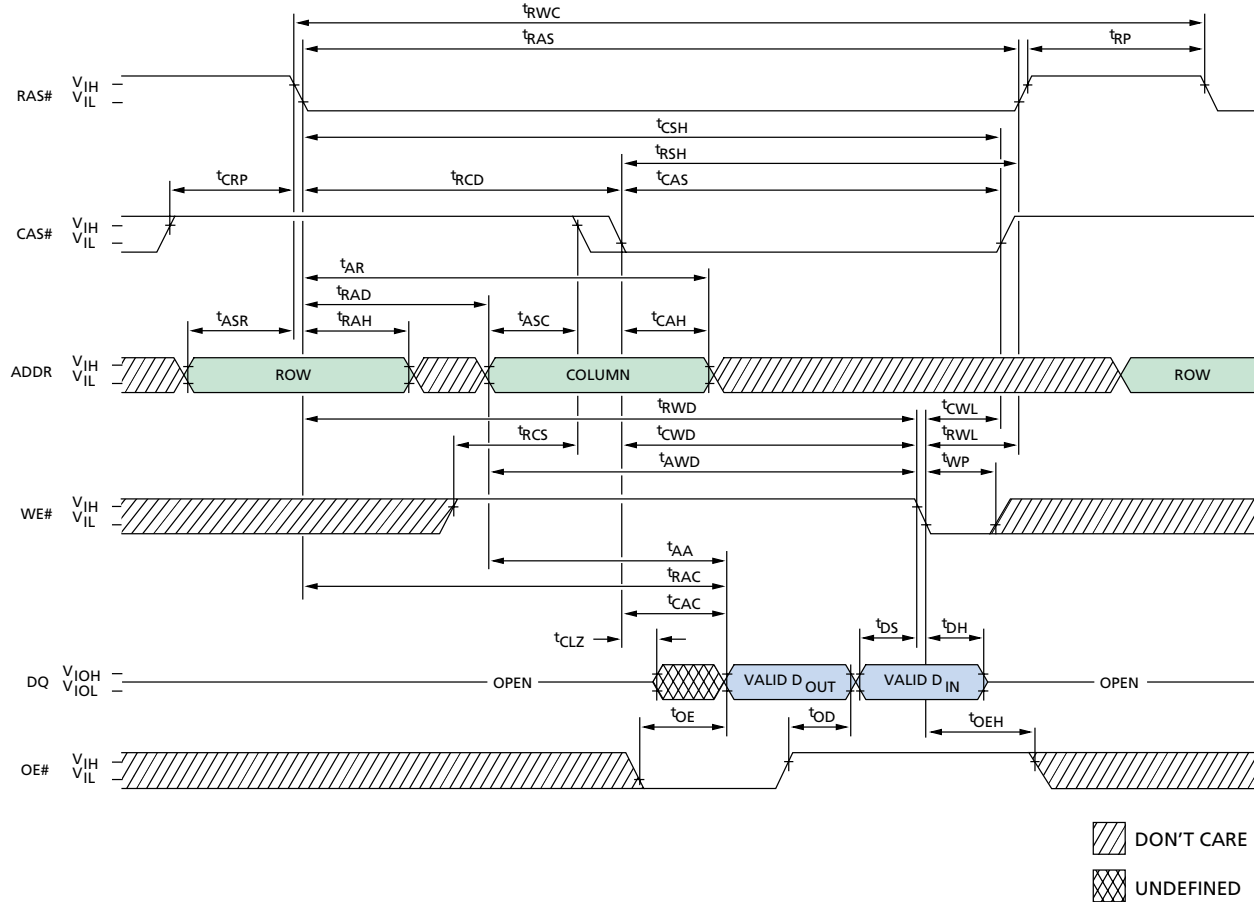
### READ-WRITE CYCLE (LATE WRITE and READ-MODIFY-WRITE cycles)



#### TIMING PARAMETERS

SYMBOL	-5		-6		UNITS
	MIN	MAX	MIN	MAX	
tAA		25		30	ns
tAR	38		45		ns
tASC	0		0		ns
tASR	0		0		ns
tAWD	42		49		ns
tCAC		13		15	ns
tCAH	8		10		ns
tCAS	8	10,000	10	10,000	ns
tCLZ	0		0		ns
tCRP	5		5		ns
tCSH	38		45		ns
tCWD	28		35		ns
tCWL	8		10		ns
tDH	8		10		ns
tDS	0		0		ns

SYMBOL	-5		-6		UNITS
	MIN	MAX	MIN	MAX	
tOD	0	12	0	15	ns
tOE		12		15	ns
tOEH	8		10		ns
tRAC		50		60	ns
tRAD	9		12		ns
tRAH	9		10		ns
tRAS	50	10,000	60	10,000	ns
tRCD	11		14		ns
tRCS	0		0		ns
tRP	30		40		ns
tRSH	13		15		ns
tRWC	116		140		ns
tRWD	67		79		ns
tRWL	13		15		ns
tWP	5		5		ns

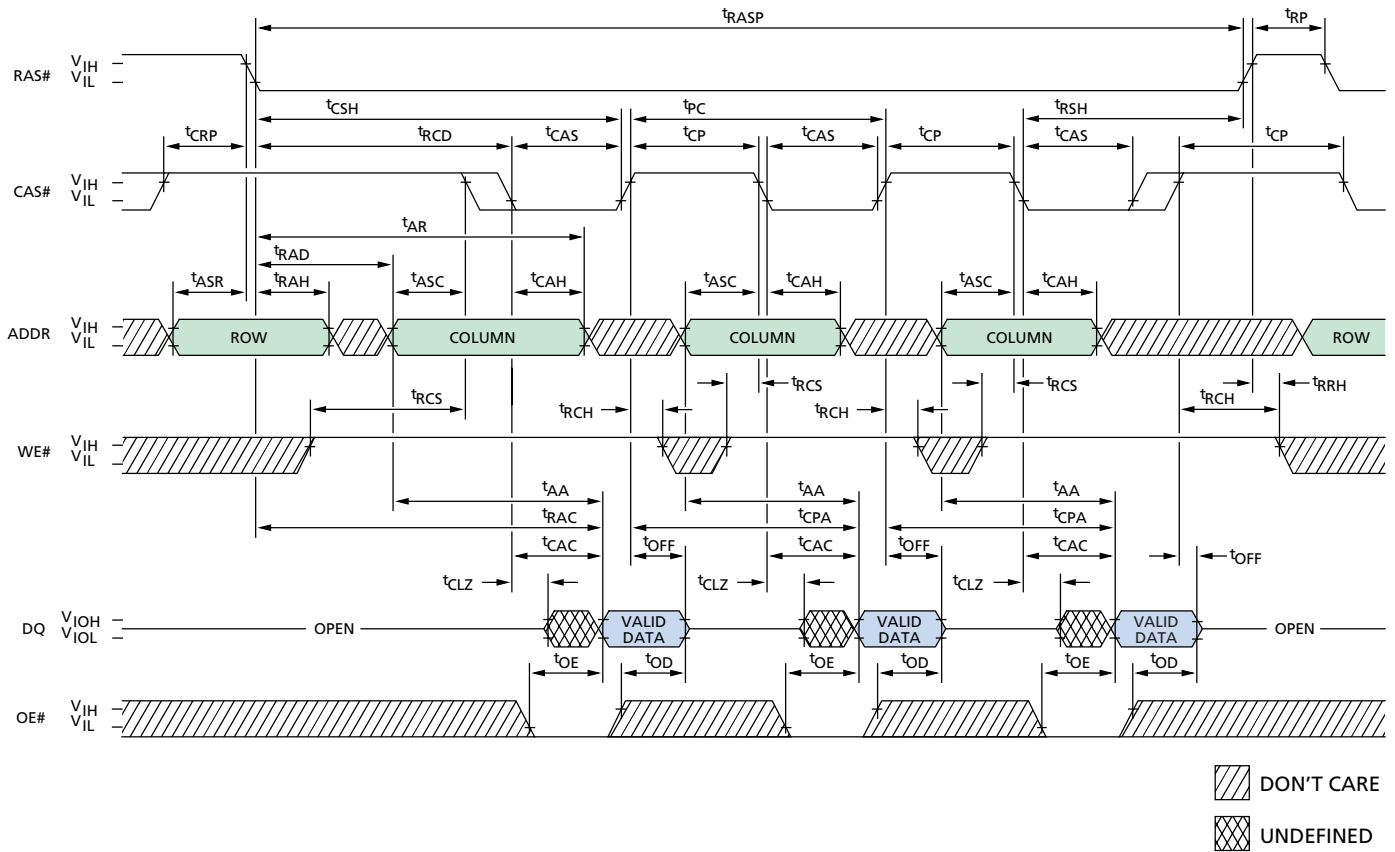
**FAST-PAGE-MODE READ CYCLE**

**TIMING PARAMETERS**

SYMBOL	-5		-6		UNITS
	MIN	MAX	MIN	MAX	
tAA		25		30	ns
tAR	38		45		ns
tASC	0		0		ns
tASR	0		0		ns
tCAC		13		15	ns
tCAH	8		10		ns
tCAS	8	10,000	10	10,000	ns
tCLZ	0		0		ns
tCP	8		10		ns
tCPA		28		35	ns
tCRP	5		5		ns
tCSH	38		45		ns
tOD	0	12	0	15	ns

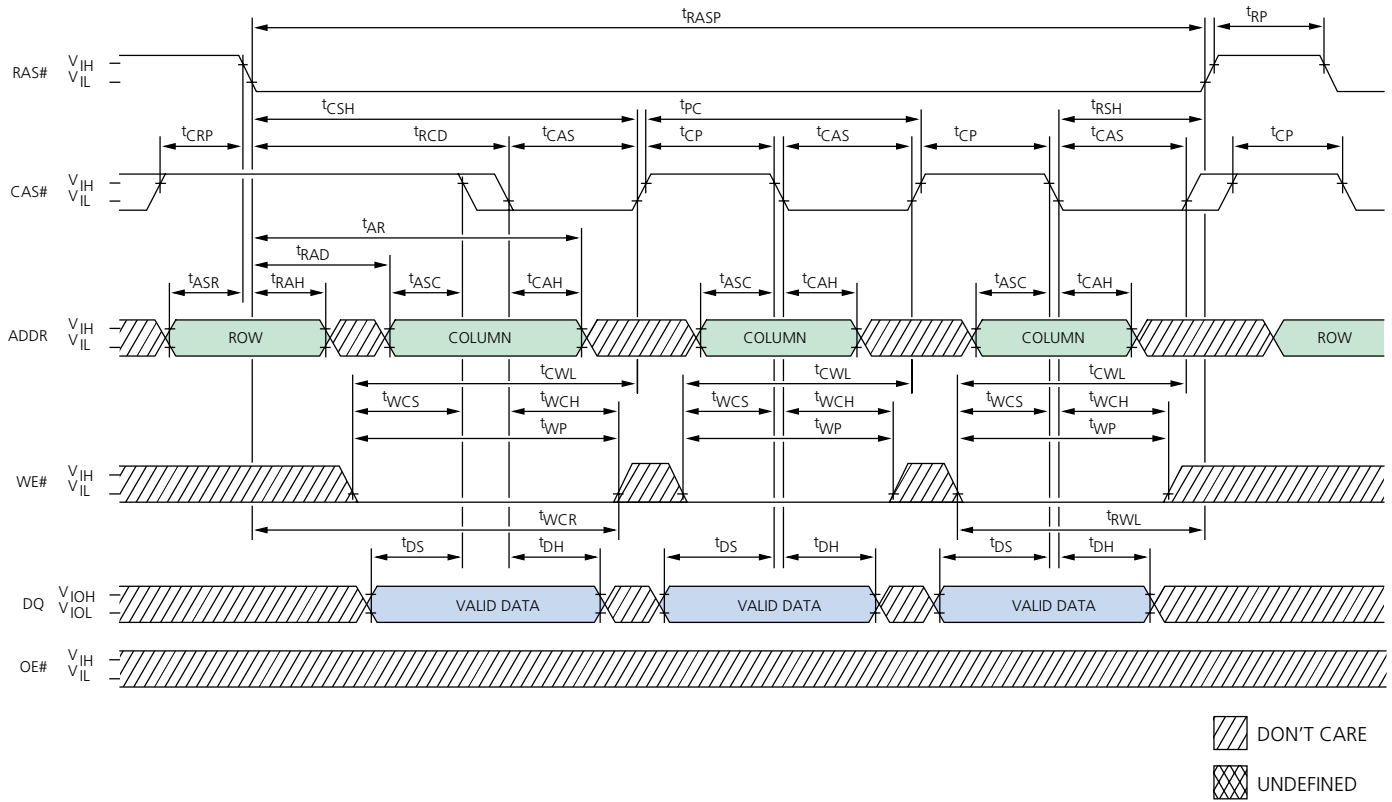
SYMBOL	-5		-6		UNITS
	MIN	MAX	MIN	MAX	
tOE		12		15	ns
tOFF	0	12	0	15	ns
tPC	20		25		ns
tRAC		50		60	ns
tRAD	9		12		ns
tRAH	9		10		ns
tRASP	50	125,000	60	125,000	ns
tRCD	11		14		ns
tRCH	0		0		ns
tRCS	0		0		ns
tRP	30		40		ns
tRRH	0		0		ns
tRSH	13		15		ns

**FAST-PAGE-MODE EARLY WRITE CYCLE**

**TIMING PARAMETERS**

SYMBOL	-5		-6		UNITS
	MIN	MAX	MIN	MAX	
t <sub>AR</sub>	38		45		ns
t <sub>ASC</sub>	0		0		ns
t <sub>ASR</sub>	0		0		ns
t <sub>CAH</sub>	8		10		ns
t <sub>CAS</sub>	8	10,000	10	10,000	ns
t <sub>CP</sub>	8		10		ns
t <sub>CRP</sub>	5		5		ns
t <sub>CSH</sub>	38		45		ns
t <sub>CWL</sub>	8		10		ns
t <sub>DH</sub>	8		10		ns
t <sub>DS</sub>	0		0		ns
t <sub>PC</sub>	20		25		ns

SYMBOL	-5		-6		UNITS
	MIN	MAX	MIN	MAX	
t <sub>RAD</sub>	9		12		ns
t <sub>RAH</sub>	9		10		ns
t <sub>RASP</sub>	50	125,000	60	125,000	ns
t <sub>RCD</sub>	11		14		ns
t <sub>RP</sub>	30		40		ns
t <sub>RSH</sub>	13		15		ns
t <sub>RWL</sub>	13		15		ns
t <sub>WCH</sub>	8		10		ns
t <sub>WCR</sub>	38		45		ns
t <sub>WCS</sub>	0		0		ns
t <sub>WP</sub>	5		5		ns

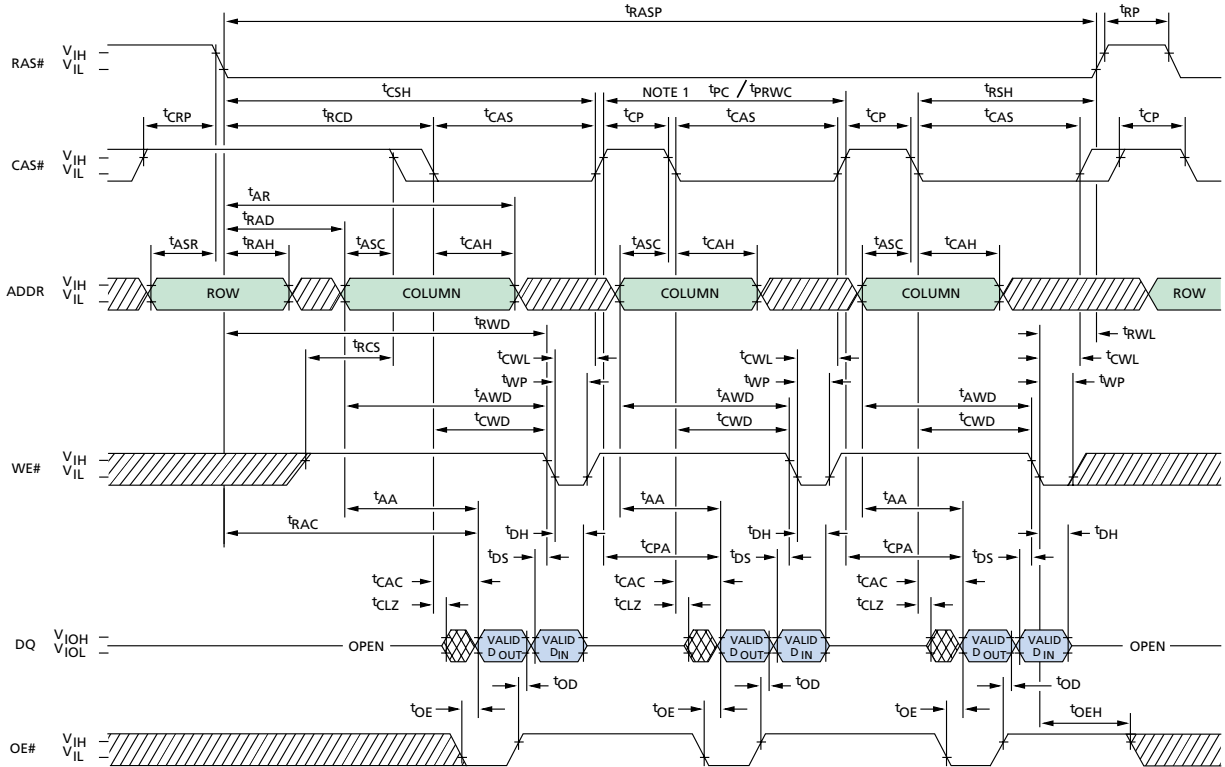
### FAST-PAGE-MODE READ-WRITE CYCLE (LATE WRITE and READ-MODIFY-WRITE cycles)



DON'T CARE  
 UNDEFINED

#### TIMING PARAMETERS

SYMBOL	-5		-6		UNITS
	MIN	MAX	MIN	MAX	
t <sub>AA</sub>		25		30	ns
t <sub>AR</sub>	38		45		ns
t <sub>ASC</sub>	0		0		ns
t <sub>ASR</sub>	0		0		ns
t <sub>AWD</sub>	42		49		ns
t <sub>CAC</sub>		13		15	ns
t <sub>CAH</sub>	8		10		ns
t <sub>CAS</sub>	8	10,000	10	10,000	ns
t <sub>CLZ</sub>	0		0		ns
t <sub>CP</sub>	8		10		ns
t <sub>CPA</sub>		28		35	ns
t <sub>CRP</sub>	5		5		ns
t <sub>CSH</sub>	38		45		ns
t <sub>CWD</sub>	28		35		ns
t <sub>CWL</sub>	8		10		ns
t <sub>DH</sub>	8		10		ns
t <sub>DS</sub>	0		0		ns

SYMBOL	-5		-6		UNITS
	MIN	MAX	MIN	MAX	
t <sub>OD</sub>	0	12	0	15	ns
t <sub>OE</sub>		12		15	ns
t <sub>OEHL</sub>	8		10		ns
t <sub>PC</sub>	20		25		ns
t <sub>PRWC</sub>	47		56		ns
t <sub>RAC</sub>		50		60	ns
t <sub>RAD</sub>	9		12		ns
t <sub>RAH</sub>	9		10		ns
t <sub>RASP</sub>	50	125,000	60	125,000	ns
t <sub>RCD</sub>	11		14		ns
t <sub>RCS</sub>	0		0		ns
t <sub>RP</sub>	30		40		ns
t <sub>RSH</sub>	13		15		ns
t <sub>RWD</sub>	67		79		ns
t <sub>RWL</sub>	13		15		ns
t <sub>WPL</sub>	5		5		ns

**NOTE:** 1. t<sub>PC</sub> is for LATE WRITE only.

### FAST-PAGE-MODE READ EARLY WRITE CYCLE (Pseudo READ-MODIFY-WRITE)

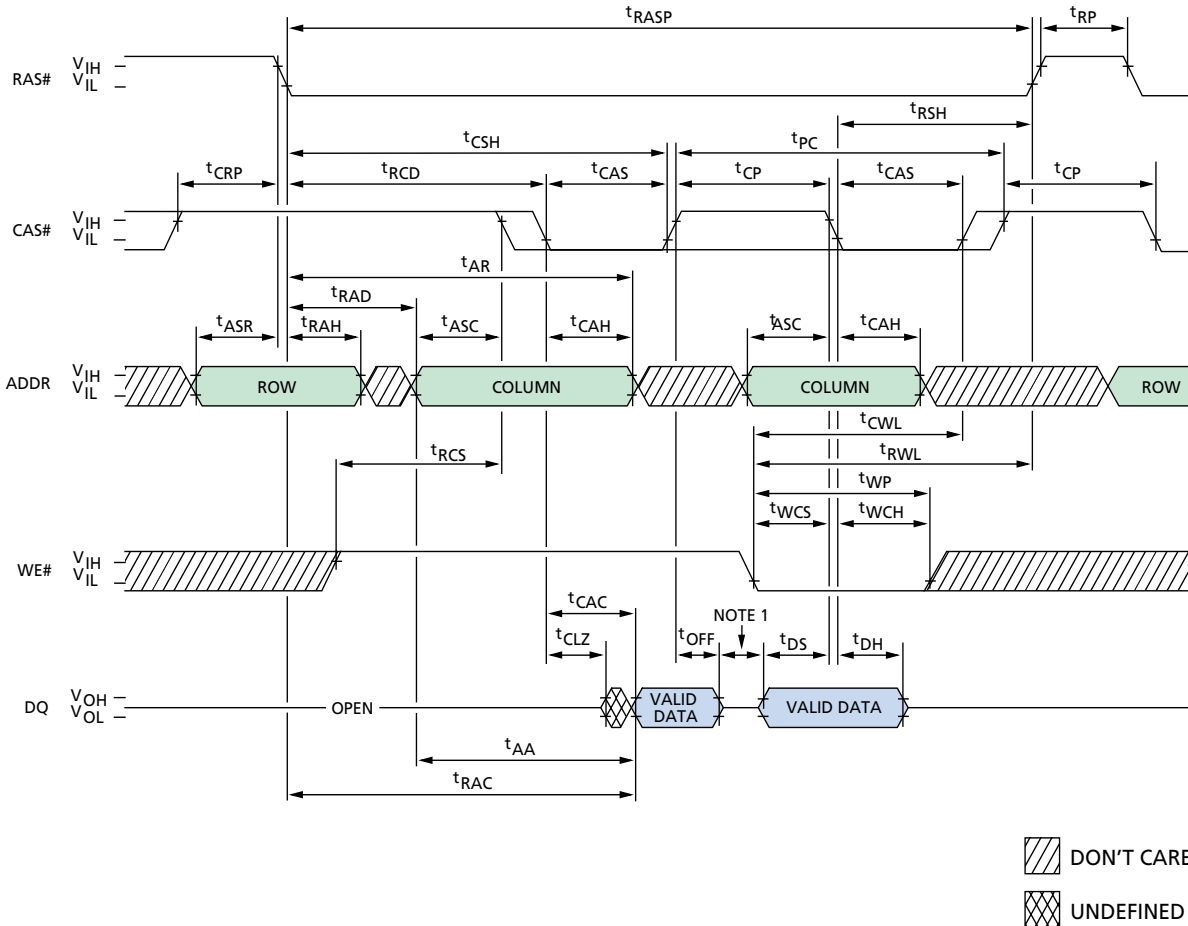

### TIMING PARAMETERS

SYMBOL	-5		-6		UNITS
	MIN	MAX	MIN	MAX	
$t_{AA}$		25		30	ns
$t_{AR}$	38		45		ns
$t_{ASC}$	0		0		ns
$t_{ASR}$	0		0		ns
$t_{CAC}$		13		15	ns
$t_{CAH}$	8		10		ns
$t_{CAS}$	8	10,000	10	10,000	ns
$t_{CLZ}$	0		0		ns
$t_{CP}$	8		10		ns
$t_{CRP}$	5		5		ns
$t_{CSH}$	38		45		ns
$t_{CWL}$	8		10		ns
$t_{DH}$	8		10		ns
$t_{DS}$	0		0		ns

SYMBOL	-5		-6		UNITS
	MIN	MAX	MIN	MAX	
$t_{OFF}$	0	12	0	15	ns
$t_{PC}$	20		25		ns
$t_{RAC}$		50		60	ns
$t_{RAD}$	9		12		ns
$t_{RAH}$	9		10		ns
$t_{RASP}$	50	125,000	60	125,000	ns
$t_{RCD}$	11		14		ns
$t_{RCS}$	0		0		ns
$t_{RP}$	30		40		ns
$t_{RSH}$	13		15		ns
$t_{RWL}$	13		15		ns
$t_{WCH}$	8		10		ns
$t_{WCS}$	0		0		ns
$t_{WP}$	5		5		ns

**NOTE:** 1. Do not drive data prior to tristate.



### RAS#-ONLY REFRESH CYCLE (OE# and WE# = DON'T CARE)

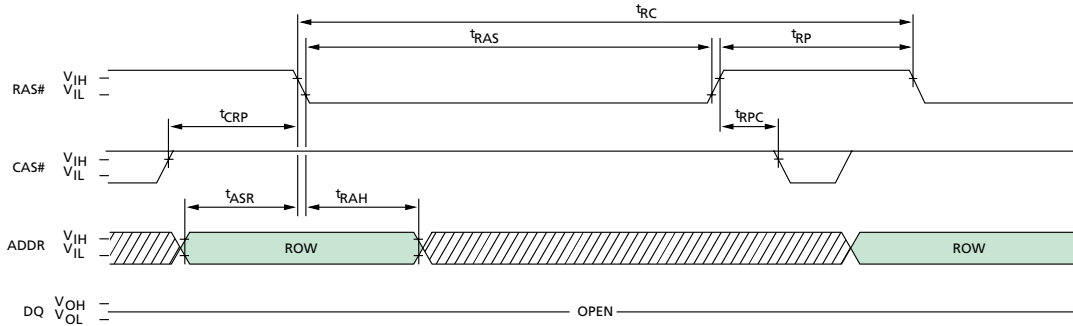

### CBR REFRESH CYCLE (Addresses and OE# = DON'T CARE)

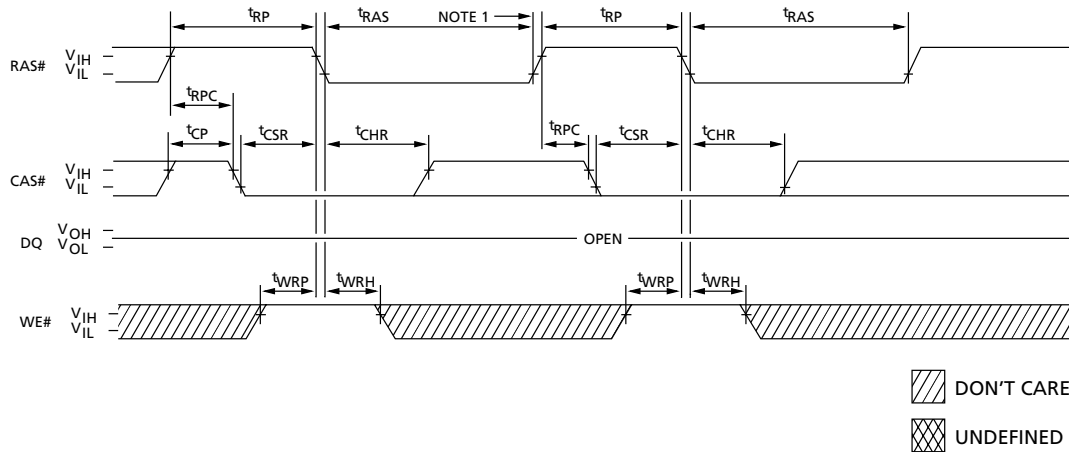

### TIMING PARAMETERS

SYMBOL	-5		-6		UNITS
	MIN	MAX	MIN	MAX	
$t_{ASR}$	0		0		ns
$t_{CHR}$	8		10		ns
$t_{CP}$	8		10		ns
$t_{CRP}$	5		5		ns
$t_{CSR}$	5		5		ns
$t_{RAH}$	9		10		ns

SYMBOL	-5		-6		UNITS
	MIN	MAX	MIN	MAX	
$t_{RAS}$	50	10,000	60	10,000	ns
$t_{RC}$	84		104		ns
$t_{RP}$	30		40		ns
$t_{RPC}$	5		5		ns
$t_{WRH}$	8		10		ns
$t_{WRP}$	8		10		ns

**NOTE:** 1. End of CBR REFRESH cycle.

### HIDDEN REFRESH CYCLE <sup>1</sup> (WE# = HIGH; OE# = LOW)

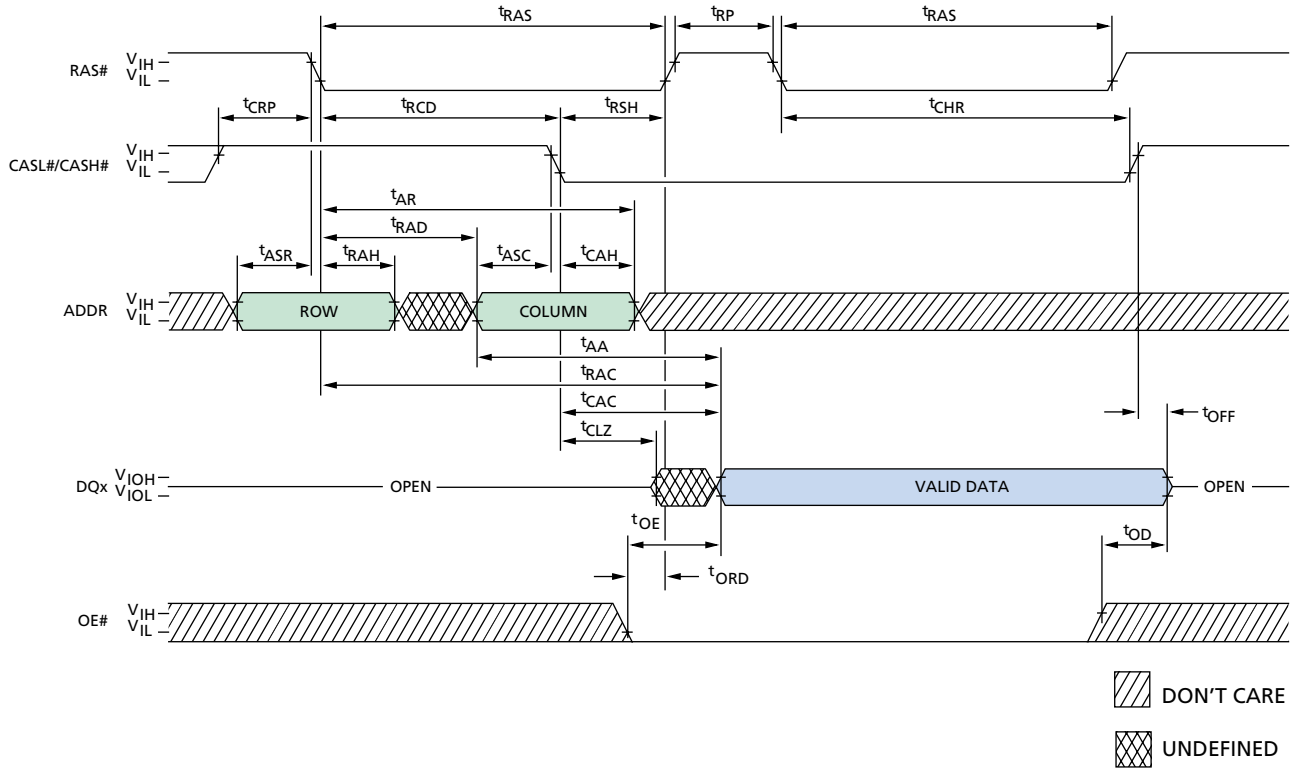

**TIMING PARAMETERS**

SYMBOL	-5		-6		UNITS
	MIN	MAX	MIN	MAX	
t <sub>AA</sub>		25		30	ns
t <sub>AR</sub>	38		45		ns
t <sub>ASC</sub>	0		0		ns
t <sub>ASR</sub>	0		0		ns
t <sub>CAC</sub>		13		15	ns
t <sub>CAH</sub>	8		10		ns
t <sub>CHR</sub>	8		10		ns
t <sub>CLZ</sub>	0		0		ns
t <sub>CRP</sub>	5		5		ns
t <sub>OD</sub>	0	12	0	15	ns

SYMBOL	-5		-6		UNITS
	MIN	MAX	MIN	MAX	
t <sub>OE</sub>		12		15	ns
t <sub>OFF</sub>	0	12	0	15	ns
t <sub>ORD</sub>	0		0		ns
t <sub>RAC</sub>		50		60	ns
t <sub>RAD</sub>	9		12		ns
t <sub>RAH</sub>	9		10		ns
t <sub>RAS</sub>	50	10,000	60	10,000	ns
t <sub>RCD</sub>	11		14		ns
t <sub>RP</sub>	30		40		ns
t <sub>RSH</sub>	13		15		ns

**NOTE:** 1. A HIDDEN REFRESH may also be performed after a WRITE cycle. In this case, WE# is LOW and OE# is HIGH.

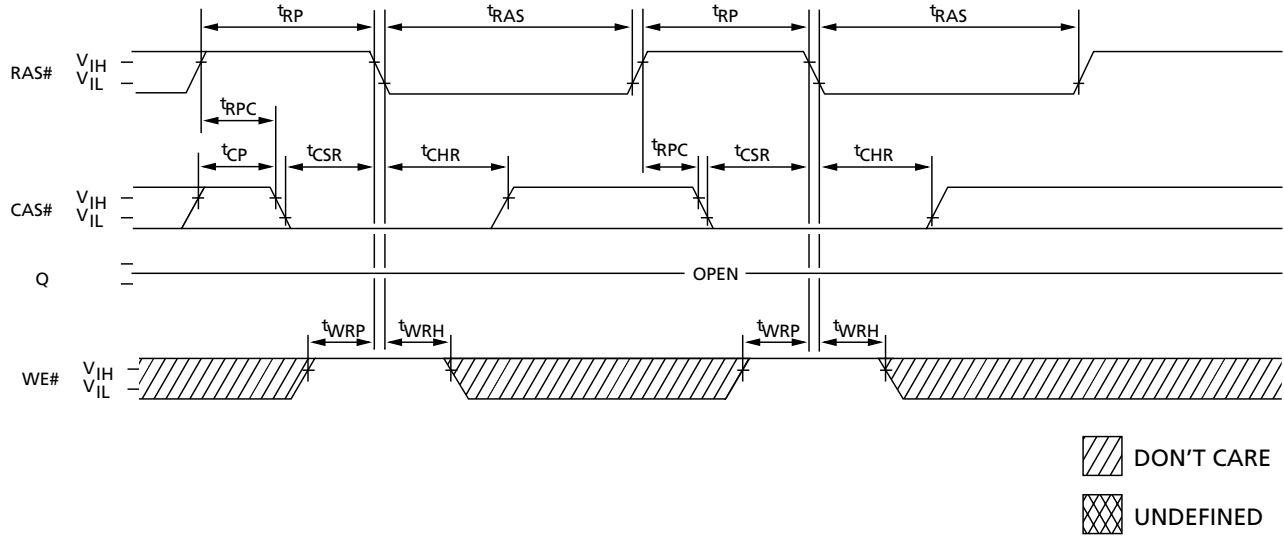
### SELF REFRESH CYCLE (Addresses and OE# = DON'T CARE)



### TIMING PARAMETERS

SYMBOL	-5		-6		UNITS
	MIN	MAX	MIN	MAX	
$t_{CHD}$	15		15		ns
$t_{CP}$	8		10		ns
$t_{CSR}$	5		5		ns
$t_{RASS}$	100		100		$\mu$ s
$t_{RP}$	30		40		ns

SYMBOL	-5		-6		UNITS
	MIN	MAX	MIN	MAX	
$t_{RPC}$	5		5		ns
$t_{RPS}$	90		105		ns
$t_{WRH}$	8		10		ns
$t_{WRP}$	8		10		ns

- NOTE:**
- Once  $t_{RASS}$  (MIN) is met and RAS# remains LOW, the DRAM will enter self refresh mode.
  - Once  $t_{RPS}$  is satisfied, a complete burst of all rows should be executed if RAS#-only or burst CBR refresh is used.

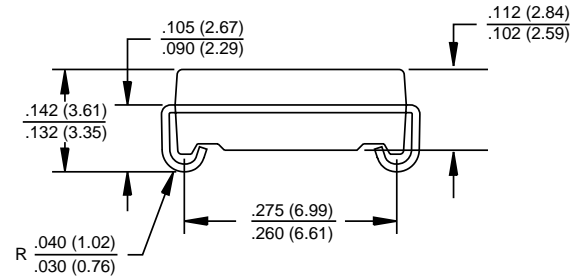
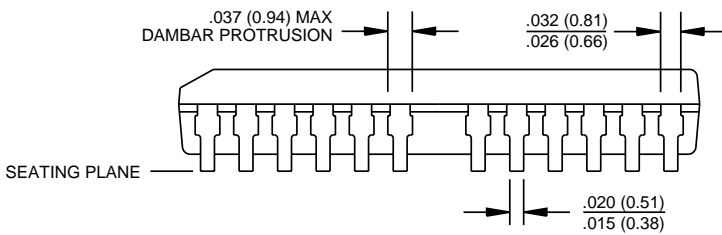
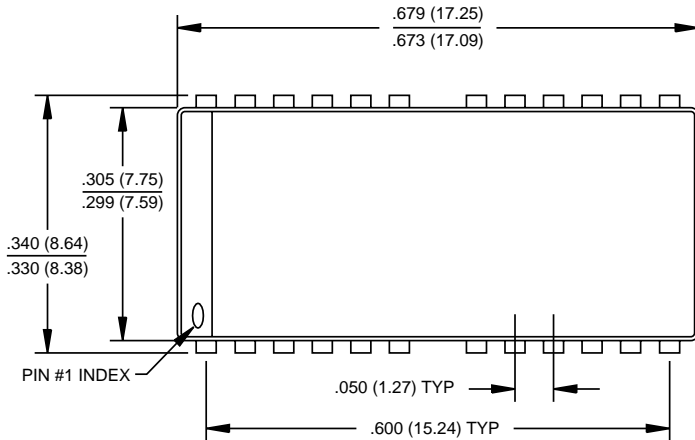
**24/26-PIN PLASTIC SOJ (300 mil)**

- NOTE:**
1. All dimensions in inches (millimeters)  $\frac{\text{MAX}}{\text{MIN}}$  or typical where noted.
  2. Package width and length do not include mold protrusion; allowable mold protrusion is .01" per side.

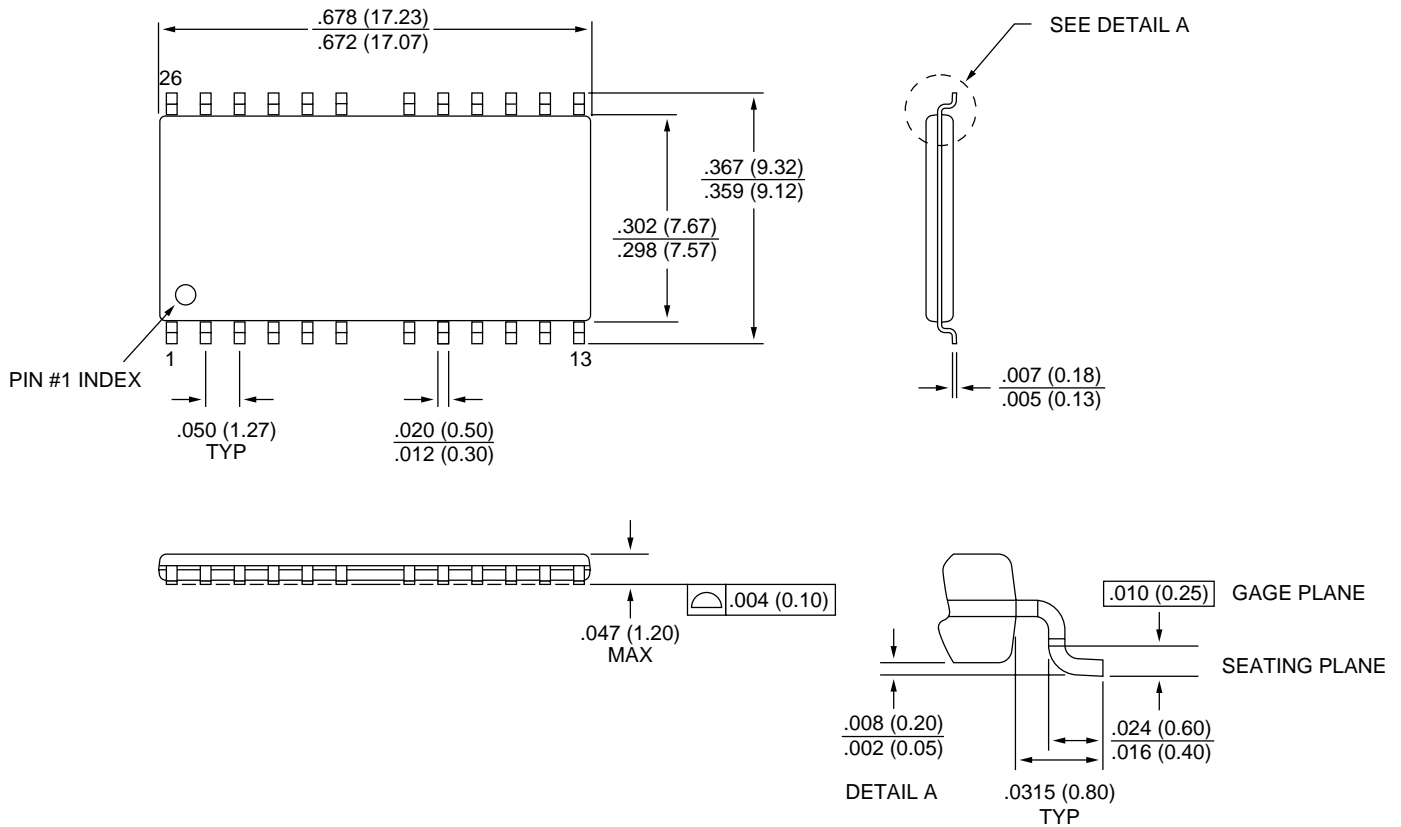
**24/26-PIN PLASTIC TSOP (300 mil)**

- NOTE:**
1. All dimensions in inches (millimeters)  $\frac{\text{MAX}}{\text{MIN}}$  or typical where noted.
  2. Package width and length do not include mold protrusion; allowable mold protrusion is .01" per side.



8000 S. Federal Way, P.O. Box 6, Boise, ID 83707-0006, Tel: 208-368-3900

E-mail: [prodmtg@micron.com](mailto:prodmtg@micron.com), Internet: <http://www.micron.com>, Customer Comment Line: 800-932-4992

Micron is a registered trademark of Micron Technology, Inc.