

16Gb NAND Flash H27UAG8T2B

Document Title
16Gbit (2048 M x 8 bit) NAND Flash Memory

Revision History

Revision No.	History	Draft Date	Remark
0.0	Initial Draft.	Feb. 25. 2010	Preliminary
0.1	Draft version Release	Mar. 08. 2010	Preliminary
1.0	Final version Release Spec. change : tWHR (before : 80ns min / after : 100ns min)	Aug. 06. 2010	Release



■ **Multilevel Cell technology**

■ **Supply Voltage**

- 3.3V device : Vcc = 2.7 V ~ 3.6 V
Vcc = 2.7 V ~ 3.6 V

■ **Organization**

- Page size : 8,640 Bytes(8,192+448 bytes)
- Block size : 256 pages(2M+112K bytes)
- Plane size : 512 blocks

■ **Page Read Time**

- Random Access: 200 μ s (Max.)
- Sequential Access : 25 ns (Min.)

■ **Write Time**

- Page program : 1600 μ s (Typ.)
- Block erase : 2.5 ms (Typ.)

■ **Operating Current**

- Read
- Program
- Erase
- Standby

■ **Hardware Data Protection**

- Program/Erase locked during power transitions

■ **Endurance**

- 3,000 P/E cycles (with 24 bit/ 1,024byte ECC)

■ **Data Retention**

- 10 Years

■ **Package**

- TSOP (12x20), 48Pin
- Wafer (Bare Die)

■ **Unique ID for copyright protection**

1. SUMMARY DESCRIPTION

1. SUMMARY DESCRIPTION

The H27UAG8T2B is a single 3.3V 16Gbit NAND flash memory. The Device contains 2 planes in a single die. Each plane is made up of the 512 blocks. Each block consists of 256 programmable pages. Each page contains 8,640 bytes. The pages are subdivided into an 8,192-bytes main data storage area with a spare 448-byte district.

Page program operation can be performed in typical 1,600us, and a single block can be erased in typical 2.5ms. On-chip control logic unit automates erase and program operations to maximize cycle endurance. E/W endurance is stipulated at 3,000 cycles when using relevant ECC and Error management.

The H27UAG8T2B is a best solution for applications requiring large nonvolatile storage memory.

1.1. Product List

Table 1

PART NUMBER	ORGANIZATION	Vcc RANGE	PACKAGE
H27UAG8T2B	X8	2.7V ~ 3.6V	48 - TSOP1

1.2. Packaging Information

■ Figure 1. 48-TSOP1 Contact, x8 Device

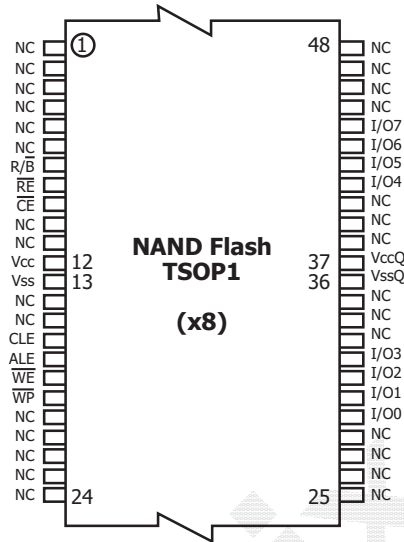

■ Figure 1-1. 48-TSOP1 - 48-lead Plastic Thin Small Outline, 12 x 20mm, Package Outline

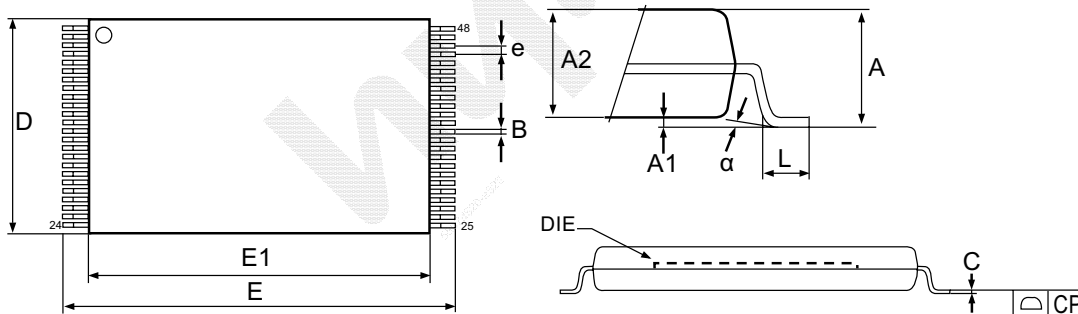

Symbol	millimeters		
	Min	Typ	Max
A			1.200
A1	0.050		0.150
A2	0.980		1.030
B	0.170		0.250
C	0.100		0.200
CP			0.100
D	11.910	12.000	12.120
E	19.900	20.000	20.100

Symbol	millimeters		
	Min	Typ	Max
E1	18.300	18.400	18.500
e		0.500	
L	0.500		0.680
alpha	0		5

48-TSOP1 - 48-lead Plastic Thin Small Outline, 12 x 20mm, Package Mechanical Data

Pin Diagram

■ Figure 2. Pin Diagram

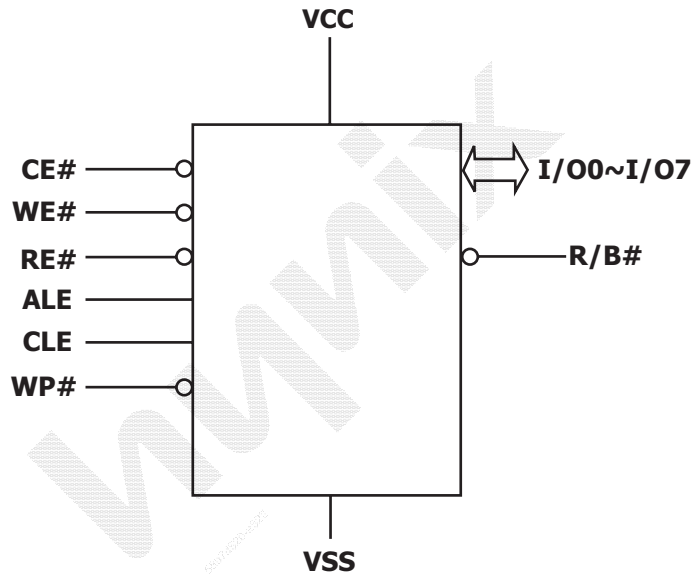

Pin Names

I/O7~I/O0	Data Input / Outputs
CLE	Command Latch Enable
ALE	Address Latch Enable
CE#	Chip Enable
RE#	Read Enable
R/B#	Ready / Busy
WE#	Write Enable
WP#	Write Protect
VCC	Power Supply
VSS	Ground
NC	No Connection

1.3. PIN DESCRIPTION

Pin Name	Description
I/O0-I/O7	DATA INPUTS/OUTPUTS The I/O pins are used to COMMAND LATCH cycle, ADDRESS INPUT cycle, and DATA in-out cycles during read / write operations. The I/O pins float to High-Z when the device is deselected or the outputs are disabled.
CLE	COMMAND LATCH ENABLE This input activates the latching of the I/O inputs inside the Command Register on the Rising edge of Write Enable (WE#).
ALE	ADDRESS LATCH ENABLE This input activates the latching of the I/O inputs inside the Address Register on the Rising edge of Write Enable (WE#).
CE#	CHIP ENABLE This input controls the selection of the device. When the device is busy, CE# low does not deselect the memory. The device goes into Stand-by mode when CE# goes High during 10us in Ready state. The CE# signal is ignored when device is in Busy state, and will not enter Standby mode even if the CE# goes high.
WE#	WRITE ENABLE This input acts as clock to latch Command, Address and Data. The I/O inputs are latched on the rise edge of WE#.
RE#	READ ENABLE The RE# input is the serial data-out control, and when active drives the data onto the I/O bus. Data is valid tREA after the falling edge of RE# which also increments the internal column address counter by one.
WP#	WRITE PROTECT The WP# pin, when Low, provides a hardware protection against undesired write operations. Hardware Write Protection is activated when the Write Protect pin is low. In this condition modify operation do not start and the content of the memory is not altered. Write Protect pin is not latched by Write Enable to ensure the protection even during the power up phases.
R/B#	READY / BUSY The Ready/Busy output is an Open Drain pin that signals the state of the memory.
Vcc	SUPPLY VOLTAGE The VCC supplies the power for all the operations. (Read, Write, and Erase).
Vss	GROUND
NC	NO CONNECTED

Notes:

A 0.1uF capacitor should be connected between the Vcc Supply Voltage pin and the Vss Ground pin to decouple the current surges from the power supply. The PCB track widths must be sufficient to carry the currents required during program and erase operations.

1.4. Block Diagram

■ Figure 3. Block diagram

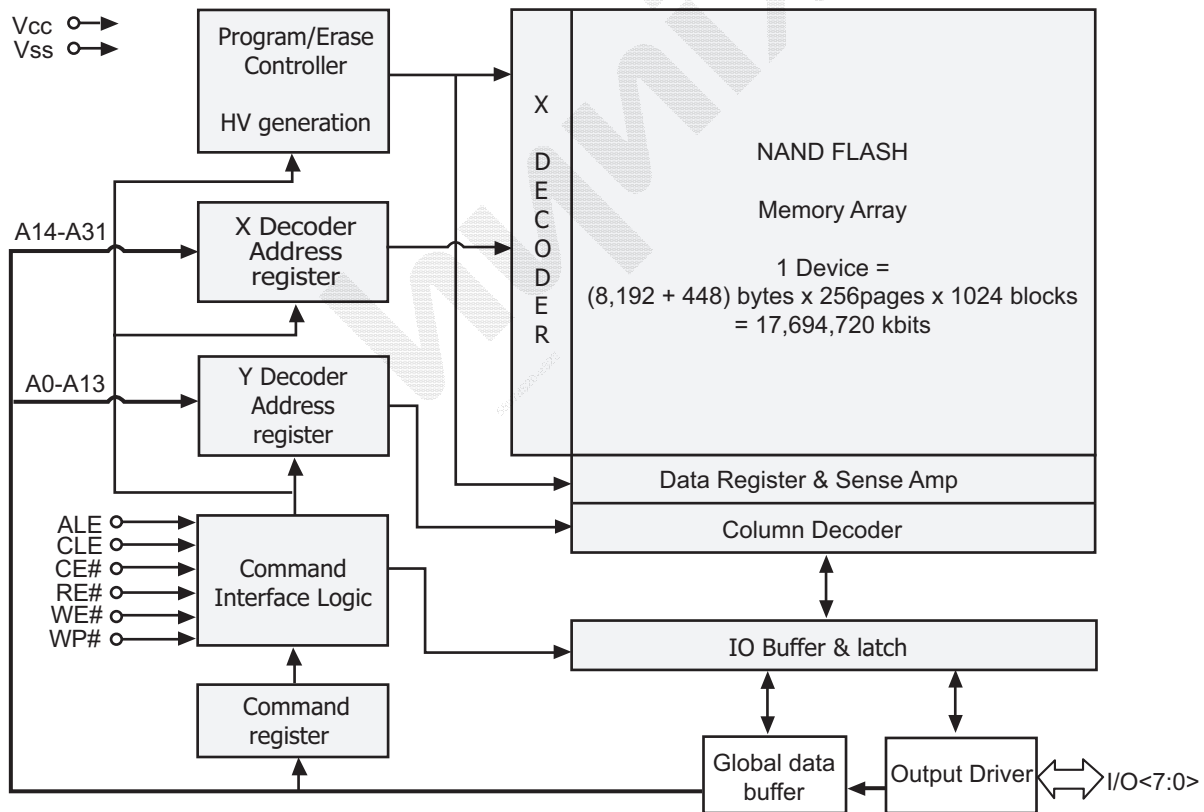

1.5. Array Organization

■ Figure 4. Array organization

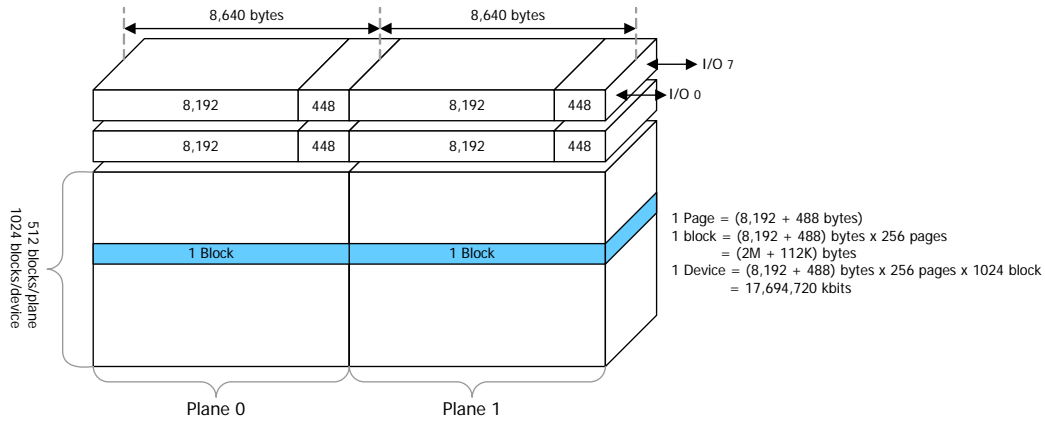

1.6. Addressing

Bus cycle	I/O0	I/O1	I/O2	I/O3	I/O4	I/O5	I/O6	I/O7
1 st Cycle	A0	A1	A2	A3	A4	A5	A6	A7
2 nd Cycle	A8	A9	A10	A11	A12	A13	L ⁽¹⁾	L ⁽¹⁾
3 rd Cycle	A14	A15	A16	A17	A18	A19	A20	A21
4 th Cycle	A22	A23	A24	A25	A26	A27	A28	A29
5 th Cycle	A30	A31	L ⁽¹⁾	L ⁽¹⁾	L ⁽¹⁾	L ⁽¹⁾	L ⁽¹⁾	L ⁽¹⁾

Notes:

1. L must be set to Low.
2. The device ignores any additional address input cycle than required.
3. The Address consists of column address (A0~A13), page address (A14 ~ A21), plane address (A22), and block address (A23 ~ the last address).

1.7. Command Set

FUNCTION	1st Cycle	Number of Address cycles	Data input cycles	2nd Cycle	Number of Address cycles	Data input cycles	3rd Cycle	Acceptable command during busy
PAGE READ	00h	5	-	30h	-	-	-	No
READ FOR COPY-BACK	00h	5	-	35h	-	-	-	No
RANDOM DATA OUTPUT ¹⁾	05h	2	-	E0h	-	-	-	No
SINGLE/multi plane CACHE READ ⁵⁾	31h	-	-	-	-	-	-	No
SINGLE/multi plane CACHE READ END ⁵⁾	3Fh	-	-	-	-	-	-	No
READ ID	90h	1	-	-	-	-	-	No
READ STATUS REGISTER	70h	-	-	-	-	-	-	Yes
PAGE PGM (start) / CACHE PGM ⁵⁾ (end)	80h	5	Yes	10h	-	-	-	No
RANDOM DATA INPUT ¹⁾	85h	2	Yes	-	-	-	-	No
COPY-BACK PGM	85h	5	option	10h	-	-	-	No
CACHE PGM (start) ⁵⁾	80h	5	Yes	15h	-	-	-	No
BLOCK ERASE	60h	3	-	D0h	-	-	-	No
RESET	FFh	-	-	-	-	-	-	Yes
multi plane PAGE READ	60h	3	-	60h	3	-	30h	No
multi plane CACHE READ START ⁵⁾	60h	3	-	60h	3	-	30h/ 33h	No
multi plane READ FOR COPY-BACK	60h	3	-	60h	3	-	35h	No
multi plane BLOCK ERASE	60h	3	-	60h	3	-	D0h	No
multi plane DATA OUTPUT ^{1) 3)}	00h	5	-	05h	2	-	E0h	No
multi plane READ STATUS REGISTER	78h	3	-	-	-	-	-	Yes
multi plane PAGE PGM / multi plane CACHE PGM (end)	80h	5	Yes	11h~81h ²⁾	5	Yes	10h	No
multi plane COPY-BACK PGM	85h	5	option	11h~81h ²⁾	5	option	10h	No
multi plane CACHE PGM (start) ⁵⁾	80h	5	Yes	11h~81h ²⁾	5	Yes	15h	No
User OTP ENTRY COMMAND	04h			19h				No
Unique ID READ ENTRY COMMAND	02h			19h				No
Unique ID PGM ENTRY COMMAND	84h			97h			08h	No
READ ID2 ENTRY COMMAND	30h			65h				No





Notes:

1. Random Data Input/Output must be performed in a selected page.
2. Any command between 11h and 81h is prohibited except 70h, 78h, and FFh.
3. Multi Plane Random data-out must be used after Multi Plane read operations (Multi Plane Page Read, Multi Plane Cache Read and Multi Plane Read for Copy Back).
4. Do not change Plane address order when using all Multi Plane operations.
5. All cache operation (cache program, cache read) is available only within a block.
6. Interleave operation between two chips are allowed. Multi Plane Read Status (78h) can be used to check each chip status. It is prohibited to use Read Status command (70h) in interleaved operation.

Caution:

1. Any undefined command inputs are prohibited except for above command set.
2. Multi Plane page read, Multi Plane cache read, and Multi Plane read for copy-back must be used after Multi Plane programmed page, Multi Plane cache program, and Multi Plane copy-back program.

1.8. Mode Selection

CLE	ALE	CE#	WE#	RE#	WP#	MODE	
H	L	L		H	X	Read Mode	Command Input
L	H	L		H	X		Address Input (5 Cycles)
H	L	L		H	H	Write Mode	Command Input
L	H ¹⁾	L		H	H		Address Input (5 Cycles)
L	L	L		H	H	Data Input	
L	L ¹⁾	L	H		X	Sequential Read and Data Output	
X	X	X	H ³⁾	H ³⁾	X	During Read (Busy)	
X	X ¹⁾	X	X	X	H	During Program (Busy)	
X	X	X	X	X	H	During Erase (Busy)	
X	X	X	X	X	L	Write Protect	
X	X	H	X	X	0V/Vcc ²⁾	Stand-By	

Notes:

1. X can be VIL or VIH. H = Logic level HIGH. L = Logic level LOW.
2. WP# should be biased to CMOS high or CMOS low for stand-by mode.
3. WE# and RE# during Read Busy must be keep on high to prevent unplanned command/address/data input or to avert unintended data out. In this time, only Reset, Read Status, and Multi Plane Read Status can be inputted to the device.

1.9. Bad Block Management

Devices with Bad Blocks have the same quality level and the same AC and DC characteristics as devices where all the blocks are valid. A Bad Block does not affect the performance of valid blocks because it is isolated from the bit line and common source line by a select transistor. The devices are supplied with all the locations inside valid blocks erased (FFh). The Bad Block Information is written prior to shipping. Any block where the 1st Byte in the spare area of either the 1st or the last page does not contain FFh is a Bad Block. The Bad Block Information must be read before any erase is attempted as the Bad Block Information may be erased. For the system to be able to recognize the Bad Blocks based on the original information it is recommended to create a Bad Block table following the flowchart shown in Flow chart 1 (*Bad block management flow chart*). The 1st block, which is placed on 00h block address, is guaranteed to be a valid block at the time of shipment.

■ Flow chart 1. Bad block management flow chart

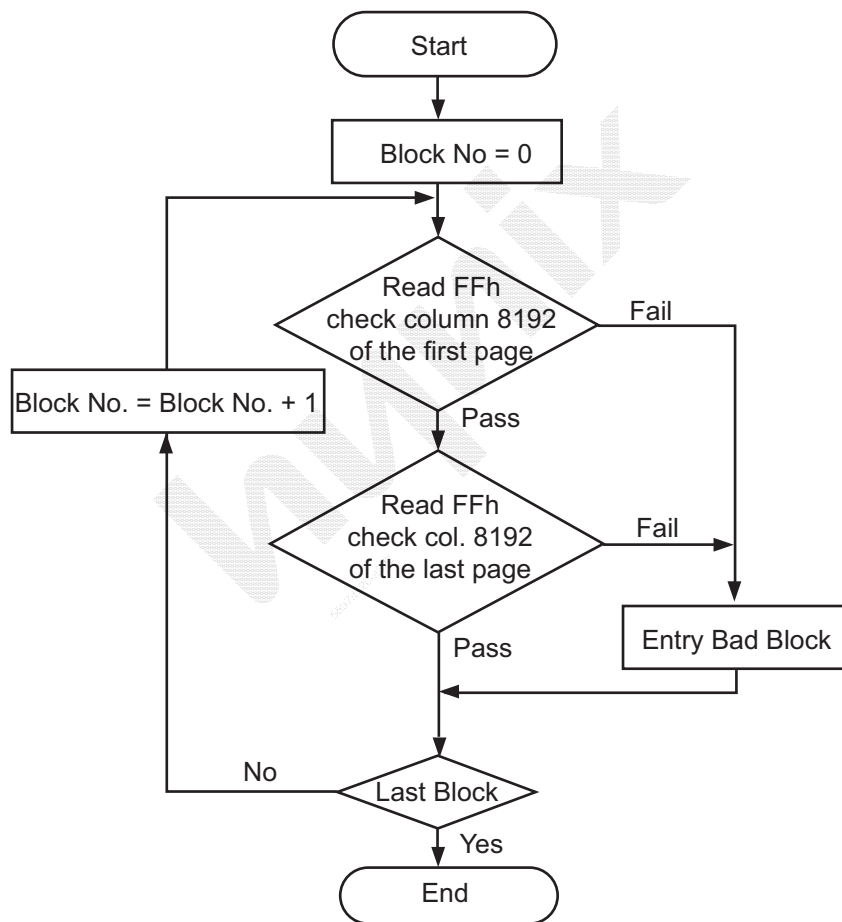

Notes:

1. Do not try to erase the detected bad blocks, because the bad block information will be lost.
2. Do not perform program and erase operation in invalid block, it is impossible to guarantee the input data and to ensure that the function is normal.

1.10. Bad Block Replacement

This device may have the invalid blocks when shipped from factory. An invalid block is one that contains one or more bad bits. Over the lifetime of the device additional Bad Blocks may develop. In this case, the block has to be replaced by copying the data to a valid block. These additional Bad Blocks can be identified as attempts to program or erase them will give errors in the Status Register.

The failure of a page program operation does not affect the data in other pages in the same block. Bad block can be replaced by re-programming the current data and copying the rest of the replaced block to an available valid block. Refer to Table 2 (*block failure*) and Figure 5 (*Block replacement*) for the recommended procedure to follow if an error occurs during an operation.

Table 2. Block failure

Operation	Recommended Procedure
Erase	Block Replacement
Program	Block Replacement
Read	ECC

■ **Figure 5. Block replacement**

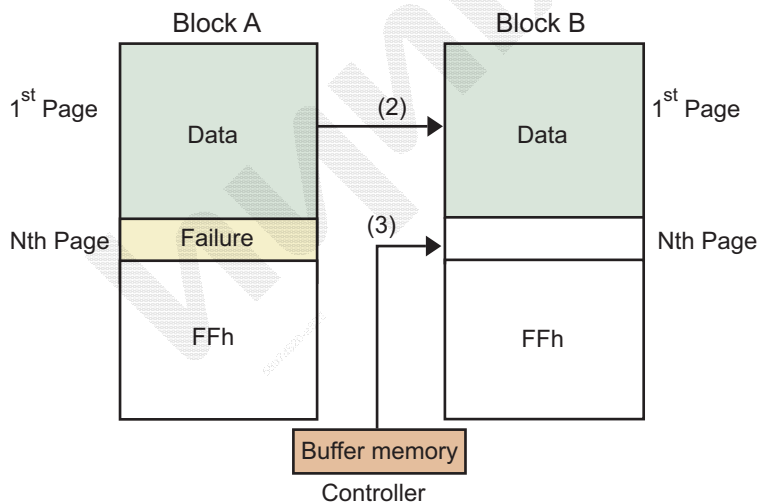

Notes:

1. An error occurs on nth page of the Block A during Program or Erase operation.
2. Data in Block A is copied to same location in Block B which is valid block.
3. Nth page of block A which is in controller buffer memory is copied into nth page of Block B.
4. Bad block table should be updated to prevent from erasing or programming Block A.

2. Electrical Characteristics

2.1. Valid Blocks

	Symbol	Min	Typ	Max	Unit
Valid Block Number	N_{VB}	999		1024	Blocks

Notes:

1. The 1st block is guaranteed to be a valid block at the time of shipment.
2. This single device has a maximum of 25 invalid blocks.
3. Invalid blocks are one that contains one or more bad bits. The device may contain bad blocks upon shipment.

2.2. Absolute Maximum Rating

Symbol	Parameter	Value	Unit
		Min	
T_A	Ambient Operating Temperature (Commercial Temperature Range)	0 to 70	°C
	Ambient Operating Temperature (Extended Temperature Range)	-25 to 85	°C
	Ambient Operating Temperature (Industrial Temperature Range)	-40 to 85	°C
T_{BIAS}	Temperature Under Bias	-50 to 125	°C
T_{STG}	Storage Temperature	-65 to 150	°C
V_{IO}	Input or Output Voltage	-0.6 to 4.6	V
V_{CC}	Supply Voltage	-0.6 to 4.6	V

Notes:

1. Except for the rating "Operating Temperature Range", stresses above those listed in the Table "Absolute Maximum Ratings" may cause permanent damage to the device. These are stress ratings only and operation of the device at these or any other conditions above those indicated in the Operating sections of this specification is not implied. Exposure to Absolute Maximum Rating conditions for extended periods may affect device reliability.
Refer also to the Hynix SURE Program and other relevant quality documents.
2. Minimum Voltage may undershoot to -2V during transition and for less than 20ns during transitions.

2.3. DC and Operating Characteristics

Parameter	Symbol	Test Conditions	H27UAG8T2B			Unit
			3.3V			
			Min	Typ	Max	
Power on reset current	I_{CC0}	FFh command input after power on	-	-	50per device	mA
Operating Current	Read	I_{CC1} $t_{RC} = t_{RC(min)}$, $CE\# = V_{IL}$, $I_{OUT} = 0$ mA	-	-	50	mA
	Program	I_{CC2}	-	-	50	mA
	Erase	I_{CC3}	-	-	50	mA
Stand-by Current (TTL)	I_{CC4}	$CE\# = V_{IH}$, $WP\# = 0V/V_{CC}$	-	-	1	mA
Stand-by Current (CMOS)	I_{CC5}	$CE\# = V_{CC} - 0.2$, $WP\# = 0V/V_{CC}$	-	10	50	μA
Input Leakage Current	I_{LI}	$V_{IN} = 0$ to $V_{CC(MAX)}$	-	-	± 10	μA
Output Leakage Current	I_{LO}	$V_{OUT} = 0$ to $V_{CC(MAX)}$	-	-	± 10	μA
Input High Voltage	V_{IH}	-	$V_{CC} \times 0.8$	-	$V_{CC} + 0.3$	V
Input Low Voltage	V_{IL}	-	-0.3	-	$0.2 \times V_{CC}$	V
Output High Voltage	V_{OH}	$I_{OH} = -200 \mu A$	2.4	-	-	V
Output Low Voltage	V_{OL}	$I_{OL} = 2.1$ mA	-	-	0.4	V
Output Low Current (R/B#)	$I_{OL(R/B\#)}$	$V_{OL} = 0.4V$	8	10	-	mA

2.4. AC Test Conditions

Parameter	Value
	$2.7V \leq V_{CC} \leq 3.6V$
Input Pulse Levels	0 V to V_{CC}
Input Rise and Fall Times	5 ns
Input and Output Timing Levels	$V_{CC} / 2$
Output Load (2.7V-3.6V)	1 TTL GATE and $CL = 50$ pF

Notes:

1. These parameters are verified device characterization and are not 100% tested.

2.5. Pin Capacitance ($T_A=25^\circ\text{C}$, $F=1.0\text{MHz}$)

Symbol	Parameter	Test Condition	Min	Max	Unit
C_{IN}	Input Capacitance	$V_{IN} = 0V$	-	10	pF
$C_{I/O}$	Input/Output Capacitance	$V_{IN} = 0V$	-	10	pF

2.6. Program/ Read / Erase Characteristics

Parameter	Symbol	Min	Typ	Max	Unit
Program (following 10h)	t_{PROG}	-	1600	5000	μs
Cache Program (following 15h)	t_{CBSYW}	-	-	5000	μs
multi plane Program / multi plane Cache Program / multi plane Copy-Back Program (following 11h)	t_{DBSY}	-	3	5	μs
Cache Read / multi plane Cache Read (following 31h/3Fh)	t_{CBSYR}	-	3	200	μs
Block Erase / multi plane Block Erase	t_{BERS}	-	2.5	10	ms
Number of partial Program Cycles in the same page	NOP	-	-	1	cycles

Notes:

1. Typical value is measured at $V_{CC}=3.3V$, $T_A=25^\circ\text{C}$. Not 100% tested.

2.7. AC Timing Characteristics

Parameter	Symbol	3.3V		Unit
		Min	Max	
CLE setup time	t_{CLS}	12		ns
CLE Hold time	t_{CLH}	5		ns
CE# setup time	t_{CS}	20		ns
CE# hold time	t_{CH}	5		ns
WE# pulse width	t_{WP}	12		ns
ALE setup time	t_{ALS}	12		ns
ALE hold time	t_{ALH}	5		ns
Data setup time	t_{DS}	12		ns
Data hold time	t_{DH}	5		ns
Write cycle time	t_{WC}	25		ns
WE# high hold time	t_{WH}	10		ns
Data transfer from cell to register	t_R		200	μs
ALE to RE# delay	t_{AR}	10		ns
CLE to RE# delay	t_{CLR}	10		ns
Ready to RE# low	t_{RR}	25		ns
RE# pulse width	t_{RP}	12		ns
WE# high to busy	t_{WB}		100	ns
Read cycle time	t_{RC}	25		ns
RE# access time	t_{REA}		20	ns
RE# high to output high Z	t_{RHZ}		100	ns
CE# high to output high Z	t_{CHZ}		50	ns
RE# high to output hold	t_{RHOH}	15		ns
RE# low to output hold	t_{RLOH}	5		ns
RE# or CE# high to output hold	t_{COH}	15		ns
RE# high hold time	t_{REH}	10		ns
CE# low to RE# low	t_{CR}	10		ns
WE# high to RE# low	t_{WHR}	100		ns
RE# high to WE# low	t_{RHW}	100		ns
Output high Z to RE# low	t_{IR}	0		ns
Address to data loading time	t_{ADL}	100		ns

Device resetting time (Read/Program/Erase)	t_{RST}		20/30/500	μs
Write protection time	t_{WW}	100		ns

Notes:

1. If Reset Command (FFh) is written at Ready state, the device goes into Busy for maximum 5us.
2. Program / Erase Enable Operation: WP# high to WE# High.
 Program / Erase Disable Operation: WP# Low to WE# High.
3. The transition of the corresponding control pins must occur only while WE# is held low.
4. t_{ADL} is the time from the WE# rising edge of final address cycle to the WE# rising edge of first data cycle.

2.8. Status Register Coding

I/O	Page Program	Block Erase	Read	Cache Read	Cache Program	Coding
						70h/ 78h
0	Pass/ Fail	Pass/ Fail	N/A	N/A	Pass/ Fail	N page Pass : '0' Fail : '1'
1	N/A	N/A	N/A	N/A	Pass/ Fail	N-1 page Pass : '0' Fail : '1'
2	N/A	N/A	N/A	N/A	N/A	'0'
3	N/A	N/A	N/A	N/A	N/A	'0'
4	N/A	N/A	N/A	N/A	N/A	'0'
5	N/A	N/A	N/A	Ready / Busy	Ready / Busy	Ready / Busy Busy : '0' Ready : '1'
6	Ready / Busy	Ready / Busy	Ready / Busy	Ready / Busy	Ready / Busy	Data Cache Ready / Busy : '0' Ready : '1'
7	Write Protect	Write Protect	Write Protect	Write Protect	Write Protect	Protected : '0' Not Protected : '1'

Notes:

1. I/O0: This bit is only valid for Program and Erase operations. During Cache Program operations, this bit is only valid when I/O5 is set to one.
2. I/O1: This bit is only valid for cache program operations. This bit is not valid until after the second 15h command or the 10h command has been transferred in a Cache program sequence. When Cache program is not supported, this bit is not used.
3. I/O5: If set to one, then there is no array operation in progress. If cleared to zero, then there is a command being processed (I/O6 is cleared to zero) or an array operation in progress. When overlapped interleaved operations or cache commands are not supported, this bit is not used.
4. I/O6: If set to one, then the device or interleaved address is ready for another command and all other bits in the status value are valid. If cleared to zero, then the last command issued is not yet complete and Status Register bits<5:0> are invalid value. When cache operations are in use, then this bit indicates whether another command can be accepted, and I/O5 indicates whether the last operation is complete.

2.9. Device Identifier Coding

Parameter	Symbol
Device Identifier Byte	Description
1 st	Manufacturer Code
2 nd	Device Identifier
3 rd	Internal chip number, cell Type, Number of Simultaneously Programmed Pages, Interleaved Program, Write Cache.
4 th	Page size, Block size, Redundant area size
5 th	Plane Number, ECC Level
6 th	Technology (Design Rule), EDO, Interface

2.10. Read ID Data Table

Part Number	Voltage	Bus Width	Manufacture Code	Device Code	3 rd	4 th	5 th	6 th
H27UAG8T2B	3.3V	X8	ADh	D5h	94h	9Ah	74h	42h

2.10.1. 3rd Byte of Device Identifier Description

3 rd cycle	Description	I/O 7	I/O 6	I/O 5	I/O 4	I/O 3	I/O 2	I/O 1	I/O 0
Internal Chip Number	1							0	0
	2							0	1
	4							1	0
	Reserved							1	1
Cell Type	2 Level Cell					0	0		
	4 Level Cell					0	1		
	8 Level Cell					1	0		
	16 Level Cell					1	1		
Number of Simultaneously Programmed Pages	1			0	0				
	2			0	1				
	4			1	0				
	8			1	1				
Interleaved Program between Multiple dice	Supported		0						
	Not Supported		1						
Write Cache	Not Supported	0							
	Supported	1							

2.10.2. 4th Byte of Device Identifier Description

4 th cycle	Description	I/O 7	I/O 6	I/O 5	I/O 4	I/O 3	I/O 2	I/O 1	I/O 0
Page Size (Without Spare Area)	2KB							0	0
	4KB							0	1
	8KB							1	0
	Reserved							1	1
Block Size (Without Spare area)	128KB	0		0	0				
	256KB	0		0	1				
	512KB	0		1	0				
	768KB	0		1	1				
	1MB	1		0	0				
	2MB	1		0	1				
	Reserved	1		1	0				
Reserved	1		1	1					
Redundant Area Size	128B		0			0	0		
	224B		0			0	1		
	448B		0			1	0		
	Reserved		0			1	1		
	Reserved		1			0	0		
	Reserved		1			0	1		
	Reserved		1			1	0		
Reserved		1			1	1			

2.10.3. 5th Byte of Device Identifier Description

5 th cycle	Description	I/O 7	I/O 6	I/O 5	I/O 4	I/O 3	I/O 2	I/O 1	I/O 0
Plane Number	1					0	0		
	2					0	1		
	4					1	0		
	8					1	1		
ECC Level	1bit/512Bytes		0	0	0				
	2bit/512Bytes		0	0	1				
	4bit/512Bytes		0	1	0				
	8bit/512Bytes		0	1	1				
	16bit/512Bytes		1	0	0				
	24bit/2048Bytes		1	0	1				
	24bit/1024Bytes		1	1	0				
Reserved		1	1	1					
Reserved		0						0	0

2.10.4. 6th Byte of Device Identifier Description

6 th cycle	Description	I/O 7	I/O 6	I/O 5	I/O 4	I/O 3	I/O 2	I/O 1	I/O 0
NAND Technology	48nm						0	0	0
	41nm						0	0	1
	32nm						0	1	0
	Reserved						0	1	1
	Reserved						1	0	0
	Reserved						1	0	1
	Reserved						1	1	0
	Reserved						1	1	1
EDO Support	Not Support Support		0 1						
NAND Interface	SDR DDR	0 1							
Reserved				0	0	0			



3. Timing Diagram

Bus Operation

There are six standard bus operations that control the device. These are Command Input, Address Input, Data Input, Data Output, Write Protect, and Standby.

3.1. Command Latch Cycle Timings

■ Figure 6. Command latch timings

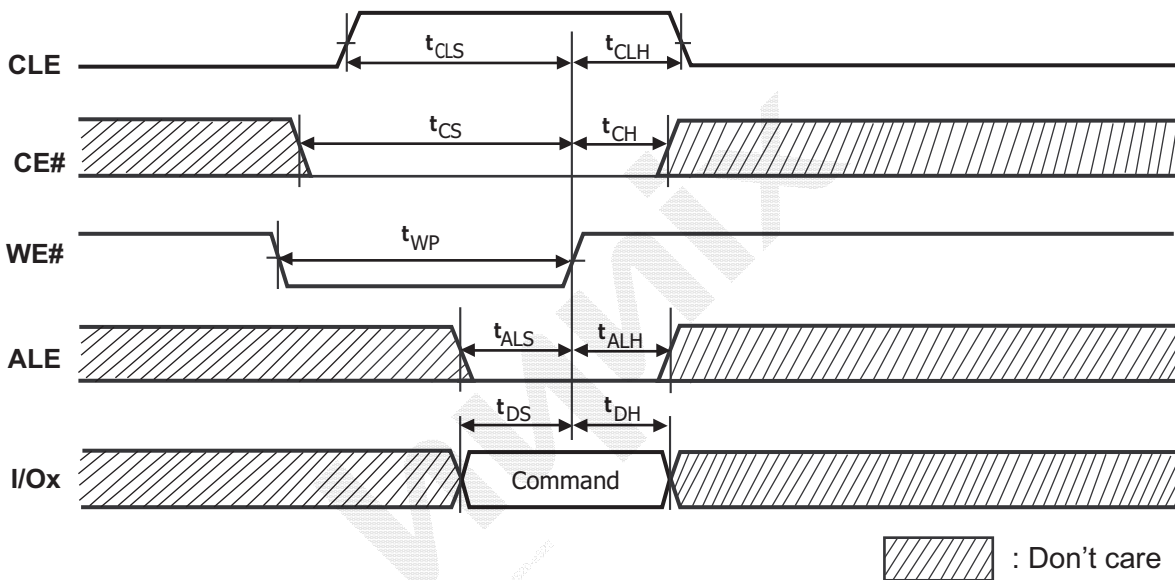

Note:

All commands except Reset, Read Status, and Multi Plane Read Status are issued to command register on the rising edge of WE#, when CLE is high, CE# and ALE is low, and device is not busy state

3.2. Address Latch Cycle Timings

■ Figure 7. Address latch timings

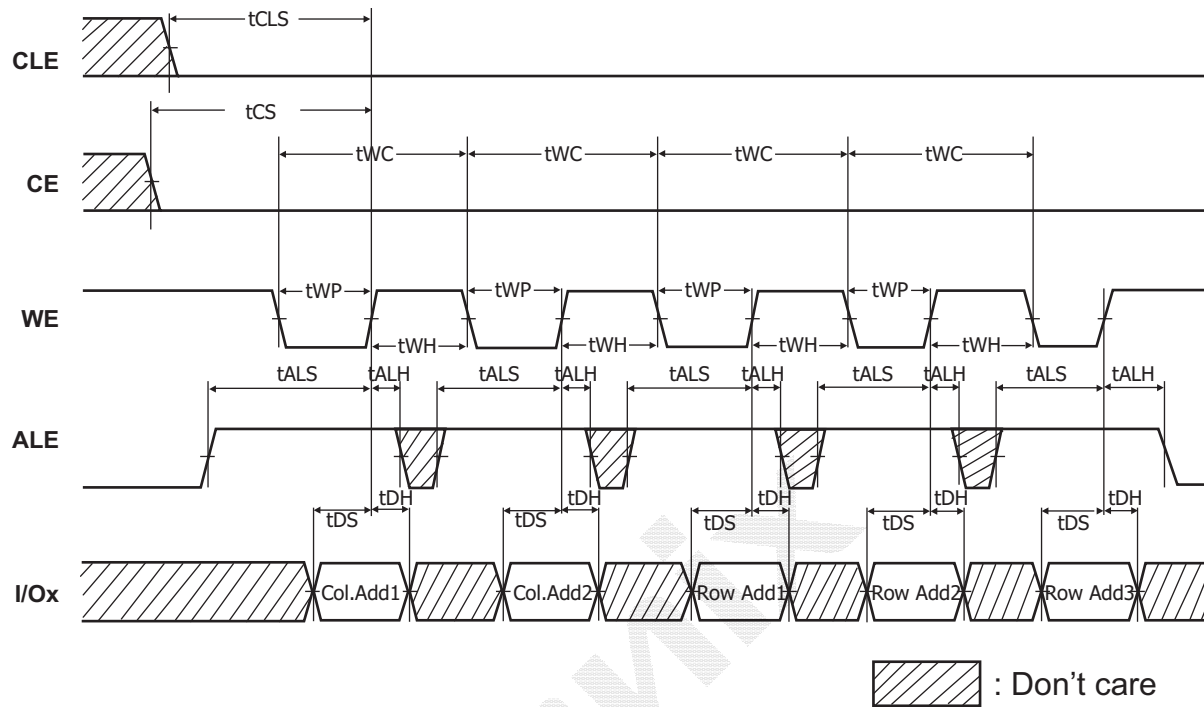

3.3. Input Data Latch Cycle Timings

■ Figure 8. Input data cycle timings

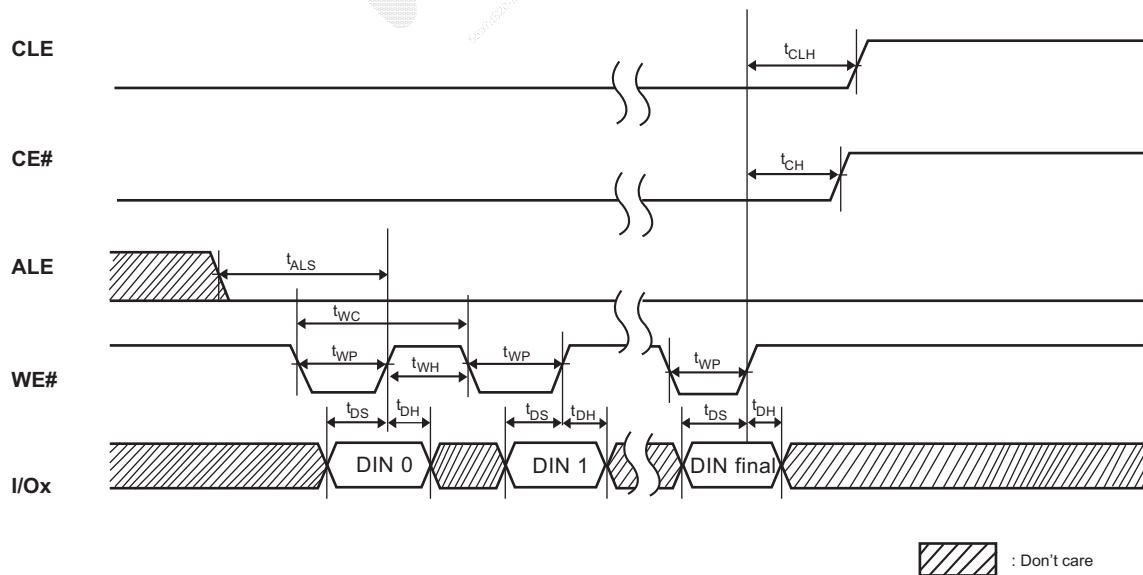

Note:

Data Input cycle is accepted to data register on the rising edge of WE#, when CLE and CE# and ALE are low, and device is not Busy state.

3.4. Data Output Cycle Timings (CLE=L, WE#=H, ALE=L, WP#=H)

■ Figure 9. Data output cycle timings

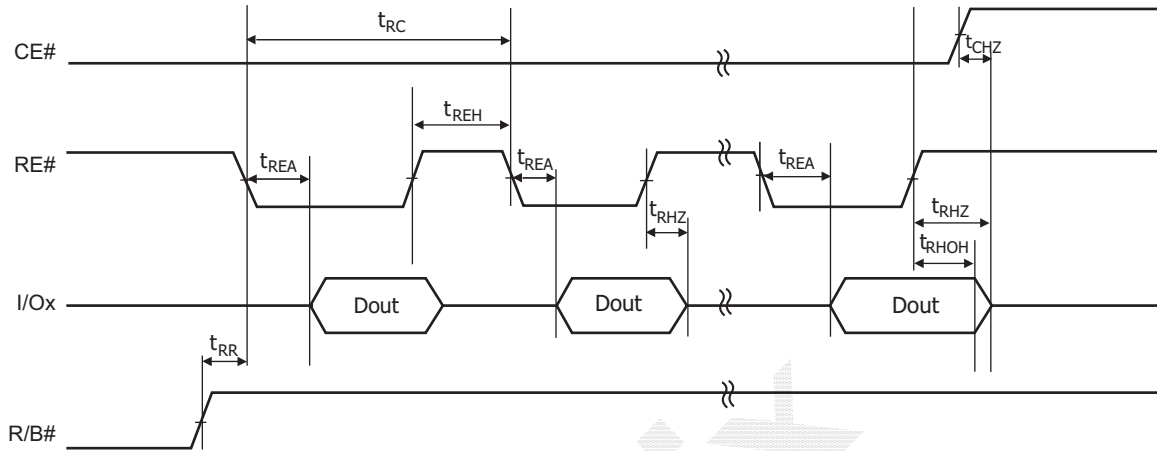

Notes:

1. Transition is measured +/-200mV from steady state voltage with load.
 This parameter is sampled and not 100% tested. (t_{CHZ} , t_{RHZ})
2. t_{RLOH} is valid when frequency is higher than 33MHz.
 t_{RHOH} starts to be valid when frequency is lower than 33MHz.

3.5. Data Output Cycle Timings (EDO type, CLE=L, WE#=H, ALE=L)

■ Figure 10. Data output cycle timings (EDO)

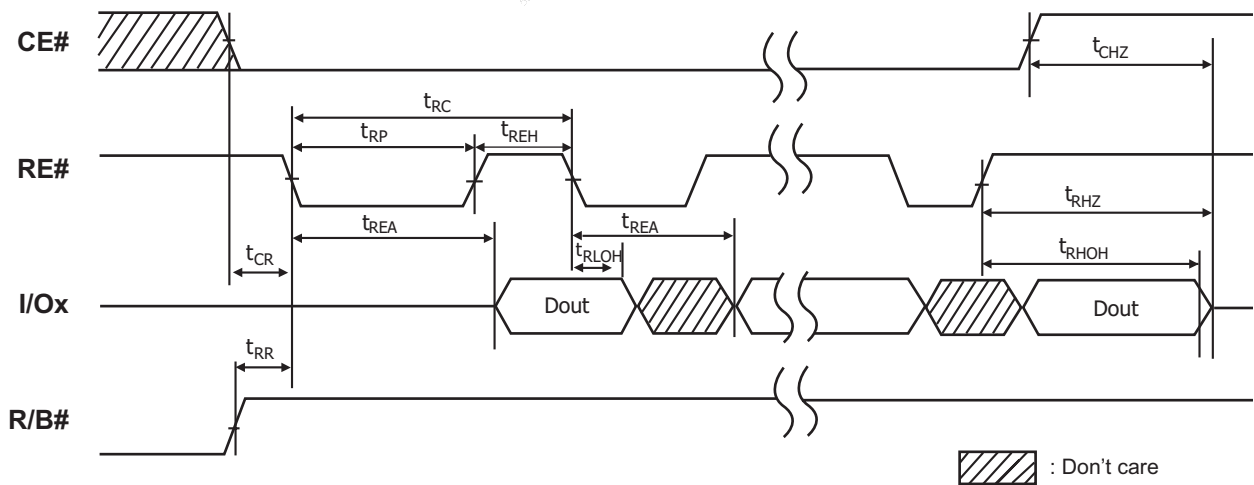

Notes:

1. Transition is measured +/-200mV from steady state voltage with load.
 This parameter is sampled and not 100% tested. (t_{CHZ} , t_{RHZ})

- 2. t_{RLOH} is valid when frequency is higher than 33MHz.
 t_{RHOH} starts to be valid when frequency is lower than 33MHz.

3.6. Read Status Cycle Timings

■ Figure 11. Read status timings

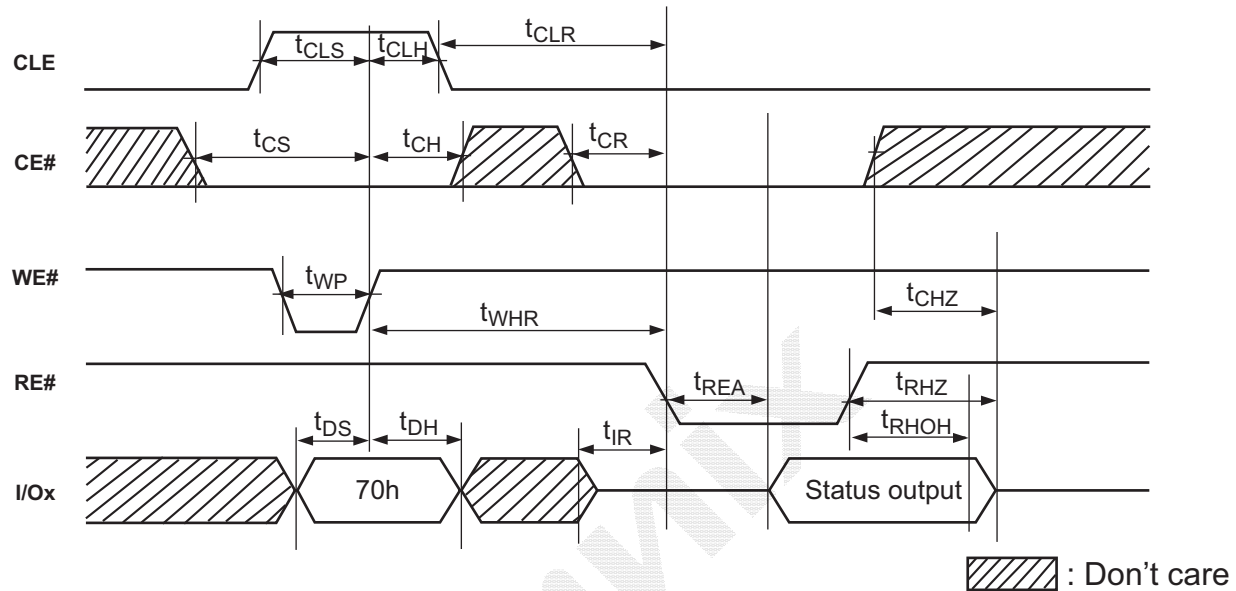

3.7. Multi Plane Read Status Timings

■ Figure 12. Multi plane read status timings

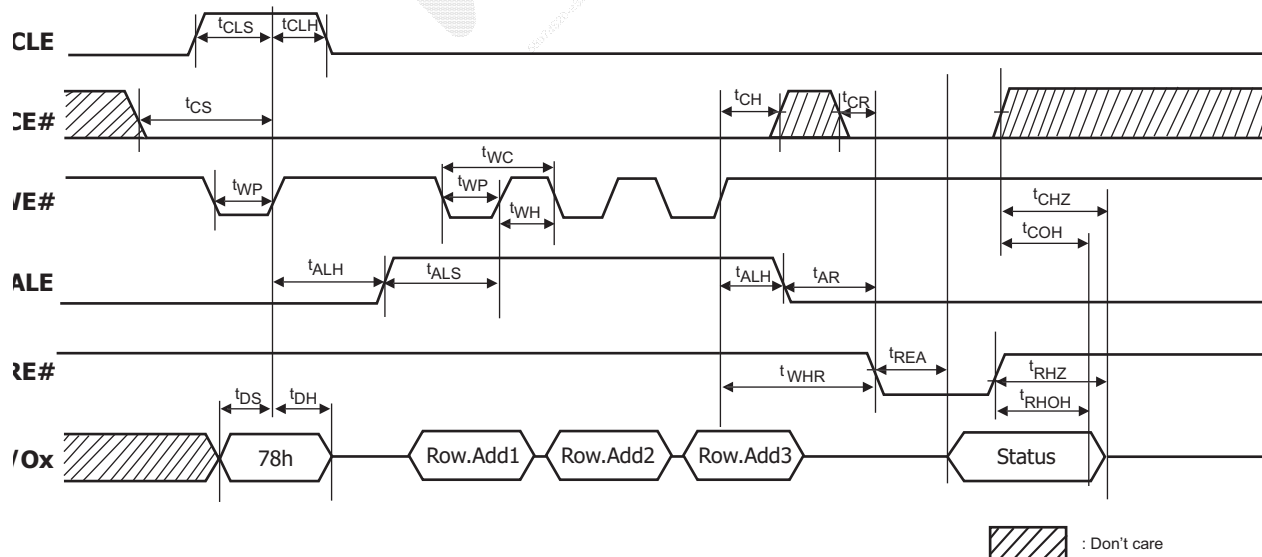

3.8. Page Read Operation Timings (Read One Page)

■ Figure 13. Page read operation timings

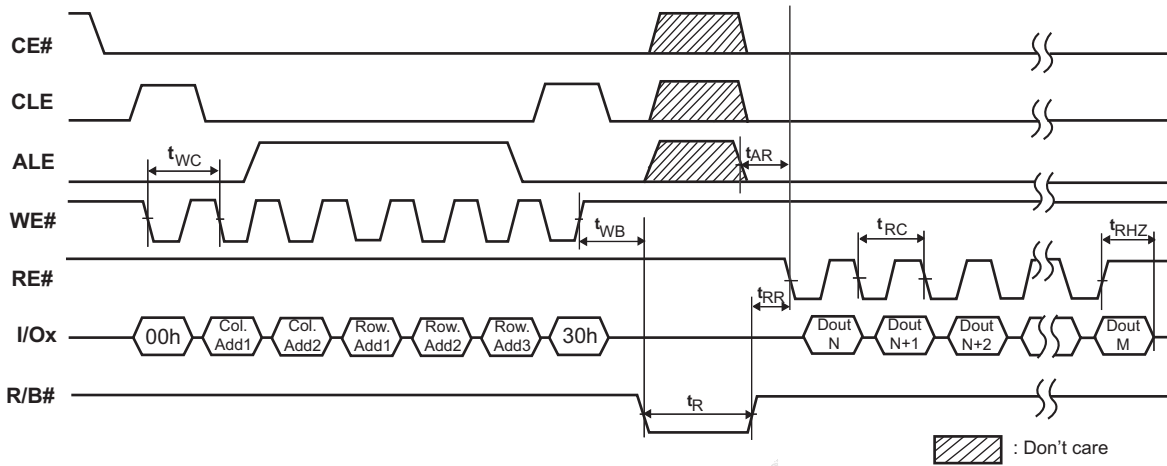

3.9. Page Read Operation Timings (Intercepted by CE#)

■ Figure 14. Page read operation timings

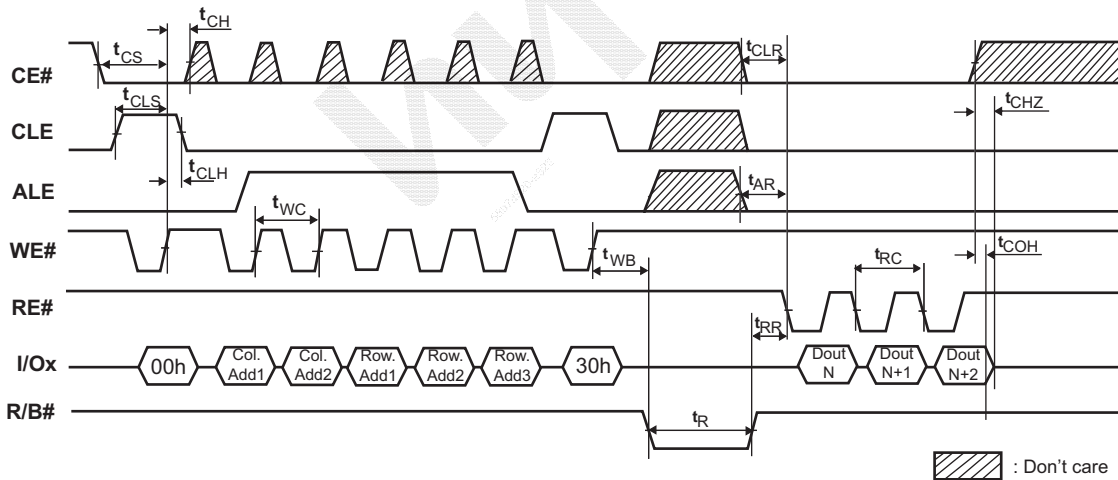

3.10. Page Read Operation Timings with CE# don't care

■ Figure 15. Page read operation timings with CE# don't care

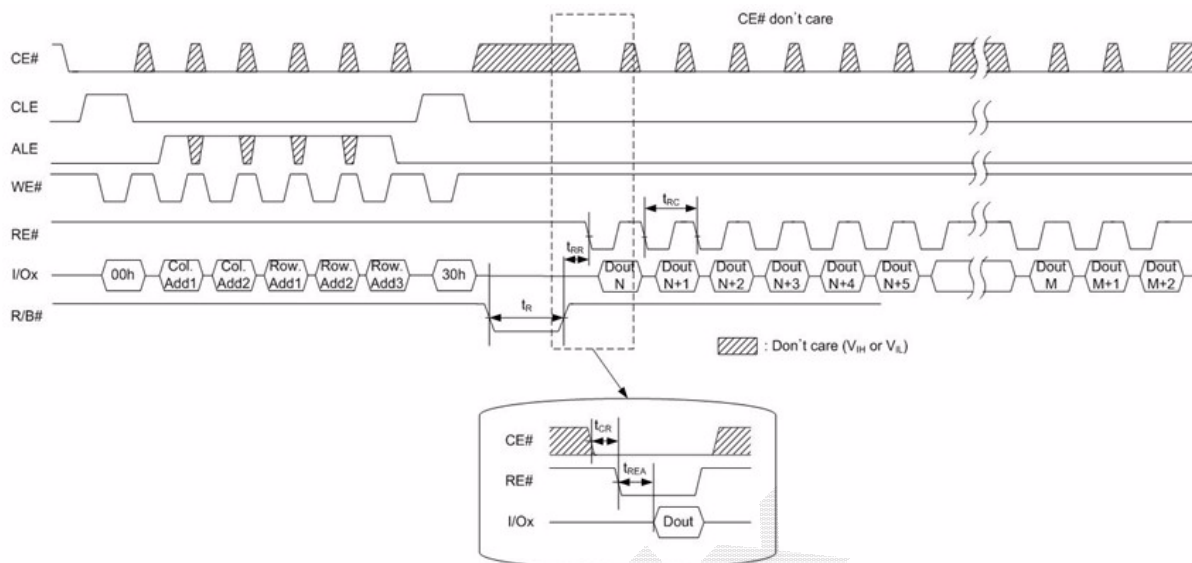

Note:
 Random data output is available within a page.

3.11. Random Data Output Timings

■ Figure 16. Random data output timings

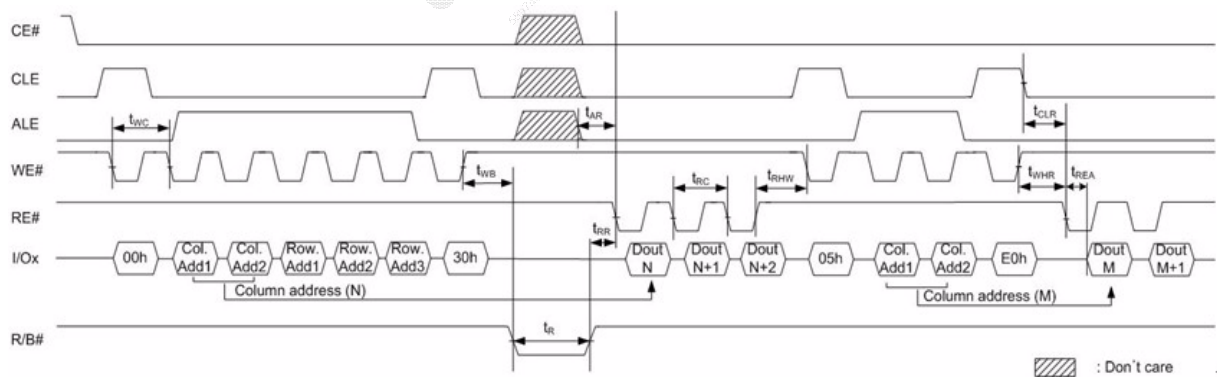

Note:
 Random data output is available within a page.

3.13. Cache Read Operation Timings

■ Figure 18. Cache read operation timings

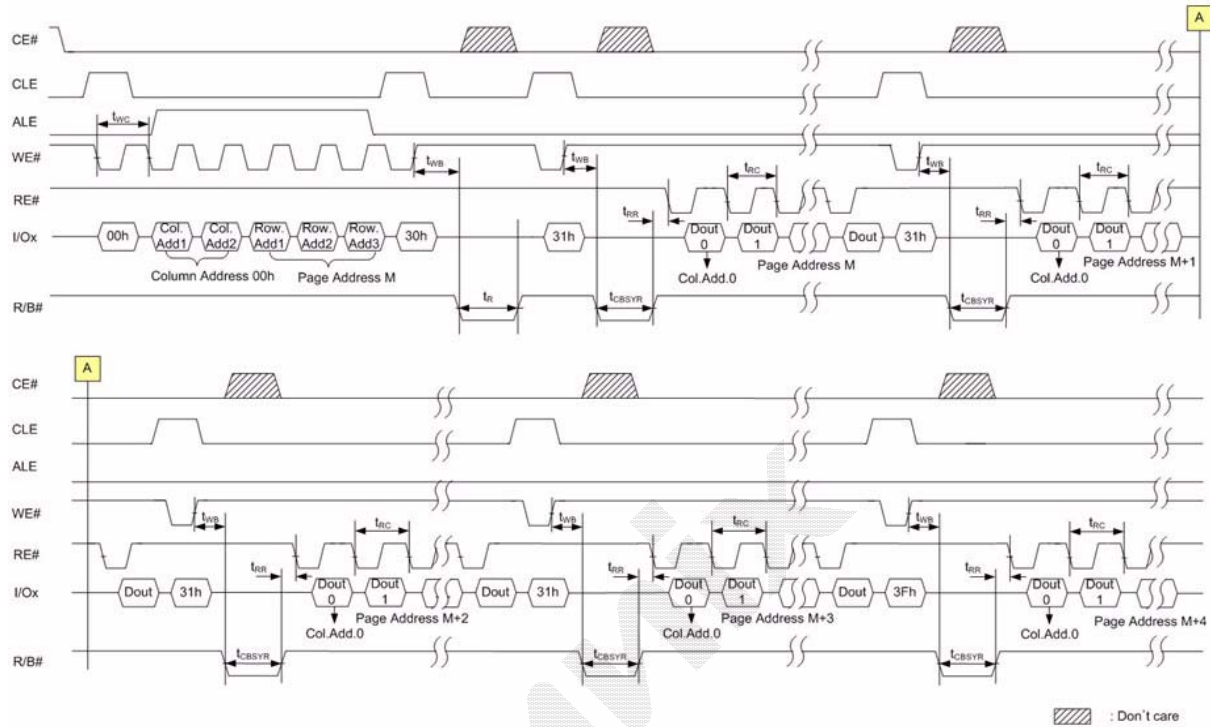

Notes:

1. The column address will be reset to 0 by the 31h/3Fh command input.
2. Cache read operation is available only within a block.

3.14. Multi Plane Cache Read Operation Timings

■ Figure 19. Multi plane cache read operation Timings

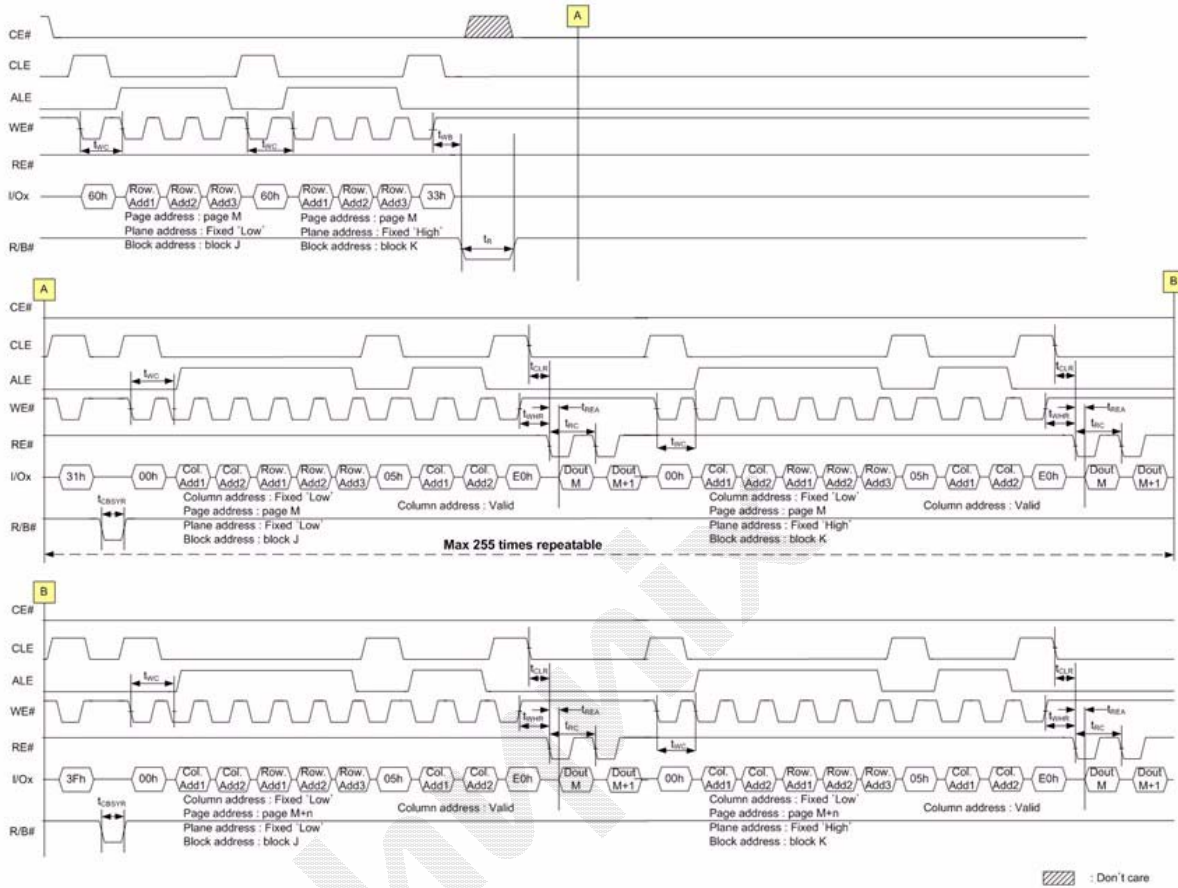

Notes:

1. The column address will be reset to 0 by the 31h/3Fh command input.
2. Cache read operation is available only within a block.
3. Make sure to terminate the operation with 3Fh command. If the page read operation is completed, issue FFh reset before next operation.
4. Multi Plane Page addresses are required to be the same.
5. Multi Plane cache read must be used after Multi plane programmed page, multi plane cache program, and multi plane copy-back program

3.15. Read ID Operation Timings

■ Figure 20. Read ID operation timings

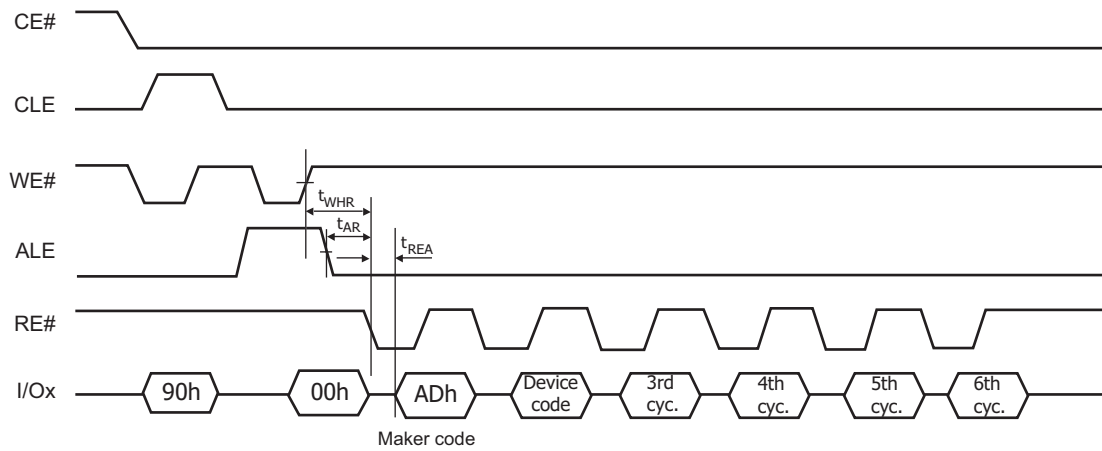

3.16. Page Program Operation Timings

■ Figure 21. Page program operation timings

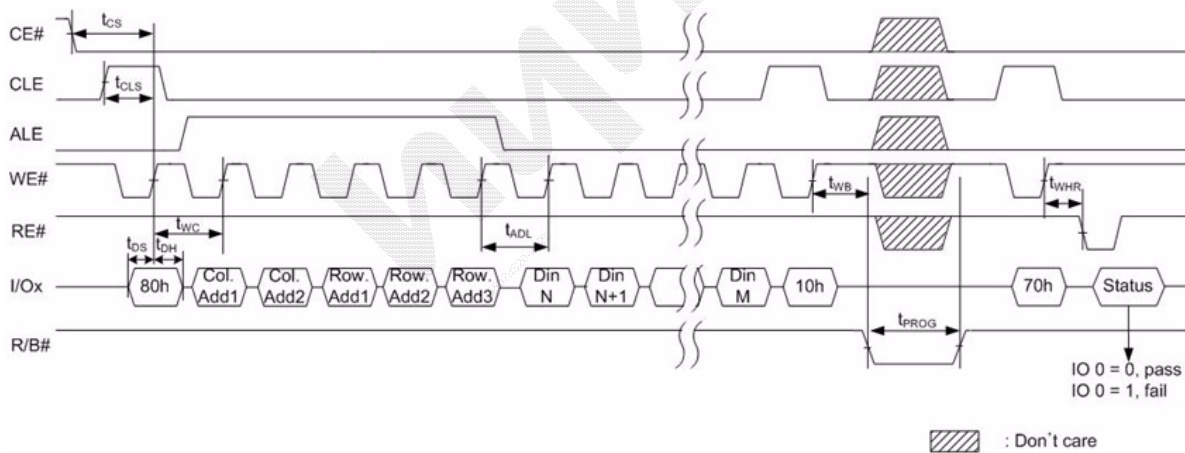

Note:

t_{ADL} is the time from the WE# rising edge of final address cycle to the WE# rising edge of first data cycle.

3.17. Page Program Operation Timings with CE# don't care

■ Figure 22. Page program operation timings with CE# don't care

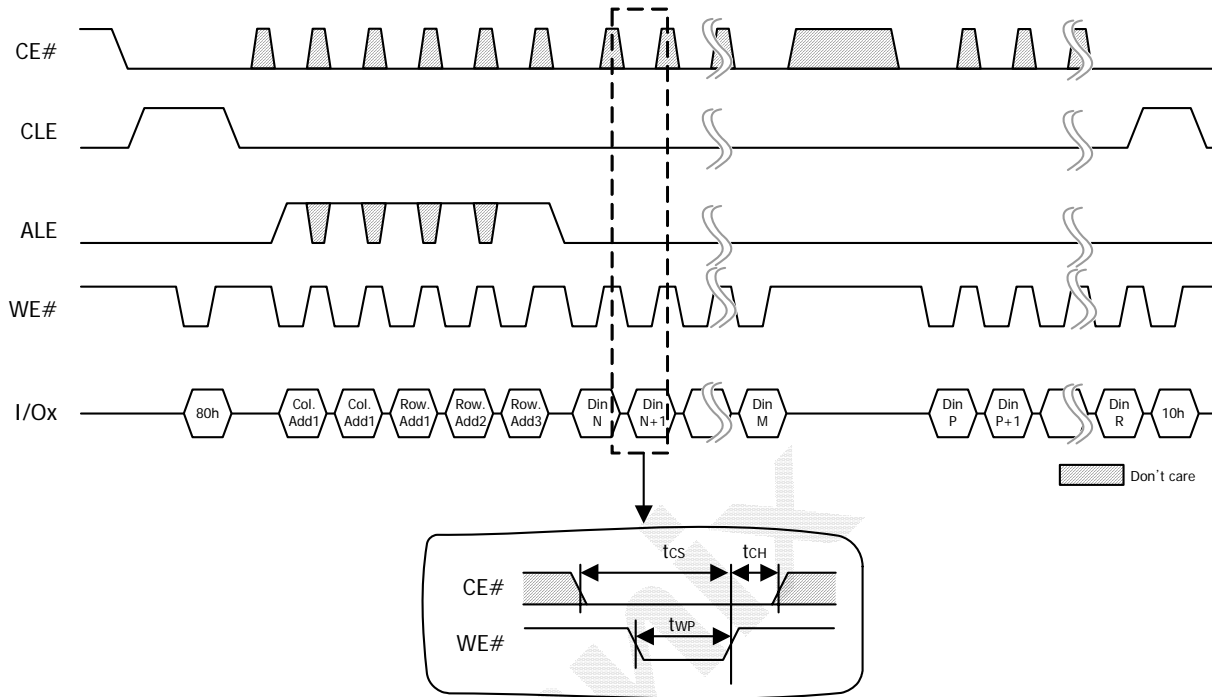

Note:

t_{ADL} is the time from the WE# rising edge of final address cycle to the WE# rising edge of first data cycle.

3.18. Random Data Input Timings

■ Figure 24. Random data input timings

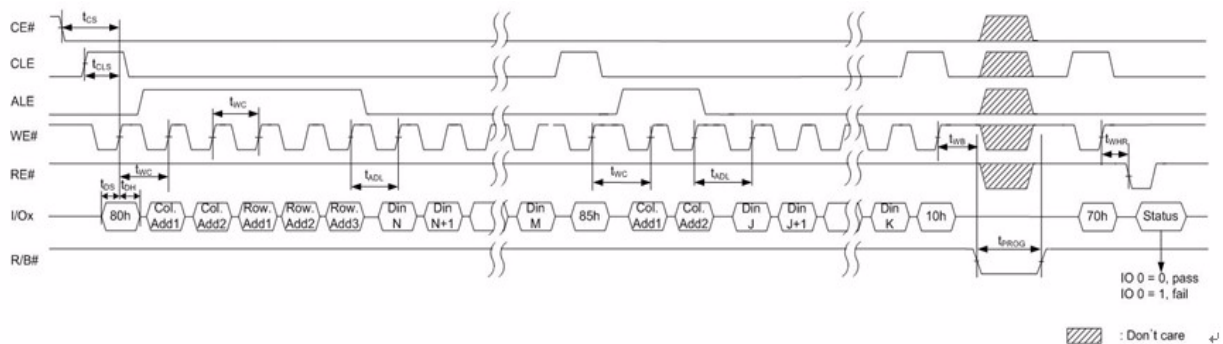

Notes:

1. t_{ADL} is the time from the WE# rising edge of final address cycle to the WE# rising edge of first data cycle.
2. Random data input can be performed in a page.

3.19. Multi Plane Page Program Operation Timings

■ Figure 25. Multi plane page program operation timing

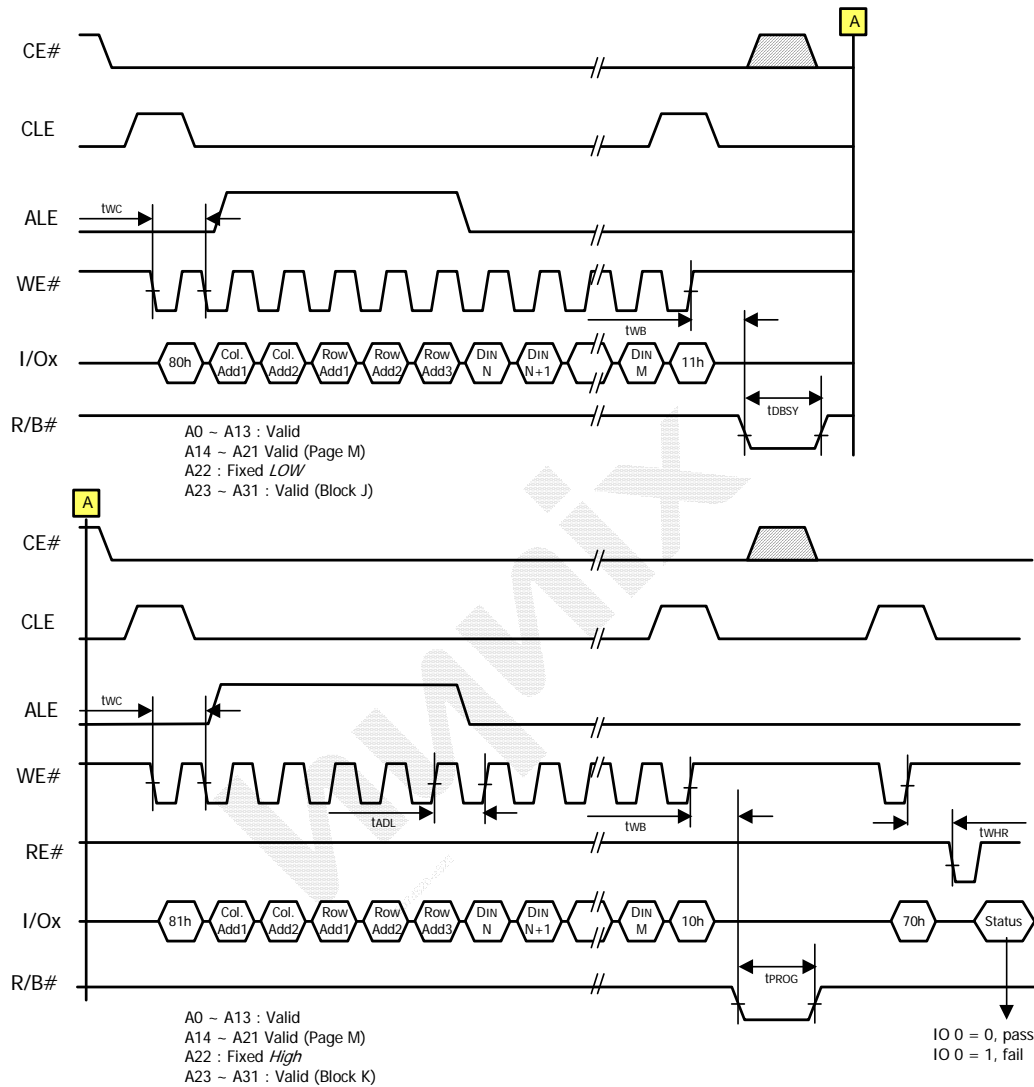

Notes:

1. Any command between 11h and 81h is prohibited except 70h, 78h and FFh
2. t_{ADL} is the time from the WE# rising edge of final address cycle to the WE# rising edge of first data cycle.
3. Multi Plane Page addresses are required to be the same.

3.20. Copy-Back Program Operation Timings with Random Date Input

■ Figure 26. Copyback program operation timing with random data input

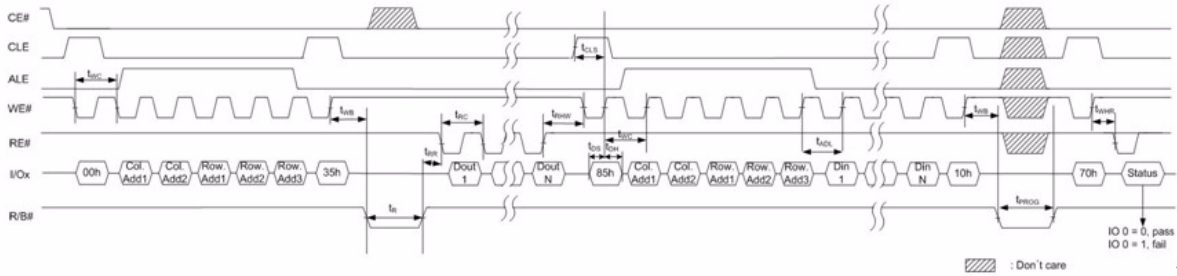

Notes:

- Copy back operation is allowed only within the same memory plane.

3.21. Cache Program Operation Timings

■ Figure 27. Cache program operation timings

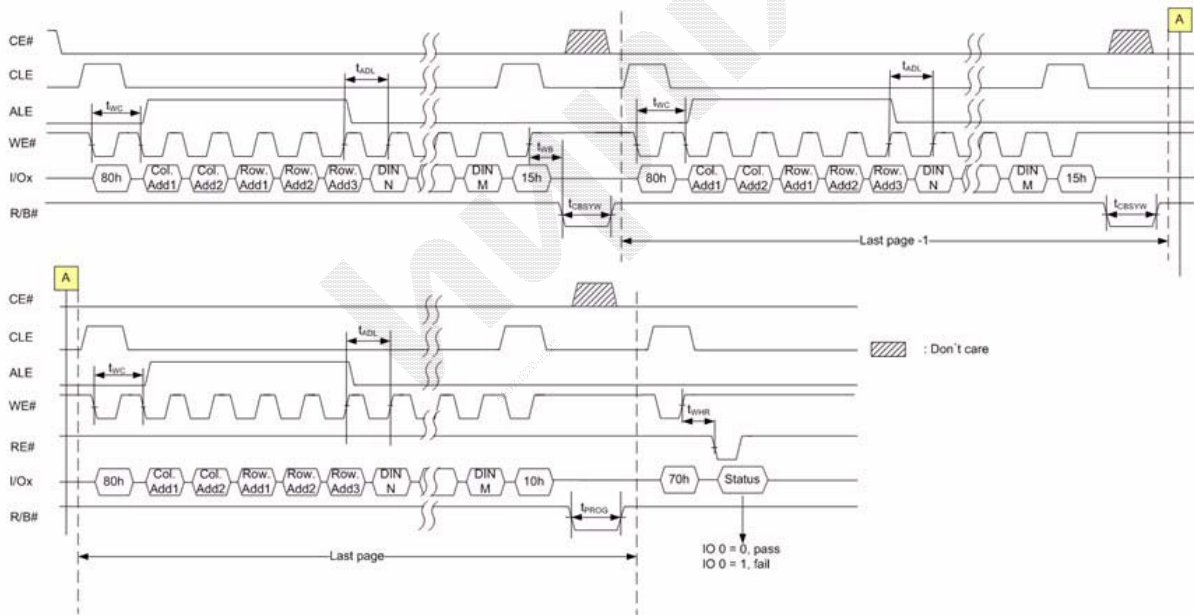

Note:

$$t_{PROG} = \text{Program time for the last page} + \text{Program time for the (last - 1)th page} - (\text{command input cycle time} + \text{address input cycle time} + \text{Last page data loading time})$$

3.22. Multi Plane Cache Program Operation Timings

■ Figure 28. Multi plane cache program operation timings

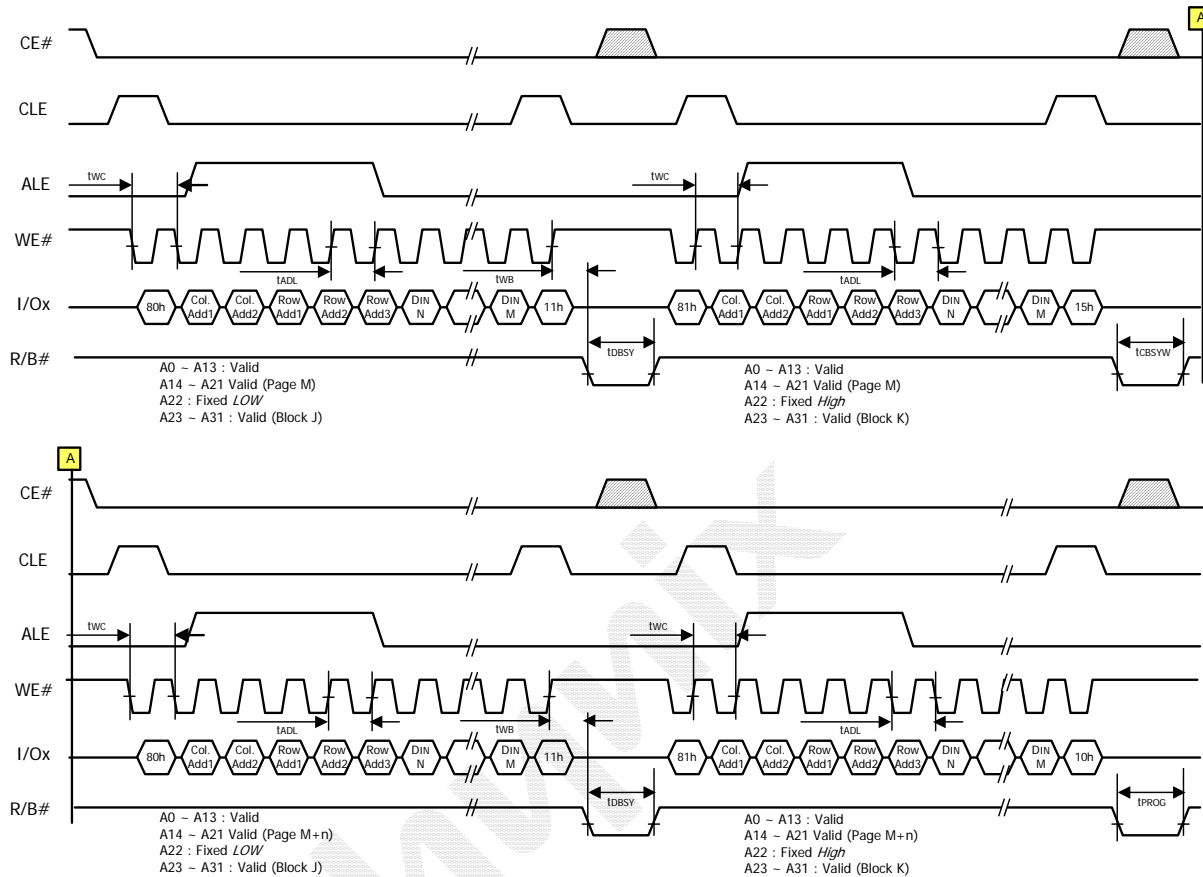

Notes:

1. t_{PROG} = Program time for the last page + Program time for the (last -1)th page - (command input cycle time + address input cycle time + Last page data loading time)
2. Make sure to terminate the operation with 80h-10h- command sequence. If the operation is terminated, Issue FFh reset before next operation.
3. Selected Page address except A22 within two blocks must be same.

3.23. Block Erase Operation Timings

■ Figure 29. Block erase operation timings

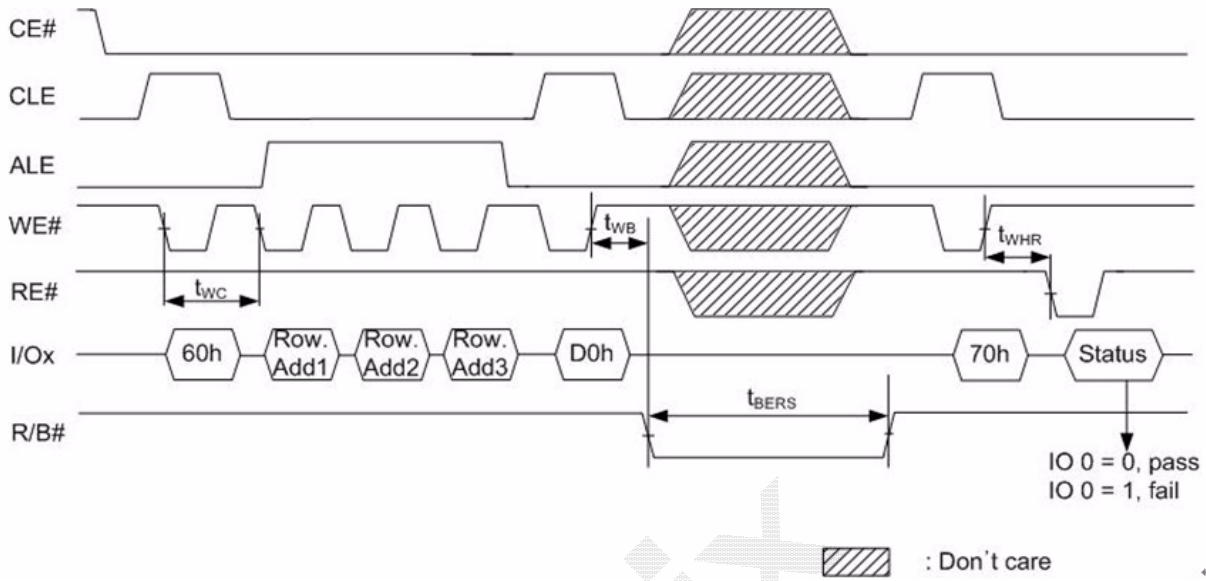

3.24. Multi Plane Erase Operation Timings

■ Figure 30. Multi plane erase operation timings

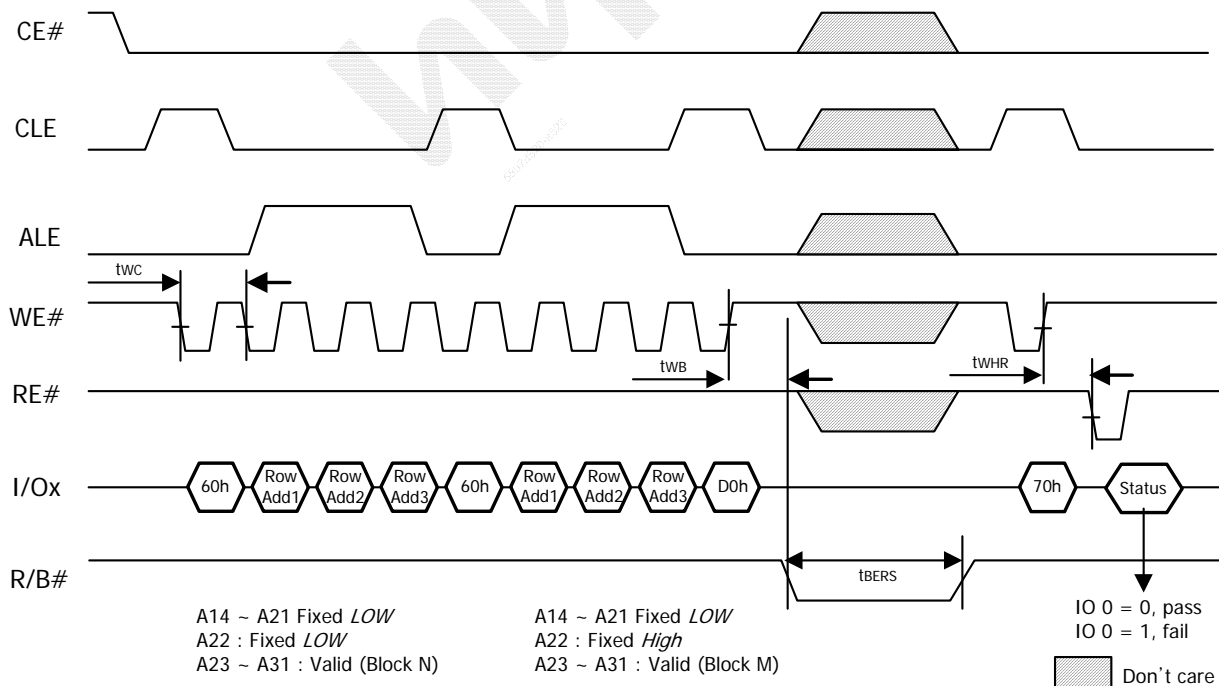

3.25. Reset Timings

■ Figure 31. Reset timings

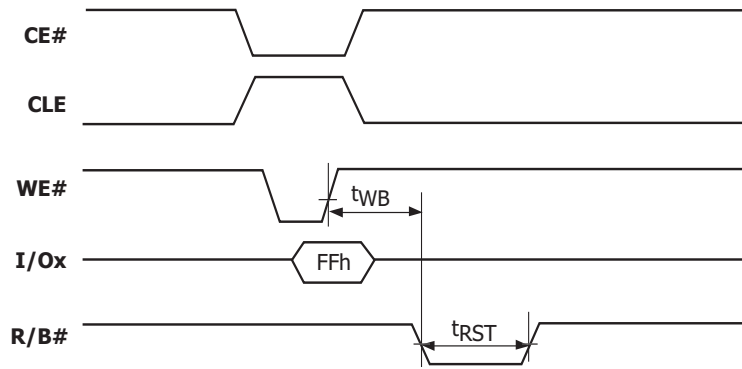

4. DEVICE OPERATION

4.1. Page Read

This operation is initialized by 00h-30h to the command register along with followed by five address input cycles. The 8,640 bytes of data within the selected page are transferred to the data registers in less than $200\mu\text{s}$ (t_R). The system controller may detect the completion of this data transfer $200\mu\text{s}$ (t_R) by analyzing the output of R/B# pin. Once the data in a page is loaded into the data registers, they may be read out in 25ns cycle time by sequentially pulsing RE#.

The repetitive high to low transitions of the RE# clock make the device output the data starting from the selected column address up to the last column address. The device may output random data in a page instead of the consecutive sequential data by writing random data output command. The column address of next data, which is going to be out, may be changed to the address, which follows random data output command. Random data output can be operated multiple times, regardless of how many times it is done in a page.

■ **Figure 32. Page read**

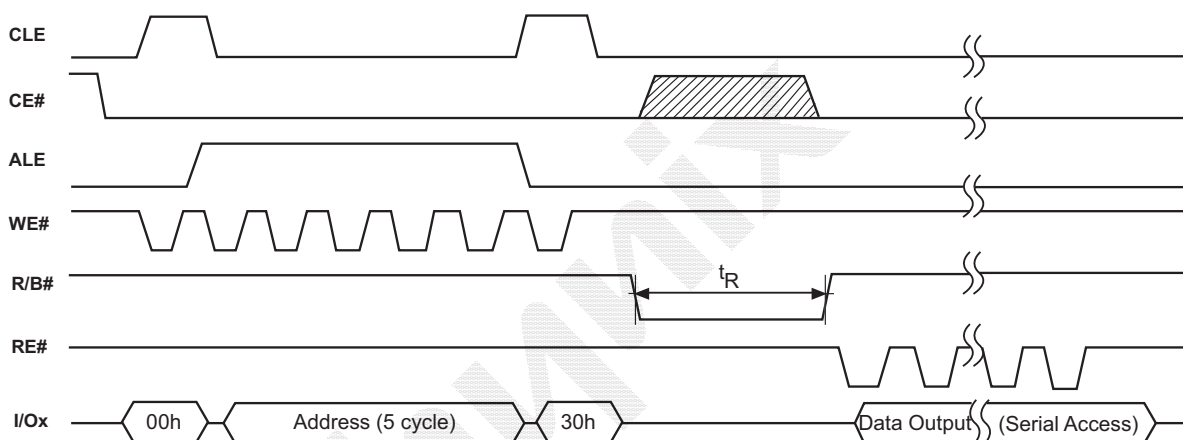

Random data output

Random data output operation changes the column address from which data is being read in the page register. Random data output only is issued in Ready state. Refer to Figure 33.

■ **Figure 33. Random data output**

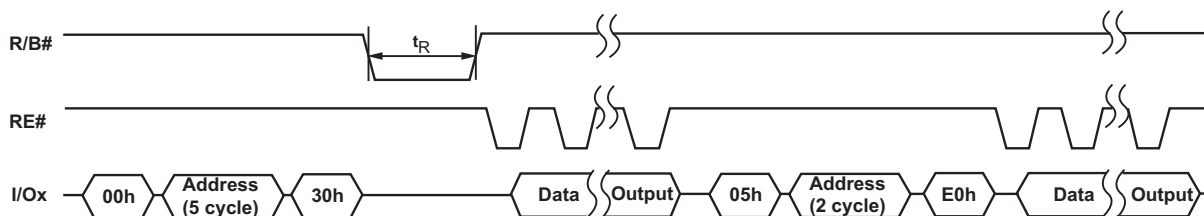

4.2. Cache Read (available only within a block)

To improve page read throughput, cache read operation is used within a block. First step is same as normal page read, issuing a page read sequence (00-30h). After random access (R/B# returns to high), 31h command is latched into the command register. Data is being transferred from the data register to the cache register. While cache register data is outputted, next page is transferred from memory cell to data register. R/B# will stay low during present page random accessing and previous page transferring to cache register. Because it is not necessary to output a whole page data before issuing another 31h command, if serial data output time exceeds random access time (t_R), the random access time can be hidden. The subsequent pages are issued additional 31h commands. To terminate cache read, 3Fh command should be issued. This command transfer data from data register to the cache register without issuing next page read. During the Cache Read Operation, device doesn't allow any other command except Cache Read command (31h), Read Status (70h, 78h), Read (00h), and Reset (FFh). To carry out other operations after cache operation, cache read must be ended by 3Fh command or issue reset (FFh) before next operation.

■ Figure 34. Cache read

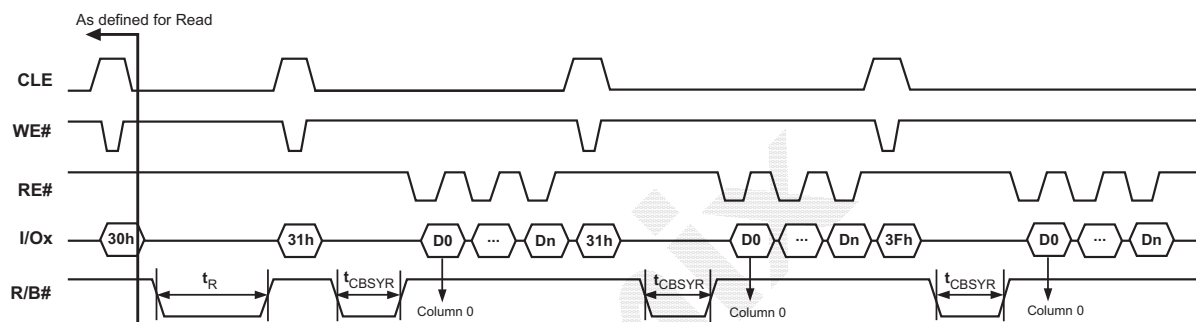

4.3. Multi Plane Page Read

Multi plane Page Read is an extension of Page Read, for a single plane with 8640byte page registers. Since the device is equipped with two memory planes, activating the two sets of 8640byte page registers enables a random read of two pages. Multi plane Page Read is initiated by repeating command 60h followed by three address cycles twice. In this case, only same page can be selected from each plane.

After Read Confirm command (30h) the 17280bytes of data within the selected two pages are transferred to the data registers in less than $200\mu s$ (t_R). The system controller can detect the completion of data transfer (t_R) by monitoring the output of R/B# pin.

Once the data is loaded into the data registers, the data output of first plane can be read out by issuing command 00h with Five Address Cycles, command 05h with two column address and finally E0h. The data output of second plane can be read out using the identical command sequences. The restrictions for multi plane Page Read are shown in Figure 35. multi plane Page Read must be used in the block which has been programmed with Multi plane Page Program.

■ **Figure 35. Multi plane page read**

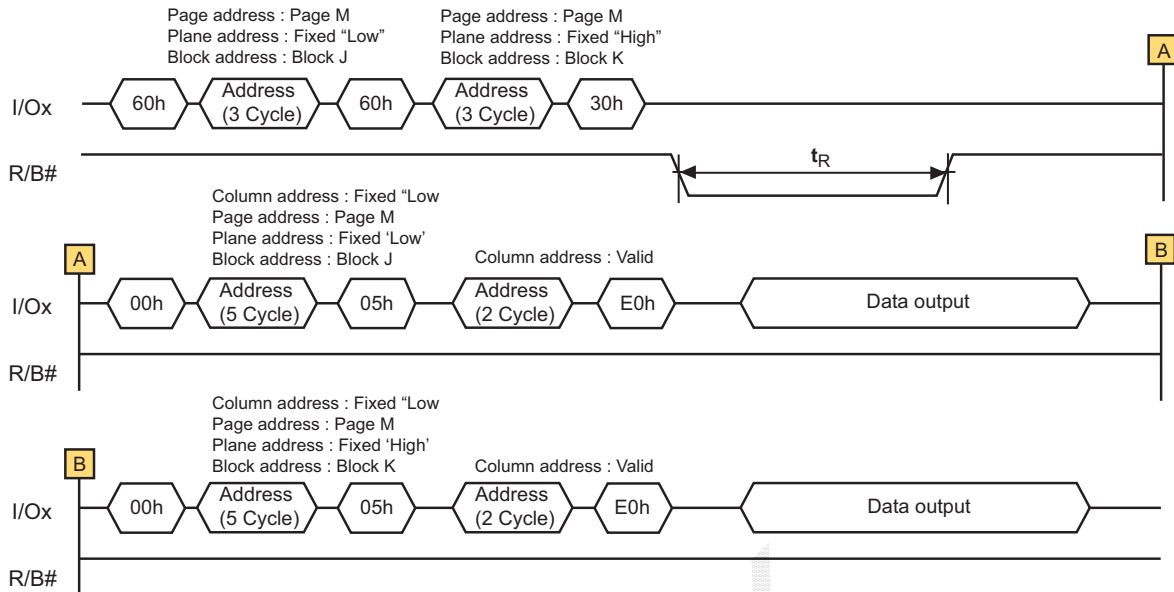

4.4. Multi Plane Cache Read (available only within a block)

The device supports multi plane cache read, which enables high read throughput by reading two pages in parallel. Figure 36 shows the command sequence for the multi plane cache read operation. Both confirm commands, 30h and 33h, are valid for the first page read sequence.

■ **Figure 36. Multi plane cache read**

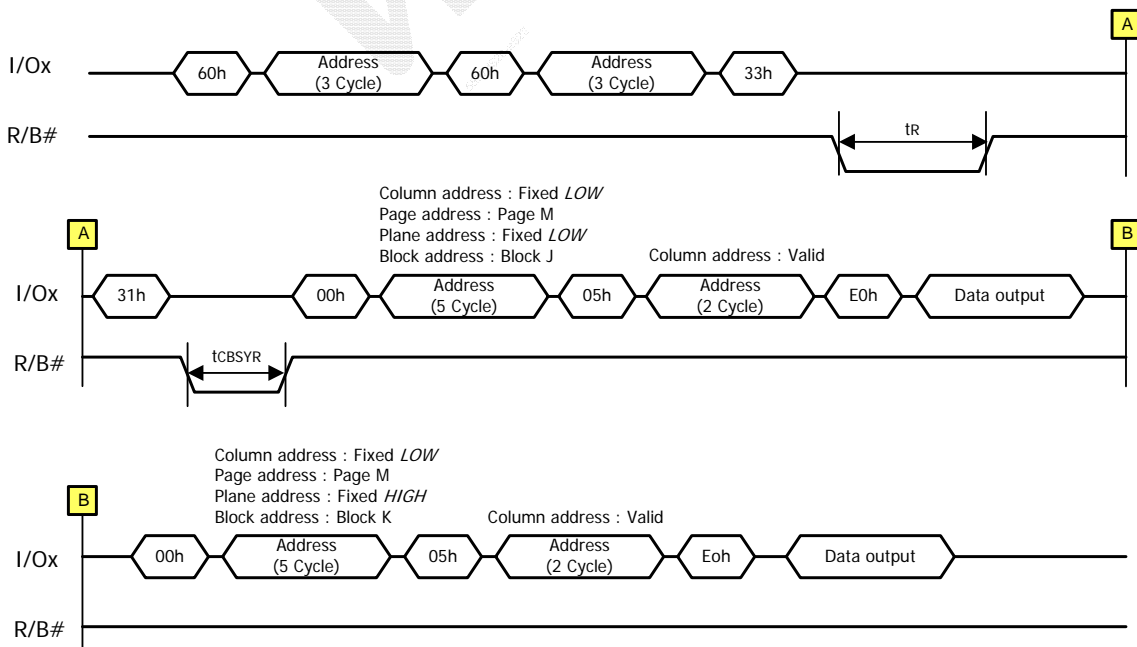

Notes:

1. Plane 0 and plane 1 should be selected within the same chip
2. Only one block should be selected from the each Plane.
3. Multi Plane cache read is available only within a block per plane.
4. Selected Page address except for A22 within two blocks must be same.
5. The operation has to be terminated with "3Fh" command.

4.5. Read ID

The device contains a product identification mode, initiated by writing 90h to the command register, followed by an address input of 00h. Six read cycles sequentially output the manufacturer code (ADh), and the device code and 3rd, 4th, 5th, 6th cycle ID, respectively. The command register remains in Read ID mode until further commands are issued to it. Figure 37 shows the operation sequence, while 2.10 READ ID data tables explain the byte meaning.

■ Figure 37. Read ID

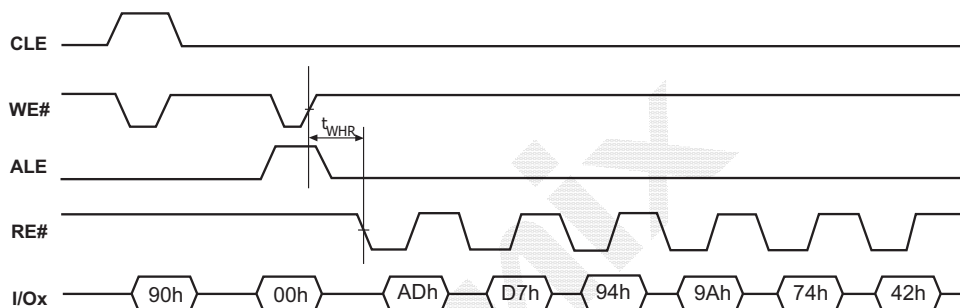

4.6. Read Status Register

The device contains a Status Register which may be read to find out whether read, program or erase operation is completed, and whether the program or erase operation is completed successfully. After writing Read Status (70h) or Multi Plane Read Status (78h) command to the command register, a read cycle outputs the content of the Status Register to the I/O pins only if CE# and RE# are low, whichever occurs last. This two line control allows the system to poll the progress of each device in multiple memory connections even when R/B# pins are common-wired. Refer to 2.8. STATUS REGISTER CODINGS for specific Status Register definitions and Figure 38, Figure 39 for Read Status. The command register remains in Read Status mode until further commands are issued to it. Therefore, if the status register is read during a random read cycle, the read command (00h) should be given before starting read cycles.

■ Figure 38. Read status

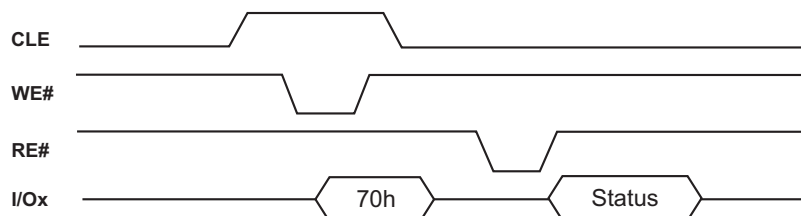

■ Figure 39. Multi plane read status

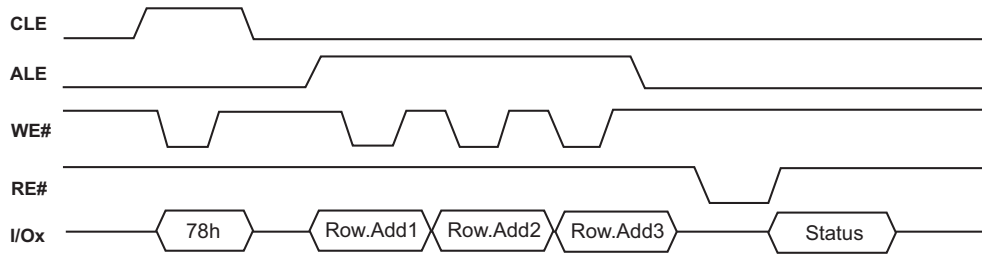

4.7. Page Program

The device is programmed as a page unit. The number of consecutive partial page programming operation within the same page without an intervening erase operation must not exceed 1 times. The program addressing should be done in sequential order in a block. A page program cycle consists of a serial data loading period in which up to 8640bytes of data may be loaded into the data register, followed by a non-volatile programming period where the loaded data is programmed into the appropriate cell. The serial data-loading period begins by inputting the Serial Data Input command (80h), followed by the five cycle address inputs and then serial data. The bytes other than those to be programmed do not need to be loaded. The device supports random data input in a page. The column address of next data, which will be entered, may be changed to the address which follows random data input command (85h). Random data input may be operated multiple times, regardless of how many times it is done in a page. The Page Program Confirm command (10h) initiates the programming process. Writing 10h alone without previously entering the serial data will not initiate the programming process. The internal write state controller automatically executes the algorithms and timings necessary for program and verify, thereby freeing the system controller for other tasks. Once the program process starts, the Read Status Register command may be entered to read the status register.

The system controller can detect the completion of a program cycle by monitoring the R/B# output, or the Status bit (I/O 6) of the Status Register. Only the Read Status command and Reset command are valid while programming is in progress. The Write Status Bit (I/O 0) is valid, when all internal operations are complete (status bit I/O 6 = high).

The internal write verify detects only errors for "1"s that are not successfully programmed to "0"s.

The command register remains in Read Status command mode until another valid command is written to the command register. Figure 40 and Figure 41 details the sequence.

■ **Figure 40. Page Program**

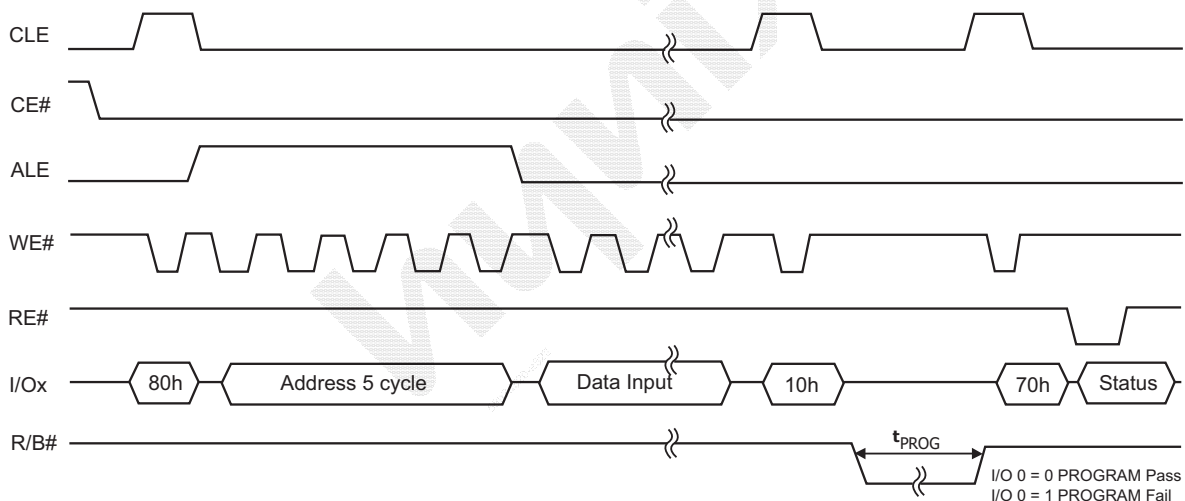

■ **Figure 41. Random data input**

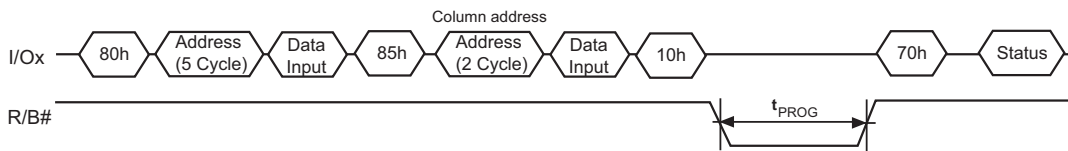

4.8. Multi Plane Program

Device supports multiple plane program. It is possible to program in parallel 2 pages, one per each plane.

A multiple plane program cycle consists of a double serial data loading period in which up to 17,280bytes of data may be loaded into the data register, followed by a non-volatile programming period where the loaded data is programmed into the appropriate cell. The serial data loading period begins by inputting the Serial Data Input command (80h), followed by the five cycle address inputs and then serial data for the 1st page. Address for this page must be within first plane ($A<22>=0$). The data of first page other than those to be programmed do not need to be loaded. The device supports random data input exactly like page program operation. The Dummy Page Program Confirm command (11h) stops 1st page data input and the device becomes busy for a short time (t_{DDBSY}). Once it has become ready again, 81h command must be issued, followed by second page address (5 cycles) and its serial data input. Address for this page must be within second plane ($A<22>=1$). The data of second page other than those to be programmed do not need to be loaded. Program Confirm command (10h) makes parallel programming of both pages start. User can check operation status by R/B# pin or read status register command, as if it were a normal page program; status register command is also available during Dummy Busy time (t_{DDBSY}). In case of fail in first plane or second plane page program, fail bit of status register will be set: Pass/Fail status of each plane can be checked by Multi Plane Read Status. Figure 42 details the sequence.

■ **Figure 42. Multi plane page program**

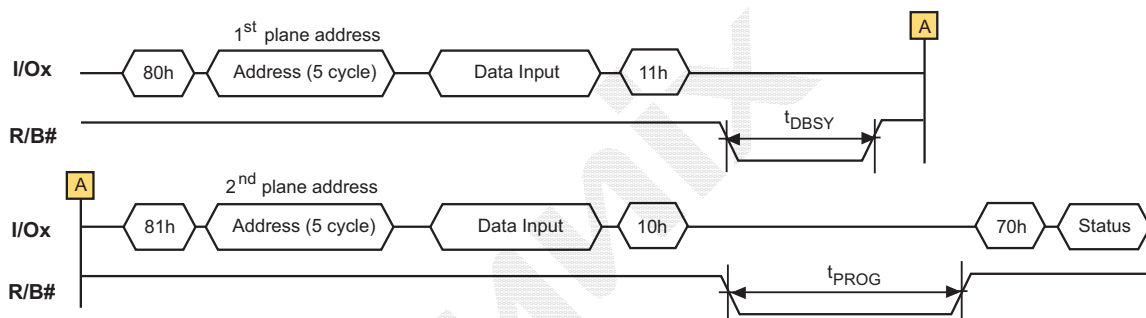

Notes:

1. Plane 0 and Plane 1 should be selected within the same chip
2. Only one block should be selected from the each Plane.
3. Selected Page address except for A22 within two blocks must be same.
4. Any command between 11h and 81h is prohibited except 70h/78h and FFh.
5. Read Status command can be 70h or 78h.

4.9. Cache Program (available only within a block)

Cache Program is an extension of the standard page program, which is executed with 8,640 bytes cache registers and same bytes data register. After the serial data input command (80h) is loaded to the command register, followed by 5 cycles of address, a full or partial page of data is latched into the cache register, and then the cache write command (15h) is loaded to the command register. After that sequence, the data in the cache register is transferred into the data register for cell programming. At this time, the device remains in busy state. After all data of the cache register is transferred into the data register, the device goes to the Ready state to load the next data into the cache register by issuing another cache program command sequence (80h-15h).

There are some restrictions for cache program operation.

1. The cache program command is available only within a block.
2. User must give address and data after 80h command.

The Busy time of first sequence equals the time it takes to transfer the data of cache register to the data register. Cell programming of the data of data register and loading of the next data into the cache register is consequently processed as a pipeline method. On the second and cascading sequence, transfer from the cache register to the data register is held off until cell programming of current data register contents has been done.

Read Status command (70h) may be issued to find out when the cache register is ready by polling the Cache-Busy sta-

tus bit (I/O 6). In addition, the status bit (I/O 5) can be used to determine when the cell programming of the current data register contents is complete. Pass/fail status of only the previous page (I/O 1) is available upon the return to Ready state.

The last page of the target programming sequence must be programmed with actual "Page Program" command (10h). If single plane cache program begins, single plane sequence should be used until single plane cache program is ended. Pass/fail status is available in two steps. I/O 1 returns with the status of the previous page upon Ready or I/O6 status bit changing to "1", and later I/O 0 with the status of current page upon true Ready (returning from internal programming) or I/O 5 status bit changing to "1". I/O 1 may be read together when I/O 0 is checked. Refer to 2.8. Status Register Coding and Figure 43 for more details.

■ **Figure 43. Cache program**

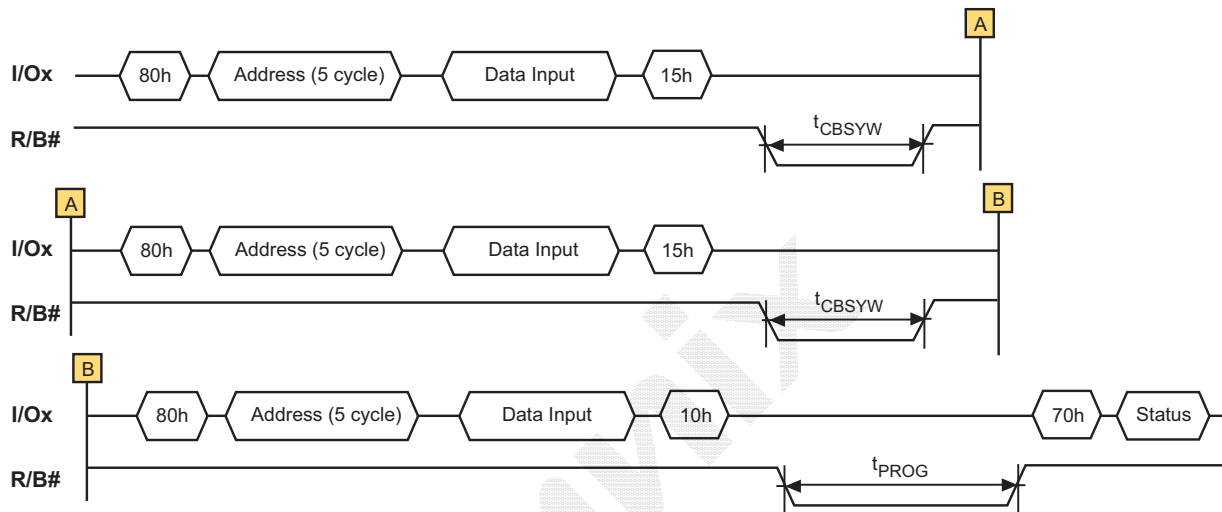

Pass / Fail status for each page programmed by the Cache Program operation can be detected by the Read Status operation.

- I/O 0 : Pass / Fail of the current page program operation.
- I/O 1 : Pass / Fail of the previous page program operation.

The Pass / Fail status on I/O 0 and I/O 1 are valid under the following conditions.

- Status on I/O 0 : Ready / Busy is Ready state.

The Ready/ Busy is output on I/O 5 by Read Status operation or R/B pin after the 10h command.

- Status on I/O 1 : Data Cache Ready / Busy is Ready State.

The Data Cache Ready / Busy is output on I/O 6 by Read Status operation or R/B pin after the 15h command.

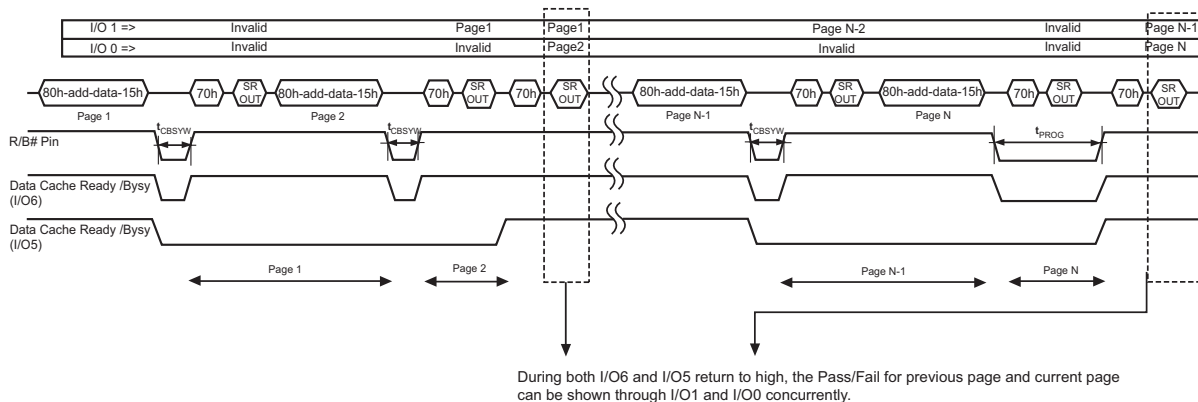

4.10. Multi Plane Cache Program (available only within a block)

The device supports multi plane cache program, which enables high program throughput by programming two pages. The serial data-loading period begins by inputting the Serial Data Input command (80h), followed by the five cycle address inputs and then serial data for the first page. Address for this page must be within first plane ($A<22>=0$). The data of first page other than those to be programmed do not need to be loaded. The device supports random data input exactly like page program operation. The Dummy Page Program Confirm command (11h) stops 1st page data input and the device becomes busy for a short time (t_{DBSY}). Once it has become ready again, 81h command must be issued, followed by 2nd page address (5 cycles) and its serial data input. Address for this page must be within second plane ($A<22>=1$). The data of second page other than those to be programmed do not need to be loaded. Cache Program Confirm command (15h) makes parallel programming of both pages start. And last page inputs Program confirm command (10h). the last page of the target programming sequence must be programmed with actual Page Program command (10h). If the operation is terminated, Issue FFh reset before next operation. If multiplane cache program begins, multiplane sequence should be used until multiplane cache program is ended. Figure 44 shows the command sequence for Multi Plane Cache Program operation. After the "15h" or "10h" command, the result per plane of the operation is shown through the "78h" Multi Plane Read Status command.

■ Figure 44. Multi plane cache program

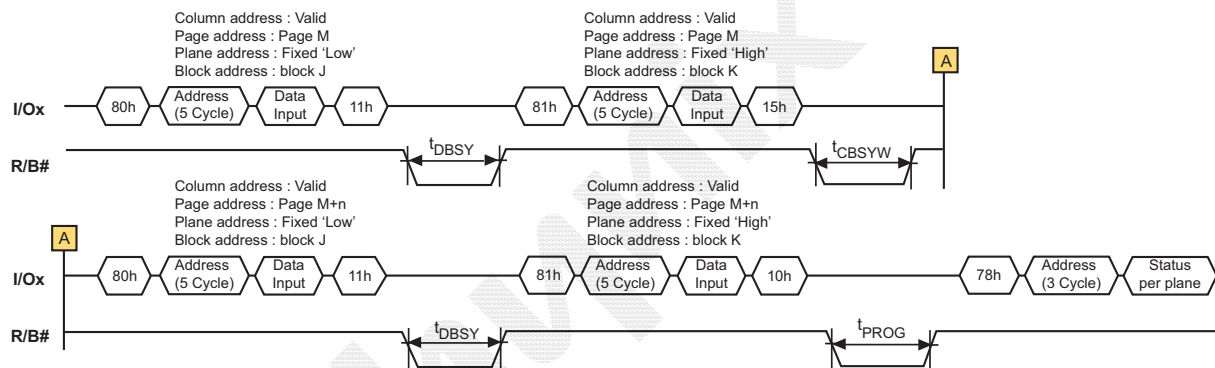

Notes:

1. Plane 0 and Plane 1 should be selected within the same chip
2. Only one block should be selected from the each Plane.
3. Multi Plane cache program is available only within a block per Plane.
4. Selected Page address except for A22 within two blocks must be same.
5. The operation has to be terminated with "10h" command."
6. Any command between 11h and 81h is prohibited except 70h/78h and FFh.
7. Read Status command can be 70h or 78h. Reading the Status per Plane is available only 78h.

4.11. Copy-Back Program

Copy-Back program with Read for Copy-Back is configured to quickly and efficiently rewrite data stored in one page without data reloading when the bit error is not in data stored. Since the time-consuming re-loading cycles are removed, the system performance is improved. The benefit is especially obvious when a portion of a block is updated and the rest of the block needs to be copied to the newly assigned free block. Copy-Back operation is a sequential execution of Read for Copy-Back and of copy-back program with the destination page address. A read operation with "35h" command and the address of the source page moves the whole 8,640-byte data into the internal data buffer. A bit error is checked by sequential reading the data output. In the case where there is no bit error, the data do not need to be reloaded. Therefore, Copy-Back program operation is initiated by issuing Page-Copy Data-Input command (85h)

with destination page address. Actual programming operation begins after Program Confirm command (10h) is issued. Once the program process starts, the Read Status Register command (70h) may be entered to read the status register. The system controller can detect the completion of a program cycle by monitoring the R/B# output, or the Status bit (I/O 6) of the Status Register. When the Copy-Back Program is complete, the Write Status Bit (I/O 0) may be checked. The command register remains in Read Status command mode until another valid command is written to the command register. During copy-back program, data modification is possible using random data input command (85h) as shown in Figure 45.

■ **Figure 45. Copyback program**

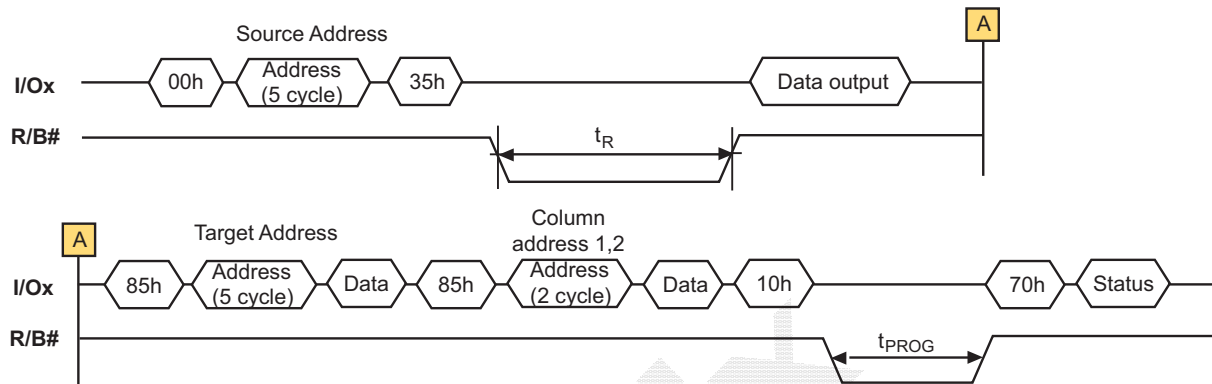

4.12. Multi Plane Copy-Back Program

Multi plane Copy-Back Program is an extension of Copy-Back Program, for a single plane with 8,640 byte page registers. Since the device is equipped with two memory planes, activating the two sets of 8,640-byte page registers enables a simultaneous programming of two pages. Figure 46 and Figure 47 show command sequence for the Multi Plane copy-back operation. First case, Figure 46, shows random data input of two planes that started right after finishing random data output of previous two planes. Second case, Figure 47, shows the random data input of each plane which started right after finishing the random data output of each Plane.

■ **Figure 46. Multi plane Copyback program**

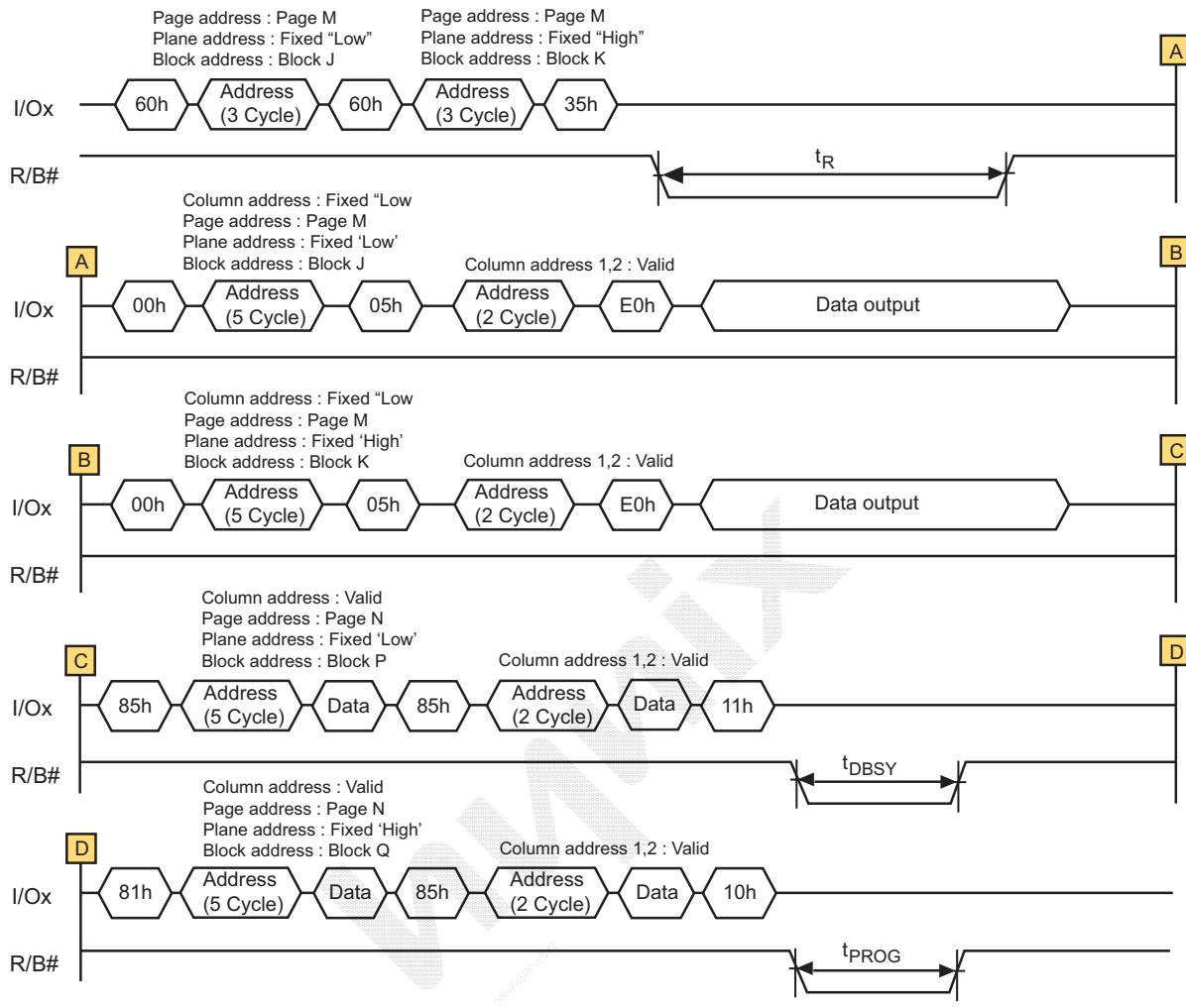

■ **Figure 47. Multi plane Copyback program**

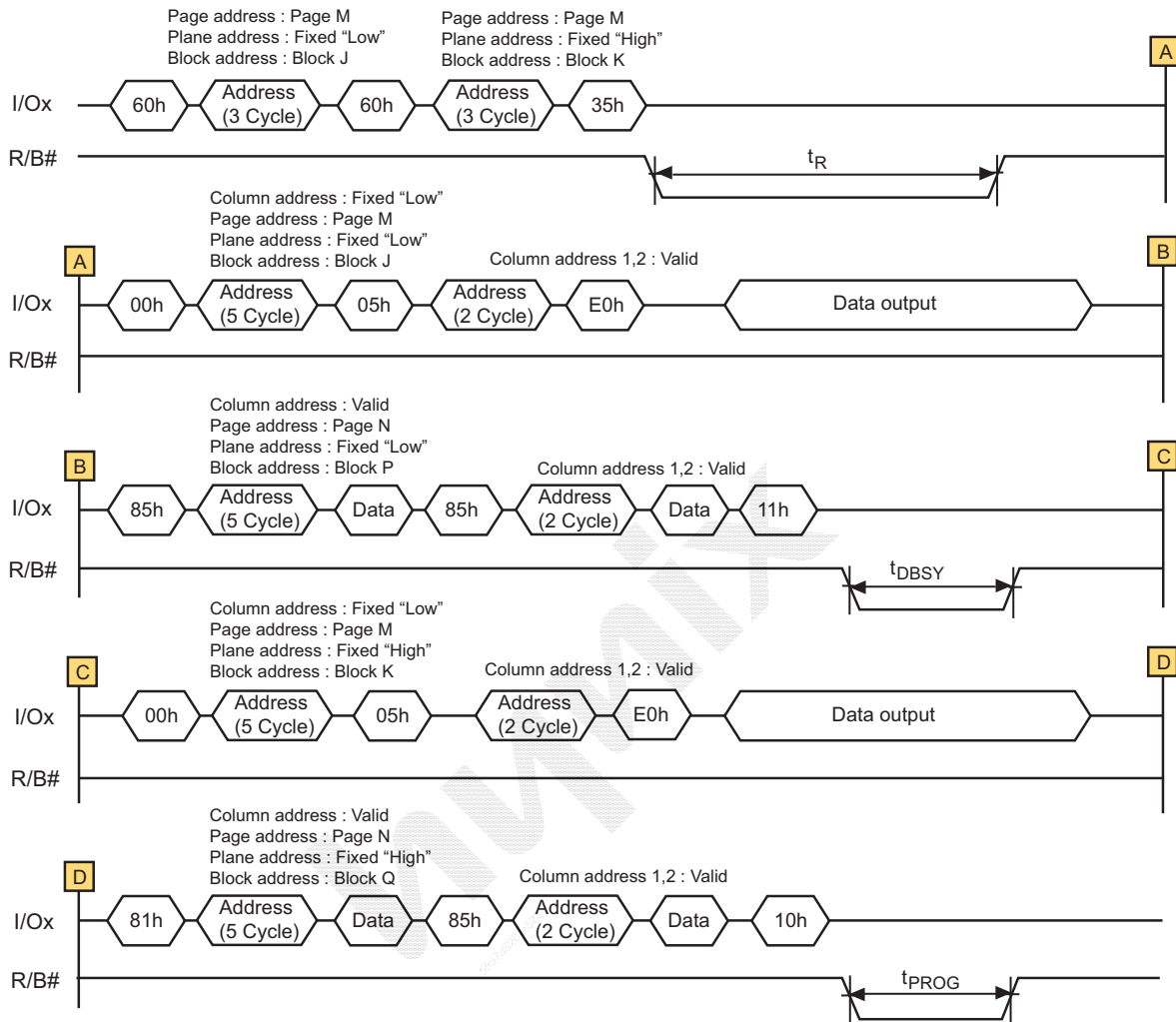

4.13. Block Erase

The Erase operation is done on a block basis. Block address loading is accomplished in two cycles initiated by an Erase Setup command (60h). Only address A22 to A31 is valid while A14 to A21 is ignored. The Erase Confirm command (D0h) following the block address loading initiates the internal erasing process. This two-step sequence of setup followed by execution command ensures that memory contents are not accidentally erased due to external noise conditions.

At the rising edge of WE# after the erase confirm command input, the internal write controller handles erase and erase verify.

Once the erase process starts, the Read Status Register command may be entered to read the status register. The sys-

tem controller can detect the completion of an erase by monitoring the R/B# output, or the Status bit (I/O 6) of the Status Register. Only the Read Status command and Reset command are valid while erasing is in progress. When the erase operation is completed, the Write Status Bit (I/O 0) may be checked. Figure 48 details the sequence.

■ **Figure 48. Block Erase**

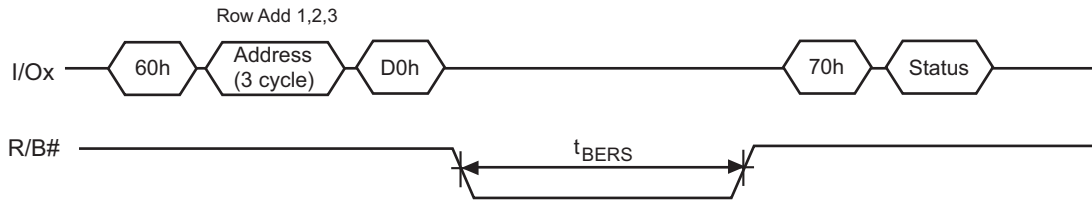

4.14. Multi Plane Block Erase

Multiple plane erase, allows parallel erase of two blocks, one per each memory plane. Block erase setup command (60h) must be repeated two times, each time followed by first block and second block address respectively (3 cycles each). As for block erase, D0h command makes embedded operation start. Multi plane erase does not need any Dummy Busy Time between first and second block address insertion. Address limitation required for Multiple Plane Program applies also to multiple plane erase, as well as operation progress can be checked like for Multiple Plane Program. Refer to the detail sequence as shown below.

■ **Figure 49. Multi plane Block Erase**

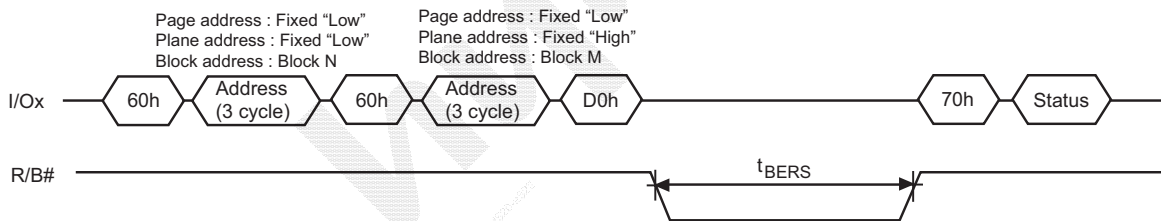

4.15. Reset

The device offers a reset feature, executed by writing FFh to the command register. When the device is in Busy state during random read, program or erase mode, the reset operation will abort these operations. The contents of memory cells being altered are no longer valid, as the data will be partially programmed or erased. The command register is cleared to wait for the next command, and the Status Register is cleared to value E0h when WP# is high. Refer to 2.8. Status Register Coding for device status after reset operation. If the device is already in reset state, the command register will not accept a new reset command. The R/B# pin goes low for t_{RST} after the Reset command is written. Refer to Figure 50.

■ Figure 50. Reset

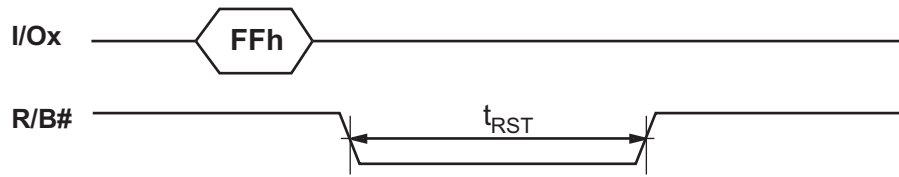

hynix

5. INTERLEAVED OPERATION

Interleaving operations improve the system throughput compared to non-interleaving operations. In the stacked device sharing a common CE# pin, interleaved operation is available. When both chip are ready state, input a command to the chip #1. And then, while chip #1 is busy state, issue a command to the other chip. When performing interleaved operations, the operations shall be the same type. The functions that may be used in the interleaved operations are Page Read, Page Program, Block Erase, Multi Plane Page Read, Multi Plane Page Program, and Multi Plane Block Erase. During interleaved operations, 70h command is prohibited exceptionally. Each chip status can be checked by Multi Plane Read Status Command (78h). The R/B# pin shows when both chip are Ready or Busy. While either chip is busy, R/B# pin is low. All chips are Ready state and interleaved operations are complete, R/B# pin goes high. Cache function and Copyback function are impossible for interleaved operation.

5.1. Interleaved Page Read

Figure 51 shows how to perform interleaved PAGE READ operations. In Figure, the status register is monitored for operation completion with the Multi plane status read (78h) command. When the host has issued Page Read commands to multiple die at the same time, the host shall issue Multi plane status read (78h) command before reading data from either die. This ensures that only the die selected by the 78h command responds to a data output cycle after being put in data output mode with a 00h command, and thus avoiding bus contention. The host can use 78h commands to read out data from another die.

■ **Figure 51. Interleaved page read**

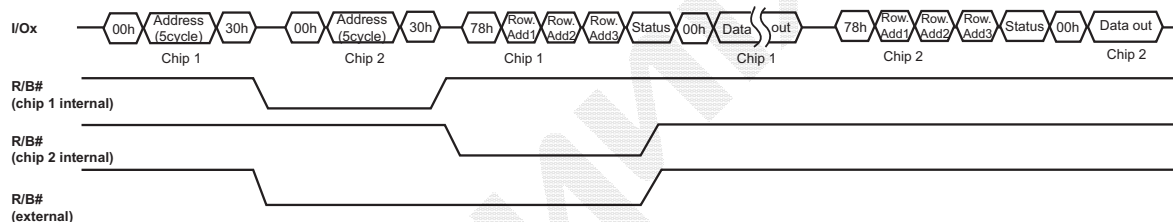

Note:
 70h command is prohibited during interleaved operations.

5.2. Interleaved Multi Plane Page Read

Figure 52 shows how to perform interleaved Multi Plane Page Read operations using the Multi plane read status (78h) command to monitor the status register for operation completion. When the host has issued Multi Plane Page Read commands to multiple die at the same time, the host shall issue Multi plane read status (78h) command before reading data from either die. This ensures that only the die selected by the 78h command responds to a data output cycle after being put in data output mode with a 00h command and 5 address cycles, and thus avoiding bus contention. The interleaved Multi plane page read operation must meet two-plane addressing requirements.

■ **Figure 52. Interleaved multi plane page read**

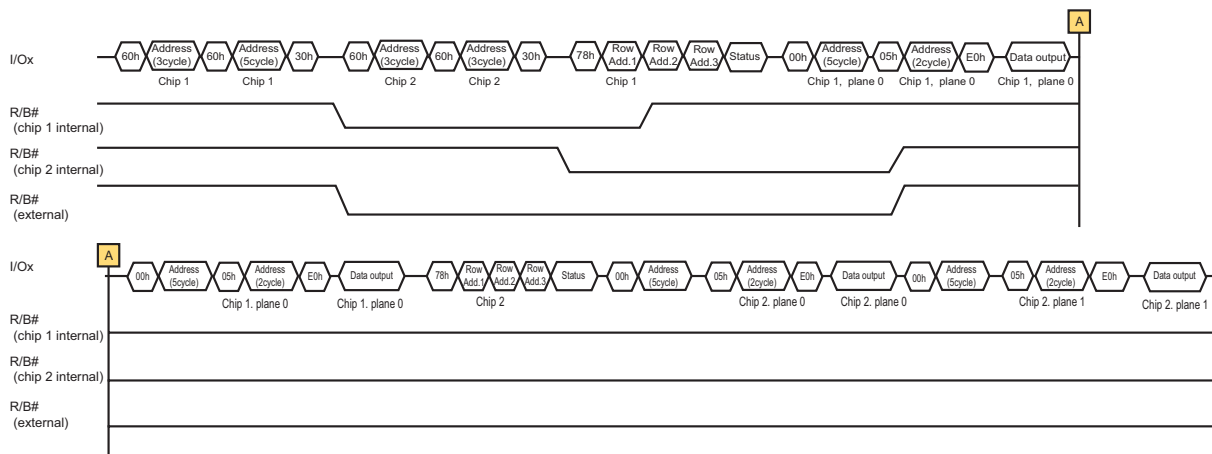

Note:
 70h command is prohibited during interleaved operations.

5.3. Interleaved Page Program

Figure 53 show how to perform interleaved PROGRAM PAGE operations. RANDOM DATA INPUT (85h) is permitted during interleaved PROGRAM PAGE operations.

■ **Figure 53. Interleaved page program**

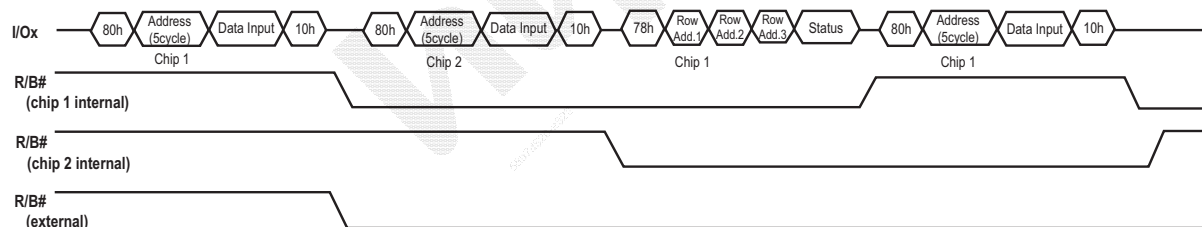

Note:
 70h command is prohibited during interleaved operations.

5.4. Interleaved Multi Plane Page Program

Figure 54 shows how to perform interleaved Multi Plane Page Program operations. The interleaved TWO-PLANE PROGRAM PAGE operation must meet two-plane addressing requirements. Random data input (85h) is permitted during interleaved Multi plane page program operation.

■ **Figure 54. Interleaved multi plane page program**

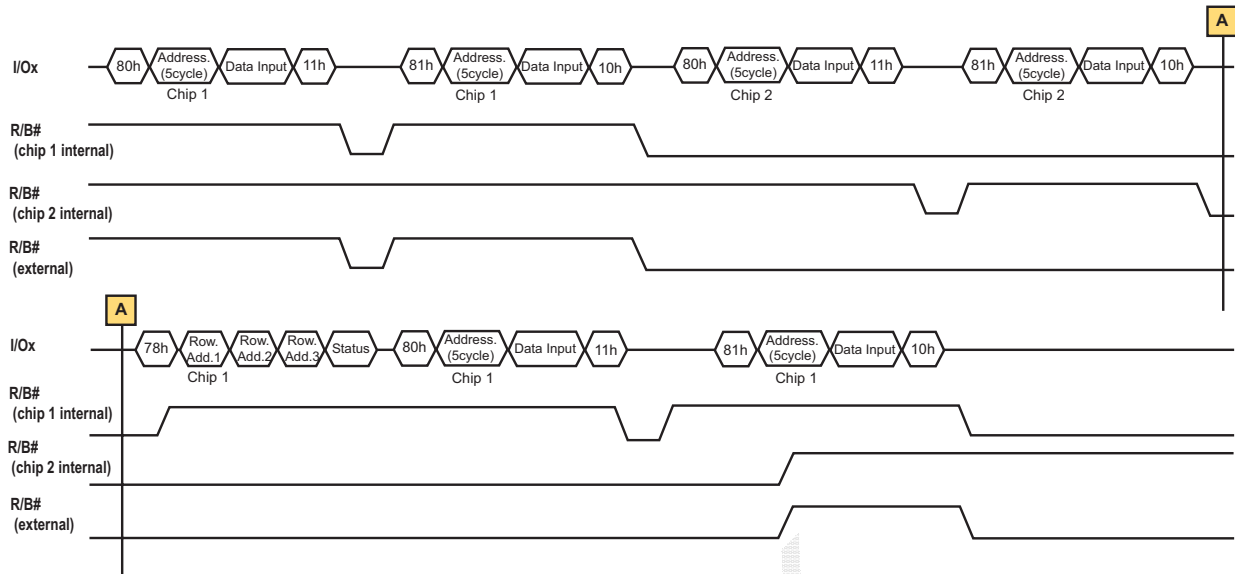

Note:
 70h command is prohibited during interleaved operations.

5.5. Interleaved Block Erase

Figure 55 shows how to perform interleaved Block Erase operation.

■ **Figure 55. Interleaved block erase**

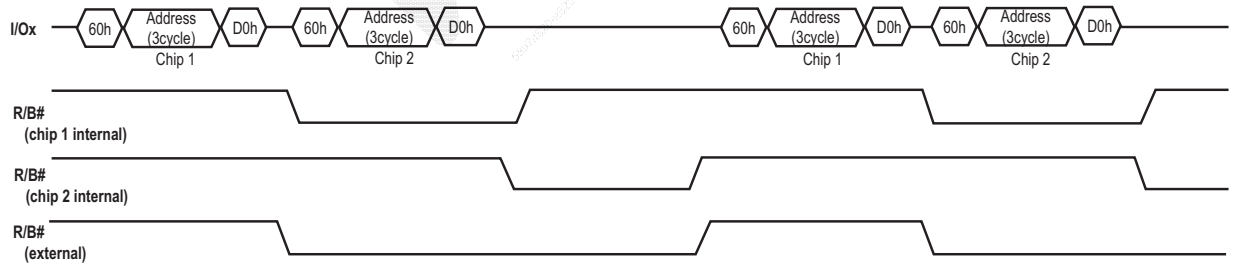

Note:
 70h command is prohibited during interleaved operations.

5.6. Interleaved Multi Plane Block Erase

Figure 56 shows how to perform two types of interleaved Multi Plane Block Erase operations. This operation must meet two-plane addressing requirements.

■ **Figure 56. Interleaved multi plane block erase**

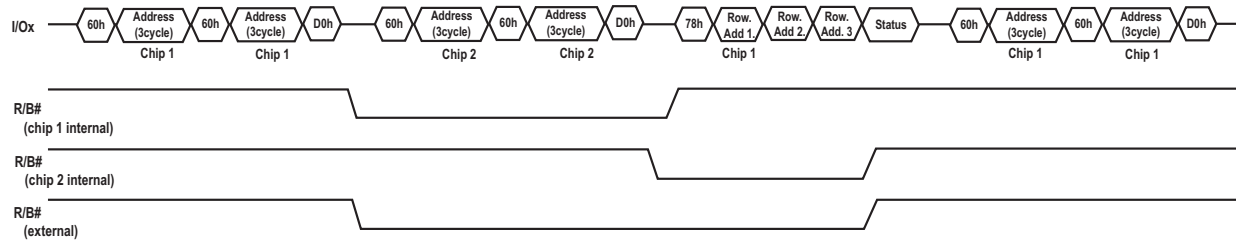

Note:
 70h command is prohibited during interleaved operations.



6. OTHER FEATURES

6.1. Data Protection & Power on/off Sequence

The device is designed to offer protection from any involuntary program/erase during power-transitions. An internal voltage detector disables all functions whenever V_{CC} is below about 2.0V (3.3V device). WP# pin provides hardware protection and is recommended to be kept at VIL during power-up and power-down. The reset command (FFh) must be issued to all dies as the first command after device is power up. Each R/B# will be busy for maximum of 2ms after reset command is issued. In this time, the acceptable command is 70h or 78h.

■ **Figure 57. Data protection and power on / off**

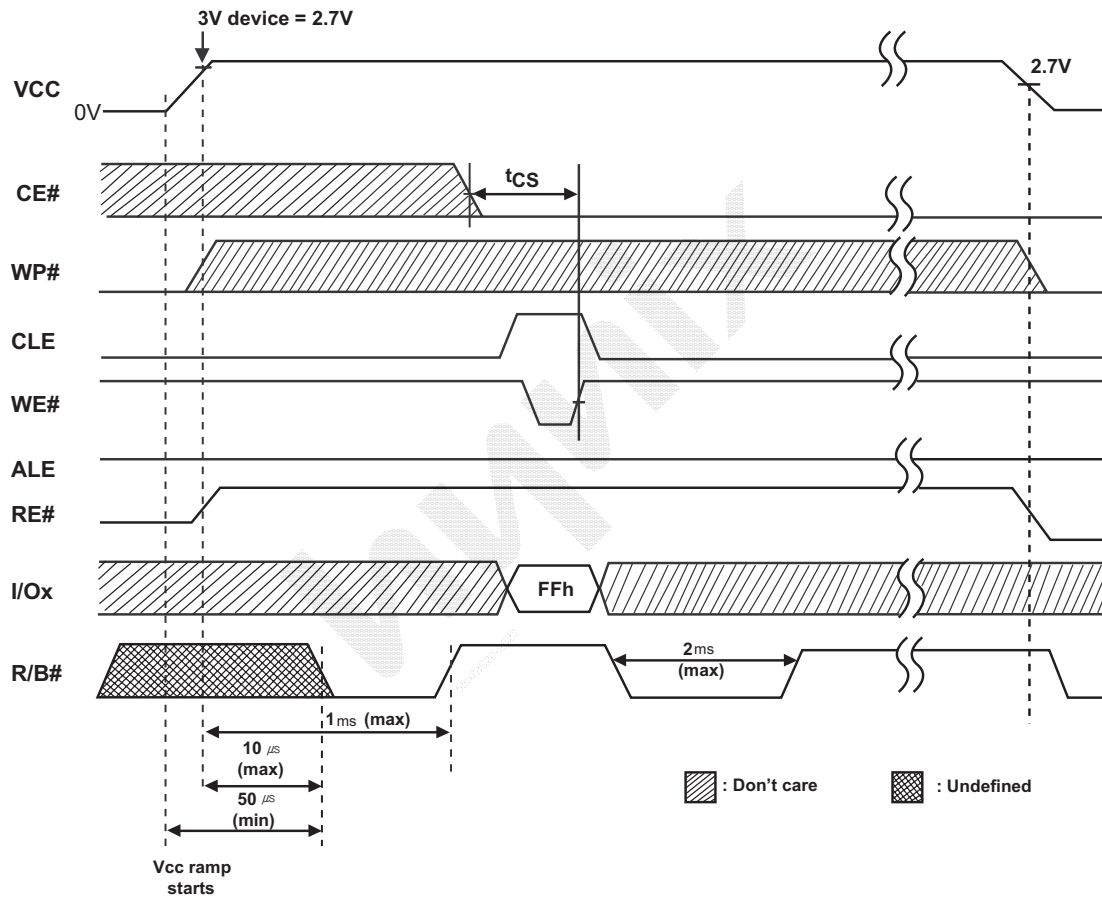

6.2. Ready / Busy

The device has a Ready/Busy output that provides method of indicating the completion of a page program, erase, copy-back and random read completion. The R/B# pin is normally high and goes to low when the device is busy (after a reset, read, program, and erase operation). It returns to high when the internal controller has finished the operation. The pin is an open-drain driver thereby allowing two or more R/B# outputs to be Or-tied. Because pull-up resistor value is related to t_R (R/B#) and current drain during busy (I_{busy}), an appropriate value can be obtained with the following reference chart (Figure 58). Its value can be determined by the following guidance.

■ Figure 58. Ready / Busy

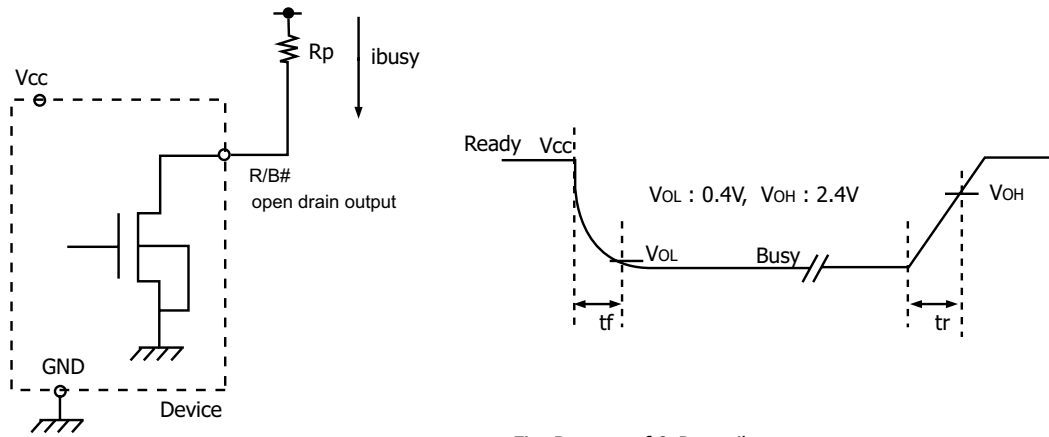
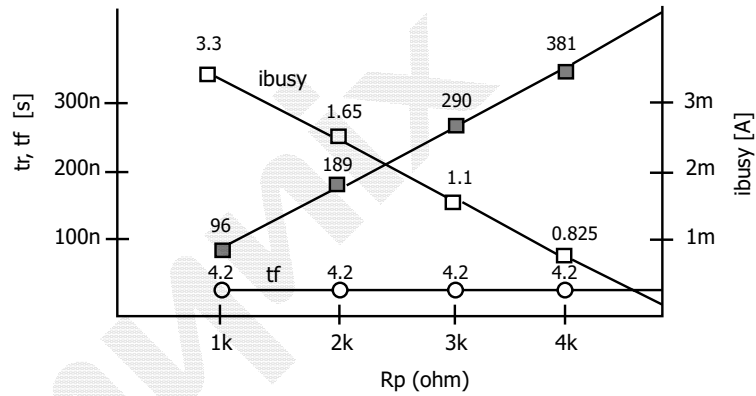

Fig. Rp vs tr, tf & Rp vs ibusy

@ Vcc = 3.3V, Ta = 25°C, CL=50pF



Rp value guidance

$$R_p (\text{min}) = \frac{V_{cc} (\text{Max.}) - V_{oL} (\text{Max.})}{I_{oL} + \sum I_L} = \frac{3.2V}{8\text{mA} + \sum I_L}$$

where IL is the sum of the input current of all devices tied to the R/B# pin.

Rp(max) is determined by maximum permissible limit of tr

6.3. Write Protect Operation

The Erase and Program Operations are automatically reset when WP# goes Low ($t_{WW} = 100\text{ns, min}$). The operations are enabled and disabled as follows (Figure 59 ~ 62).

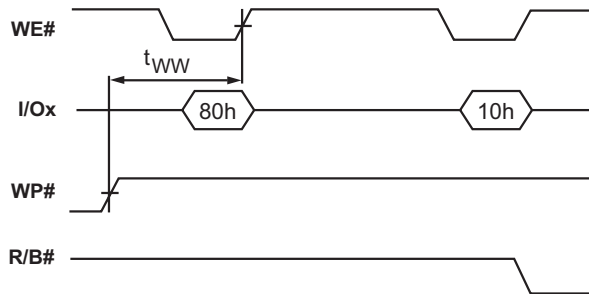

Figure 59. Enable Programming

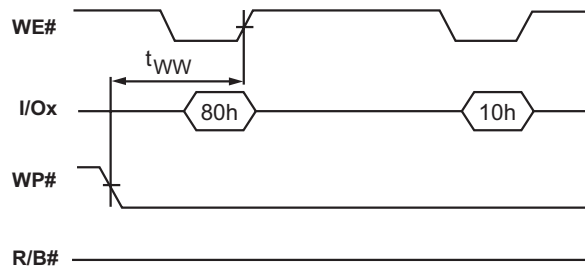

Figure 60. Disable Programming

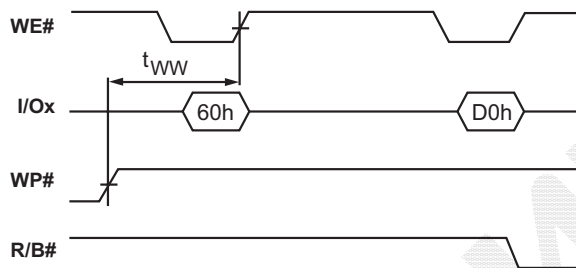

Figure 61. Enable Erasing

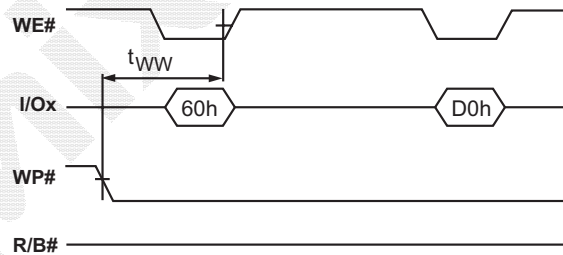

Figure 62. Disable Erasing

7. Application Notes and Comments

7.1. Paired Page Address Information

Paired page address		Paired page address	
0	4	1	5
2	8	3	9
6	C	7	D
A	10	B	11
E	14	F	15
12	18	13	19
16	1C	17	1D
1A	20	1B	21
1E	24	1F	25
22	28	23	29
26	2C	27	2D
2A	30	2B	31
2E	34	2F	35
32	38	33	39
36	3C	37	3D
3A	40	3B	41
3E	44	3F	45
42	48	43	49
46	4C	47	4D
4A	50	4B	51
4E	54	4F	55
52	58	53	59
56	5C	57	5D
5A	60	5B	61
5E	64	5F	65
62	68	63	69
66	6C	67	6D
6A	70	6B	71
6E	74	6F	75
72	78	73	79
76	7C	77	7D
7A	80	7B	81
7E	84	7F	85
82	88	83	89
86	8C	87	8D
8A	90	8B	91
8E	94	8F	95
92	98	93	99
96	9C	97	9D
9A	A0	9B	A1
9E	A4	9F	A5
A2	A8	A3	A9
A6	AC	A7	AD
AA	B0	AB	B1
AE	B4	AF	B5
B2	B8	B3	B9
B6	BC	B7	BD
BA	C0	BB	C1
BE	C4	BF	C5
C2	C8	C3	C9
C6	CC	C7	CD
CA	D0	CB	D1
CE	D4	CF	D5

D2	D8	D3	D9
D6	DC	D7	DD
DA	E0	DB	E1
DE	E4	DF	E5
E2	E8	E3	E9
E6	EC	E7	ED
EA	F0	EB	F1
EE	F4	EF	F5
F2	F8	F3	F9
F6	FC	F7	FD
FA	FE	FB	FF

When program operation is abnormally aborted (ex. power-down, reset), not only page data under program but also a coupled row paired page data may be damaged. For example, during Page Program operation of page address 05h is aborted by reset or power down, the data of 00h, 01h, 04h, and 05h page address may be spoiled.

7.2. Extra Block Description

Device includes extra features like user OTP, Unique ID and Read ID2. User OTP, Unique ID can be programmed only once and cannot be erased. The user OTP used one block which locates the second block of plane 0 (address<31:22> = 0002h). Unique ID block has 64 pages, locates the first block of plane 0 and the first 64 pages of the block (address<32:22> = 0000h, address<21:14> = 00h ~ 3Fh). Read ID2 can be only read, the size is one page. Physically, ReadID2 area exists in plane1, but user block address does not care internally. To exit extra features, 07h or FFh command can be used.

7.3. Acceptable Command after 80h

After Program Start Command (80h) is inputted, do not input any command except 85h, 10h, 11h, 15h, and FFh. If a command is inputted except these commands, the program operation cannot be executed.

7.4. Acceptable Command between Start command and Confirm command

Only Reset Command is available between start commands and confirm commands set (start command-address-confirm command style) that is mentioned in 1.7 Command Set. If other command is inputted, the operation cannot be executed. Do not input any commands except FFh. For instance, it is impossible to perform a normal Page Read operation, if any command is inputted between Page Read Command Set (00h - 5 address cycle - 30h).

7.5. Restriction of Read Status Value in Multi Plane Operation

During Multi plane operation, only 70h, 78h, and FFh are available between 11h-81h. But, the pass/fail output information of 70h and 78h is not valid. During this time, only ready / busy (I/O6 and I/O5) state can be checked. Refer to Figure 63.

■ Figure 63. Restriction read status in multi plane operation

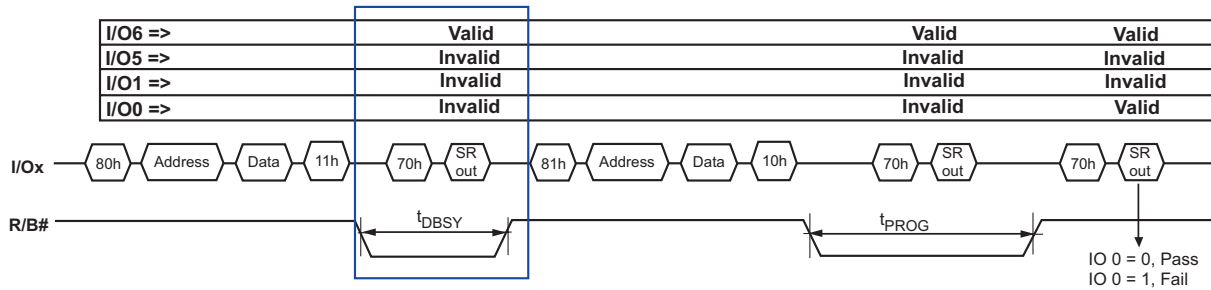

7.6. Page Program Failure

If the Page Program operation for page address N is fail, remain data in data register may be different to input data by host. Therefore, do not attempt to program the page address N in another block without the data input sequence. The same input sequence of 80h command, address and data is necessary.

7.7. Restriction Multi Plane Operation

To prevent abnormal multi plane operation, do not input bad block address to all Multi Plane Operation. Otherwise, the input data of valid block could be lost and the operation could be abnormally stopped.