

ASDL-6620

Silicon NPN Phototransistor in T-1 Package



Data Sheet

Description

ASDL-6620 is a silicon phototransistor in a standard T-1 package with options of clear and dark package. It has high sensitivity, fast response time and low dark current. Collector is denoted by a flat on the packaging diagram and the shorter of the two leads. This device matches with infrared emitter ASDL-4671 and is ideal for low cost, high volume applications.

Features

- T-1 package
- Option of Dark Lens that remove visible light
- Option of Clear Lens
- High Speed
- High Sensitivity
- Narrow Viewing Angle

Applications

- Suitable for detectors of Infrared Applications
- Smoke Detector
- Alarm System
- Photo Interrupter
- Industrial Equipment

Ordering Information

Part Number	Lead Form	Color	Packaging	Shipping Option
ASDL-6620-C22	Straight	Clear	Tape & Reel	4000pcs
ASDL-6620-C31			Bulk	8000pcs / Carton
ASDL-6620-D22		Dark	Tape & Reel	4000pcs
ASDL-6620-D31			Bulk	8000pcs / Carton

Package Dimensions

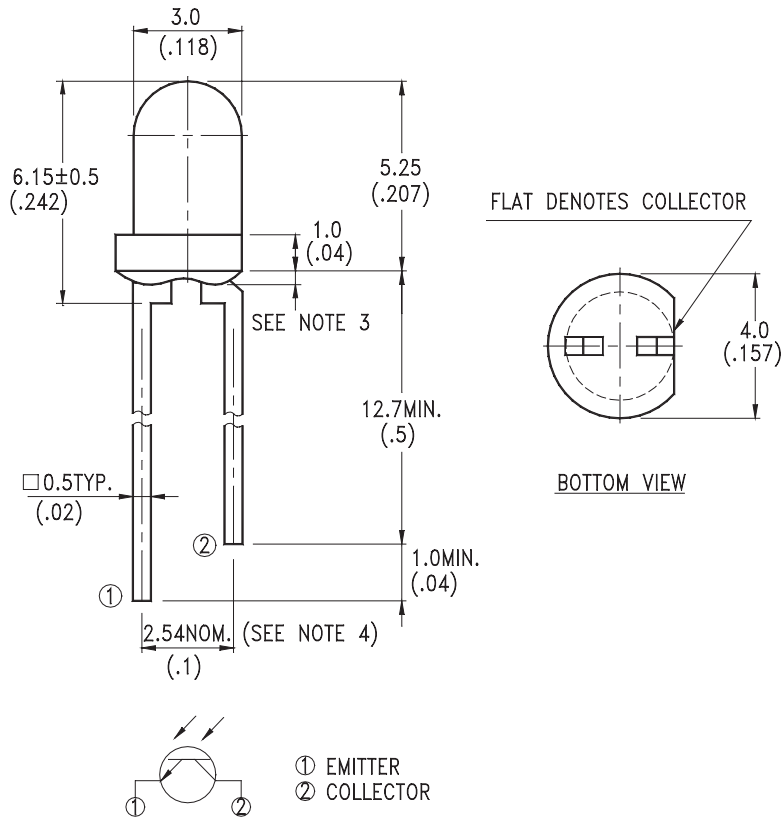

Notes:

1. All dimensions are in millimeters (inches)
2. Tolerance is + 0.25mm (.010") unless otherwise noted
3. Protruded resin under flange is 1.5mm (.059") max
4. Lead spacing is measured where leads emerge from package
5. Specifications are subject to change without notice.

Absolute Maximum Ratings at $T_A=25^{\circ}\text{C}$

Parameter	Symbol	Min.	Max	Unit
Power Dissipation	P_{DISS}		100	mW
Collector Emitter Voltage	V_{CEO}		30	V
Emitter Collector Voltage	V_{ECO}		5	V
Operating Temperature	T_0	-40	85	$^{\circ}\text{C}$
Storage Temperature	T_S	-55	100	$^{\circ}\text{C}$
Junction temperature	T_J		110	$^{\circ}\text{C}$
Lead Soldering Temperature [.6mm (0.063") From Body]		260 $^{\circ}\text{C}$ for 5 seconds	$^{\circ}\text{C}$	

Electrical Characteristics at 25°C

Parameter	Symbol	Min.	Typ.	Max.	Unit	Condition
Collector-Emitter Breakdown Voltage	$V_{(BR)CEO}$	30			V	$I_C = 1\text{mA}$ $E_e = 0\text{mW/cm}^2$
Emitter-Collector Breakdown Voltage	$V_{(BR)ECO}$	5			V	$I_e = 100\mu\text{A}$ $E_e = 0\text{mW/cm}^2$
Collector Emitter Saturation Voltage	$V_{CE(SAT)}$			0.4	V	$I_e = 0.5\text{mA}$ $E_e = 1\text{mW/cm}^2$
Collector Dark Current	I_{CEO}			100	nA	$V_{CE} = 10\text{V}$ $E_e = 0\text{mW/cm}^2$
Thermal Resistance, Junction to Pin	$R_{\theta JP}$		350		$^{\circ}\text{C/W}$	

Optical Characteristics at 25°C

Parameter	Symbol	Min.	Typ.	Max.	Unit	Condition
Viewing Angle	$2\theta_{1/2}$		20		Deg	
Wavelength of Peak sensitivity	λ_{PK}		900		nm	
Spectral BandWidth	$\Delta\lambda$	400	900	1100	nm	Clear
		700	900	1100	nm	Dark
Rise Time	t_r		10		μs	$V_{CC} = 5\text{V}$ $I_C = 1\text{mA}$ $R_L = 1\text{K}\Omega$
Fall Time	t_f		10		μs	$V_{CC} = 5\text{V}$ $I_C = 1\text{mA}$ $R_L = 1\text{K}\Omega$
On State Collector Current	$I_{C(ON)}$	1.6		9.6	mA	$V_{CE} = 5\text{V}$ $E_e = 1\text{mW/cm}^2$ $\lambda = 940\text{nm}$

Typical Electrical/Optical Characteristics Curves ($T_A=25^\circ\text{C}$ unless otherwise indicated)

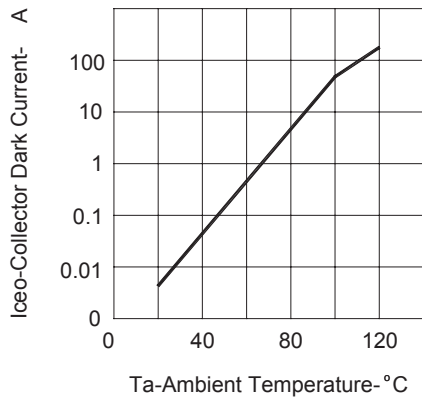

FIGURE 1. COLLECTOR DARK CURRENT VS AMBIENT TEMPERATURE

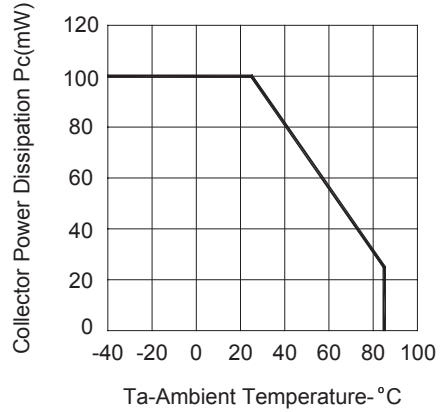

FIGURE 2. COLLECTOR POWER DISSIPATION VS AMBIENT TEMPERATURE

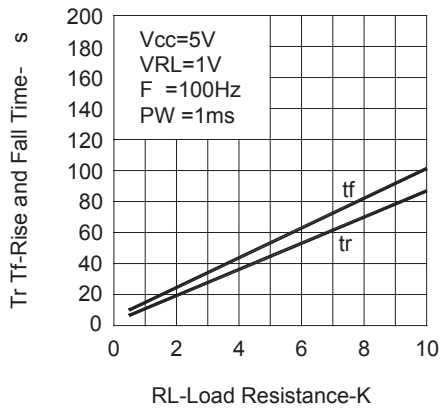

FIGURE 3. RISE AND FALL TIME VS LOAD RESISTANCE

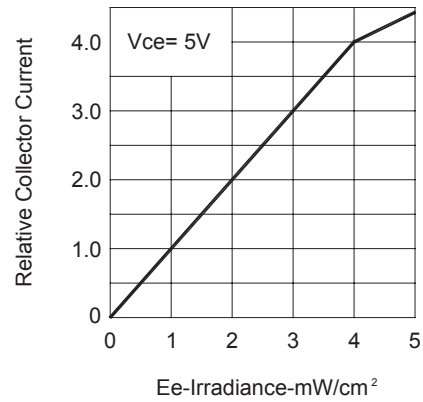

FIGURE 4. RELATIVE COLLECTOR CURRENT VS IRRADIANCE

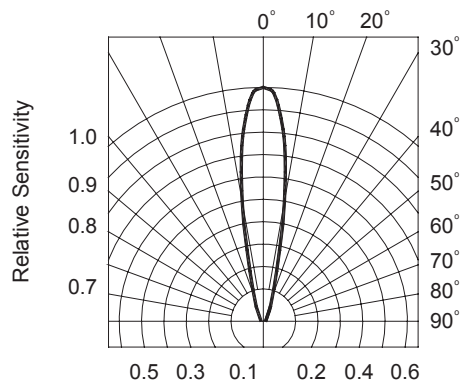

FIGURE 5. SENSITIVITY DIAGRAM

For company and product information, please go to our web site: www.liteon.com or <http://optodatabook.liteon.com/databook/databook.aspx>

Data subject to change. Copyright © 2007 Lite-On Technology Corporation. All rights reserved.

