

ISDN S-INTERFACE MODULES

Surface Mount, Dual, 1500 Vrms

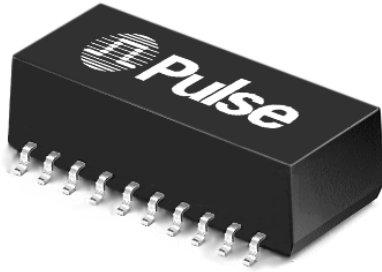

NEW!



- Meets the pulse waveform template of CCITT I.430 when recommended transformer and chip pair are used
- Developed for enhanced EMC performance
- Excellent longitudinal balance
- Transfer molded package
- Low or high frequency choke options available

Electrical Specifications @ 25°C — Operating Temperature 0°C to 70°C

Part Number	Transformer							Choke		ΔI_{bc} (mA MAX)	Secondary Pins
	Ratio $\pm 2\%$ (Pri:Sec)	OCL Pri (mH MIN)	L_L Sec (μ H MAX)	C_{ww} (pF MAX)	CD Pri (pF MAX)	DCR Pri (Ω +25% MAX)	DCR Sec (Ω +25% MAX)	OCL	DCR (Ω MAX)		
T5034	1CT:2CT	30	10	150	100	3.4	5.4	4.7 mH	1.4	3	20-18, 13-11
T5037	1CT:2.5CT	30	10	150	100	3.4	7.0	4.7 mH	1.4	3	20-18, 13-11
T5038	1CT:2CT	30	10	150	100	3.4	5.4	470 μ H	1.4	3	20-18, 13-11
T5039	1CT:2.5CT	30	10	150	100	3.4	7.0	470 μ H	1.4	3	20-18, 13-11
T5049	1CT:1CT	30	10	150	100	3.4	3.4	4.7 mH	1.4	3	20-18, 13-11

NOTE: Optional Tape & Reel packaging can be ordered by adding a "T" suffix to the part number (ex: T5034T).

Mechanical

Schematic

CEZ

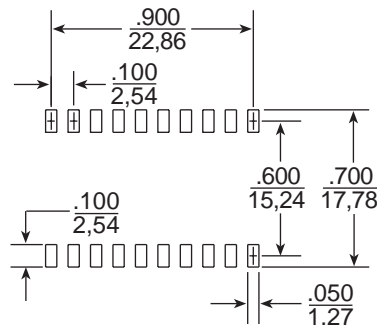
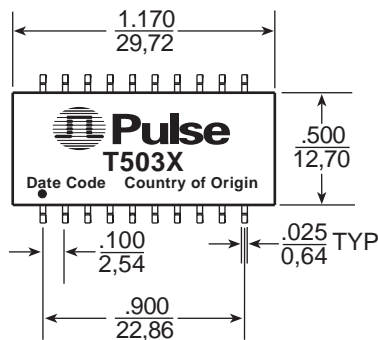

SUGGESTED PAD LAYOUT

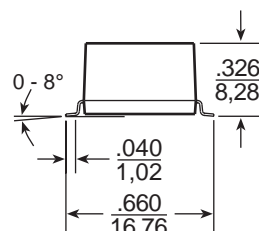
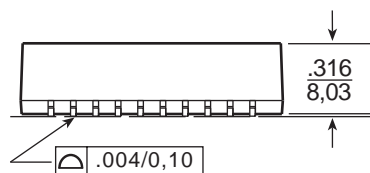
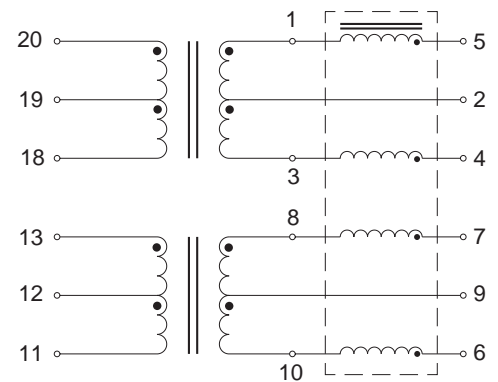

Weight 6.94 grams
Tape & Reel250/reel
Tube15/tube

Dimensions: Inches
mm

Unless otherwise specified, all tolerances are $\pm \frac{.010}{0.25}$

U.S.A: TEL 619 674 8100 • EUROPE: TEL 44 1483 401700 • ASIA: TEL 886 7 821 3141 • WEB: <http://www.pulseeng.com>

T635.B (10/98)

ISDN S-INTERFACE MODULES

Surface Mount, Dual, 1500 Vrms



Module Selection Guide

IC Manufacturer	IC Part Number	Pulse Part Number
AMD	AM79C 30A/32A	T5034/T5038
Lucent (AT&T)	T7234/T7254/T7250/T7256/T7259 T7903	T5037/T5039 T5034/T5038
Mietec	MTC-2072	T5034/T5038
Mitel	MT8930/8931	T5034/T5038
Motorola	MC145574	T5037/T5039
National	TP3420/3421	T5034/T5038
SGS Thomson	ST5420/5421	T5034/T5038
Siemens	PEB2080/2081/2084/2085/2086 PSB 2186 PSB 21381/21382/21383/21384	T5034/T5038 T5049
Yamaha	YM7405B	T5034/T5038

Definition of Terms

Ratio: This is the turns ratio, expressed as "Primary:Secondary". The term "CT" designates a center tapped winding.

OCL: Open Circuit Inductance, measured 20 KHz, 100 mV.

L_{L Sec}: Leakage Inductance measured across the primary with the respective secondary winding short circuited.

C_{ww}: Winding capacitance, formed by the primary and secondary wire. These wires form the "Plates" of this capacitor. Measured at 100 KHz, 20 mV.

CD Pri: This is the distributed capacitance.

DCR: This is the resistance of the windings when measured in DC conditions.

Δ I_{DC}: The maximum specified unbalanced DC current capability of the device.

The minimum primary inductance and the maximum distributed capacitance satisfy the transmitter output and receiver input impedance requirements of CCITT I.430 for both TE and NT.

The maximum distributed capacitance allows sufficient margin for the capacitance of the IC and a protection diode network. It is consistent with the overall maximum value specified and permitted length of the basic access TE cord.

Flammability – Materials used in the products are recognized UL94-VO. Products meet the requirements of IEC 695-2-2 (needle flame test).

ISDN S-INTERFACE MODULES

Surface Mount, Dual, 1500 Vrms



Application Notes

The S-Interface is the standardized four wire digital telephone access point defined by the CCITT I-Series recommendations for the Integrated Service Digital Network. This "basic rate access" accommodates two 64 Kbps "B-channels" for information, one 16 Kbps "D-channel" intended for signaling and

control, and 48 Kbps for framing and other purposes, giving a total rate of 192 Kbps. The CCITT physical layer recommends that the user network interface be transformer coupled as shown in our typical application notes.

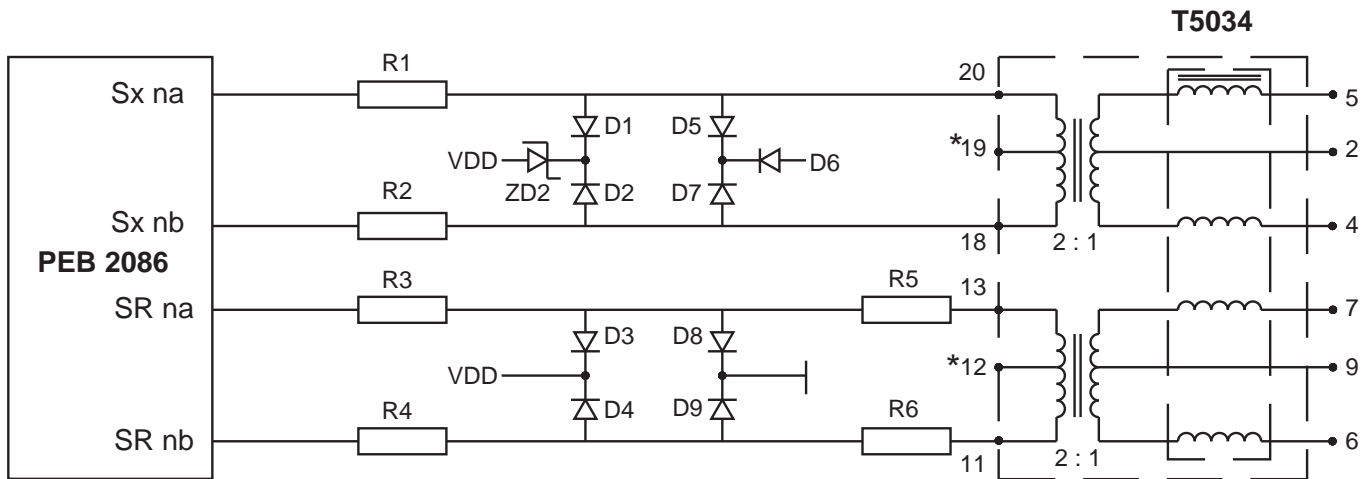

Figure 1 – Typical S-Interface Application Circuit for Siemens PEB 2086

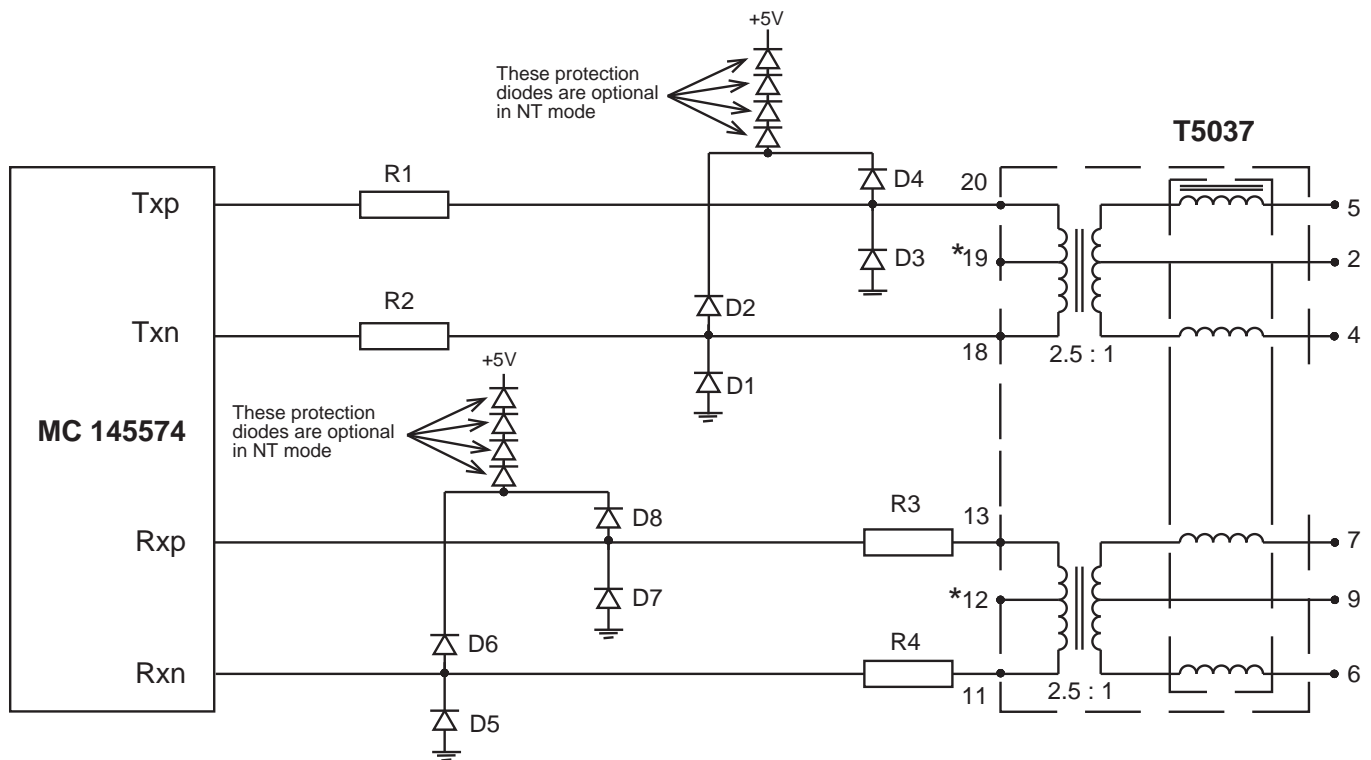
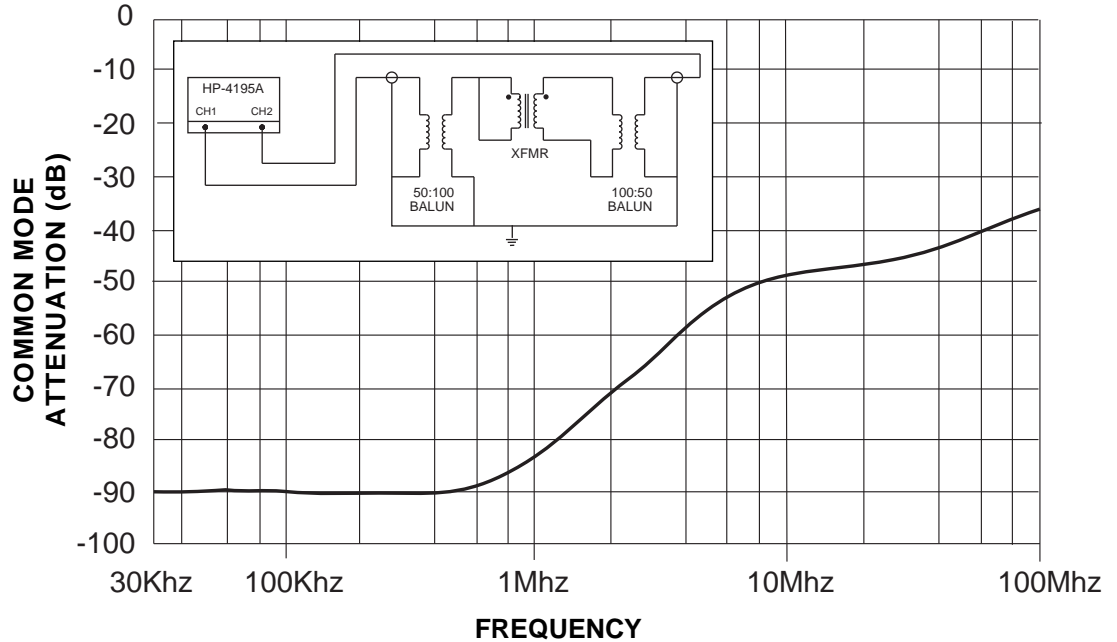

Figure 2 – Typical S-Interface Application Circuit for Motorola MC145574

*NOTE : Refer to Silicon Vendors' Application Notes for more details on power supply connection and specific component values.

Common Mode Choke Performance

Typical Common Mode Attenuation for the High Frequency Common Mode Choke (470 μ H) based on a 50 Ω system.



Typical Common Mode Attenuation for the Low Frequency Common Mode Choke (4.7 mH) based on a 50 Ω system.

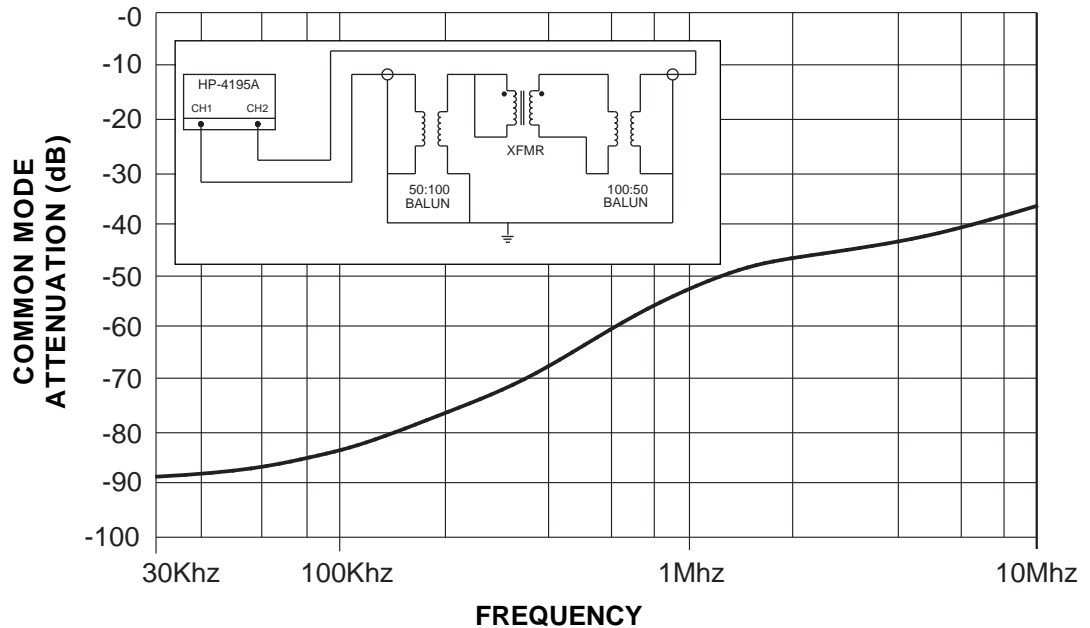

For More Information :

Corporate

12220 World Trade Drive
San Diego, CA 92128
Tel: 619 674 8100
FAX: 619 674 8262
<http://www.pulseeng.com>
Quick-Facts: 619 674 9672

Europe

1 & 2 Huxley Road
The Surrey Research Park
Guildford, Surrey GU2 5RE
United Kingdom
Tel: 44 1483 401700
FAX: 44 1483 401701

Asia

P.O. Box 26-11, KEPZ
6 Central Sixth Road
KEPZ, Kaohsiung
Taiwan, R.O.C.
Tel: 886 7 821 3141
FAX: 886 7 841 9707

Distributor

Performance warranty of products offered on this data sheet is limited to the parameters specified. Data is subject to change without notice. Other brand and product names mentioned herein may be products and/or registered trademarks of their respective owners.