

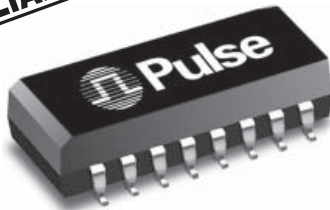



10/100 BASE-T SINGLE PORT TRANSFORMER MODULES

With 2:1 Transmit Turns Ratios Compatible with MicroLinear, MITEL, and SEEQ Transceivers



-  Patented Interlock Base design
-  Meets all IEEE 802.3 and ANSI X3.236 standards including 350 μ H OCL with 8 mA bias
-  Various pinout options available for optimal board layout
-  RoHS peak reflow temperature rating 245°C

Electrical Specifications @ 25°C — Operating Temperature 0°C to 70°C

Part Number	Insertion Loss (dB TYP)		Rise Time (ns TYP)		Return Loss (dB TYP)		Differential to Common Mode Rejection (dB TYP)		Crosstalk (dB TYP)		Isolation Voltage (Vrms MIN)
	0.1-60 MHz	60-100 MHz	0.1-60 MHz	60-100 MHz	0.1-60 MHz	60-100 MHz	0.1-60 MHz	60-100 MHz	0.1-60 MHz	60-100 MHz	
H1038NL	-1.0	3.5	-16	-12	-35	-32	-40	-35	1500		
H1094NL	-1.0	3.5	-16	-12	-35	-32	-40	-35	1500		

NOTE: For Tape & Reel packaging add a "T" suffix to the part number (i.e., H1038NLT).

U.S. Patent No. 5,015,981

Mechanical

H1038NL, H1094NL

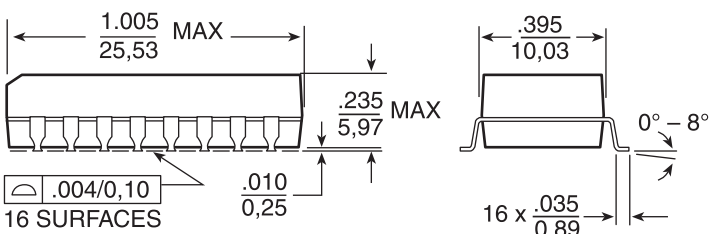
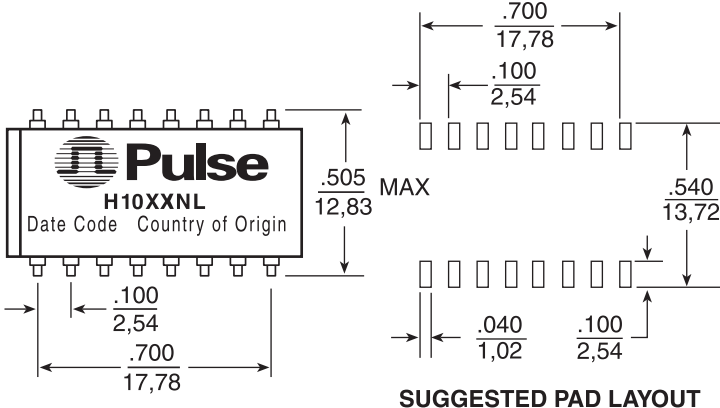

Dimensions: Inches
mm
Unless otherwise specified,
all tolerances are $\pm .010$
0,25

Weight 2.5 grams
Tube 23/tube
Tape & Reel 350/reel

Schematics

H1038NL

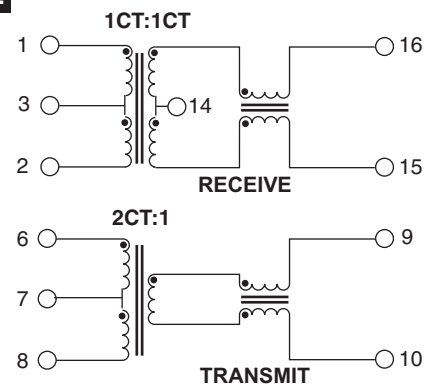

H1094NL

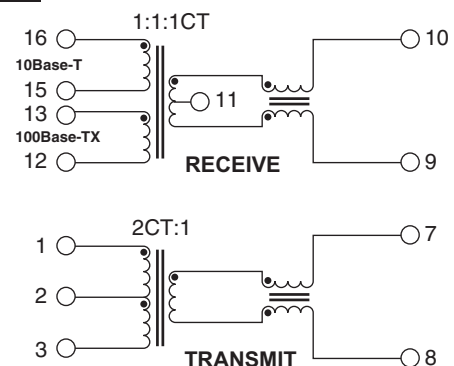

Downloaded from Elcodis.com electronic components distributor

10/100 BASE-T SINGLE PORT TRANSFORMER MODULES

With 2:1 Transmit Turns Ratios Compatible with MicroLinear, MITEL, and SEEQ Transceivers



Application Notes:

The magnetics modules have been specifically designed for implementation of 10/100 Mbps and 100Base-TX data links over data-grade unshielded twisted pair cable (UTP-5). The modules provide excellent EMI filtering and are targeted for adapter card and multiport applications. In designing these parts, Pulse has worked closely with members of the IEEE 802.3 and ANSI X3.236 committees to develop an analog interface that provides isolation and EMI filtering for MLT-3 and NRZ transceivers.

The H1094NL is designed to interface with the MicroLinear ML6692, ML6694, ML6697, or ML6698 in 10/100 Mbps applications. The H1038NL is optimized for SEEQ or MITEL (formerly GEC Plessey) 10/100 Mbps applications.

The transformers used in the modules provide high voltage isolation, wide bandwidth, and fast rise time. They utilize stable ferrite materials to minimize the degradation of primary inductance with base-line wander. At least 350 μ H of inductance will be provided by the transformers in these modules when 0–8 mA is applied across the windings over a temperature range of 0°–70°C. The High Speed LAN magnetics modules provide the designer with low-cost, analog components for simple and reliable designs. The parts are encased in IC-grade packaging, which shows superior performance under high temperature solder-reflow conditions.

For information on TP-FDDI, Fast Ethernet, and ATM solutions, contact the Pulse LAN Marketing Group.

For More Information:

Pulse Worldwide Headquarters	Pulse Europe	Pulse China Headquarters	Pulse North China	Pulse South Asia	Pulse North Asia
12220 World Trade Dr. San Diego, CA 92128 U.S.A.	Einsteinstrasse 1 D-71083 Herrenberg Germany	B402, Shenzhen Academy of Aerospace Technology Bldg. 10th Kejinan Rd. High-Tech Zone Nanshan District Shenzen, PR China 518057	Room 1503 XinYin Building No. 888 YiShan Rd. Shanghai 200233 China	135 Joo Seng Rd. #03-02 PM Industrial Bldg. Singapore 368363	No. 26, Kao Ching Rd. Yang Mei Chen Taoyuan Hsien Taiwan R. O. C.
www.pulseeng.com Tel: 858 674 8100 Fax: 858 674 8262	Tel: 49 7032 7806 0 Fax: 49 7032 7806 135	TEL: 86 755 33966678 FAX: 86 755 33966700	Tel: 86 21 54643211/2 Fax: 86 21 54643210	TEL: 65 6287 8998 FAX: 65 6280 0080	Tel: 886 3 4643715 Fax: 886 3 4641911

Performance warranty of products offered on this data sheet is limited to the parameters specified. Data is subject to change without notice. Other brand and product names mentioned herein may be trademarks or registered trademarks of their respective owners.

© Copyright, 2009. Pulse Engineering, Inc. All rights reserved.