

MGA-645T6

Low Noise Amplifier with Bypass/Shutdown Mode

Description

Avago Technologies' MGA-645T6 is an economical, easy-to-use GaAs MMIC Low Noise Amplifier (LNA) with Bypass/ Shutdown mode. The LNA features low noise and high linearity. The Bypass/Shutdown mode enables the LNA to be bypassed during high input signal power and reduce current consumption. It is housed in a low profile 2 x 1.3 x 0.4mm 6-pin Ultra Thin Package.

Related Product : DEMO-MGA-645T6 (demoboard for 2.3-2.7GHz applications)



Lifecycle status: **Active**



Features

- Low bias current
- High Linearity
- Low Noise Figure
- Ultra Thin Package
- Bypass/Shutdown Mode using a single pin

Applications

LNA for WiMax, WLAN, WiBro & DMB.

MGA-645T6

Low Noise Amplifier with Bypass/Shutdown Mode in Low Profile Package



Data Sheet

Description

Avago Technologies' MGA-645T6 is an economical, easy-to-use GaAs MMIC Low Noise Amplifier (LNA) with Bypass/ Shutdown mode. The LNA has low noise and high linearity achieved through the use of Avago Technologies' proprietary 0.5um GaAs Enhancement-mode pHEMT process. The Bypass/Shutdown mode enables the LNA to be bypassed during high input signal power and reduce current consumption. It is housed in a low profile 2 x 1.3 x 0.4mm 6-pin Ultra Thin Package. The compact footprint and low profile coupled with low noise, high linearity make the MGA-645T6 an ideal choice as a low noise amplifier for mobile receiver in the WiMax, WLAN(802.11b/g), WiBro and DMB applications.

Component Image



Note:
Package marking provides orientation and identification
"4F" = Product Code
"Y" = Year of manufacture
"M" = Month of manufacture

Pin Configuration

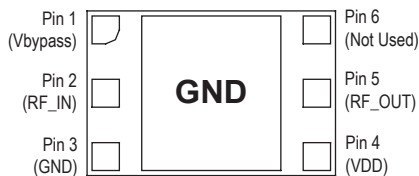

Top View

Simplified Schematic

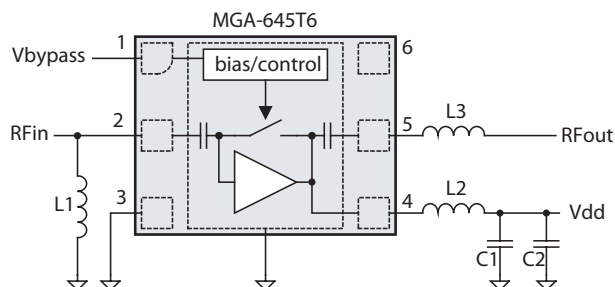

Features

- 2.0 x 1.3 x 0.4 mm³ 6-lead Ultra Thin Package
- Low bias current
- Simple matching network
- 1.5 GHz – 3 GHz operating range
- Adjustable bias current
- Low Noise Figure
- Bypass/Shutdown Mode using a single pin
- Low current consumption in Bypass Mode, <100uA
- Fully matched to 50 ohm in Bypass Mode
- High Linearity (LNA and Bypass Mode)
- Low profile package

Typical Performance

2.4 GHz; 3V, 7mA (typ):

- 15 dB Gain
- 1.1 dB Noise Figure with 9dB Input Return Loss
- +7 dBm Input IP3
- -5 dBm Input Power at 1dB gain compression
- 4.5 dB Insertion Loss in Bypass Mode
- 16dBm IIP3 in Bypass Mode (Pin = -20dBm)
- <100uA current consumption in Bypass & Shutdown Mode

Applications

- Low noise amplifier for GPS, WiMax, WLAN, WiBro and DMB applications.
- Other ultra low noise applications in the 1.5 – 3 GHz band



Attention: Observe precautions for handling electrostatic sensitive devices.

ESD Machine Model = 60 V
ESD Human Body Model = 200 V
Refer to Avago Application Note A004R:
Electrostatic Discharge, Damage and Control.

Absolute Maximum Rating ^[1] TA=25°C

Symbol	Parameter	Units	Absolute Max.
V _{dd}	Device Voltage	V	4
V _{bypass}	Control Voltage	V	(V _{dd} -0.3)
P _{in,max}	CW RF Input Power	dBm	+15
P _{diss}	Total Power Dissipation ^[3]	mW	80
T _j	Junction Temperature	°C	150
T _{STG}	Storage Temperature	°C	-65 to 150

Thermal Resistance ^[2,3]

(V_{dd} = 3.0V, I_d=7mA), θ_{jc} = 60 °C/W

Notes:

1. Operation of this device in excess of any of these limits may cause permanent damage.
2. Thermal resistance measured using Infra-Red Measurement Technique.
3. Board temperature T_B is 25 °C , for T_B >146 °C derate the device power at 14mW per °C rise in Board (package belly) temperature.

Product Consistency Distribution Charts ^[4]

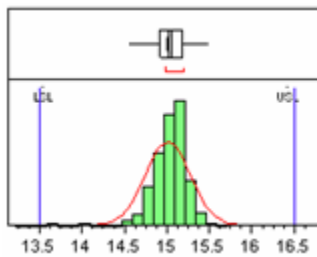

Figure 1. Gain @ 2.4 GHz , V_d 3V; V_{bypass} 1.8 V, LSL=13.5, Nominal=15.0, USL=16.5

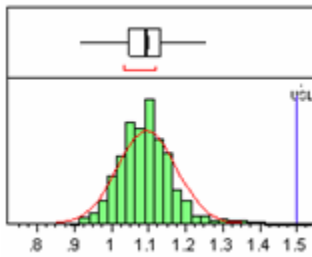

Figure 2. NF @ 2.4 GHz , V_d 3V; V_{bypass} 1.8 V, Nominal=1.1, USL=1.5

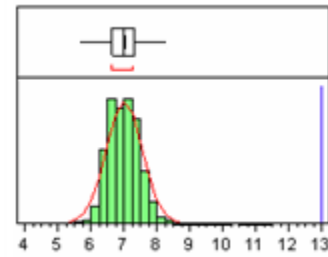

Figure 3. I_{ds} @ 2.4 GHz , V_d 3V; V_{bypass} 1.8 V, Nominal=7.0, USL=13.0

Notes:

4. Distribution data sample size are 500 samples taken from 3 different wafers and 3 different lots. Future wafers allocated to this product may have nominal values anywhere between the upper and lower limits.

Electrical Specifications ^[5,7]

T_A = 25 °C, V_{dd} = 3V, V_{bypass} = 1.8V, RF measurement at 2.4 GHz, measured on demo board (see Fig. 4) unless otherwise specified.

Symbol	Parameter and Test Condition	Units	Min.	Typ.	Max.
I _d	Bias Current	mA	-	7	13
Gain	Gain	dB	13.5	15	16.5
NF	Noise Figure (Typ.V _{bypass} =1.8V)	dB	-	1.1	1.5
IIP3 ^[6]	Input Third Order Intercept Point	dBm	-	+7	-
OP1dB	Output Power at 1dB Gain Compression	dBm	-	+9	-
S11	Input Return Loss, 50Ω source	dB	-	-9	-
S22	Output Return Loss, 50Ω load	dB	-	-15	-
S12	Reverse Isolation	dB	-	-27	-
S21 _{2BYPASS}	Bypass Mode Loss (V _{bypass} = 0)	dB	-	-4.5	-
IIP3 _{BYPASS}	Bypass Mode IIP3 (tested at -20dBm input Power)	dBm	-	16	-
I _d _{BYPASS}	Bypass Mode current	uA	-	80	-

Notes:

5. Measurements at 2.4GHz obtained using demo board described in Figure 1, with component values on Figure 2 (2.3 – 2.4 GHz)
6. 2.4GHz IIP₃ test condition: F_{RF1} = 2.395 GHz, F_{RF2} = 2.4 GHz with input power of -30dBm per tone.
7. Use proper bias, heatsink and derating to ensure maximum channel temperature is not exceeded. See absolute maximum ratings and application note for more details.

Package Dimensions

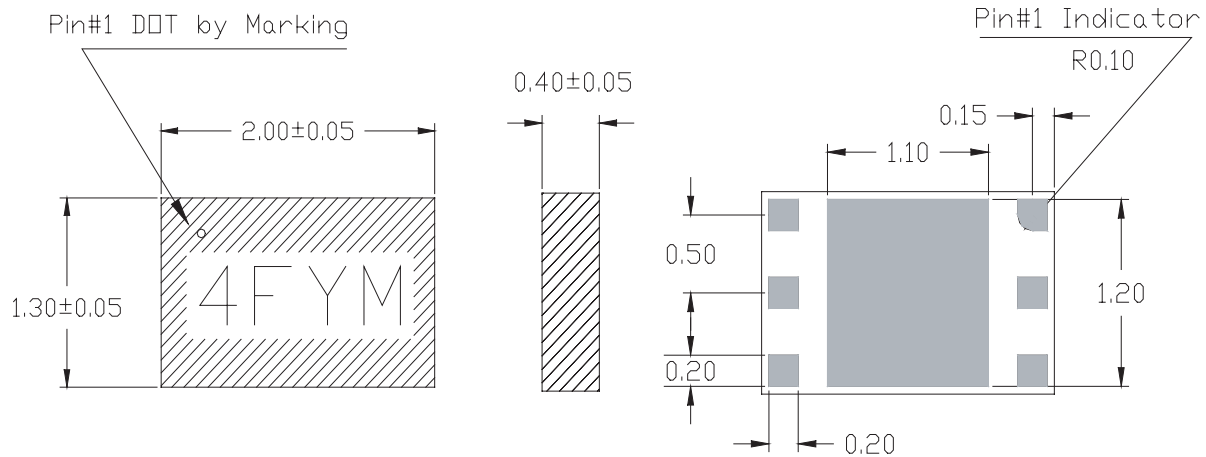

PCB Land Patterns and Stencil Design

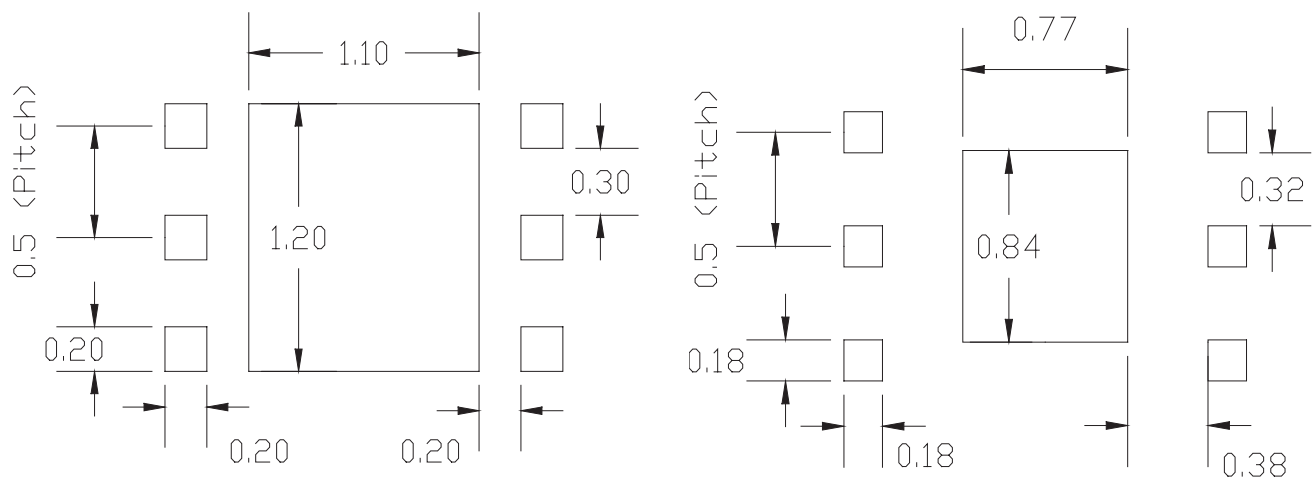

PCB Land Pattern (dimensions in mm)

Stencil Outline Drawing (dimensions in mm)

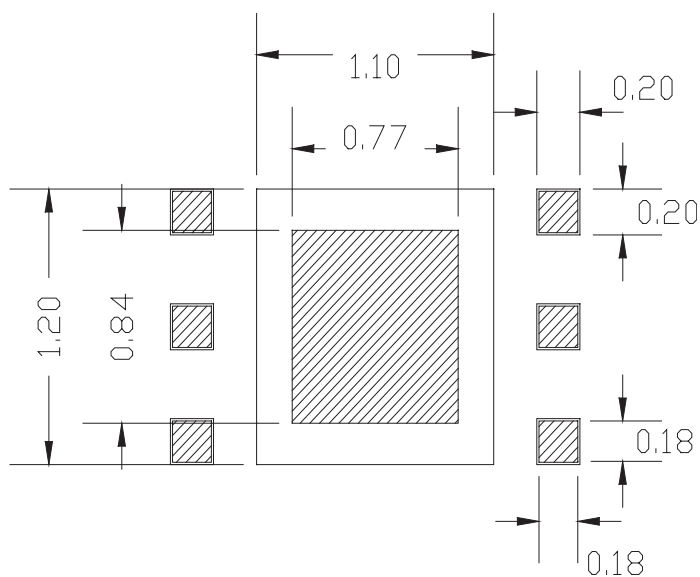

Combined PCB and Stencil Layouts (dimensions in mm)

Device Orientation

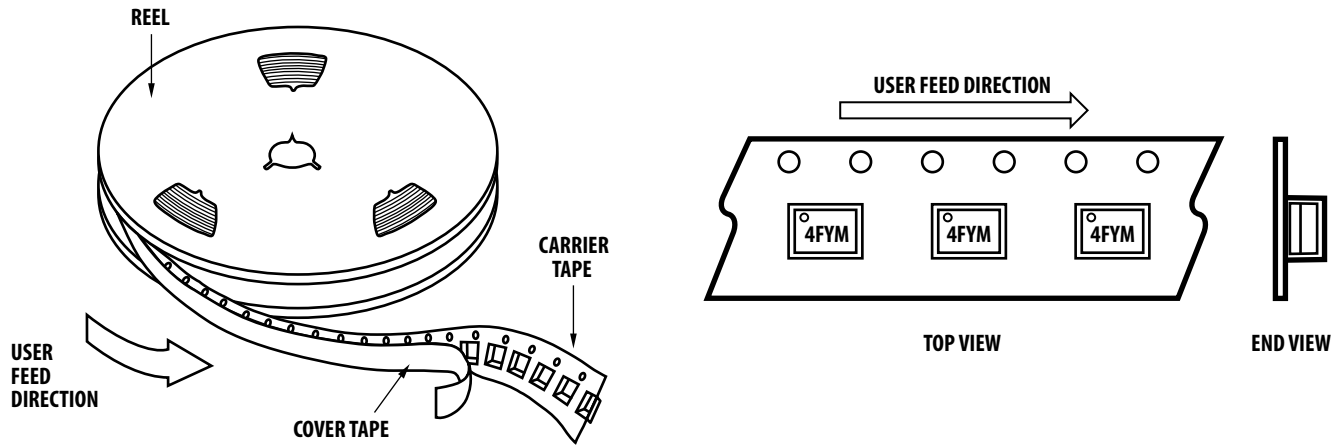

Tape Dimensions

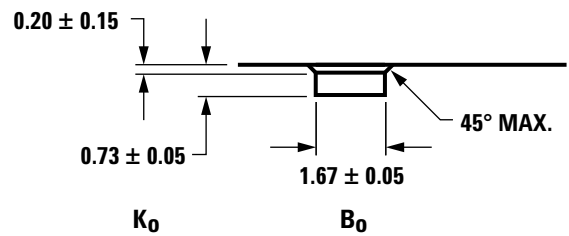
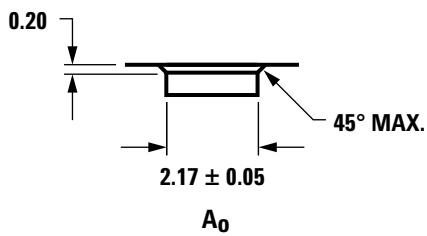
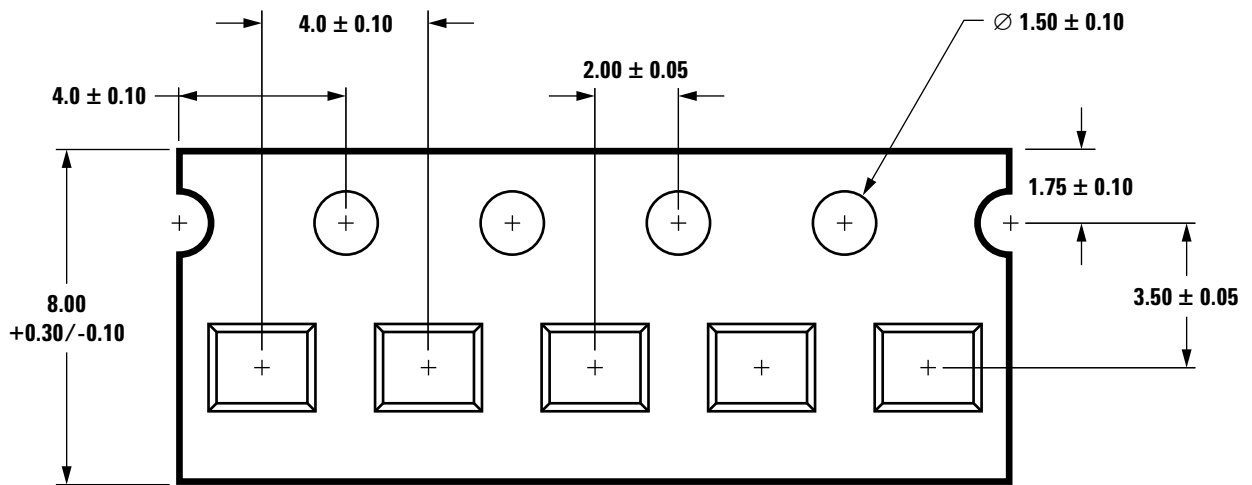

Part Number Ordering Information

Part #	Qty	Container
MGA-645T6-BLKG	100	Antistatic Bag
MGA-645T6-TR1G	3000	7" Reel
MGA-645T6-TR2G	10000	13" Reel