

FEATURES

- ❑ **Cost-effective, High-performance 32-bit DSP**
 - 300,000,000 MAC/S (multiply accumulates per second)
 - Dual MAC cycles per clock
 - 72-bit accumulators are the highest precision in the industry
 - 32K x 32-bit SRAM with three 2K blocks assignable to either Y data or program memory
- ❑ **Integrated DAC & ADC Functionality**
 - 8[†] Channels of DAC output: 108dB DR, -98dB THD+N
 - 4[†] Channels of ADC input: 105dB DR, -98dB THD+N
 - Integrated 5:1 analog mux feeds one stereo ADC
- ❑ **Configurable Serial Audio Inputs/Outputs**
 - Integrated 192 kHz S/PDIF Rx
 - Integrated 192 kHz S/PDIF Tx
 - Supports 32-bit Serial Data @ 192 kHz
 - Supports 32-bit audio sample I/O between DSP chips
 - TDM I/O modes
- ❑ **Supports Different Fs Sample Rates**
 - Three integrated hardware SRC blocks
 - Output can be master or slave
 - Supports dual-domain Fs on S/PDIF vs. I²S inputs
- ❑ **DSP Tool Set w/ Private Keys Protect Customer IP**
- ❑ **Integrated Clock Manager/PLL**
 - Flexibility to operate from internal PLL, external crystal, external oscillator
- ❑ **Input Fs Auto Detection w/ μ C Acknowledgement**
- ❑ **Host Control & Boot via I²C™ or SPI™ Serial Interface**
- ❑ **Configurable GPIOs and External Interrupt Input**
- ❑ **1.8V Core and a 3.3V I/O that is tolerant to 5V input**
- ❑ **Low-power Mode**

“[†]” Feature may differ on CS47024, CS47028, or CS47048. See [Table 2](#).

The CS470xx family is a new generation of audio system-on-a-chip (ASOC) processors targeted at high fidelity, cost sensitive designs. Derived from the highly successful CS48500 32-bit fixed point audio enhancement processor family, the CS470xx further simplifies system design and reduces total system cost by integrating the S/PDIF Rx, S/PDIF Tx, analog inputs, analog outputs, and SRCs. For example, a hardware SRC can down-sample a 192 kHz S/PDIF stream to a lower Fs to reduce memory and MIPS requirements for processing. This integration effectively reduces the chip count from 3 to 1 which allows smaller, less expensive board designs.

Target applications are:

- Automotive Head Units & Outboard Amplifiers
- Automotive Processors & Automotive Integration Hubs
- Digital TV
- MP3 Docking Stations
- AVR and DVD RX
- DSP Controlled Speakers (e.g. Subwoofers, Sound Bars)

The CS470xx is programmed using the simple yet powerful Cirrus proprietary DSP Composer™ GUI development and pre-production tuning tool. Processing chains may be designed using a drag-and-drop interface to place/utilize functional macro audio DSP primitives and custom audio filtering blocks. The end result is a software image that is downloaded to the DSP via serial control port.

The Cirrus Framework™ programming environment offers Assembly and C language compilers and other software development tools for porting existing code to the CS470xx family platform.

The CS470xx is available in a 100-pin LQFP package with exposed pad for better thermal characteristics. Both Commercial (0°C to +70°C) and Automotive (-40°C to +85°C) temperature grades.

Ordering Information:

See [page 33](#) for ordering information.

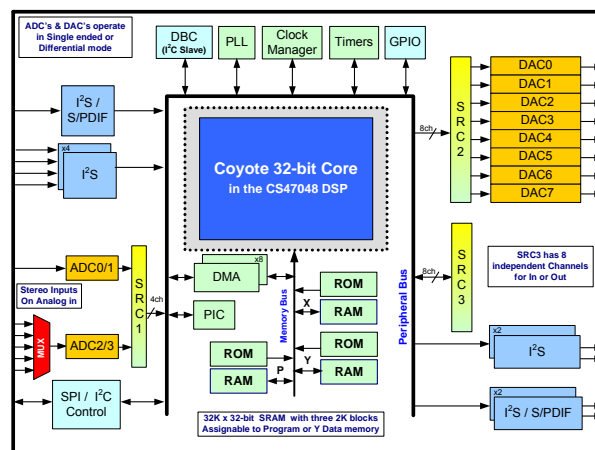

Contacting Cirrus Logic Support

For all product questions and inquiries contact a Cirrus Logic Sales Representative.
To find the one nearest to you go to www.cirrus.com.

IMPORTANT NOTICE

"Preliminary" product information describes products that are in production, but for which full characterization data is not yet available. Cirrus Logic, Inc. and its subsidiaries ("Cirrus") believe that the information contained in this document is accurate and reliable. However, the information is subject to change without notice and is provided "AS IS" without warranty of any kind (express or implied). Customers are advised to obtain the latest version of relevant information to verify, before placing orders, that information being relied on is current and complete. All products are sold subject to the terms and conditions of sale supplied at the time of order acknowledgment, including those pertaining to warranty, indemnification, and limitation of liability. No responsibility is assumed by Cirrus for the use of this information, including use of this information as the basis for manufacture or sale of any items, or for infringement of patents or other rights of third parties. This document is the property of Cirrus and by furnishing this information, Cirrus grants no license, express or implied under any patents, mask work rights, copyrights, trademarks, trade secrets or other intellectual property rights. Cirrus owns the copyrights associated with the information contained herein and gives consent for copies to be made of the information only for use within your organization with respect to Cirrus integrated circuits or other products of Cirrus. This consent does not extend to other copying such as copying for general distribution, advertising or promotional purposes, or for creating any work for resale.

CERTAIN APPLICATIONS USING SEMICONDUCTOR PRODUCTS MAY INVOLVE POTENTIAL RISKS OF DEATH, PERSONAL INJURY, OR SEVERE PROPERTY OR ENVIRONMENTAL DAMAGE ("CRITICAL APPLICATIONS"). CIRRUS PRODUCTS ARE NOT DESIGNED, AUTHORIZED OR WARRANTED FOR USE IN PRODUCTS SURGICALLY IMPLANTED INTO THE BODY, AUTOMOTIVE SAFETY OR SECURITY DEVICES, LIFE SUPPORT PRODUCTS OR OTHER CRITICAL APPLICATIONS. INCLUSION OF CIRRUS PRODUCTS IN SUCH APPLICATIONS IS UNDERSTOOD TO BE FULLY AT THE CUSTOMER'S RISK AND CIRRUS DISCLAIMS AND MAKES NO WARRANTY, EXPRESS, STATUTORY OR IMPLIED, INCLUDING THE IMPLIED WARRANTIES OF MERCHANTABILITY AND FITNESS FOR PARTICULAR PURPOSE, WITH REGARD TO ANY CIRRUS PRODUCT THAT IS USED IN SUCH A MANNER. IF THE CUSTOMER OR CUSTOMER'S CUSTOMER USES OR PERMITS THE USE OF CIRRUS PRODUCTS IN CRITICAL APPLICATIONS, CUSTOMER AGREES, BY SUCH USE, TO FULLY INDEMNIFY CIRRUS, ITS OFFICERS, DIRECTORS, EMPLOYEES, DISTRIBUTORS AND OTHER AGENTS FROM ANY AND ALL LIABILITY, INCLUDING ATTORNEYS' FEES AND COSTS, THAT MAY RESULT FROM OR ARISE IN CONNECTION WITH THESE USES.

Cirrus Logic, Cirrus, the Cirrus Logic logo designs, DSP Composer, and Cirrus Framework are trademarks of Cirrus Logic, Inc. All other brand and product names in this document may be trademarks or service marks of their respective owners.

SPI is a trademark of Motorola, Inc.

I²C is a trademark of Philips Semiconductor.

Dolby, Pro Logic, Dolby Headphone, Virtual Speaker and the double-D symbol are registered trademarks of Dolby Laboratories, Inc. Supply of an implementation of Dolby Technology does not convey a license nor imply a right under any patent, or any other industrial or Intellectual Property Right of Dolby Laboratories, to use the implementation in any finished end-user or ready-to-use final product. It is hereby notified that a license for such use is required from Dolby Laboratories.

SRS CircleSurround II technology is incorporated under license from SRS Labs, Inc. The SRS TruVolume technology/solution rights incorporated in the Cirrus Logic CS470xx products are owned by SRS Labs, a U.S. Corporation and licensed to Cirrus Logic, Inc. Purchaser of the Cirrus Logic CS470xx products must sign a license for use of the chip and display of the SRS Labs trademarks. Any products incorporating the Cirrus Logic CS470xx products must be sent to SRS Labs for review. SRS CircleSurround II is protected under US and foreign patents issued and/or pending. SRS TruVolume, SRS and (O) symbol are trademarks of SRS Labs, Inc. in the United States and selected foreign countries. Neither the purchase of the Cirrus Logic CS470xx products, nor the corresponding sale of audio enhancement equipment conveys the right to sell commercialized recordings made with any SRS technology/solution. SRS Labs requires all set makers to comply with all rules and regulations as outlined in the SRS Trademark Usage Manual.

Adobe Reader is a trademark of Adobe Systems, Inc.

Table of Contents

FEATURES	1
1. Documentation Strategy	6
2. Overview	6
2.1 Licensing	6
3. Code Overlays	7
4. Hardware Functional Description	10
4.1 Coyote 32-bit DSP Core	12
4.2 DSP Memory	12
4.2.1 DMA Controller	12
4.3 On-chip DSP Peripherals	13
4.3.1 Analog to Digital Converter Port (ADC)	13
4.3.2 Digital to Analog Converter Port (DAC)	13
4.3.3 Digital Audio Input Port (DAI)	13
4.3.4 S/PDIF RX Input Port (DAI)	13
4.3.5 Digital Audio Output Port (DAO)	13
4.3.6 S/PDIF TX Output Port (DAO)	13
4.3.7 Sample Rate Converters (SRC)	14
4.3.8 Serial Control Port (I ² C or SPI)	14
4.3.9 GPIO	14
4.3.10 PLL-based Clock Generator	14
4.3.11 Hardware Watchdog Timer	14
4.4 DSP I/O Description	15
4.4.1 Multiplexed Pins	15
4.4.2 Termination Requirements	15
4.4.3 Pads	15
4.5 Application Code Security	15
5. Characteristics and Specifications	16
5.1 Absolute Maximum Ratings	16
5.2 Recommended Operating Conditions	16
5.3 Digital DC Characteristics	16
5.4 Power Supply Characteristics	17
5.5 Thermal Data (100-Pin LQFP with Exposed Pad)	17
5.6 Digital Switching Characteristics— RESET	18
5.7 Digital Switching Characteristics— XTI	19
5.8 Digital Switching Characteristics—Internal Clock	19
5.9 Digital Switching Characteristics—Serial Control Port - SPI Slave Mode	20
5.10 Digital Switching Characteristics—Serial Control Port - SPI Master Mode	21
5.11 Digital Switching Characteristics—Serial Control Port - I ² C Slave Mode	22
5.12 Digital Switching Characteristics—Serial Control Port - I ² C Master Mode	23
5.13 Digital Switching Characteristics—Digital Audio Slave Input Port	24
5.14 Digital Switching Characteristics—Digital Audio Output Port	25
5.15 Digital Switching Characteristics—S/PDIF RX Port	26
5.16 ADC Characteristics	27
5.16.1 Analog Input Characteristics (Commercial)	27
5.16.2 Analog Input Characteristics (Automotive)	28
5.16.3 ADC Digital Filter Characteristics	30
5.17 DAC Characteristics	30
5.17.1 Analog Output Characteristics (Commercial)	30

5.17.2 Analog Output Characteristics (Automotive)	31
5.17.3 Combined DAC Interpolation & On-chip Analog Filter Response	32
6. Ordering Information	33
7. Environmental, Manufacturing, & Handling Information	33
8. Device Pinout Diagram	34
8.1 CS47048, 100-Pin LQFP Pinout Diagram	34
8.2 CS47028, 100-Pin LQFP Pinout Diagram	35
8.3 CS47024, 100-Pin LQFP Pinout Diagram	36
9. 100-pin LQFP with Exposed Pad Package Drawing	36
10. Parameter Definitions	38
10.1 Dynamic Range	38
10.2 Total Harmonic Distortion + Noise	38
10.3 Frequency Response	38
10.4 Interchannel Isolation	38
10.5 Interchannel Gain Mismatch	38
10.6 Gain Error	38
10.7 Gain Drift	38
11. Revision History	39

Figures

Figure 1. CS47048 Top-Level Block Diagram	10
Figure 2. CS47028 Top-Level Block Diagram	11
Figure 3. CS47024 Top-Level Block Diagram	11
Figure 4. RESET Timing at Power-On	18
Figure 5. RESET Timing after Power is Stable	18
Figure 6. XTI Timing	19
Figure 7. Serial Control Port - SPI Slave Mode Timing	20
Figure 8. Serial Control Port - SPI Master Mode Timing	21
Figure 9. Serial Control Port - I ² C Slave Mode Timing	22
Figure 10. Serial Control Port - I ² C Master Mode Timing	23
Figure 11. Digital Audio Input (DAI) Port Timing Diagram	24
Figure 12. Digital Audio Output Port Timing, Master Mode	25
Figure 13. Digital Audio Output Port Timing, Slave Mode	26
Figure 14. ADC Single-Ended Input Test Circuit	29
Figure 15. ADC Differential Input Test Circuit	29
Figure 16. DAC Single-Ended Output Test Circuit	31
Figure 17. DAC Differential Output Test Circuit	32
Figure 18. Maximum Loading	32
Figure 19. CS47048 Pinout Diagram	34
Figure 20. CS47028 Pinout Diagram	35
Figure 21. CS47024 Pinout Diagram	36
Figure 22. 100-Pin LQFP Package Drawing	37

Tables

Table 1. CS470xx Related Documentation	6
Table 2. CS470xx Device Selection Guide	8

Table 3. CS470xx Channel Count	9
Table 4. Memory Configurations for the CS470xx	12
Table 5. Ordering Information	33
Table 6. Environmental, Manufacturing, and Handling Information	33

1. Documentation Strategy

The *CS470xx Data Sheet* describes the CS47048, CS47028, and CS47024 audio processors. This document should be used in conjunction with the following documents when evaluating or designing a system around the CS470xx processors

Table 1. CS470xx Related Documentation

Document Name	Description
<i>CS470xx Data Sheet</i>	This document
<i>CS470xx Hardware User's Manual Guide</i>	Includes detailed system design information such as typical connection diagrams, boot-procedures, and pin descriptions
<i>AN333 - CS470xx Firmware User's Manual</i>	Includes a list of firmware modules available on the CS470xx family platform and detailed firmware design information including signal processing flow diagrams and control API information
<i>DSP Composer User's Manual</i>	Includes detailed configuration and usage information for the GUI development tool
<i>CDB470xx User's Manual</i>	Includes detailed instructions on the use of the CDB470xx development board

The scope of the *CS470xx Data Sheet* is primarily the hardware specifications of the CS470xx family of devices. This includes hardware functionality, characteristic data, pinout, and packaging information.

The intended audience for the *CS470xx Data Sheet* is the system PCB designer, MCU programmer, and the quality control engineer.

2. Overview

The CS470xx DSP is designed to provide high-performance post-processing and mixing of analog and digital audio. Dual clock domains are supported when the DAI and SPDIF RX inputs are used together. Integrated sample rate converters (SRCs) allow audio streams with different sample rates to be mixed. The low-power standby preserves battery life for applications which are always on, but not necessarily processing audio, such as automotive audio systems.

The CS470xx uses voltage-out DACs and is capable of supporting dual input clock domains through the use of the internal SRCs. The CS470xx is available in a 100-pin LQFP package. Refer to [Table 2](#) and [Table 3](#) for the input, output, and firmware configurations for the CS470xx DSP.

2.1 Licensing

Licenses are required for any third-party audio processing algorithms provided for the CS470xx. Please contact your local Cirrus Logic Sales representative for more information.

3. Code Overlays

The suite of software available for the CS470xx family consists of an operating system (OS) and a library of overlays. The software components for the CS470xx family include:

1. *OS/Kernel*—Encompasses all non-audio processing tasks, including loading data from external serial memory, processing host messages, calling audio-processing subroutines, error concealment, etc
2. *Decoder*—Any module that performs a compressed audio decode on IEC61937-packed data delivered via S/PDIF Rx or I²S input, such as Dolby Digital (AC3).
3. *Matrix-processor*—Any Module that performs a matrix decode on PCM data to produce more output channels than input channels (2→n channels). Examples are Dolby[®] Pro Logic[®] IIx and SRS Circle Surround II[®]. Generally speaking, these modules increase the number of valid channels in the audio I/O buffer.
4. *Virtualizer-processor*—Any module that encodes PCM data into fewer output channels than input channels (n→2 channels) with the effect of providing “phantom” speakers to represent the physical audio channels that were eliminated. Examples are Dolby Headphone[®] 2 and Dolby[®] Virtual Speaker[®] 2. Generally speaking, these modules reduce the number of valid channels in the audio I/O buffer.
5. *Post-processors*—Any module that processes audio I/O buffer PCM data. Examples are bass management, audio manager, tone control, EQ, delay, customer-specific effects, and any post-processing algorithms available for the CS470xx DSP.

The bulk of standard overlays are stored in ROM within the CS470xx, but a small image is required to configure the overlays and boot the DSP. This small image can either be stored in an external serial FLASH/EEPROM, or downloaded via a host controller through the SPI/I²C serial port.

The overlay structure reduces the time required to reconfigure the DSP when a processing change is requested. Each overlay can be reloaded independently without disturbing the other overlays. For example, when a different post-processor is selected, the OS, does not need to be reloaded — only the new post-processor.

[Table 2](#) lists the different configuration options available. Please refer to the *CS470xx Firmware User's Manual* for the latest listing of application codes and Cirrus Framework™ modules available. See [Table 3](#) which provides a summary of the available channels for each type of input and output communication mode for members of the CS470xx family of DSPs.

Table 2. CS470xx Device Selection Guide

Features	CS47048-CQZ CS47048-DQZ	CS47028-CQZ CS47028-DQZ	CS47024-CQZ CS47024-DQZ
Primary Applications	<ul style="list-style-type: none"> • 4-In/8-Out Car Audio • High-end Digital TV • Dual Source/Dual Zone 	<ul style="list-style-type: none"> • 2-In/8-Out Car Audio • Sound Bar • DVD Receiver 	<ul style="list-style-type: none"> • 2-In/4-Out Car Audio • Digital TV • Portable Audio Docking Station • Portable DVD • DVD Mini / Receiver • Multimedia PC Speakers
Package	100-pin LQFP with Exposed Pad		
DSP Core	Cirrus Logic 32-bit Core		
SRAM	32K x 32-bit SRAM with three 2K blocks x 32-bit SRAM, assignable to either Y data or program memory		
Integrated DAC and ADC	<ul style="list-style-type: none"> • 2 Channels of ADC input: with integrated 5:1 analog mux • 2 additional channels of ADC input: without mux • 8 channels of DAC output 	<ul style="list-style-type: none"> • 2 channels of ADC input: with integrated 5:1 analog mux • 8 channels of DAC output 	<ul style="list-style-type: none"> • 2 channels of ADC input: with integrated 5:1 analog mux • 4 channels of DAC output
Configurable Serial Audio Inputs/Outputs	<ul style="list-style-type: none"> • Integrated 192 kHz S/PDIF Rx, 2 Integrated 192 kHz S/PDIF Tx • I²S support for 32-bit Samples @ 192 kHz • TDM Input modes (Up to 8 channels) • TDM Output modes (Up to 8 channels) 		
Supports Different Fs Sample Rates	<ul style="list-style-type: none"> • Integrated hardware SRC blocks for all ADC and DAC channels • Additional 8-channel hardware SRC block • Dual-domain Fs on inputs (I²S and S/PDIF Rx) • Output can be master or slave 		
Other Features	<ul style="list-style-type: none"> • Integrated Clock Manager/PLL with flexibility to operate from internal PLL, external crystal, external oscillator • Host Control & Boot via SPI / I²C Serial Interface • DSP Tool Set w/ Private Keys Protect Customer IP • Configurable GPIOs and External Interrupts • Hardware Watchdog Timer 		

Table 3. CS470xx Channel Count

Product	PCM/TDM In ¹	TDM Out ¹	PCM Out	ADC with 5:1 Input Mux	ADC without Mux	DAC Out	S/PDIF In (Stereo Pairs)	S/PDIF Out (Stereo Pairs)
CS47048	<ul style="list-style-type: none"> • Up to 5 I²S lines, 2 channels per line or • 1 TDM line, up to 8 channels per line. 	Up to 8 channels	8	2	2	8	1	2
CS47028	<ul style="list-style-type: none"> • Up to 5 I²S lines, 2 channels per line or • 1 TDM line, up to 8 channels per line. 	Up to 8 channels	8	2	0	8	1	2
CS47024	<ul style="list-style-type: none"> • Up to 5 I²S lines, 2 channels per line or • 1 TDM line, up to 8 channels per line. 	Up to 8 channels	8	2	0	4	1	2

1. Please contact your Cirrus Logic representative to determine the TDM modes that are supported. The CS470xx can support up to 8 channels per line, but the DSP software provided for the IC may restrict this capability.

4. Hardware Functional Description

The CS470xx family, which includes the CS47048, CS47028, and CS47024 DSPs, is a true system-on-a-chip that combines a powerful 32-bit DSP engine with analog/digital audio inputs and analog/digital audio outputs. It can be integrated into a complex multi-DSP processing system, or stand alone in an audio product that requires analog-in and analog-out. A top level block diagram for the CS47048, CS47028, and CS47024 products are shown in Figure 1, Figure 2, and Figure 3 respectively.

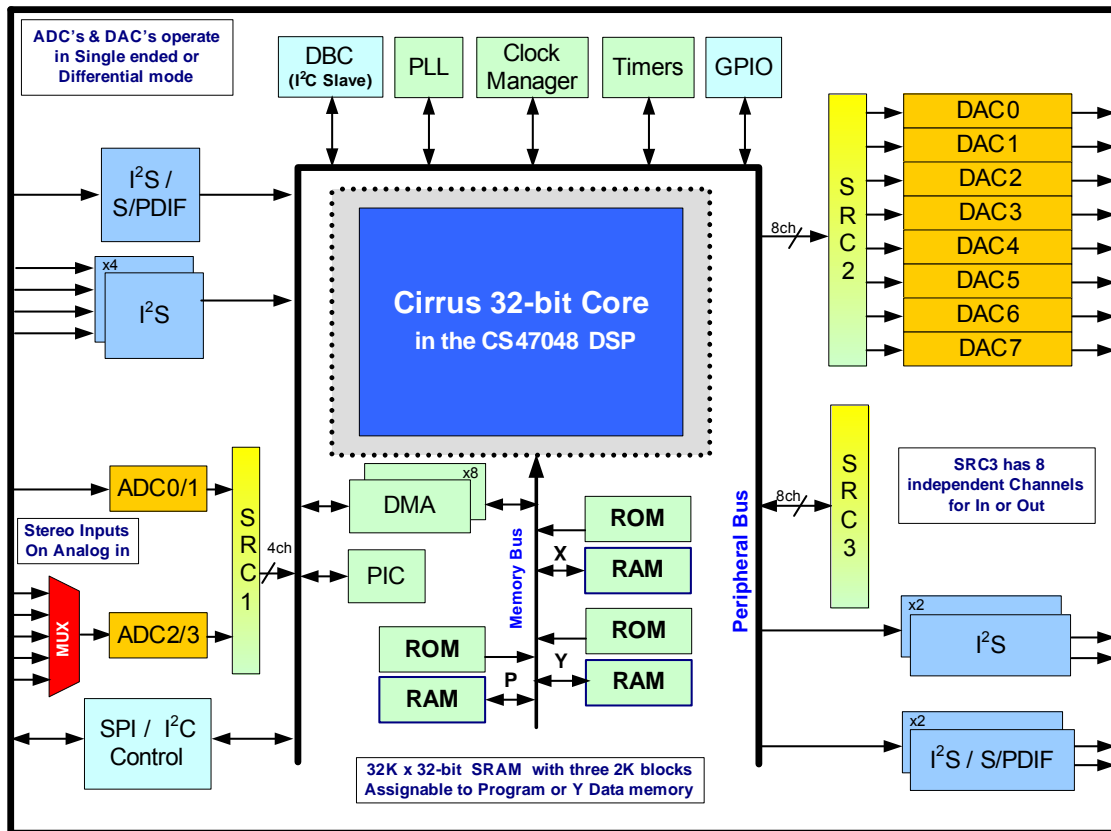

Figure 1. CS47048 Top-Level Block Diagram

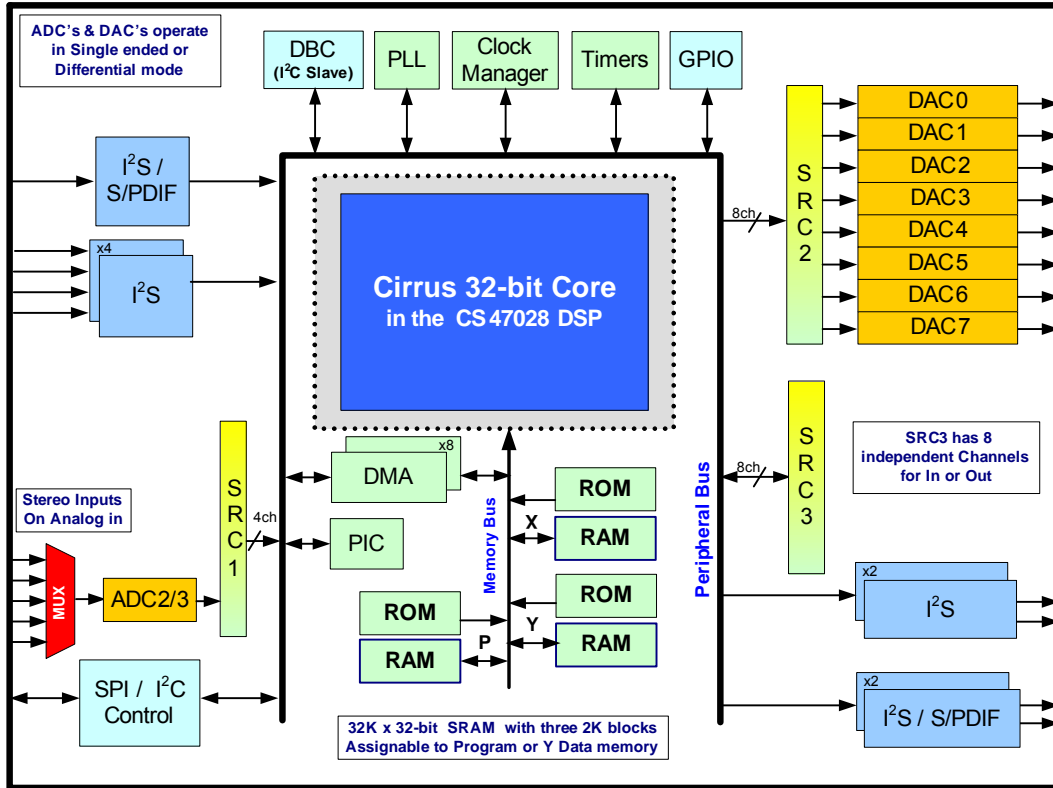

Figure 2. CS47028 Top-Level Block Diagram

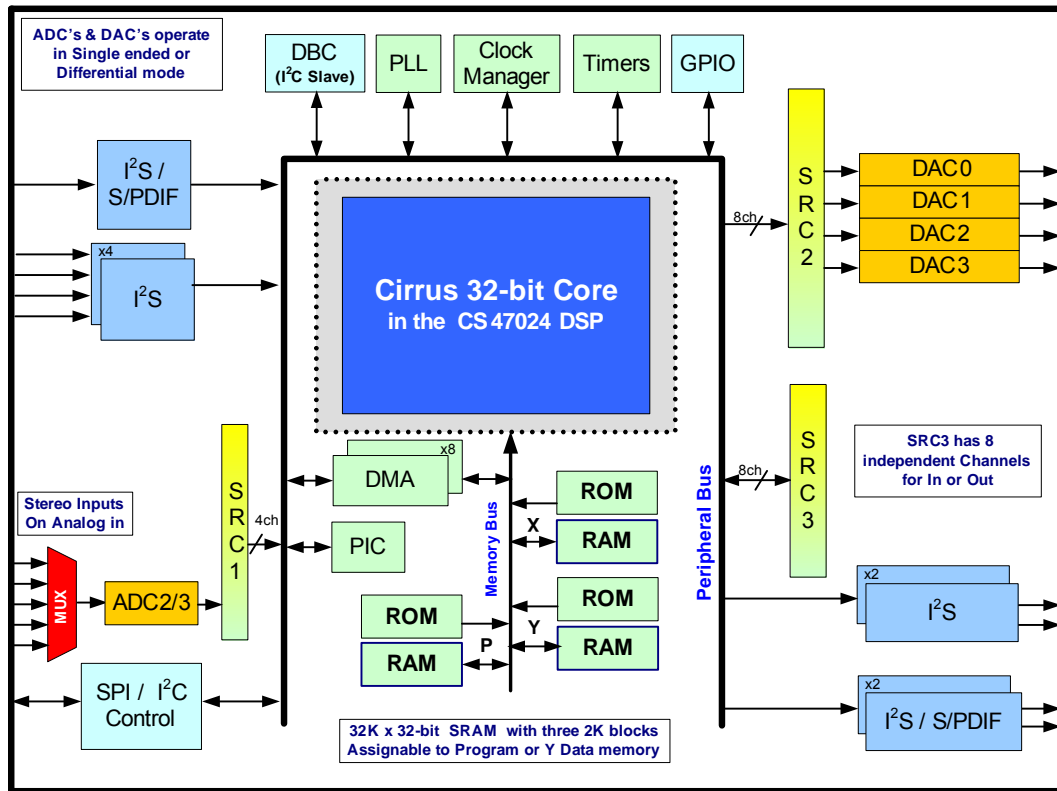

Figure 3. CS47024 Top-Level Block Diagram

4.1 Cirrus Logic 32-bit DSP Core

The CS470xx comes with a Cirrus Logic 32-bit core with separate X and Y data and P code memory spaces. The DSP core is a high-performance, 32-bit, user-programmable, fixed-point DSP that is capable of performing two multiply-and-accumulate (MAC) operations per clock cycle. The DSP core has eight 72-bit accumulators, four X-data and four Y-data registers, and 12 index registers.

The DSP core is coupled to a flexible 8-channel DMA engine. The DMA engine can move data between peripherals such as the serial control port (SCP), digital audio input (DAI) and digital audio output (DAO), sample rate converters (SRC), analog-to-digital converters (ADC), digital-to-analog converters (DAC), or any DSP core memory, all without the intervention of the DSP. The DMA engine off-loads data move instructions from the DSP core, leaving more MIPS available for signal processing instructions.

CS470xx functionality is controlled by application codes that are stored in on-chip ROM or downloaded to the CS470xx from a host controller or external serial FLASH/EEPROM.

Users can develop their applications using DSP Composer™ to create the processing chain and then compile the image into a series of commands that are sent to the CS470xx through the SCP. The processing application can either load modules (post-processors) from the DSP's on-chip ROM, or custom firmware can be downloaded through the SCP.

The CS470xx is suitable for a variety of audio post-processing applications where sound quality via sound enhancement and speaker/cabinet tuning is required to achieve the sound quality consumers expect. Examples of such applications include automotive head-ends, automotive amplifiers, docking stations, sound bars, subwoofers, and boom boxes.

4.2 DSP Memory

The DSP core has its own on-chip data and program RAM and ROM and does not require external memory for post-processing applications.

The Y-RAM and P-RAM share a single block of memory that includes three 2K word blocks (32 bits/word) that are assignable to either Y-RAM or P-RAM as shown in [Table 4](#).

Table 4. Memory Configurations for the CS470xx

P-RAM	X-RAM	Y-RAM
14K words	10K words	8K words
12K words	10K words	10K words
10K words	10K words	12K words
8K words	10K words	14K words

4.2.1 DMA Controller

The powerful 8-channel DMA controller can move data between 8 on-chip resources. Each resource has its own arbiter: X, Y, and P RAMs/ROMs and the peripheral bus. Modulo and linear addressing modes are supported, with flexible start address and increment controls. The service intervals for each DMA channel, as well as up to 6 interrupt events, are programmable.

4.3 On-chip DSP Peripherals

4.3.1 Analog to Digital Converter Port (ADC)

The ADCs in the CS470xx devices feature dynamic range performance in excess of 100 dB. Please see [Section 5.16 “ADC Characteristics” on page 27](#) for more details on CS470xx ADC performance. The CS47024 and CS47028 devices support up to 2 simultaneous channels of analog-to-digital conversion with the input source selectable using an integrated 5:1 stereo analog mux (analog inputs AIN_2A/B through AIN_6A/B). The CS47048 device adds a second pair of ADCs that are directly connected to input pins AIN_1A/B providing a total of 4 simultaneous channels of analog-to-digital conversion. This feature gives the CS47048 the ability to select from a total of six stereo pairs of analog input. A single programmable bit selects single-ended or differential mode signals for all inputs. The conversions are performed with either $F_s=96$ kHz or $F_s=192$ kHz.

4.3.2 Digital to Analog Converter Port (DAC)

The DACs in the CS470xx devices feature dynamic range performance in excess of 100 dB. Please see [Section 5.17 “DAC Characteristics” on page 30](#) for more details on CS470xx DAC performance. The CS47024 device supports four simultaneous channels of digital-to-analog conversion. The CS47028 and CS47048 devices provide eight simultaneous channels of digital-to-analog conversion. The DACs have voltage mode outputs that can be connected either as single-ended or differential signals. The conversions are performed with $F_s=96$ kHz.

4.3.3 Digital Audio Input Port (DAI)

The input capabilities for each version of the CS470xx are summarized in [Table 2](#) and [Table 3](#).

Up to five DAI ports are available. Two of the DAI ports can be programmed to implement other functions. If the SPI mode is used, the DAI_DATA4 pin becomes the SCP_CS input. The integrated S/PDIF receiver can be used to take over the DAI_DATA3 pin.

The DAI port PCM inputs have a single slave-only clock domain. The S/PDIF receiver, if used, is a separate clock domain. The output of the S/PDIF Rx can then be converted through one of the internal SRC blocks to synchronize with the PCM input. The sample rate of the input clock domains can be determined automatically by the DSP, off-loading the task of monitoring the S/PDIF Rx from the host. A time-stamping feature provides the ability to also sample-rate convert the input data via software. The DAI port supports PCM format with word lengths up to 32 bits and sample rates as high as 192 kHz.

The DAI also supports a time division multiplexed (TDM) mode that packs up to 10 PCM audio channels on a single data line.

4.3.4 S/PDIF RX Input Port (DAI)

One of the PCM pins of the DAI can also be used as a DC-coupled, TTL-level S/PDIF Rx input capable of receiving and demodulating bi-phase encoded S/PDIF signals with $F_s \leq 192$ kHz.

4.3.5 Digital Audio Output Port (DAO)

DAO port supports PCM resolutions of up to 32-bits. The port supports sample rates (F_s) as high as 192 kHz. The port can be configured as an independent clock domain mastered by the DSP, or as a clock slave if an external MCLK or SCLK/LRCLK source is available.

The DAO also supports a time division multiplexed (TDM) mode, that packs up to 8 channels of PCM audio on a single data line.

4.3.6 S/PDIF TX Output Port (DAO)

Two of the serial audio pins can be re-configured as S/PDIF TX pins that drive a bi-phase encoded S/PDIF signal (data with embedded clock on a single line).

4.3.7 Sample Rate Converters (SRC)

All CS470xx devices have at least two internal hardware SRC modules. One is directly associated with the ADCs and normally serves to convert data from the 96/192 kHz sampling rate of the ADCs to another F_s appropriate for mixing with other audio in the system. If the ADCs are not being used, this SRC can convert up to 4 channels of audio data from one input sample rate (F_{si}) to another output sample rate (F_{so}).

The other SRC module is directly associated with the DACs and normally serves to convert data from the DSP into the 96 kHz sample rate needed by the DACs. If the DACs are not being used, this SRC can convert up to 8 channels of audio data from the one input sample rate (F_{si}) to another output sample rate (F_{so}).

The CS47028 and CS47048 devices have an additional stand-alone 8-channel SRC module. This SRC module can be used to make independent input clock domains synchronous (different F_s on PCM input and S/PDIF Rx). The CS47024 has an additional 2-channel SRC module. The CS47024 has the 8-channel SRC block.

4.3.8 Serial Control Port (I²C or SPI)

The on-chip serial control port is capable of operating as master or slave in either SPI or I²C modes. Master/Slave operation is chosen by mode select pins when the CS470xx comes out of reset. The serial clock pin can support frequencies as high as 25 MHz in SPI mode (SPI clock speed must always be \leq (DSP Core Frequency/2)). The CS470xx serial control port also includes a pin for flow control of the communications interface (SCP_BSY) and a pin to indicate when the DSP has a message for the host (SCP_IRQ).

4.3.9 GPIO

Many of the CS470xx peripheral pins are multiplexed with GPIO. Each GPIO can be configured as an output, an input, or an input with interrupt. Each input-pin interrupt can be configured as rising edge, falling edge, active-low, or active-high.

4.3.10 PLL-based Clock Generator

The low-jitter PLL generates integer or fractional multiples of a reference frequency which are used to clock the DSP core and peripherals. Through a second PLL divider chain, a dependent clock domain can be output on the DAO port for driving audio converters. The CS470xx defaults to running from the external reference frequency and is switched to use the PLL output after overlays have been loaded and configured, either through master boot from an external FLASH or through host control. A built-in crystal oscillator circuit with a buffered output is provided. The buffered output frequency ratio is selectable between 1:1 (default) or 2:1.

4.3.11 Hardware Watchdog Timer

The CS470xx has an integrated watchdog timer that acts as a “health” monitor for the DSP. The watchdog timer must be reset by the DSP before the counter expires, or the entire chip is reset. This peripheral ensures that the CS470xx will reset itself in the event of a temporary system failure. In stand-alone mode (i.e. no host MCU), the DSP will reboot from external FLASH. In slave mode (i.e. host MCU present) a GPIO will be used to signal the host that the watchdog has expired and the DSP should be rebooted and re-configured.

4.4 DSP I/O Description

4.4.1 Multiplexed Pins

Many of the CS470xx pins are multi-functional. For details on pin functionality please refer to the *CS470xx Hardware User's Manual*.

4.4.2 Termination Requirements

Open-drain pins on the CS470xx must be pulled high for proper operation. Please refer to the *CS470xx Hardware User's Manual* to identify which pins are open-drain and what value of pull-up resistor is required for proper operation.

Mode select pins on CS470xx are used to select the boot mode upon the rising edge from reset. A detailed explanation of termination requirements for each communication mode select pin can be found in the *CS470xx Hardware User's Manual*.

4.4.3 Pads

The CS470xx Digital I/Os operate from the 3.3 V supply and are 5 V tolerant.

4.5 Application Code Security

The external program code may be encrypted by the programmer to protect any intellectual property it may contain. A secret, customer-specific key is used to encrypt the program code that is to be stored external to the device. Please contact your local Cirrus representative for details.

5. Characteristics and Specifications

Note: All data sheet minimum and maximum timing parameters are guaranteed over the rated voltage and temperature. All data sheet typical parameters are measured under the following conditions: $T = 25\text{ }^{\circ}\text{C}$, $V_{DD} = 1.8\text{ V}$, $V_{DDIO} = V_{DDA} = 3.3\text{ V}$, $GND = GNDIO = GNDA = 0\text{ V}$.

5.1 Absolute Maximum Ratings

($GND = GNDIO = GNDA = 0\text{ V}$; all voltages with respect to 0 V)

Parameter	Symbol	Min	Max	Unit	
DC power supplies:	Core supply	VDD	-0.3	2.0	V
	Analog supply	VDDA	-0.3	3.6	V
	I/O supply	VDDIO	-0.3	3.6	V
	VDDA – VDDIO		-	0.3	V
Input pin current, any pin except supplies	I_{in}	-	+/- 10	mA	
Input voltage on PLL_REF_RES	V_{filt}	-0.3	3.6	V	
Input voltage on digital I/O pins	V_{inio}	-0.3	5.0	V	
Analog Input Voltage	V_{in}	AGND - 0.7	VA + 0.7	V	
Storage temperature	T_{stg}	-65	150	$^{\circ}\text{C}$	

Caution: Operation at or beyond these limits may result in permanent damage to the device. Normal operation is not guaranteed at these extremes.

5.2 Recommended Operating Conditions

($GND = GNDIO = GNDA = 0\text{ V}$; all voltages with respect to 0 V)

Parameter	Symbol	Min	Typ	Max	Unit	
DC power supplies:	Core supply	VDD	1.71	1.8	1.89	V
	Analog supply	VDDA	3.13	3.3	3.46	V
	I/O supply	VDDIO	3.13	3.3	3.46	V
	VDDA – VDDIO			0		V
Ambient operating temperature	T_A	Commercial - CQZ	0	-	+ 70	$^{\circ}\text{C}$
		Automotive - DQZ	- 40		+ 85	

Note: It is recommended that the 3.3 V IO supply come up ahead of or simultaneously with the 1.8 V core supply.

5.3 Digital DC Characteristics

(Measurements performed under static conditions.)

Parameter	Symbol	Min	Typ	Max	Unit
High-level input voltage	V_{IH}	2.0	-	-	V
Low-level input voltage, except XTI	V_{IL}	-	-	0.8	V
Low-level input voltage, XTI	V_{ILXTI}	-	-	0.6	V
Input Hysteresis	V_{hys}		0.4		V
High-level output voltage ($I_O = -2\text{ mA}$), except XTO	V_{OH}	VDDIO * 0.9	-	-	V
Low-level output voltage ($I_O = 2\text{ mA}$), except XTO	V_{OL}	-	-	VDDIO * 0.1	V
Input leakage XTI	I_{LXTI}	-	-	5	μA
Input leakage current (all digital pins with internal pull-up resistors enabled)	I_{LEAK}	-	-	70	μA

5.4 Power Supply Characteristics

Note: Measurements performed under operating conditions)

Parameter	Min	Typ	Max	Unit
Operational Power Supply Current:				
VDD: Core and I/O operating ¹	-	325	-	mA
VDDA: PLL operating current	-	16	-	mA
VDDA: DAC operating current (all 8 channels enabled)	-	56	-	mA
VDDA: ADC operating current (all 4 channels enabled)	-	34	-	mA
VDDIO: With most ports operating	-	27	-	mA
Total Operational Power Dissipation:		1025		mW
Standby Power Supply Current:				
VDD: Core and I/O not clocked	-	410	-	μA
VDDA: PLLs halted	-	26	-	μA
VDDA: DAC disabled	-	40	-	μA
VDDA: ADC disabled	-	24	-	μA
VDDIO: All connected I/O pins 3-stated by other ICs in system	-	215	-	μA
Total Standby Power Dissipation:		1745		μW

1. Dependent on application firmware and DSP clock speed.

5.5 Thermal Data (100-Pin LQFP with Exposed Pad)

Parameter	Symbol	Min	Typ	Max	Unit
Thermal Resistance (Junction to Ambient)	θ_{ja}				°C / Watt
Two-layer Board ¹		-	34	-	
Four-layer Board ²		-	18	-	
Thermal Resistance (Junction to Top of Package)	ψ_{jt}				°C / Watt
Two-layer Board ¹		-	0.54	-	
Four-layer Board ²		-	.28	-	

1. To calculate the die temperature for a given power dissipation:

$$T_j = \text{Ambient temperature} + [(\text{Power Dissipation in Watts}) * \theta_{ja}]$$

2. To calculate the case temperature for a given power dissipation:

$$T_c = T_j - [(\text{Power Dissipation in Watts}) * \psi_{jt}]$$

Note: Two-layer board is specified as a 76 mm X 114 mm, 1.6 mm thick FR-4 material with 1-oz. copper covering 20% of the top & bottom layers.

Note: Four-layer board is specified as a 76 mm X 114 mm, 1.6 mm thick FR-4 material with 1-oz. copper covering 20% of the top & bottom layers and 0.5-oz. copper covering 90% of the internal power plane & ground plane layers.

5.6 Digital Switching Characteristics— $\overline{\text{RESET}}$

Parameter	Symbol	Min	Max	Unit
$\overline{\text{RESET}}$ minimum pulse width low ¹	T_{rstl}	1	-	μs
All bidirectional pins high-Z after $\overline{\text{RESET}}$ low	T_{rst2z}	-	200	ns
Configuration pins setup before $\overline{\text{RESET}}$ high	T_{rstsu}	50	-	ns
Configuration pins hold after $\overline{\text{RESET}}$ high	T_{rsthld}	20	-	ns

1. The rising edge of $\overline{\text{RESET}}$ must not occur before the power supplies are stable at their recommended operating values as described in Section 5.2. In addition, for the configuration pins to be read correctly, the $\overline{\text{RESET}}$ T_{rstl} requirement must be met.

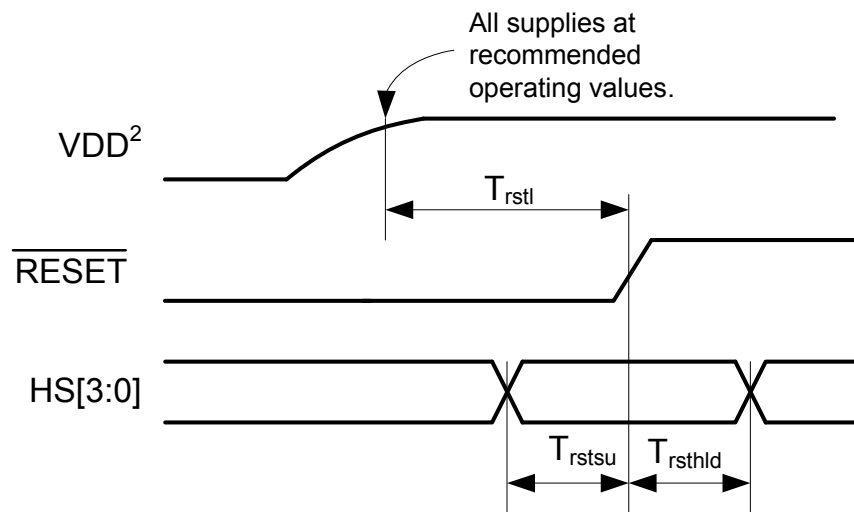

² Refers to all power supplies.

Figure 4. $\overline{\text{RESET}}$ Timing at Power-On

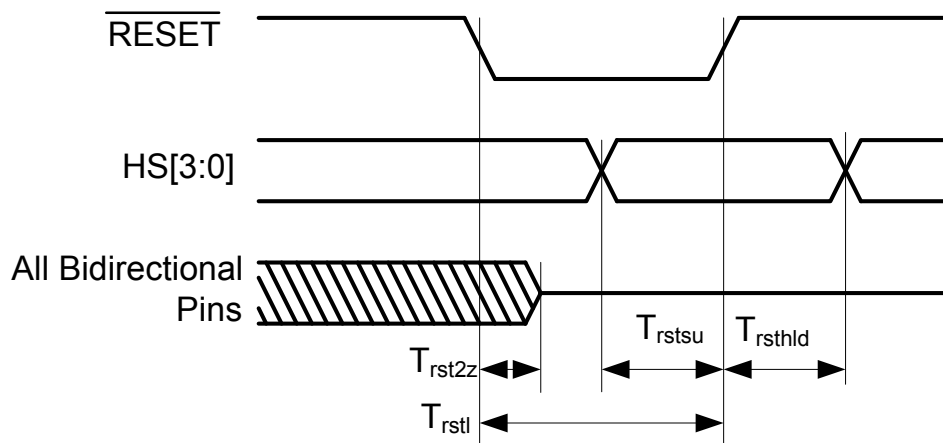

Figure 5. $\overline{\text{RESET}}$ Timing after Power is Stable

5.7 Digital Switching Characteristics — XTI

Parameter	Symbol	Min	Max	Unit
External Crystal operating frequency ¹	F_{xtal}	12.288	24.576	MHz
XTI period	T_{clki}	41	81	ns
XTI high time	T_{clkih}	13.3	-	ns
XTI low time	T_{clkil}	13.3	-	ns
External Crystal Load Capacitance (parallel resonant) ²	C_L	10	18	pF
External Crystal Equivalent Series Resistance	ESR		50	Ω

- Part characterized with the following crystal frequency values: 12.288 and 24.576 MHz
- C_L refers to the total load capacitance as specified by the crystal manufacturer. Crystals which require a C_L outside this range should be avoided. The crystal oscillator circuit design should follow the crystal manufacturer's recommendation for load capacitor selection.

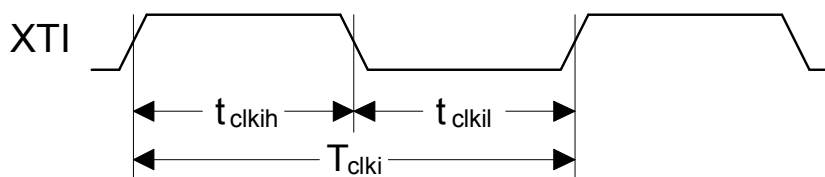

Figure 6. XTI Timing

5.8 Digital Switching Characteristics — Internal Clock

Parameter	Symbol	Min		Max		Unit
		2- Layer Boards	4-Layer Boards	2- Layer Boards	4-Layer Boards	
Internal DSP_CLK frequency ¹	F_{dclk}	(See Note 2)	(See Note 2)			MHz
CS47048-CQZ		F_{xtal}	F_{xtal}	147	147	
CS47048-DQZ		F_{xtal}	F_{xtal}	131	147	
CS47028-CQZ		F_{xtal}	F_{xtal}	147	147	
CS47028-DQZ		F_{xtal}	F_{xtal}	131	147	
CS47024-CQZ		F_{xtal}	F_{xtal}	147	147	
CS47024-DQZ		F_{xtal}	F_{xtal}	131	147	
Internal DSP_CLK period ¹	DCLKP					ns
CS47048-CQZ		6.8	6.8	$1/F_{xtal}$	$1/F_{xtal}$	
CS47048-DQZ		7.6	6.8	$1/F_{xtal}$	$1/F_{xtal}$	
CS47028-CQZ		6.8	6.8	$1/F_{xtal}$	$1/F_{xtal}$	
CS47028-DQZ		7.6	6.8	$1/F_{xtal}$	$1/F_{xtal}$	
CS47024-CQZ		6.8	6.8	$1/F_{xtal}$	$1/F_{xtal}$	
CS47024-DQZ		7.6	6.8	$1/F_{xtal}$	$1/F_{xtal}$	

- After initial power-on reset, $F_{dclk} = F_{xtal}$. After initial kickstart commands, the PLL is locked to max F_{dclk} and remains locked until the next power-on reset.
- See [Section 5.7](#) for all references to F_{xtal} .

5.9 Digital Switching Characteristics — Serial Control Port - SPI Slave Mode

Parameter	Symbol	Min	Typical	Max	Units
SCP_CLK frequency ¹	f_{spisck}	-		25	MHz
$\overline{\text{SCP_CS}}$ falling to SCP_CLK rising	t_{spicss}	24		-	ns
SCP_CLK low time	t_{spickl}	20		-	ns
SCP_CLK high time	t_{spickh}	20		-	ns
Setup time SCP_MOSI input	t_{spidsu}	5		-	ns
Hold time SCP_MOSI input	t_{spidh}	5		-	ns
SCP_CLK low to SCP_MISO output valid	t_{spidov}	-		11	ns
SCP_CLK falling to $\overline{\text{SCP_IRQ}}$ rising	$t_{spiirqh}$	-		27	ns
$\overline{\text{SCP_CS}}$ rising to $\overline{\text{SCP_IRQ}}$ falling	$t_{spiirql}$	0			ns
SCP_CLK low to $\overline{\text{SCP_CS}}$ rising	t_{spicsh}	24		-	ns
$\overline{\text{SCP_CS}}$ rising to SCP_MISO output high-Z	$t_{spicsdz}$	-	20		ns
SCP_CLK rising to $\overline{\text{SCP_BSY}}$ falling	$t_{spibsyl}$	-	$3 \cdot \text{DCLKP} + 20$		ns

1. f_{spisck} indicates the maximum speed of the hardware. The system designer should be aware that the actual maximum speed of the communication port may be limited by the firmware application. Flow control using the $\overline{\text{SCP_BSY}}$ pin should be implemented to prevent overflow of the input data buffer. At boot the maximum speed is $F_{xtal}/3$.

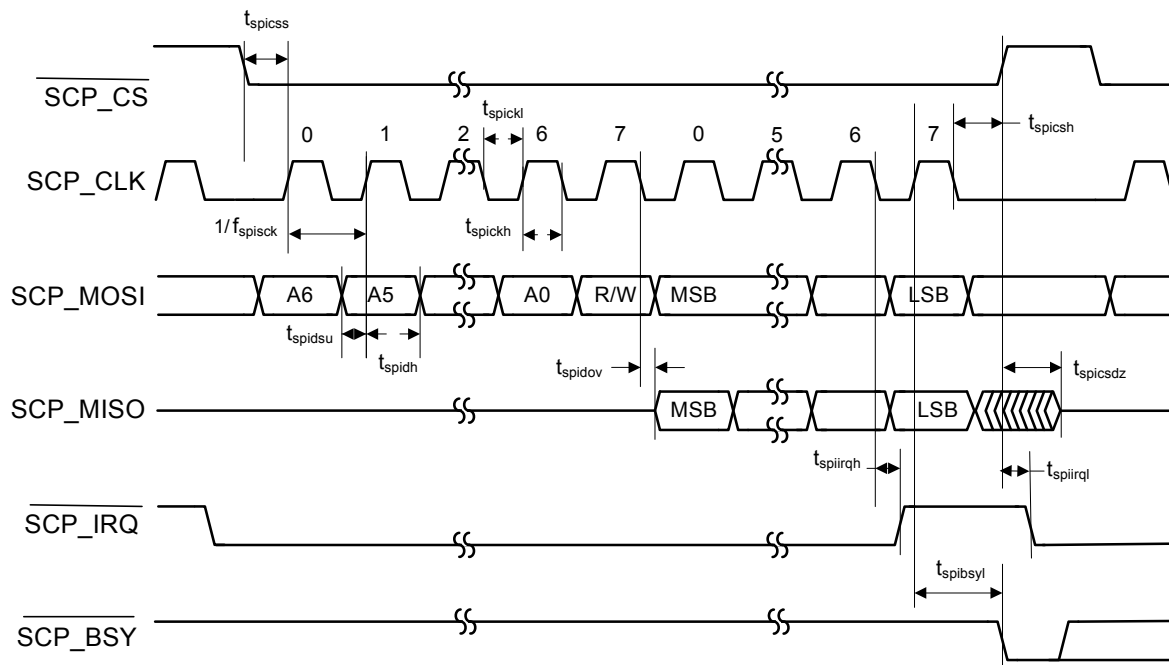

Figure 7. Serial Control Port - SPI Slave Mode Timing

5.10 Digital Switching Characteristics — Serial Control Port - SPI Master Mode

Parameter	Symbol	Min	Typical	Max	Units
SCP_CLK frequency ^{1,2}	f_{spisck}	-		$F_{\text{xtal}}/2$	MHz
$\overline{\text{EE_CS}}$ falling to SCP_CLK rising ³	t_{spicss}	-	$11 \cdot \text{DCLKP} + (\text{SCP_CLK PERIOD})/2$	-	ns
SCP_CLK low time	t_{spickl}	18		-	ns
SCP_CLK high time	t_{spickh}	18		-	ns
Setup time SCP_MISO input	t_{spidsu}	9		-	ns
Hold time SCP_MISO input	t_{spidh}	5		-	ns
SCP_CLK low to SCP_MOSI output valid	t_{spidov}	-		8	ns
SCP_CLK low to $\overline{\text{EE_CS}}$ falling	t_{spicsl}	7		-	ns
SCP_CLK low to $\overline{\text{EE_CS}}$ rising	t_{spicsh}	-	$11 \cdot \text{DCLKP} + (\text{SCP_CLK PERIOD})/2$	-	ns
Bus free time between active $\overline{\text{EE_CS}}$	t_{spicsx}		$3 \cdot \text{DCLKP}$	-	ns
SCP_CLK falling to SCP_MOSI output high-Z	t_{spidz}	-		20	ns

- f_{spisck} indicates the maximum speed of the hardware. The system designer should be aware that the actual maximum speed of the communication port may be limited by the firmware application.
- See [Section 5.7](#).
- SCP_CLK PERIOD refers to the period of SCP_CLK as being used in a given application. It does not refer to a tested parameter

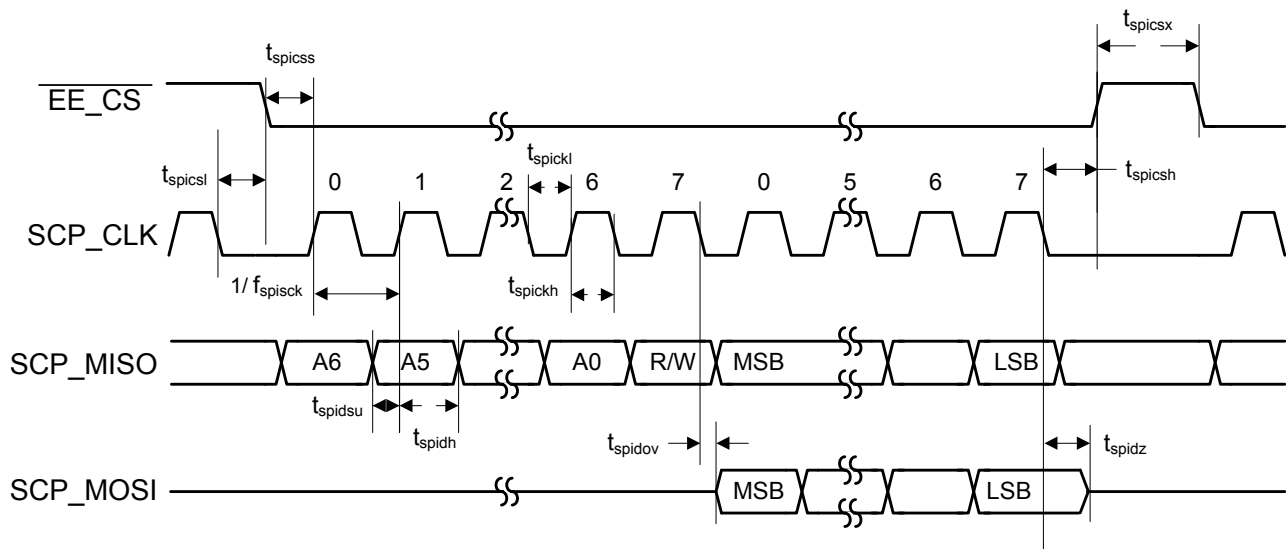

Figure 8. Serial Control Port - SPI Master Mode Timing

5.11 Digital Switching Characteristics — Serial Control Port - I²C Slave Mode

Parameter	Symbol	Min	Typical	Max	Units
SCP_CLK frequency ¹	f_{icck}	-		400	kHz
SCP_CLK rise time	t_{icr}			150	ns
SCP_CLK fall time	t_{icf}			150	ns
SCP_CLK low time	t_{icckl}	1.25		-	μ s
SCP_CLK high time	t_{icckh}	1.25		-	μ s
SCP_CLK rising to SCP_SDA rising or falling for START or STOP condition	$t_{icckcmd}$	1.25			μ s
START condition to SCP_CLK falling	t_{icstsc}	1.25		-	μ s
SCP_CLK falling to STOP condition	t_{icstp}	2.5		-	μ s
Bus free time between STOP and START conditions	t_{icbft}	3		-	μ s
Setup time SCP_SDA input valid to SCP_CLK rising	t_{icstu}	110			ns
Hold time SCP_SDA input after SCP_CLK falling	t_{ich}	100		-	ns
SCP_CLK low to SCP_SDA out valid	t_{icdov}	-		18	ns
SCP_CLK falling to $\overline{\text{SCP_IRQ}}$ rising	t_{icirqh}	-		$3 \cdot \text{DCLKP} + 40$	ns
NAK condition to $\overline{\text{SCP_IRQ}}$ low	t_{icirql}		$3 \cdot \text{DCLKP} + 20$		ns
SCP_CLK rising to $\overline{\text{SCP_BSY}}$ low	t_{icbsyl}	-	$3 \cdot \text{DCLKP} + 20$		ns

1. f_{icck} indicates the maximum speed of the hardware. The system designer should be aware that the actual maximum speed of the communication port may be limited by the firmware application. Flow control using the $\overline{\text{SCP_BSY}}$ pin should be implemented to prevent overflow of the input data buffer.

I²C Slave Address = 0x82

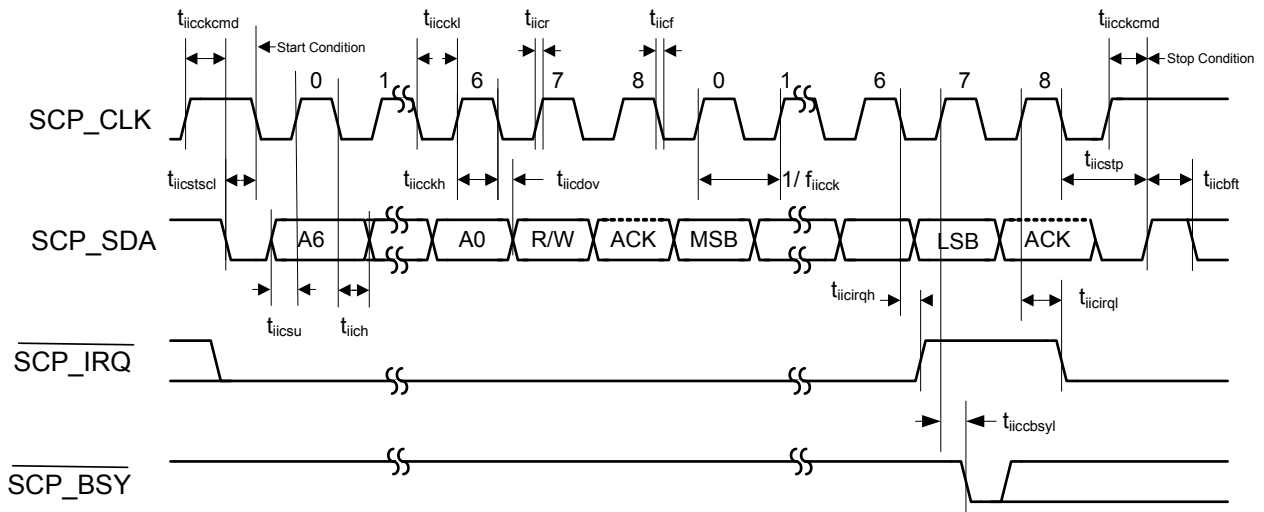

Figure 9. Serial Control Port - I²C Slave Mode Timing

5.12 Digital Switching Characteristics — Serial Control Port - I²C Master Mode

Parameter	Symbol	Min	Max	Units
SCP_CLK frequency ¹	f_{iicck}	-	400	kHz
SCP_CLK rise time	t_{iicr}	-	150	ns
SCP_CLK fall time	t_{iicf}	-	150	ns
SCP_CLK low time	t_{iicckl}	1.25	-	μ s
SCP_CLK high time	t_{iicckh}	1.25	-	μ s
SCP_CLK rising to SCP_SDA rising or falling for START or STOP condition	$t_{iicckcmd}$	1.25	-	μ s
START condition to SCP_CLK falling	$t_{iicstsc}$	1.25	-	μ s
SCP_CLK falling to STOP condition	t_{iicstp}	2.5	-	μ s
Bus free time between STOP and START conditions	t_{iicbft}	3	-	μ s
Setup time SCP_SDA input valid to SCP_CLK rising	t_{iicsu}	110	-	ns
Hold time SCP_SDA input after SCP_CLK falling	t_{iich}	100	-	ns
SCP_CLK low to SCP_SDA out valid	t_{iicdov}	-	36	ns

1. f_{iicck} indicates the maximum speed of the hardware. The system designer should be aware that the actual maximum speed of the communication port may be limited by the firmware application.

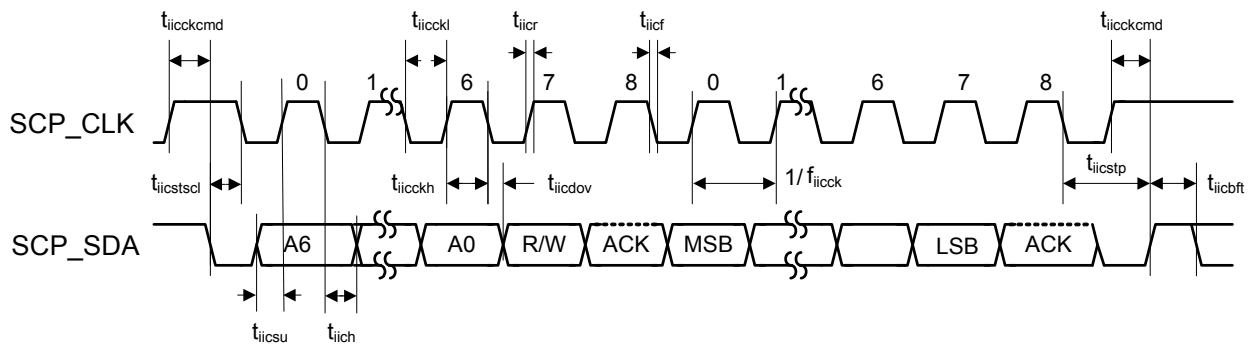

Figure 10. Serial Control Port - I²C Master Mode Timing

5.13 Digital Switching Characteristics — Digital Audio Slave Input Port

Parameter	Symbol	Min	Max	Unit
DAI_SCLK period	$T_{daiclkp}$	20	-	ns
DAI_SCLK duty cycle	-	45	55	%
Setup time DAI_DATAn	t_{daidsu}	8	-	ns
Hold time DAI_DATAn	t_{daidh}	5	-	ns

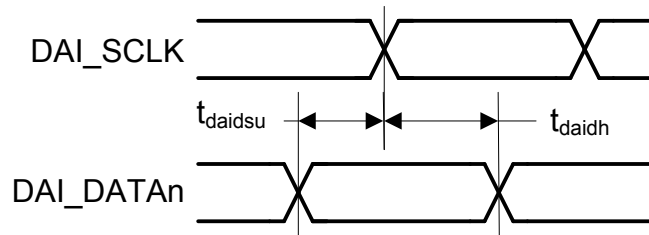

Figure 11. Digital Audio Input (DAI) Port Timing Diagram

5.14 Digital Switching Characteristics — Digital Audio Output Port

Parameter	Symbol	Min	Max	Unit
DAO_MCLK period	$T_{daomclk}$	20	-	ns
DAO_MCLK duty cycle	-	45	55	%
DAO_SCLK period for Master or Slave mode ¹	$T_{daosclk}$	20	-	ns
DAO_SCLK duty cycle for Master or Slave mode ¹	-	40	60	%
Master Mode (Output A1 Mode)^{1,2}				
DAO_SCLK delay from DAO_MCLK rising edge, DAO_MCLK as an input	$t_{daomsck}$	-	19	ns
DAO_LRCLK to DAO_SCLK non-active edge ³ . See Figure 12A.	$t_{daomlrts}$	-	8	ns
DAO_SCLK non-active edge ³ to DAO_LRCLK, See Figure 12B.	$t_{daomstlr}$	-	8	ns
DAO_DATA[3:0] delay from DAO_SCLK non-active edge ³	t_{daomdv}	-	8	ns
Slave Mode (Output A0 Mode)⁴				
DAO_LRCLK to DAO_SCLK non-active edge ^{3,5} See Figure 13A.	$t_{daoslrts}$	-	15	ns
DAO_SCLK non-active edge ^{3,5} to DAO_LRCLK, See Figure 13B.	$t_{daosstlr}$	-	30	ns
DAO1_DATA[3.0] delay from DAO_SCLK non-active edge ³	t_{daosdv}	-	8	ns

1. Master mode timing specifications are characterized, not production tested.
2. Master mode is defined as the CS47048 driving both DAO_SCLK, DAO_LRCLK. When MCLK is an input, it is divided to produce DAO_SCLK, DAO_LRCLK.
3. The DAO_LRCLK transition may occur on either side of the non-active edge of DAO_LRCLK. The active edge of DAO_SCLK is the point at which the data is valid.
4. Slave mode is defined as DAO_SCLK, DAO_LRCLK driven by an external source.
5. These Max values for $t_{daoslrts}$ and $t_{daosstlr}$ apply to applications where a 1/2 period of DAO_SCLK exceeds one of the maximum delays.

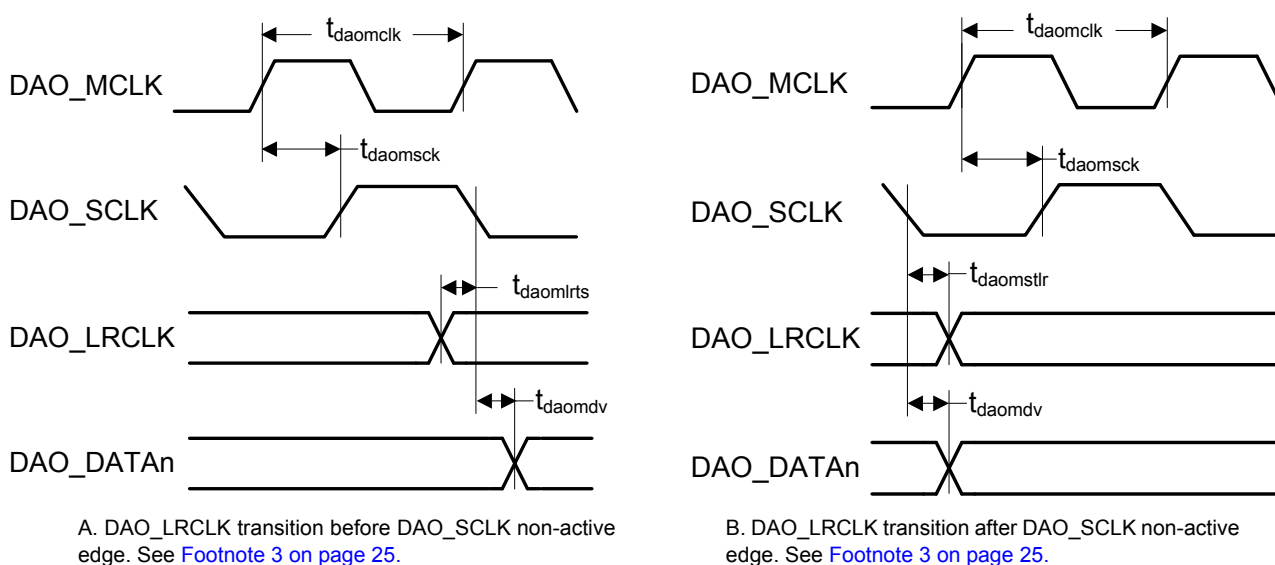
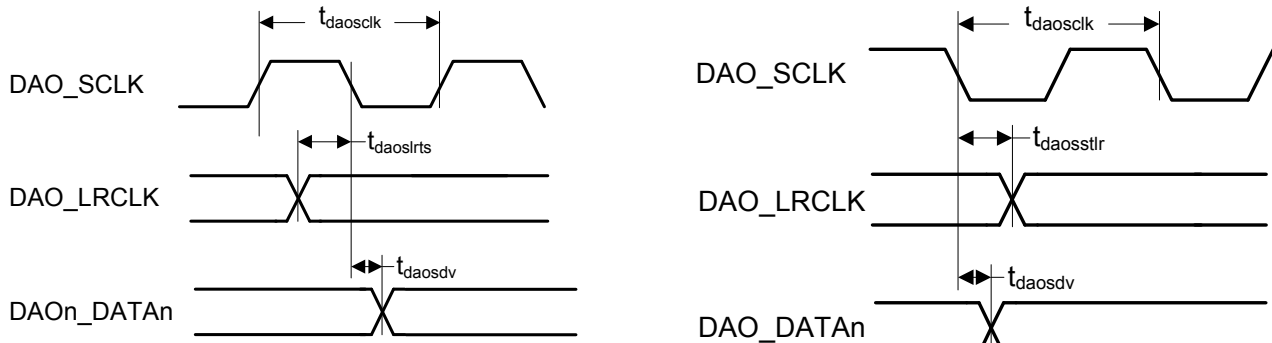

Figure 12. Digital Audio Output Port Timing, Master Mode



A. DAO_LRCLK transition before DAO_SCLK non-active edge. See [Footnote 3 on page 25](#).

B. DAO_LRCLK transition after DAO_SCLK non-active edge. See [Footnote 3 on page 25](#).

Figure 13. Digital Audio Output Port Timing, Slave Mode

5.15 Digital Switching Characteristics — S/PDIF RX Port

(Inputs: Logic 0 = V_{IL} , Logic 1 = V_{IH} ; $C_L = 20$ pF)

Parameter	Symbol	Min	Typ	Max	Units
PLL Clock Recovery Sample Rate Range		30	-	200	kHz

5.16 ADC Characteristics

5.16.1 Analog Input Characteristics (Commercial)

Test Conditions (unless otherwise specified): $T_A = 0$ to $+70^\circ\text{C}$; $V_{DD} = 1.8\text{V}\pm 5\%$, $V_{DDA} (V_A) = 3.3\text{V}\pm 5\%$; 1 kHz sine wave driven through the passive input filter ($R_i = 10\text{ k}\Omega$) in [Figure 14 on page 29](#) or [Figure 15 on page 29](#); DSP running test application; Measurement Bandwidth is 10 Hz to 20 kHz.

Parameter	Differential			Single-Ended			Unit	
	Min	Typ	Max	Min	Typ	Max		
Fs= 96 kHz								
Dynamic Range ^{1,6,7}	A-weighted	99	105	-	96	102	-	dB
	unweighted	96	102	-	93	99	-	dB
	40 kHz bandwidth unweighted	-	99	-	-	96	-	dB
Total Harmonic Distortion + Noise ^{6,7}	-1 dB	-	-98	-92	-	-95	-89	dB
	-20 dB	-	-82	-	-	-79	-	dB
	-60 dB	-	-42	-	-	-39	-	dB
	40 kHz bandwidth -1 dB	-	-90	-	-	-90	-	dB
AIN_1A/B Interchannel Isolation ¹⁰	-	95	-	-	95	-	dB	
AIN_[2.6]A/B MUX Interchannel Isolation	-	95	-	-	95	-	dB	
DC Accuracy								
Interchannel Gain Mismatch	-	0.1	-	-	0.1	-	dB	
Gain Drift	-	± 120	-	-	± 120	-	ppm/ $^\circ\text{C}$	
Analog Input								
Full-Scale Input Voltage ^{2,3}	3.3	$3.7 \cdot V_A$	3.9	1.65	$1.85 \cdot V_A$	1.95	V_{PP}	
Differential Input Impedance ⁴	-	400	-	-	-	-	Ω	
Single-Ended Input Impedance ⁵	-	-	-	-	200	-	Ω	
Common Mode Rejection Ratio (CMRR) ⁸	-	60	-	-	-	-	dB	
Parasitic Load Capacitance (C_L) ⁹	-	-	20	-	-	20	pF	

1. dB units referred to the typical full-scale voltage.
2. These full-scale values were measured with $R_i = 10\text{ k}\Omega$ for both the single-ended and differential mode input circuits.
3. The full-scale voltage can be changed by scaling R_i .
 Differential Full-Scale (V_{pp}) = $3.7 \cdot V_{DDA} \cdot (R_i + 200) / (10\text{ k} + 200)$
 Single-Ended Full-Scale (V_{pp}) = $1.85 \cdot V_{DDA} \cdot (R_i + 200) / (10\text{ k} + 200)$
4. Measured between AIN_xx+ and AN_xx-.
5. Measured between AIN_xx+ and AGND.
6. Decreasing Full-Scale voltage by reducing R_i will cause the noise floor to increase.
7. Common mode input current should be kept to less than $\pm 160\mu\text{A}$ to avoid performance degradation: $|(I_{ip} + I_{in})/2| < 160\mu\text{A}$. This corresponds to $\pm 1.6\text{V}$ for $R_i = 10\text{ k}\Omega$ in the differential case.
8. This number was measured using perfectly matched external resistors (R_i). Mismatch in the external resistors will typically reduce CMRR by $20 \log(|\Delta R_i|/R_i + 0.001)$.
9. C_L represents the parasitic load capacitance between R_i on the input circuit and the input pin of the CS47048 package.
10. This measurement is not applicable to the CS47028 and CS47024 devices.

5.16.2 Analog Input Characteristics (Automotive)

Test Conditions (unless otherwise specified): $T_A = -40$ to $+85^\circ\text{C}$; $V_{DD} = 1.8\text{V}\pm 5\%$, V_{DDA} (V_A) = $3.3\text{V}\pm 5\%$; 1 kHz sine wave driven through the passive input filter ($R_i=10\text{ k}\Omega$) in [Figure 14 on page 29](#) or [Figure 15 on page 29](#); DSP running test application; Measurement Bandwidth is 10 Hz to 20 kHz.

Parameter	Differential			Single-Ended			Unit	
	Min	Typ	Max	Min	Typ	Max		
Fs=96 kHz								
Dynamic Range ^{1,6,7}	A-weighted	97	105	-	94	102	-	dB
	unweighted	94	102	-	91	99	-	dB
	40 kHz bandwidth unweighted	-	99	-	-	96	-	dB
Total Harmonic Distortion + Noise ^{6,7}	-1 dB	-	-98	-90	-	-95	-87	dB
	-20 dB	-	-82	-	-	-79	-	dB
	-60 dB	-	-42	-	-	-39	-	dB
	40 kHz bandwidth -1 dB	-	-90	-	-	-90	-	dB
AIN_1A/B Interchannel Isolation ¹⁰	-	95	-	-	95	-	dB	
AIN_[2.6]A/B MUX Interchannel Isolation	-	95	-	-	95	-	dB	
DC Accuracy								
Interchannel Gain Mismatch	-	0.1	-	-	0.1	-	dB	
Gain Drift	-	± 120	-	-	± 120	-	ppm/ $^\circ\text{C}$	
Analog Input								
Full-Scale Input Voltage ^{2,3}	3.3	$3.7 \cdot V_A$	3.9	1.65	$1.85 \cdot V_A$	1.95	V_{PP}	
Differential Input Impedance ⁴	-	400	-	-	-	-	Ω	
Single-Ended Input Impedance ⁵	-	-	-	-	200	-	Ω	
Common Mode Rejection Ratio (CMRR) ⁸	-	60	-	-	-	-	dB	
Parasitic Load Capacitance (C_L) ⁹	-	-	20	-	-	20	pF	

Notes:

1. dB units referred to the typical full-scale voltage.
2. These full-scale values were measured with $R_i=10\text{ k}\Omega$ for both the single-ended and differential mode input circuits.
3. The full-scale voltage can be changed by scaling R_i .
 Differential Full-Scale (V_{pp}) = $3.7 \cdot V_{DDA} \cdot (R_i + 200) / (10\text{ k} + 200)$
 Single-Ended Full-Scale (V_{pp}) = $1.85 \cdot V_{DDA} \cdot (R_i + 200) / (10\text{ k} + 200)$
4. Measured between AIN_xx+ and AN_xx-.
5. Measured between AIN_xx+ and AGND.
6. Decreasing Full-Scale voltage by reducing R_i will cause the noise floor to increase.
7. Common mode input current should be kept to less than $\pm 160\mu\text{A}$ to avoid performance degradation: $|(I_{ip} + I_{in})/2| < 160\mu\text{A}$. This corresponds to $\pm 1.6\text{V}$ for $R_i=10\text{ k}\Omega$ in the differential case.
8. This number was measured using perfectly matched external resistors (R_i). Mismatch in the external resistors will typically reduce CMRR by $20 \log(|\Delta R_i|/R_i + 0.001)$.
9. C_L represents the parasitic load capacitance between R_i on the input circuit and the input pin of the CS47048 package.
10. This measurement is not applicable to the CS47028 and CS47024 devices.

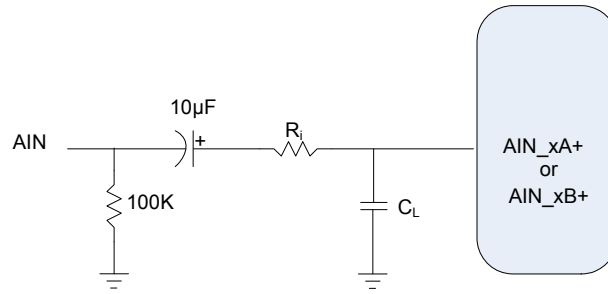

Figure 14. ADC Single-Ended Input Test Circuit

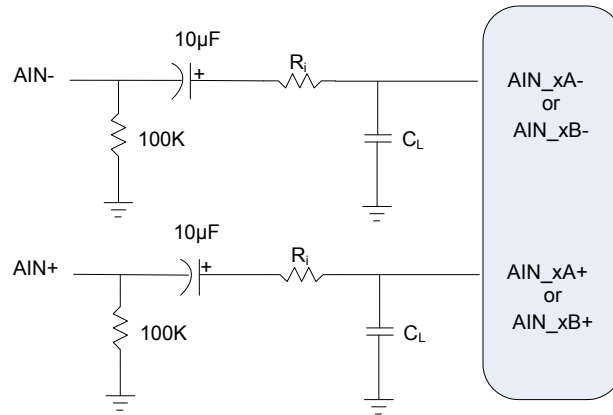

Figure 15. ADC Differential Input Test Circuit

5.16.3 ADC Digital Filter Characteristics

Parameter ^{1, 2}	Min	Typ	Max	Unit
<i>Fs = 96 kHz</i>				
Passband (Frequency Response) to -0.1 dB corner	0	-	0.4896	Fs
Passband Ripple	-	-	0.08	dB
Stopband	0.5688	-	-	Fs
Stopband Attenuation	70	-	-	dB
Total Group Delay	-	12/Fs	-	s
<i>High-Pass Filter Characteristics</i>				
Frequency Response-3.0 dB	-	1	-	Hz
-0.13 dB	-	20	-	Hz
Phase Deviation @ 20 Hz	-	10	-	Deg
Passband Ripple	-	-	0	dB
Filter Settling Time	-	10 ⁵ /Fs	0	s

Notes:

1. Filter response is guaranteed by design.
2. Response is clock-dependent and will scale with Fs.

5.17 DAC Characteristics

5.17.1 Analog Output Characteristics (Commercial)

Test Conditions (unless otherwise specified): T_A = 0 to +70°C; VDD = 1.8V±5%, VDDA(VA) = 3.3V±5%; 1 kHz sine wave driven through a filter shown in [Figure 16 on page 31](#) or [Figure 17 on page 32](#); DSP running test application; Measurement Bandwidth is 20 Hz to 20 kHz.

Parameter	Differential			Single-Ended			Unit	
	Min	Typ	Max	Min	Typ	Max		
<i>Fs = 96 kHz</i>								
Dynamic Range	A-weighted	102	108	-	99	105	-	dB
	unweighted	99	105	-	96	102	-	dB
Total Harmonic Distortion + Noise	0 dB	-	-98	-90	-	-95	-87	dB
	-20 dB	-	-88	-	-	-85	-	dB
	-60 dB	-	-48	-	-	-45	-	dB
Interchannel Isolation (1 kHz)	-	95	-	-	95	-	dB	
<i>Analog Output</i>								
Full-Scale Output	1.20	1.40•VA	1.60	0.60	0.70•VA	0.80	V _{PP}	
Interchannel Gain Mismatch	-	0.1	-	-	0.1	-	dB	
Gain Drift	-	±120	-	-	±120	-	ppm/°C	
Output Impedance	-	100	-	-	100	-	Ω	
DC Current draw from an AOUT pin ¹	-	-	10	-	-	10	μA	
AC-Load Resistance (R _L) ²	3	-	-	3	-	-	kΩ	
Load Capacitance (C _L) ²	-	-	100	-	-	100	pF	

5.17.2 Analog Output Characteristics (Automotive)

Test Conditions (unless otherwise specified): $T_A = -40$ to $+85^\circ\text{C}$; $V_{DD} = 1.8\text{V}\pm 5\%$, $V_{DDA}(\text{VA}) = 3.3\text{V}\pm 5\%$; 1 kHz sine wave driven through a filter shown in [Figure 16 on page 31](#) or [Figure 17 on page 32](#); DSP running test application; Measurement Bandwidth is 20 Hz to 20 kHz.

Parameter	Differential			Single-Ended			Unit	
	Min	Typ	Max	Min	Typ	Max		
$F_s = 96$ kHz								
Dynamic Range	A-weighted	100	108	-	97	105	-	dB
	unweighted	97	105	-	94	102	-	dB
Total Harmonic Distortion + Noise	0 dB	-	-98	-90	-	-95	-87	dB
	-20 dB	-	-88	-	-	-85	-	dB
	-60 dB	-	-48	-	-	-45	-	dB
Interchannel Isolation (1 kHz)	-	95	-	-	95	-	dB	
Analog Output								
Full-Scale Output	1.20	$1.40 \cdot V_A$	1.60	0.60	$0.70 \cdot V_A$	0.80	V_{PP}	
Interchannel Gain Mismatch	-	0.1	-	-	0.1	-	dB	
Gain Drift	-	± 120	-	-	± 120	-	ppm/ $^\circ\text{C}$	
Output Impedance	-	100	-	-	100	-	Ω	
DC Current draw from an AOUT pin ¹	-	-	10	-	-	10	μA	
AC-Load Resistance (R_L) ²	3	-	-	3	-	-	k Ω	
Load Capacitance (C_L) ²	-	-	100	-	-	100	pF	

Notes:

1. Guaranteed by design. The DC current draw represents the allowed current draw from the AOUT pin due to typical leakage through the electrolytic DC-blocking capacitors.
2. Guaranteed by design. R_L and C_L reflect the recommended minimum resistance and maximum capacitance required for the internal op-amp's stability and signal integrity. In this circuit topology, C_L represents any capacitive loading that appears *before* the 560Ω series resistor (typically parasitic), and will effectively move the dominant pole of the two-pole amp in the output stage. Increasing this value beyond the recommended 100 pF can cause the internal op-amp to become unstable.

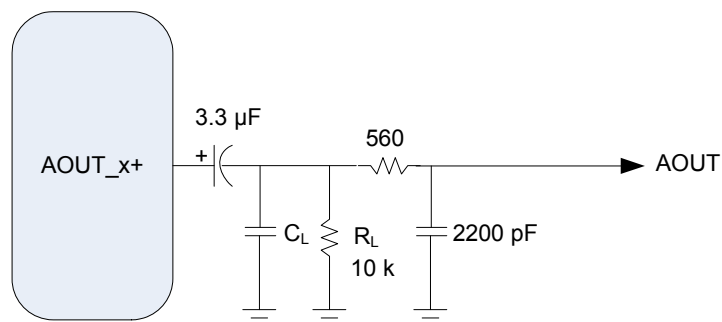
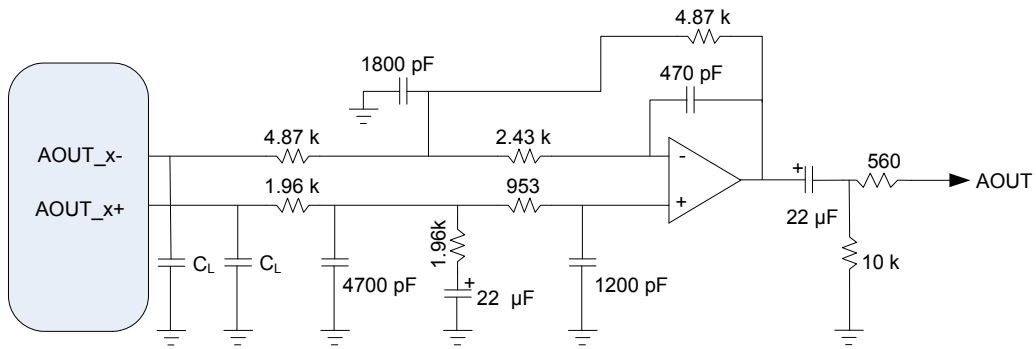

Figure 16. DAC Single-Ended Output Test Circuit



P output: $R_L = 1.96k + ([2\pi F \cdot 4700pF]^{-1} \parallel (1.96k + [2\pi F \cdot 22\mu F]^{-1}) \parallel (953 + [2\pi F \cdot 1200pF]^{-1}))$
 N output: $R_L = 4.87k + ([2\pi F \cdot 1800pF]^{-1} \parallel ((2.43k + [2\pi F \cdot 470pF]^{-1}) \parallel 4.87k))$

Figure 17. DAC Differential Output Test Circuit

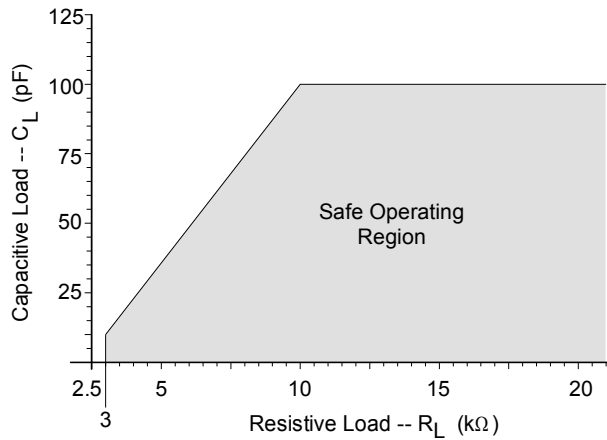

Figure 18. Maximum Loading

5.17.3 Combined DAC Interpolation & On-chip Analog Filter Response

Parameter	Min	Typ	Max	Unit
Passband (Frequency Response)	0	-	0.4125	Fs
	0	-	0.4979	Fs
Frequency Response 10 Hz to 20 kHz	-0.02	-	+0.02	dB
StopBand	0.5465	-	-	Fs
StopBand Attenuation	100	-	-	dB
Group Delay	-	10/Fs	-	s

6. Ordering Information

The CS470xx DSP part numbers are described as follows:

Example :

CS47048I-XYZR

where

I - ROM ID Letter

X - Product Grade

Y - Package Type

Z - Lead (Pb) Free

R - Tape and Reel Packaging

Table 5. Ordering Information

Part No.	Grade	Temp. Range	Package
CS47048C-CQZ	Commercial	0 to +70 °C	100-pin LQFP
CS47048C-DQZ	Automotive	-40 to +85 °C	
CS47028C-CQZ	Commercial	0 to +70 °C	
CS47028C-DQZ	Automotive	-40 to +85 °C	
CS47024C-CQZ	Commercial	0 to +70 °C	
CS47024C-DQZ	Automotive	-40 to +85 °C	

NOTE: Please contact the factory for availability of the -D (automotive grade) package.

7. Environmental, Manufacturing, & Handling Information

Table 6. Environmental, Manufacturing, and Handling Information

Model Number	Peak Reflow Temp	MSL Rating*	Max Floor Life
CS47048C-CQZ	260 °C	3	7 days
CS47048C-DQZ			
CS47028C-CQZ	260 °C	3	7 days
CS47028C-DQZ			
CS47024C-CQZ	260 °C	3	7 days
CS47024C-DQZ			

* MSL (Moisture Sensitivity Level) as specified by IPC/JEDEC J-STD-020.

8. Device Pinout Diagram

8.1 CS47048, 100-Pin LQFP Pinout Diagram

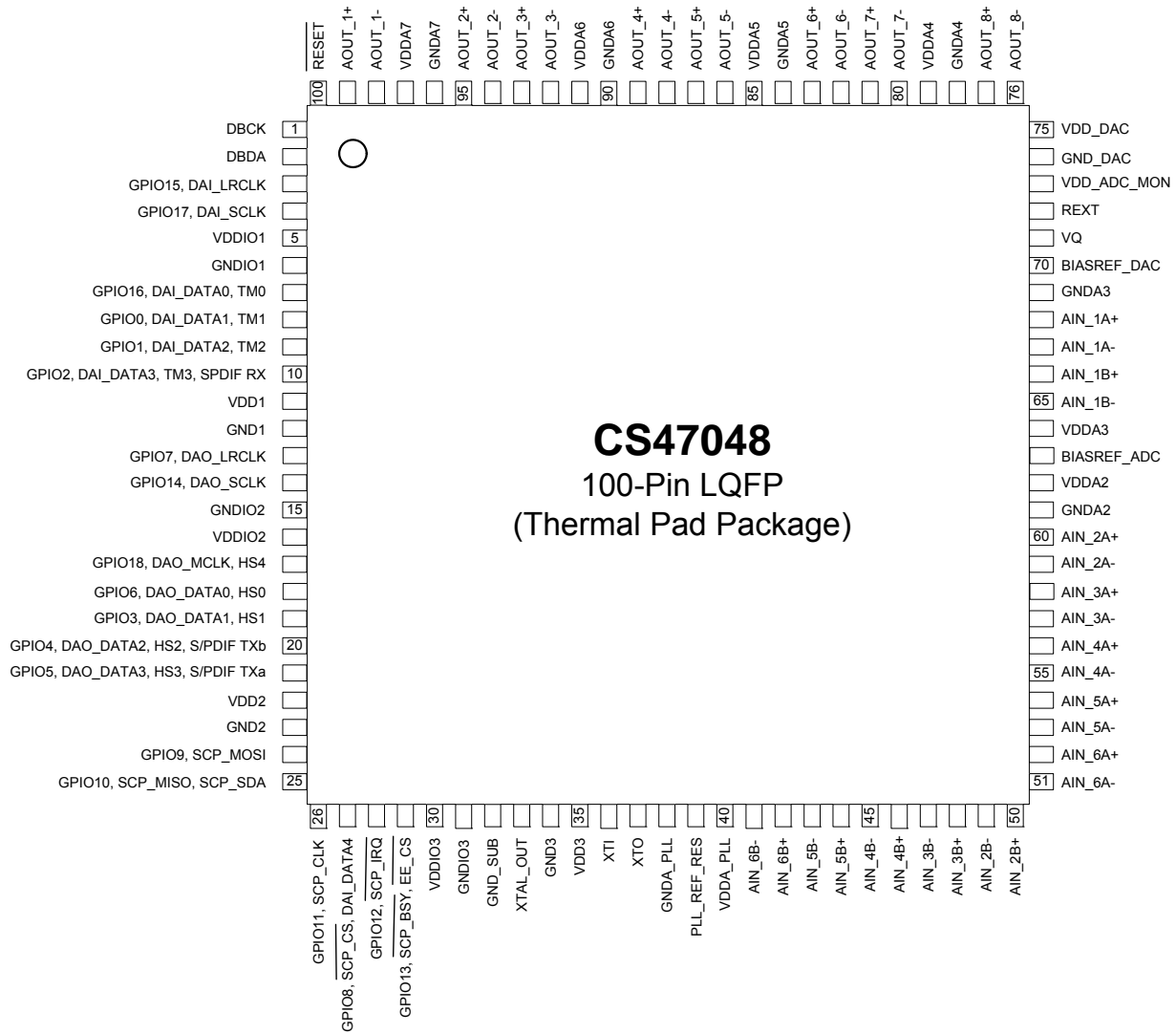

Figure 19. CS47048 Pinout Diagram

8.2 CS47028, 100-Pin LQFP Pinout Diagram

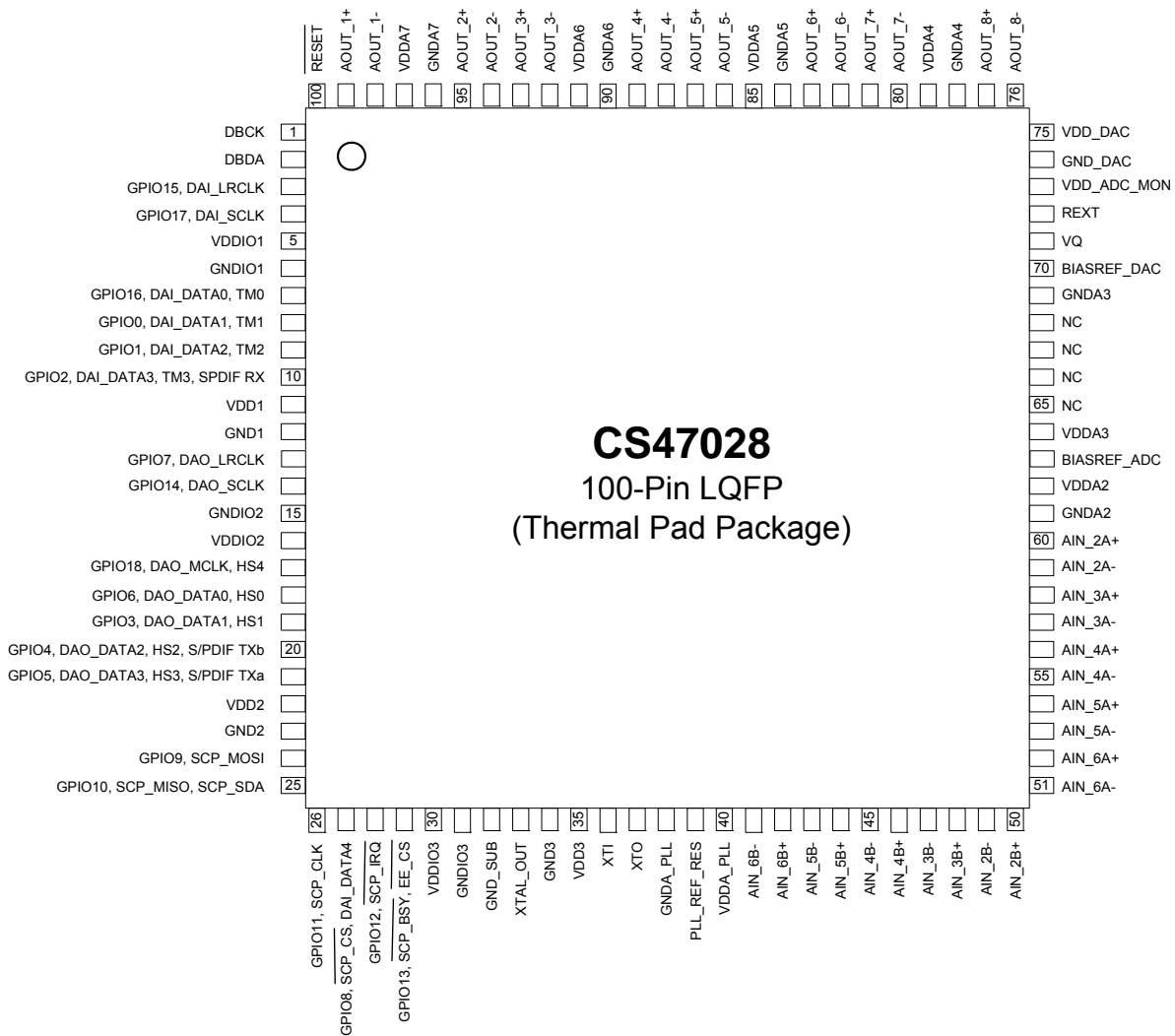

Figure 20. CS47028 Pinout Diagram

8.3 CS47024, 100-Pin LQFP Pinout Diagram

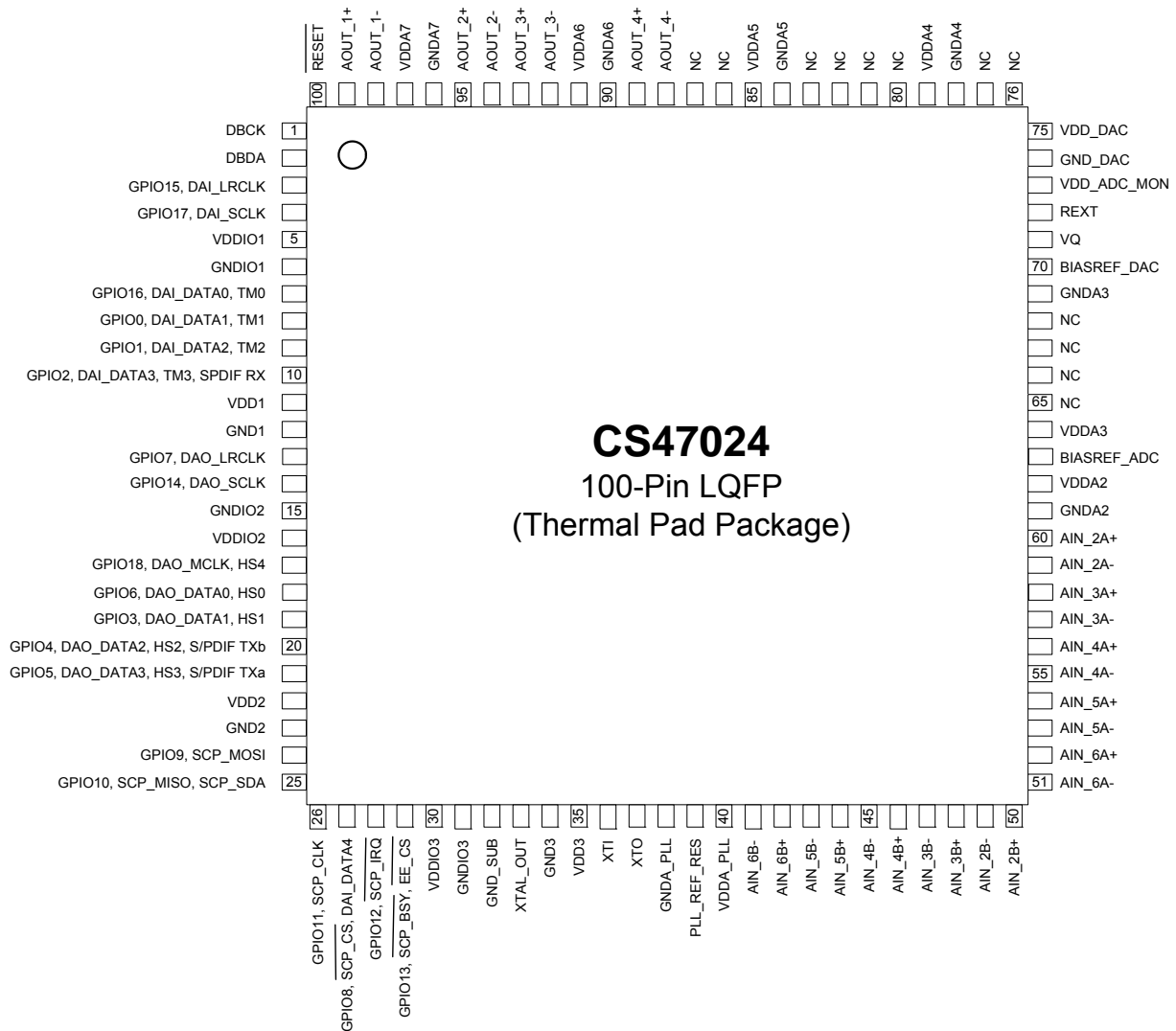

Figure 21. CS47024 Pinout Diagram

9. 100-pin LQFP with Exposed Pad Package Drawing

Figure 22 shows the 100-pin LQFP package with exposed pad for the CS47048, CS47028, and CS47024.

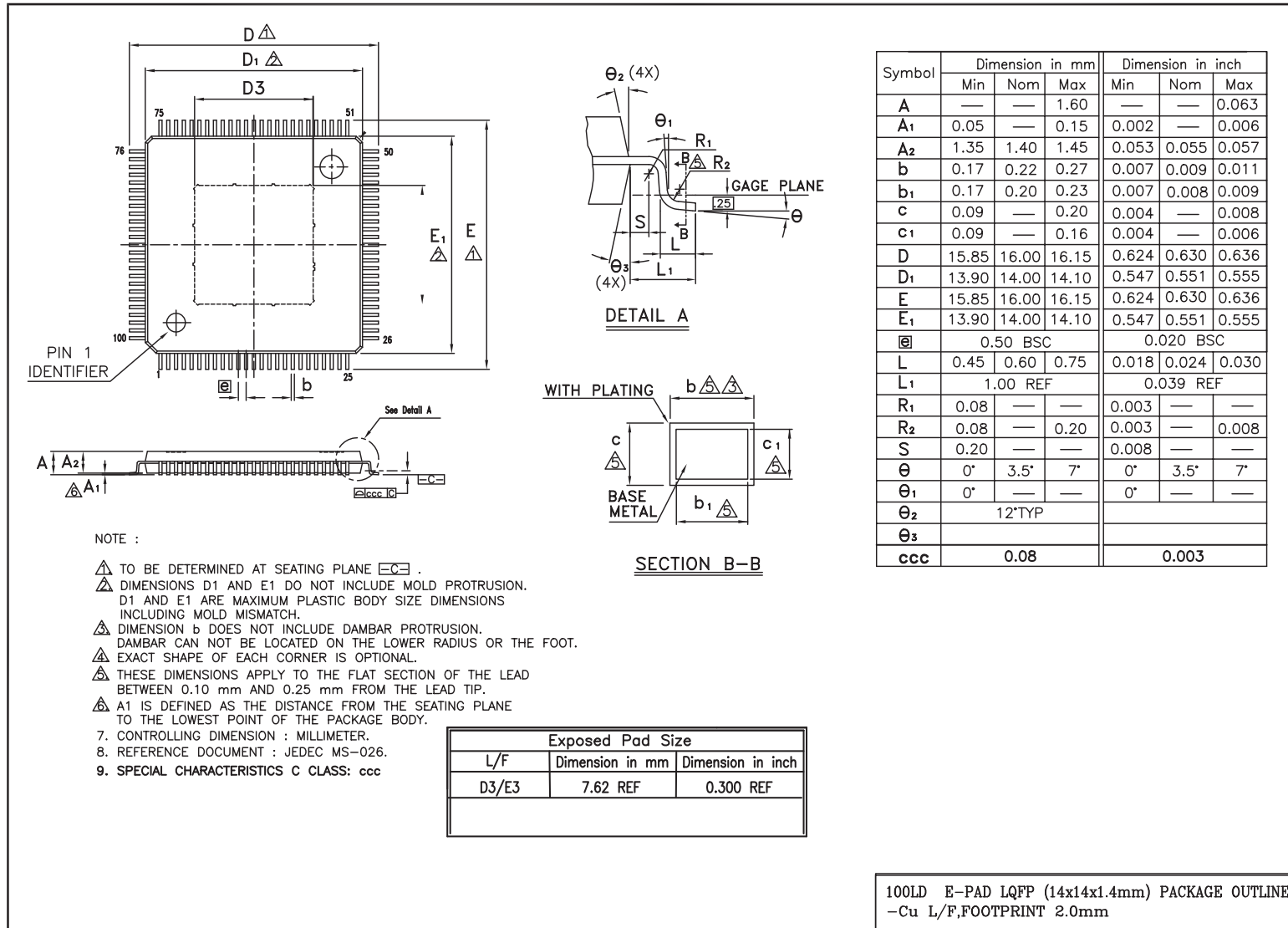

Figure 22. 100-Pin LQFP Package Drawing

10. Parameter Definitions

10.1 Dynamic Range

The ratio of the RMS value of the signal to the RMS sum of all other spectral components over the specified bandwidth. Dynamic Range is a signal-to-noise ratio measurement over the specified bandwidth made with a -60 dBFS signal. 60 dB is added to resulting measurement to refer the measurement to full-scale. This technique ensures that the distortion components are below the noise level and do not affect the measurement. This measurement technique has been accepted by the Audio Engineering Society, AES17-1991, and the Electronic Industries Association of Japan, EIAJ CP-307. Expressed in decibels.

10.2 Total Harmonic Distortion + Noise

The ratio of the RMS value of the signal to the RMS sum of all other spectral components over the specified bandwidth (typically 10 Hz to 20 kHz), including distortion components. Expressed in decibels. Measured at -1 and -20 dBFS as suggested in AES17-1991 Annex A.

10.3 Frequency Response

A measure of the amplitude response variation from 10 Hz to 20 kHz relative to the amplitude response at 1 kHz. Units in decibels.

10.4 Interchannel Isolation

A measure of crosstalk between the left and right channels. Measured for each channel at the converter's output with no signal to the input under test and a full-scale signal applied to the other channel. Units in decibels.

10.5 Interchannel Gain Mismatch

The gain difference between left and right channels. Units in decibels.

10.6 Gain Error

The deviation from the nominal full-scale analog output for a full-scale digital input.

10.7 Gain Drift

The change in gain value with temperature. Units in ppm/°C.

11. Revision History

Revision	Date	Changes
A7	October 16, 2008	Initial Release
A8	March 22, 2009	Added CS47028 and CS47024 products to the data sheet. Changed name of data sheet to <i>CS470xx Data Sheet</i> . Added note regarding necessity of power supplies being stable before $\overline{\text{RESET}}$ goes high to Section 5.6 .
A9	April 22, 2009	Updated Table 2 and Table 3 . Updated timing diagram in Figure 4 and added Figure 5 . Updated Figure 14 , Figure 15 , Figure 16 , and Figure 17 . Characterization data for Standby Power Supply Current: reported as TBD until final measurements are completed. Formula in Note 3 on page 27 and Note 3 on page 28 have been restated for greater clarity. Min and Max values for Full-Scale input Voltage in Section 5.16.1 and Section 5.16.2 reported as TBD until final measurements are completed.
A10	April 28, 2009	Updated Section 5.10 , replacing references to $\overline{\text{SCP_CS}}$ with $\overline{\text{EE_CS}}$.
A11	April 29, 2009	Updated ordering numbers in Table 5 and Table 6 . Updated characterization data for Analog Full-Scale Output Voltage, Typical, for both Differential and Single-ended signals in Section 5.16.1 , Section 5.16.2 , Section 5.17.1 , and Section 5.17.2 .
PP1	August 3, 2009	Updated Characterization data in Section 5.4 , Section 5.7 , Section 5.9 , Section 5.11 , Section 5.12 , Section 5.16.1 , Section 5.16.2 , Section 5.16.3 , Section 5.17.1 , and Section 5.17.2 . Modified Footnote 3 in both Section 5.16.1 and Section 5.16.2 . Added Footnote 5 to Section 5.14 . Updated Section 2. . Modified Section 4.3.6 and Section 4.3.8 . Modified references to TDM in various sections of the data sheet. Use the search function in the Adobe PDF Reader™ to find all instances where TDM is described in this data sheet.
PP2	January 20, 2010	Updated TDM Feature description on page 1 . Modified note at the bottom of the feature list on page 1 . Updated table in Section 5.8 , specifying performance data for 2- and 4-layer boards. Updated Table 2 and Table 3 . Updated block diagrams in Figure 1 , Figure 2 , and Figure 3 .

Revision	Date	Changes
PP3	June 10, 2010	<p>Table 2: Straddled all three columns in the “Supports Different Fs Sample Rates” row to indicate that CS47024 devices have the same features as the CS47048 and CS47028.</p> <p>Added “The CS47024 has the 8-channel SRC block” to Section 4.3.7.</p> <p>Added text in the following places to indicate that the CS47024 implements the S/PDIF Rx functionality:</p> <ul style="list-style-type: none"> • Removed dagger from the S/PDIF Rx bullet on p. 1. • Updated bullet in “Configurable Serial Audio Inputs/Outputs” row in Table 2 Integrated 192 kHz S/PDIF Rx, 2 Integrated 192 kHz S/PDIF Tx. • Changed entry in “S/PDIF In (Stereo Pairs)” column in Table 3. • Updated I2S block in Table 3. • Removed text “On the CS47048 and CS47028...” from Section 4.3.4. • Removed “(Not available on CS47024)” from the heading to Section 5.15. <p>Described additional support for TDM 8-channel output mode on CS47024:</p> <ul style="list-style-type: none"> • Removed dagger from the TDM I/O bullet on p. 1. • Straddled “Configurable Serial Audio Inputs/Outputs” row in Table 2. • Changed cell in “TDM Out” column in Table 3. • Removed text “On the CS47048 and CS47028...” from Section 4.3.5.
PP4	Feb. 10, 2011	<p>Added “Decoder” information to Section 3. Changed the name of the core to “Cirrus Logic 32-bit core”.</p>
PP5	Feb. 21, 2011	<p>Added “SPDIF RX” to Figure 21.</p>