

THIS DOCUMENT IS THE PROPERTY OF
KEYSTONE ELECTRONICS CORP. AND
SHALL NOT BE REPRODUCED, DISTRIBUTED
OR USED AS A BASIS FOR MANUFACTURE
WITHOUT PRIOR WRITTEN PERMISSION
FROM KEYSTONE ELECTRONICS CORP.

MOUNTING DETAIL

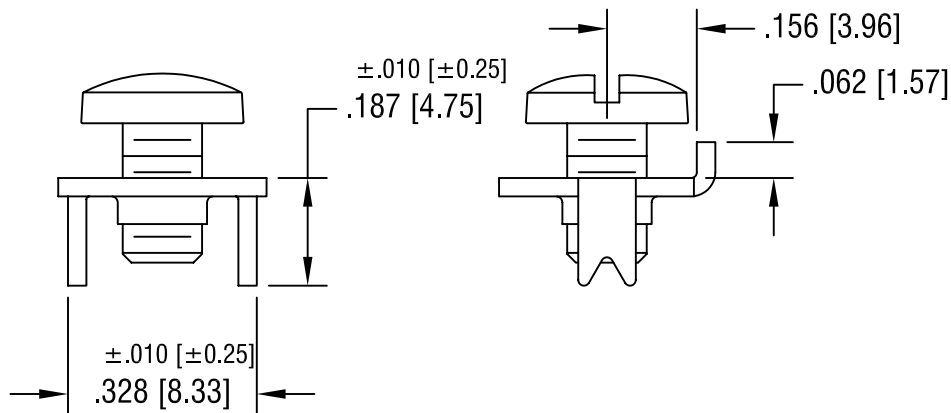
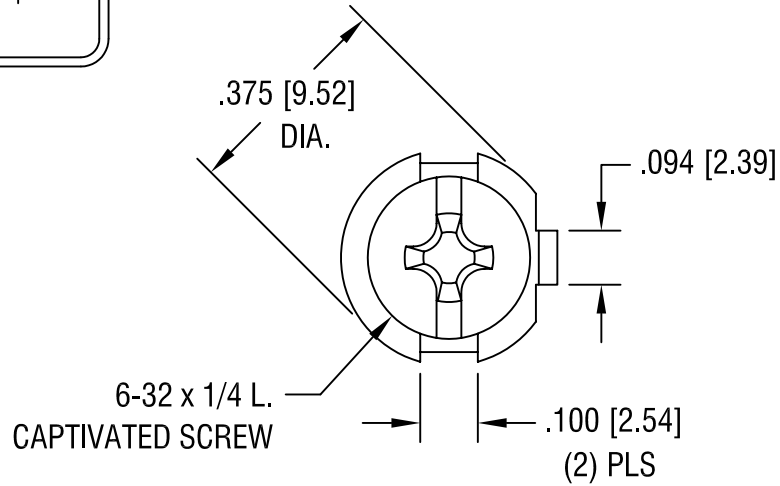
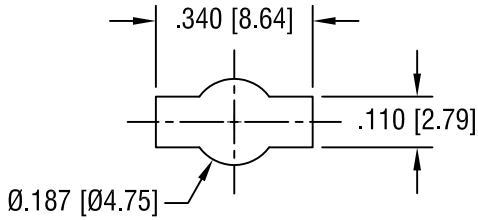

NOTES:

1. TERMINAL:

MAT'L - .032 [0.81] TH'K BRASS, TIN PLATE

SCREW:

MAT'L - STAINLESS STEEL
FINISH - NONE

KEYSTONE ELECTRONICS CORP.

ASTORIA, N.Y. 11105-2017

| | | | |
|----------------------------|-----------------|----------------|---------|
| PART NAME | | SCREW TERMINAL | |
| MATERIAL | | AS NOTED | |
| FINISH | AS NOTED | DRN BY | BOONE |
| | | APP'D | SCALE |
| | | | 3X |
| TOLERANCES | INCH [MM] | CODE | DWG NO. |
| DECIMAL | ± .005 [± 0.15] | C | 1201 |
| ANGULAR | ± 1° | | |
| UNLESS OTHERWISE SPECIFIED | | | |

| | | |
|----------|--------------------------|------|
| 12.28.07 | CHANGE AS PER ECN 07-099 | B |
| DATE | DESCRIPTION | REV. |