

DATE	DESCRIPTION	REV.
8.24.10	CHANGE AS PER ECN 10-062	A
10.04.10	CHANGE PER ECN 10-069	B
10.26.10	CHANGE PER ECN 10-075	C

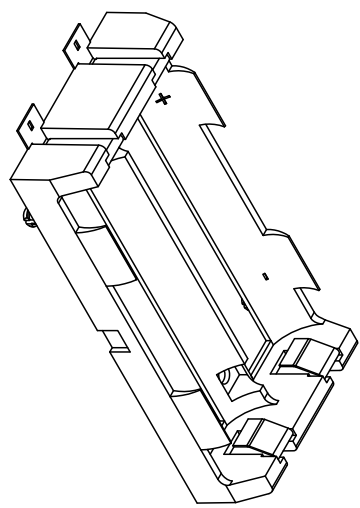
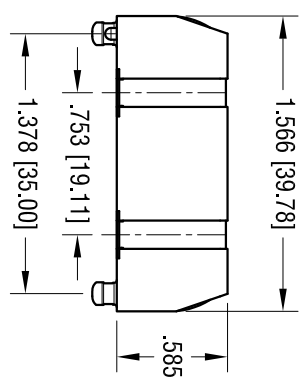
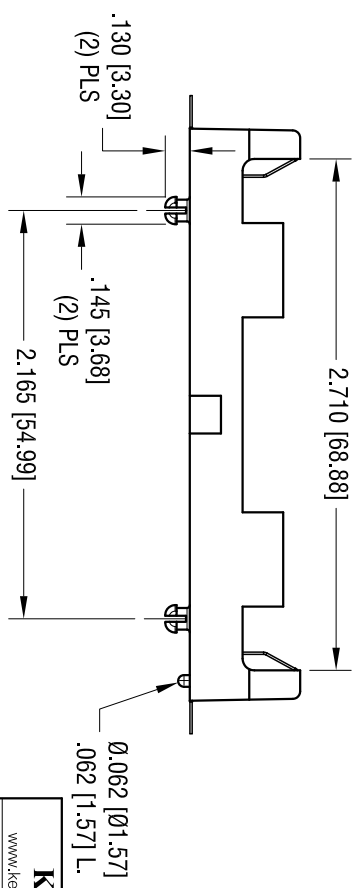
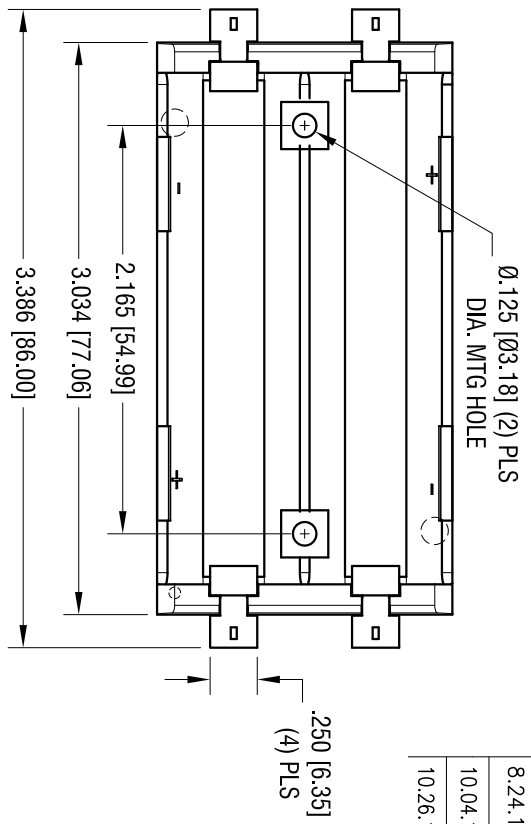
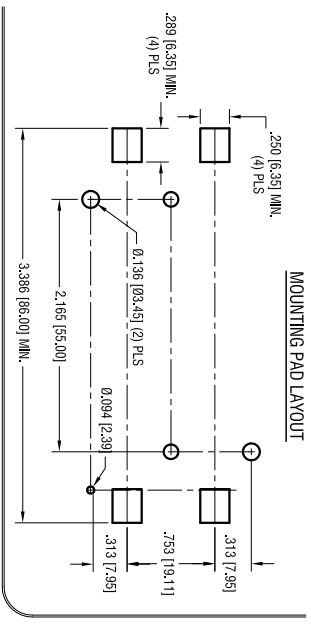

- NOTE:
1. BASE: MAT'L: HEAT RESISTANCE NYLON STANVYL 46 OR EQUIVALENT
 2. CONTACT: MAT'L: .012 [0.30] THK PHOSPHOR BRONZE FINISH: GOLD FLASH, OVER NICKEL PLATE

THIS DOCUMENT IS THE PROPERTY OF KEYSTONE ELECTRONICS CORP. AND SHALL NOT BE REPRODUCED, DISTRIBUTED OR COPIED IN ANY MANNER WITHOUT WRITTEN PERMISSION FROM KEYSTONE ELECTRONICS CORP.

KEYSTONE ELECTRONICS CORP.			
www.keystec.com • ASTORIA, N.Y. 11105-2017 • Tel (718) 956-8900			
PART NAME		DUAL SM BATTERY HOLDER , 18650	
MATERIAL		AS NOTED	
FINISH		AS NOTED	
AS NOTED	DRN BY	NT	DATE
	APPD		8.19.10
SCALE	1.25X		
TOLEBRANGES	INCH	(MM)	
DECIMAL	± .010	[± 0.25]	
ANGULAR	± 1°		
UNLESS OTHERWISE SPECIFIED		CODE	DWG NO.
		C	1048