



**This part is not recommended for new designs**  
**Use EZ-USB FX2LP instead of EZ-USB FX2 for new designs**

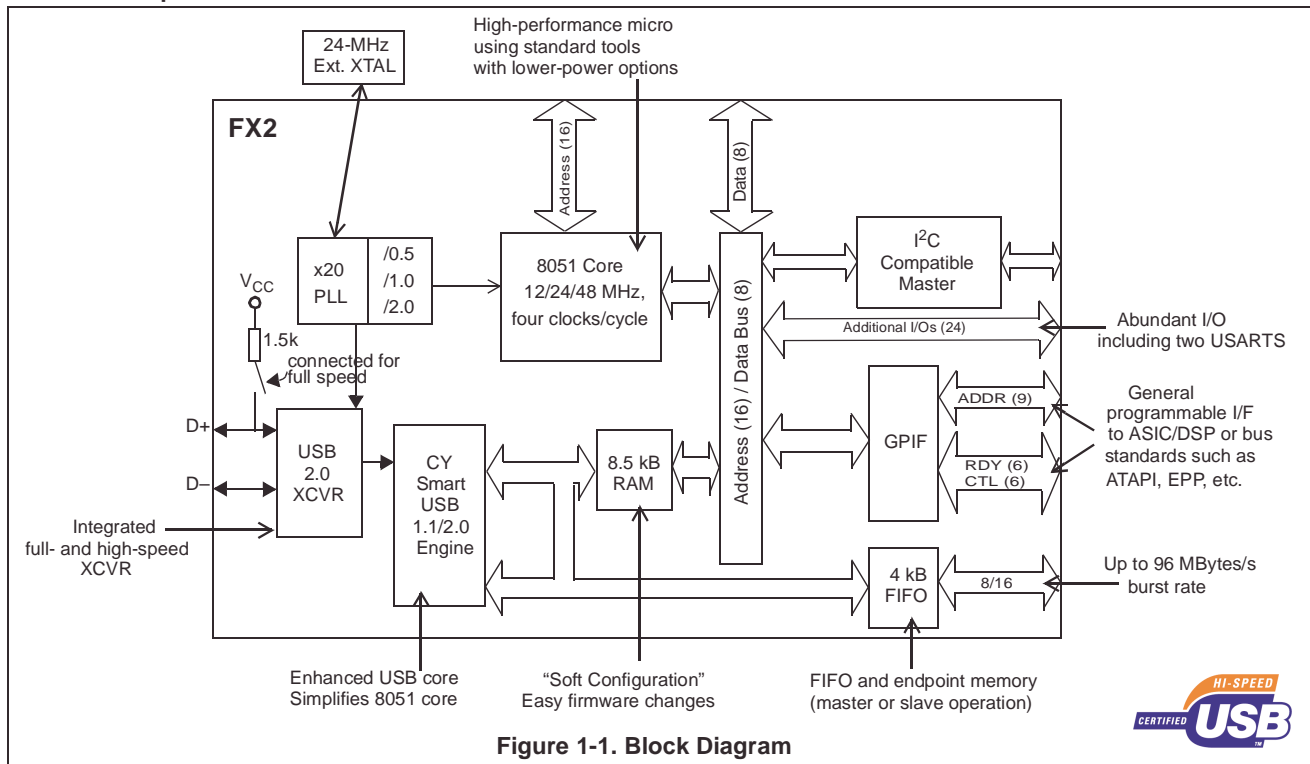
**CY7C68013**

CYPRESS

## EZ-USB FX2™ USB Microcontroller

### 1.0 EZ-USB FX2™ Features

- Single-chip integrated USB 2.0 Transceiver, SIE, and Enhanced 8051 Microprocessor
- Software: 8051 code runs from:
  - Internal RAM, which is downloaded via USB
  - Internal RAM, which is loaded from EEPROM
  - External memory device (128 pin package)
- Four programmable BULK/INTERRUPT/ISOCHRONOUS endpoints
  - Buffering options: double, triple and quad
- 8- or 16-bit external data interface
- GPIF
  - Allows direct connection to most parallel interface
  - Programmable waveform descriptors and configuration registers to define waveforms
  - Supports multiple Ready (RDY) inputs and Control (CTL) outputs
- Integrated, industry standard enhanced 8051:
  - Up to 48-MHz clock rate
  - Four clocks per instruction cycle
  - Two USARTS
  - Three counter/timers
  - Expanded interrupt system
  - Two data pointers
- Supports bus-powered applications by using reenumeration
- 3.3V operation
- Smart Serial Interface Engine
- Vectored USB interrupts
- Separate data buffers for the SETUP and DATA portions of a CONTROL transfer
- Integrated I<sup>2</sup>C-compatible controller, runs at 100 or 400 kHz
- 48-MHz, 24-MHz, or 12-MHz 8051 operation
- Four integrated FIFOs
  - Brings glue and FIFOs inside for lower system cost
  - Automatic conversion to and from 16-bit buses
  - Master or slave operation
  - FIFOs can use externally supplied clock or asynchronous strobes
  - Easy interface to ASIC and DSP ICs
- Special autovectors for FIFO and GPIF interrupts
- Up to 40 general-purpose I/Os
- Four package options—128-pin TQFP, 100-pin TQFP, 56-pin QFN and 56-pin SSOP
- Four packages are defined for the family: 56 SSOP, 56 QFN, 100 TQFP, and 128 TQFP



**Figure 1-1. Block Diagram**

Cypress's EZ-USB FX2™ is the world's first USB 2.0 integrated microcontroller. By integrating the USB 2.0 transceiver, SIE, enhanced 8051 microcontroller, and a programmable peripheral interface in a single chip, Cypress has created a very cost-effective solution that provides superior time-to-market advantages. The ingenious architecture of FX2 results in data transfer rates of 56 Mbytes per second, the maximum allowable USB 2.0 bandwidth, while still using a low-cost 8051 microcontroller in a package as small as a 56 SSOP. Because it incorporates the USB 2.0 transceiver, the FX2 is more economical, providing a smaller footprint solution than USB 2.0 SIE or external transceiver implementations. With EZ-USB FX2, the Cypress Smart SIE handles most of the USB 1.1 and 2.0 protocol in hardware, freeing the embedded microcontroller for application-specific functions and decreasing development time to ensure USB compatibility. The General Programmable Interface (GPIF) and Master/Slave Endpoint FIFO (8- or 16-bit data bus) provides an easy and glueless interface to popular interfaces such as ATA, UTOPIA, EPP, PCMCIA, and most DSP/processors.

## 2.0 Applications

- DSL modems
- ATA interface
- Memory card readers
- Legacy conversion devices
- Cameras
- Scanners
- Home PNA
- Wireless LAN
- MP3 players
- Networking.

The "Reference Designs" section of the cypress website provides additional tools for typical USB 2.0 applications. Each reference design comes complete with firmware source and object code, schematics, and documentation. Please visit <http://www.cypress.com> for more information.

## 3.0 Functional Overview

### 3.1 USB Signaling Speed

FX2 operates at two of the three rates defined in the Universal Serial Bus Specification Revision 2.0, dated April 27, 2000:

- Full speed, with a signaling bit rate of 12 Mbps
- High speed, with a signaling bit rate of 480 Mbps

FX2 does not support the low-speed signaling mode of 1.5 Mbps.

### 3.2 8051 Microprocessor

The 8051 microprocessor embedded in the FX2 family has 256 bytes of register RAM, an expanded interrupt system, three timer/counters, and two USARTs. 8051 Clock Frequency  
FX2 has an on-chip oscillator circuit that uses an external 24-MHz ( $\pm 100$  ppm) crystal with the following characteristics:

- Parallel resonant
- Fundamental mode
- 500- $\mu$ W drive level
- 20–33 pF (5% tolerance) load capacitors.

An on-chip PLL multiplies the 24-MHz oscillator up to 480 MHz, as required by the transceiver/PHY, and internal counters divide it down for use as the 8051 clock. The default 8051 clock frequency is 12 MHz. The clock frequency of the 8051 can be changed by the 8051 through the CPUCS register, dynamically.

The CLKOUT pin, which can be tri-stated and inverted using internal control bits, outputs the 50% duty cycle 8051 clock, at the selected 8051 clock frequency—48, 24, or 12 MHz.

#### 3.2.1 USARTS

FX2 contains two standard 8051 USARTs, addressed via Special Function Register (SFR) bits. The USART interface pins are available on separate I/O pins, and are not multiplexed with port pins.

UART0 and UART1 can operate using an internal clock at 230 KBaud with no more than 1% baud rate error. 230-KBaud operation is achieved by an internally derived clock source that generates overflow pulses at the appropriate time. The internal clock adjusts for the 8051 clock rate (48, 24, 12 MHz) such that it always presents the correct frequency for 230-KBaud operation.

**Note.** 115-KBaud operation is also possible by programming the 8051 SMOD0 or SMOD1 bits to a "1" for UART0 and/or UART1, respectively.

#### 3.2.2 Special Function Registers

Certain 8051 SFR addresses are populated to provide fast access to critical FX2 functions. These SFR additions are shown in *Table 3-1*. Bold type indicates non-standard, enhanced 8051 registers.

The two SFR rows that end with "0" and "8" contain bit-addressable registers. The four I/O ports A–D use the SFR addresses used in the standard 8051 for ports 0–3, which are not implemented in FX2.

Because of the faster and more efficient SFR addressing, the FX2 I/O ports are not addressable in external RAM space (using the MOVX instruction).

**Table 3-1. Special Function Registers**

x	8x	9x	Ax	Bx	Cx	Dx	Ex	Fx
0	IOA	IOB	IOC	IOD	SCON1	PSW	ACC	B
1	SP	EXIF	INT2CLR	IOE	SBUF1			
2	DPL0	MPAGE	INT4CLR	OEA				
3	DPH0			OEB				
4	DPL1			OEC				
5	DPH1			OED				
6	DPS			OEE				
7	PCON							
8	TCON	SCON0	IE	IP	T2CON	EICON	EIE	EIP
9	TMOD	SBUF0						
A	TL0	AUTOPTRH1	EP2468STAT	EP01STAT	RCAP2L			
B	TL1	AUTOPTRL1	EP24FIFOFLGS	GPIFTRIG	RCAP2H			
C	TH0	reserved	EP68FIFOFLGS		TL2			
D	TH1	AUTOPTRH2		GPIFSGLDATH	TH2			
E	CKCON	AUTOPTRL2		GPIFSGLDATLX				
F		reserved	AUTOPTRSETUP	GPIFSGLDATLNOX				

### 3.3 I<sup>2</sup>C-compatible Bus

FX2 supports the I<sup>2</sup>C-compatible bus as a master only at 100/400 kbps. SCL and SDA pins have open-drain outputs and hysteresis inputs. These signals must be pulled up to 3.3V, even if no I<sup>2</sup>C-compatible device is connected.

### 3.4 Buses

All packages: 8- or 16-bit “FIFO” bidirectional data bus, multiplexed on I/O ports B and D. 128-pin package: adds 16-bit output-only 8051 address bus, 8-bit bidirectional data bus.

### 3.5 USB Boot Methods

During the power-up sequence, internal logic checks the I<sup>2</sup>C-compatible port for the connection of an EEPROM whose first byte is either 0xC0 or 0xC2. If found, it uses the VID/PID/DID values in the EEPROM in place of the internally stored values (0xC0), or it boot-loads the EEPROM contents into internal RAM (0xC2). If no EEPROM is detected, FX2 enumerates using internally stored descriptors. The default ID values for FX2 are VID/PID/DID (0x04B4, 0x8613, 0xxxxy).

**Table 3-2. Default ID Values for FX2**

Default VID/PID/DID		
Vendor ID	0x04B4	Cypress Semiconductor
Prod ID	0x8613	EZ-USB FX2
Device release	0xXXYY	Depends on revision (0x04 for Rev E)

**Note.** The I<sup>2</sup>C-compatible bus SCL and SDA pins must be pulled up, even if an EEPROM is not connected. Otherwise this detection method does not work properly.

### 3.6 ReNumeration™

Because the FX2’s configuration is soft, one chip can take on the identities of multiple distinct USB devices.

When first plugged into USB, the FX2 enumerates automatically and downloads firmware and USB descriptor tables over the USB cable. Next, the FX2 enumerates again, this time as a device defined by the downloaded information. This patented two-step process, called ReNumeration™, happens instantly when the device is plugged in, with no hint that the initial download step has occurred.

Two control bits in the USBCS (USB Control and Status) register control the ReNumeration process: DISCON and RENUM. To simulate a USB disconnect, the firmware sets DISCON to 1. To reconnect, the firmware clears DISCON to 0.

Before reconnecting, the firmware sets or clears the RENUM bit to indicate whether the firmware or the Default USB Device will handle device requests over endpoint zero: if RENUM = 0, the Default USB Device will handle device requests; if RENUM = 1, the firmware will.

### 3.7 Bus Powered Applications

Bus powered applications require the FX2 to enumerate in a unconfigured mode with less than 100 mA. To do this, the FX2 must enumerate in the full speed mode and then, when configured, reenumerate in high speed mode. For an example of the benefits and limitations of this reenumeration process see the application note titled “Bus Powered Enumeration with FX2”.

### 3.8 Interrupt System

#### 3.8.1 INT2 Interrupt Request and Enable Registers

FX2 implements an autovector feature for INT2 and INT4. There are 27 INT2 (USB) vectors, and 14 INT4 (FIFO/GPIF) vectors. See FX2 TRM for more details.

#### 3.8.2 USB-Interrupt Autovectors

The main USB interrupt is shared by 27 interrupt sources. To save the code and processing time that normally would be required to identify the individual USB interrupt source, the FX2 provides a second level of interrupt vectoring, called

Autovectoring. When a USB interrupt is asserted, the FX2 pushes the program counter onto its stack then jumps to address 0x0043, where it expects to find a “jump” instruction to the USB Interrupt service routine.

The FX2 jump instruction is encoded as shown in *Table 3-3*.

If Autovectoring is enabled (AV2EN = 1 in the INTSETUP register), the FX2 substitutes its INT2VEC byte. Therefore, if the high byte (“page”) of a jump-table address is preloaded at location 0x0044, the automatically-inserted INT2VEC byte at 0x0045 will direct the jump to the correct address out of the 27 addresses within the page.

**Table 3-3. INT2 USB Interrupts**

USB Interrupt Table for INT2			
Priority	INT2VEC Value	Source	Notes
1	00	SUDAV	SETUP Data Available
2	04	SOF	Start of Frame (or microframe)
3	08	SUTOK	Setup Token Received
4	0C	SUSPEND	USB Suspend request
5	10	USB RESET	Bus reset
6	14	HISPEED	Entered high-speed operation
7	18	EP0ACK	FX2 ACK'd the CONTROL Handshake
8	1C		reserved
9	20	EP0-IN	EP0-IN ready to be loaded with data
10	24	EP0-OUT	EP0-OUT has USB data
11	28	EP1-IN	EP1-IN ready to be loaded with data
12	2C	EP1-OUT	EP1-OUT has USB data
13	30	EP2	IN: buffer available. OUT: buffer has data
14	34	EP4	IN: buffer available. OUT: buffer has data
15	38	EP6	IN: buffer available. OUT: buffer has data
16	3C	EP8	IN: buffer available. OUT: buffer has data
17	40	IBN	IN-Bulk-NAK (any IN endpoint)
18	44		reserved
19	48	EP0PING	EP0 OUT was Pinged and it NAK'd
20	4C	EP1PING	EP1 OUT was Pinged and it NAK'd
21	50	EP2PING	EP2 OUT was Pinged and it NAK'd
22	54	EP4PING	EP4 OUT was Pinged and it NAK'd
23	58	EP6PING	EP6 OUT was Pinged and it NAK'd
24	5C	EP8PING	EP8 OUT was Pinged and it NAK'd
25	60	ERRLIMIT	Bus errors exceeded the programmed limit
26	64		reserved
27	68		reserved
28	6C		reserved
29	70	EP2ISOERR	ISO EP2 OUT PID sequence error
30	74	EP4ISOERR	ISO EP4 OUT PID sequence error
31	78	EP6ISOERR	ISO EP6 OUT PID sequence error
32	7C	EP8ISOERR	ISO EP8 OUT PID sequence error

**Table 3-4. Individual FIFO/GPIF Interrupt Sources**

Priority	INT4VEC Value	Source	Notes
1	80	EP2PF	Endpoint 2 Programmable Flag
2	84	EP4PF	Endpoint 4 Programmable Flag
3	88	EP6PF	Endpoint 6 Programmable Flag
4	8C	EP8PF	Endpoint 8 Programmable Flag
5	90	EP2EF	Endpoint 2 Empty Flag
6	94	EP4EF	Endpoint 4 Empty Flag
7	98	EP6EF	Endpoint 6 Empty Flag
8	9C	EP8EF	Endpoint 8 Empty Flag
9	A0	EP2FF	Endpoint 2 Full Flag
10	A4	EP4FF	Endpoint 4 Full Flag
11	A8	EP6FF	Endpoint 6 Full Flag
12	AC	EP8FF	Endpoint 8 Full Flag
13	B0	GPIFDONE	GPIF Operation Complete
14	B4	GPIFWF	GPIF Waveform

### 3.8.3 FIFO/GPIF Interrupt (INT4)

Just as the USB Interrupt is shared among 27 individual USB-interrupt sources, the FIFO/GPIF interrupt is shared among 14 individual FIFO/GPIF sources. The FIFO/GPIF Interrupt, like the USB Interrupt, can employ autovectoring. *Table 3-4* shows the priority and INT4VEC values for the 14 FIFO/GPIF interrupt sources.

If Autovectoring is enabled (AV4EN = 1 in the INTSETUP register), the FX2 substitutes its INT4VEC byte. Therefore, if the high byte (“page”) of a jump-table address is preloaded at location 0x0054, the automatically-inserted INT4VEC byte at 0x0055 will direct the jump to the correct address out of the 14 addresses within the page. When the ISR occurs, the FX2 pushes the program counter onto its stack then jumps to address 0x0053, where it expects to find a “jump” instruction to the ISR Interrupt service routine.

## 3.9 Reset and Wakeup

### 3.9.1 Reset Pin

An input pin (RESET#) resets the chip. This pin has hysteresis and is active LOW. The internal PLL stabilizes approximately 200  $\mu$ s after  $V_{CC}$  has reached 3.3V. Typically, an external RC network (R = 100k, C = 0.1  $\mu$ F) is used to provide the RESET# signal.

### 3.9.2 Wakeup Pins

The 8051 puts itself and the rest of the chip into a power-down mode by setting PCON.0 = 1. This stops the oscillator and PLL. When WAKEUP is asserted by external logic, the oscillator restarts and after the PLL stabilizes, and the 8051 receives a wakeup interrupt. This applies whether or not FX2 is connected to the USB.

The FX2 exits the power down (USB suspend) state using one of the following methods:

- USB bus signals resume
- External logic asserts the WAKEUP pin
- External logic asserts the PA3/WU2 pin.

The second wakeup pin, WU2, can also be configured as a general purpose I/O pin. This allows a simple external R-C network to be used as a periodic wakeup source.

## 3.10 Program/Data RAM

### 3.10.1 Size

The FX2 has eight kbytes of internal program/data RAM, where PSEN#/RD# signals are internally ORed to allow the 8051 to access it as both program and data memory. No USB control registers appear in this space.

Two memory maps are shown in the following diagrams:

*Figure 3-1* Internal Code Memory, EA = 0

*Figure 3-2* External Code Memory, EA = 1.

### 3.10.2 Internal Code Memory, EA = 0

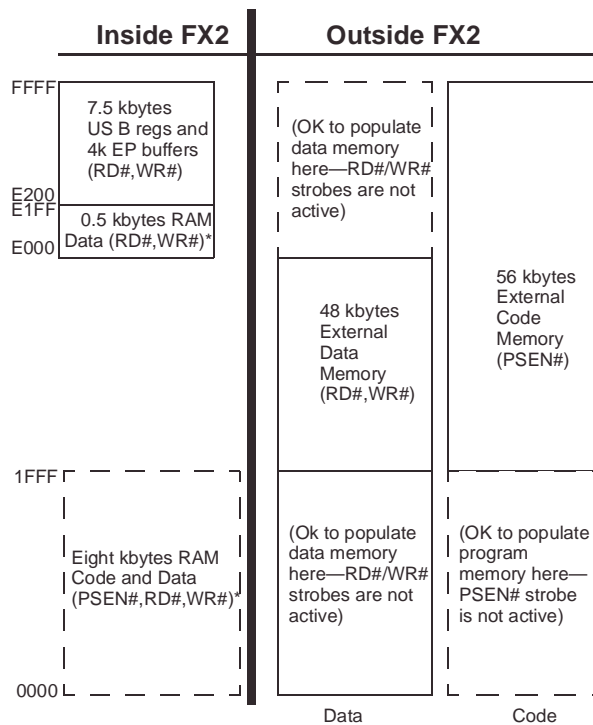
This mode implements the internal eight-kbyte block of RAM (starting at 0) as combined code and data memory. When external RAM or ROM is added, the external read and write strobes are suppressed for memory spaces that exist inside the chip. This allows the user to connect a 64-kbyte memory without requiring address decodes to keep clear of internal memory spaces.

Only the **internal** eight kbytes and **scratch pad** 0.5 kbytes RAM spaces have the following access:

- USB download
- USB upload
- Setup data pointer
- I<sup>2</sup>C-compatible interface boot load.

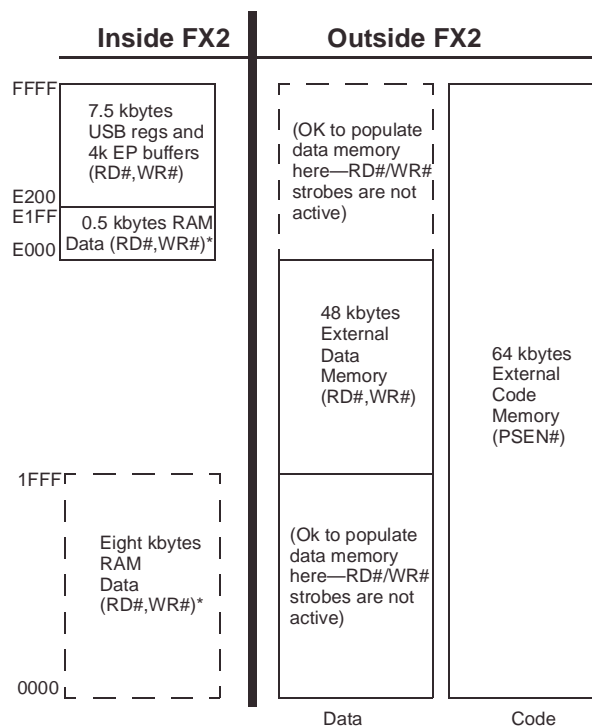
### 3.10.3 External Code Memory, EA = 1

The bottom eight kbytes of program memory is external, and therefore the bottom eight kbytes of internal RAM is accessible only as data memory.



\*SUDPTR, USB upload/download, I<sup>2</sup>C-compatible interface boot access

**Figure 3-1. Internal Code Memory, EA = 0**



\*SUDPTR, USB upload/download, I<sup>2</sup>C-compatible interface boot access

**Figure 3-2. External Code Memory, EA = 1**



### 3.11 Register Addresses

FFFF	4 kbytes EP2-EP8 buffers (8 × 512)
F000 EFFF	
E800 E7FF	2 kbytes RESERVED
E7C0 E7BF	64 bytes EP1IN
E780 E77F	64 bytes EP1OUT
E740 E73F	64 bytes EP0 IN/OUT
E700 E6FF	64 bytes RESERVED
E600 E5FF	256 bytes Registers
E480 E47F	384 bytes RESERVED
E400 E3FF	128 bytes GPIF Waveforms
E200 E1FF	512 bytes RESERVED
E000	512 bytes 8051 xdata RAM

### 3.12 Endpoint RAM

#### 3.12.1 Size

- 3 × 64 bytes (Endpoints 0 and 1)
- 8 × 512 bytes (Endpoints 2, 4, 6, 8)

#### 3.12.2 Organization

- EP0

Bidirectional endpoint zero, 64-byte buffer

- EP1IN, EP1OUT

64-byte buffers, bulk or interrupt

- EP2,4,6,8

Eight 512-byte buffers, bulk, interrupt, or isochronous. EP2 and 6 can be either double, triple, or quad buffered. For high-speed endpoint configuration options, see *Figure 3-3*.

#### 3.12.3 Set-up Data Buffer

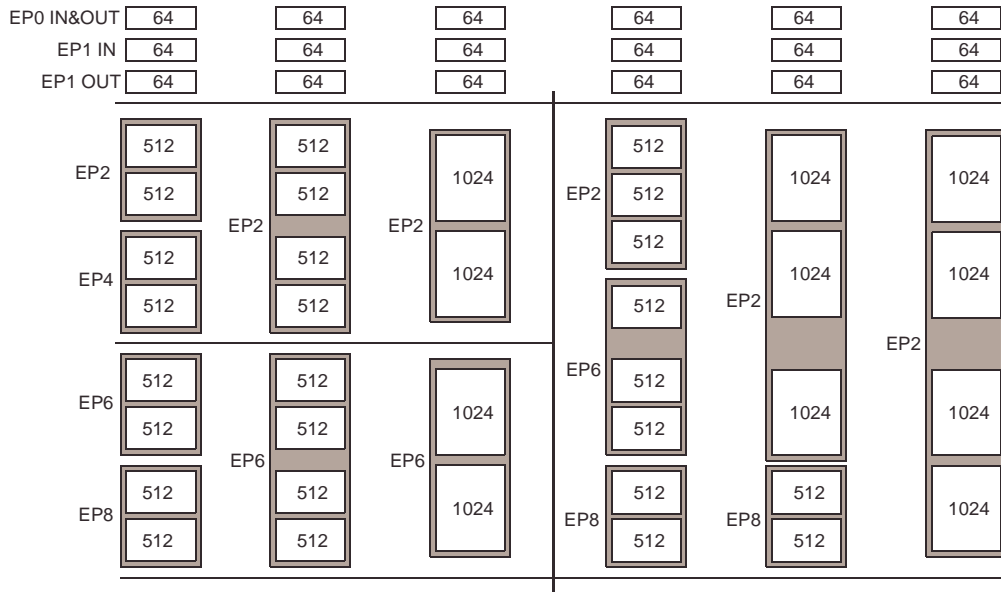
A separate eight-byte buffer at 0xE6B8-0xE6BF holds the SETUP data from a CONTROL transfer.

#### 3.12.4 Endpoint Configuration (High-speed Mode)

Endpoints 0 and 1 are the same for every configuration. Endpoint 0 is the only CONTROL endpoint, and endpoint 1 can be either BULK or INTERRUPT. To the left of the vertical line, the user may pick different configurations for EP2&4 and EP6&8, since none of the 512-byte buffers are combined between these endpoint groups. An example endpoint configuration would be:

EP2—1024 double buffered; EP6—512 quad buffered.

To the right of the vertical line, buffers are shared between EP2–8, and therefore only entire columns may be chosen.


**Figure 3-3. Endpoint Configuration**
**3.12.5 Default Full-Speed Alternate Settings**
**Table 3-5. Default Full-Speed Alternate Settings<sup>[1,2]</sup>**

Alternate Setting	0	1	2	3
ep0	64	64	64	64
ep1out	0	64 bulk	64 int	64 int
ep1in	0	64 bulk	64 int	64 int
ep2	0	64 bulk out (2x)	64 int out (2x)	64 iso out (2x)
ep4	0	64 bulk out (2x)	64 bulk out (2x)	64 bulk out (2x)
ep6	0	64 bulk in (2x)	64 int in (2x)	64 iso in (2x)
ep8	0	64 bulk in (2x)	64 bulk in (2x)	64 bulk in (2x)

**3.12.6 Default High-Speed Alternate Settings**
**Table 3-6. Default High-Speed Alternate Settings<sup>[1, 2]</sup>**

Alternate Setting	0	1	2	3
ep0	64	64	64	64
ep1out	0	512 bulk <sup>[3]</sup>	64 int	64 int
ep1in	0	512 bulk <sup>[3]</sup>	64 int	64 int
ep2	0	512 bulk out (2x)	512 int out (2x)	512 iso out (2x)
ep4	0	512 bulk out (2x)	512 bulk out (2x)	512 bulk out (2x)
ep6	0	512 bulk in (2x)	512 int in (2x)	512 iso in (2x)
ep8	0	512 bulk in (2x)	512 bulk in (2x)	512 bulk in (2x)

**Notes:**

1. "0" means "not implemented."
2. "2x" means "double buffered."
3. Even though these buffers are 64 bytes, they are reported as 512 for USB 2.0 compliance. The user must never transfer packets larger than 64 bytes to EP1.



### 3.13 External FIFO interface

#### 3.13.1 Architecture

The FX2 slave FIFO architecture has eight 512-byte blocks in the endpoint RAM that directly serve as FIFO memories, and are controlled by FIFO control signals (such as IFCLK, SLCS#, SLRD, SLWR, SLOE, PKTEND, and flags).

In operation, some of the eight RAM blocks fill or empty from the SIE, while the others are connected to the I/O transfer logic. The transfer logic takes two forms, the GPIF for internally generated control signals, or the slave FIFO interface for externally controlled transfers.

#### 3.13.2 Master/Slave Control Signals

The FX2 endpoint FIFOS are implemented as eight physically distinct 256 x 16 RAM blocks. The 8051/SIE can switch any of the RAM blocks between two domains, the USB (SIE) domain and the 8051-I/O Unit domain. This switching is done virtually instantaneously, giving essentially zero transfer time between “USB FIFOS” and “Slave FIFOS.” Since they are physically the same memory, no bytes are actually transferred between buffers.

At any given time, some RAM blocks are filling/emptying with USB data under SIE control, while other RAM blocks are available to the 8051 and/or the I/O control unit. The RAM blocks operate as single-port in the USB domain, and dual-port in the 8051-I/O domain. The blocks can be configured as single, double, triple, or quad buffered as previously shown.

The I/O control unit implements either an internal-master (M for master) or external-master (S for Slave) interface.

In Master (M) mode, the GPIF internally controls FIFOADR[1..0] to select a FIFO. The RDY pins (two in the 56-pin package, six in the 100-pin and 128-pin packages) can be used as flag inputs from an external FIFO or other logic if desired. The GPIF can be run from either an internally derived clock or externally supplied clock (IFCLK), at a rate that transfers data up to 96 Megabytes/s (48 MHz).

In Slave (S) mode, the FX2 accepts either an internally derived clock or externally supplied clock (IFCLK, max. frequency 48 MHz) and SLCS#, SLRD, SLWR, SLOE, PKTEND signals from external logic. Each endpoint can individually be selected for byte or word operation by an internal configuration bit, and a Slave FIFO Output Enable signal SLOE enables data of the selected width. External logic must insure that the output enable signal is inactive when writing data to a slave FIFO. The slave interface can also operate asynchronously, where the SLRD and SLWR signals act directly as strobes, rather than a clock qualifier as in synchronous mode. The signals SLRD, SLWR, SLOE and PKTEND are gated by the signal SLCS#.

#### 3.13.3 GPIF and FIFO Clock Rates

An 8051 register bit selects one of two frequencies for the internally supplied interface clock: 30 MHz and 48 MHz. Alternatively, an externally supplied clock of 5 MHz–48 MHz feeding the IFCLK pin can be used as the interface clock. IFCLK can be configured to function as an output clock when the GPIF and FIFOS are internally clocked. An output enable bit in the IFCONFIG register turns this clock output off, if

desired. Another bit within the IFCONFIG register will invert the IFCLK signal whether internally or externally sourced.

#### 3.14 GPIF

The GPIF is a flexible 8- or 16-bit parallel interface driven by a user-programmable finite state machine. It allows the CY7C68013 to perform local bus mastering, and can implement a wide variety of protocols such as ATA interface, printer parallel port, and Utopia.

The GPIF has six programmable control outputs (CTL), nine address outputs (GPIFADR<sub>x</sub>), and six general-purpose ready inputs (RDY). The data bus width can be 8 or 16 bits. Each GPIF vector defines the state of the control outputs, and determines what state a ready input (or multiple inputs) must be before proceeding. The GPIF vector can be programmed to advance a FIFO to the next data value, advance an address, etc. A sequence of the GPIF vectors make up a single waveform that will be executed to perform the desired data move between the CY7C68013 and the external design.

##### 3.14.1 Six Control OUT Signals

The 100- and 128-pin packages bring out all six Control Output pins (CTL0–CTL5). The 8051 programs the GPIF unit to define the CTL waveforms. The 56-pin package brings out three of these signals, CTL0–CTL2. CTL<sub>x</sub> waveform edges can be programmed to make transitions as fast as once per clock (20.8 ns using a 48-MHz clock).

##### 3.14.2 Six Ready IN Signals

The 100- and 128-pin packages bring out all six Ready inputs (RDY0–RDY5). The 8051 programs the GPIF unit to test the RDY pins for GPIF branching. The 56-pin package brings out two of these signals, RDY0–1.

##### 3.14.3 Nine GPIF Address OUT signals

Nine GPIF address lines are available in the 100- and 128-pin packages, GPIFADR[8..0]. The GPIF address lines allow indexing through up to a 512-byte block of RAM. If more address lines are needed, I/O port pins can be used.

##### 3.14.4 Long Transfer Mode

In master mode, the 8051 appropriately sets GPIF transaction count registers (GPIFTCB3, GPIFTCB2, GPIFTCB1, or GPIFTCB0) for unattended transfers of up to 4,294,967,296 bytes. The GPIF automatically throttles data flow to prevent under or overflow until the full number of requested transactions complete. The GPIF decrements the value in these registers to represent the current status of the transaction.

### 3.15 USB Uploads and Downloads

The core has the ability to directly edit the data contents of the internal 8-kbyte RAM and of the internal 512-byte scratch pad RAM via a vendor-specific command. This capability is normally used when “soft” downloading user code and is available only to and from internal RAM, whether the 8051 is held in reset or running. The available RAM spaces are 8 kbytes from 0x0000–0x1FFF (code/data) and 512 bytes from 0xE000–0xE1FF (scratch pad RAM).

**Note:** A “loader” running in internal RAM can be used to transfer downloaded data to external memory.

### 3.16 Autopointer Access

FX2 provides two identical autopointers. They are similar to the internal 8051 data pointers, but with an additional feature: they can optionally increment a pointer address after every memory access. This capability is available to and from both internal and external RAM. The autopointers are available in external FX2 registers, under control of a mode bit (AUTOP-TRSETUP.0). Using the external FX2 autopointer access (at 0xE67B – 0xE67C) allows the autopointer to access all RAM, internal and external to the part. Also, the autopointers can point to any FX2 register or endpoint buffer space. When autopointer access to external memory is enabled, location 0xE67B and 0xE67C in XDATA and PDATA space cannot be used.

### 3.17 I<sup>2</sup>C-compatible Controller

FX2 has one I<sup>2</sup>C-compatible port that is driven by two internal controllers, one that automatically operates at boot time to load VID/PID/DID and configuration information, and another that the 8051, once running, uses to control external I<sup>2</sup>C-compatible devices. The I<sup>2</sup>C-compatible port operates in master mode only.

#### 3.17.1 I<sup>2</sup>C-compatible Port Pins

The I<sup>2</sup>C-compatible pins SCL and SDA must have external 2.2-kΩ pull-up resistors. External EEPROM device address pins must be configured properly. See *Table 3-7* for configuring the device address pins.

**Table 3-7. Strap Boot EEPROM Address Lines to These Values**

Bytes	Example EEPROM	A2	A1	A0
16	24LC00 <sup>[4]</sup>	N/A	N/A	N/A
128	24LC01	0	0	0
256	24LC02	0	0	0
4K	24LC32	0	0	1
8K	24LC64	0	0	1

**Note:**

4. This EEPROM does not have address pins.

#### 3.17.2 I<sup>2</sup>C-compatible Interface Boot Load Access

At power-on reset the I<sup>2</sup>C-compatible interface boot loader will load the VID/PID/DID/a configuration byte and up to eight kbytes of program/data. The available RAM spaces are eight kbytes from 0x0000–0x1FFF and 512 bytes from 0xE000–0xE1FF. The 8051 will be in reset. I<sup>2</sup>C-compatible interface boot loads only occur after power-on reset.

#### 3.17.3 I<sup>2</sup>C-compatible Interface General Purpose Access

The 8051 can control peripherals connected to the I<sup>2</sup>C-compatible bus using the I2CTL and I2DAT registers. FX2 provides I<sup>2</sup>C compatible master control only, it is never an I<sup>2</sup>C-compatible slave.

## 4.0 Pin Assignments

*Figure 4-1* identifies all signals for the four package types. The following pages illustrate the individual pin diagrams, plus a combination diagram showing which of the full set of signals are available in the 128-, 100-, and 56-pin packages.

The 56-pin package is the lowest-cost version. The signals on the left edge of the 56-pin package in *Figure 4-1* are common to all versions in the FX2 family. Three modes are available in all package versions: Port, GPIF master, and Slave FIFO. These modes define the signals on the right edge of the diagram. The 8051 selects the interface mode using the IFCONFIG[1:0] register bits. Port mode is the power-on default configuration.

The 100-pin package adds functionality to the 56-pin package by adding these pins:

- PORTC or alternate GPIFADR[7...0] address signals
- PORTE or alternate GPIFADR8 address signals and 7 more 8051 signals
- Three GPIF Control signals
- Four GPIF Ready signals
- Nine 8051 signals (two USARTs, three timer inputs, INT4, and INT5#)
- BKPT, RD#, WR#

The 128-pin package is the full version, adding the 8051 address and data buses plus control signals. Note that two of the required signals, RD# and WR#, are present in the 100-pin version. In the 100-pin and 128-pin versions, an 8051 control bit can be set to pulse the RD# and WR# pins when the 8051 reads from/writes to PORTC.



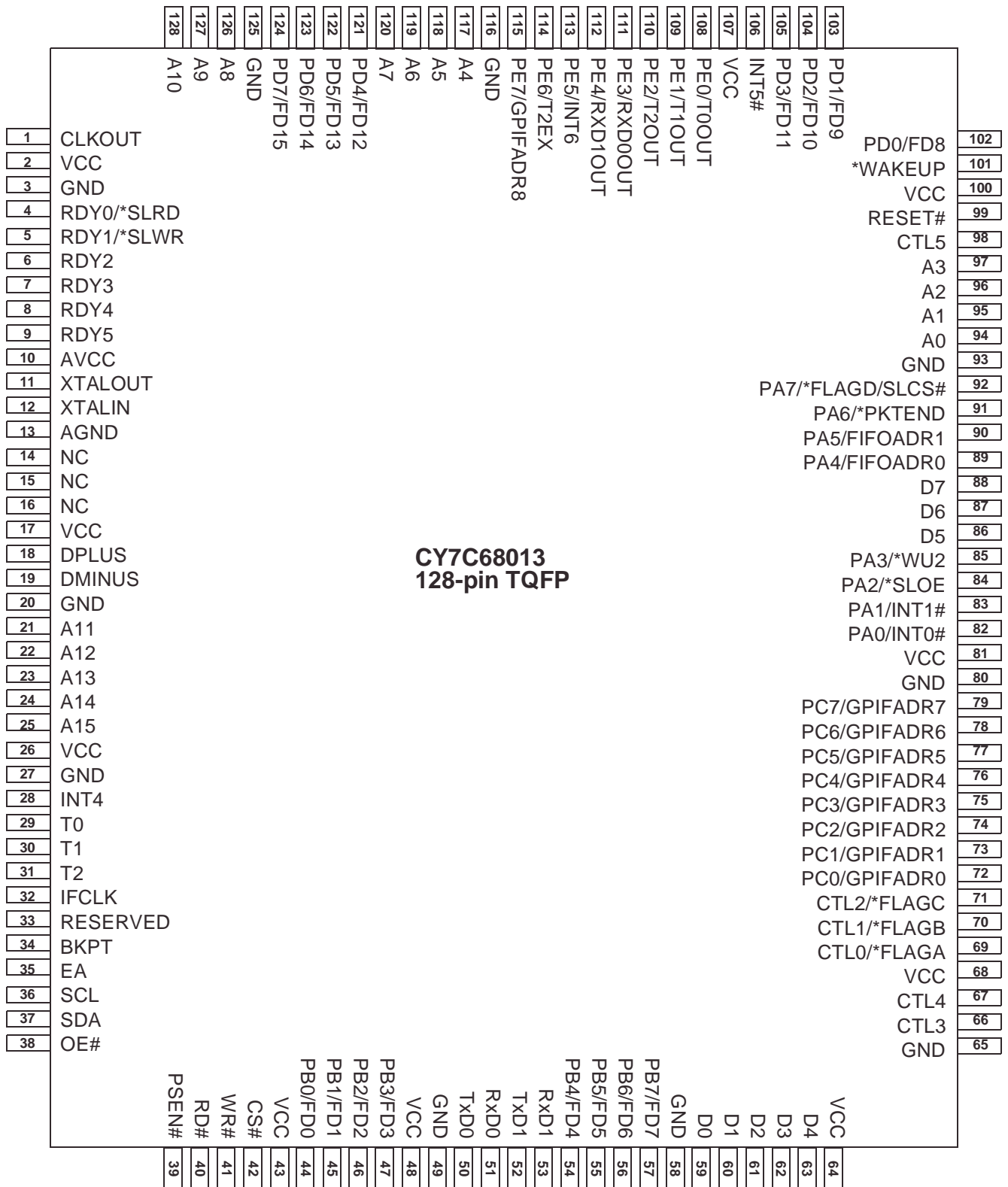


Figure 4-2. CY7C68013 128-pin TQFP Pin Assignment

\* denotes programmable polarity

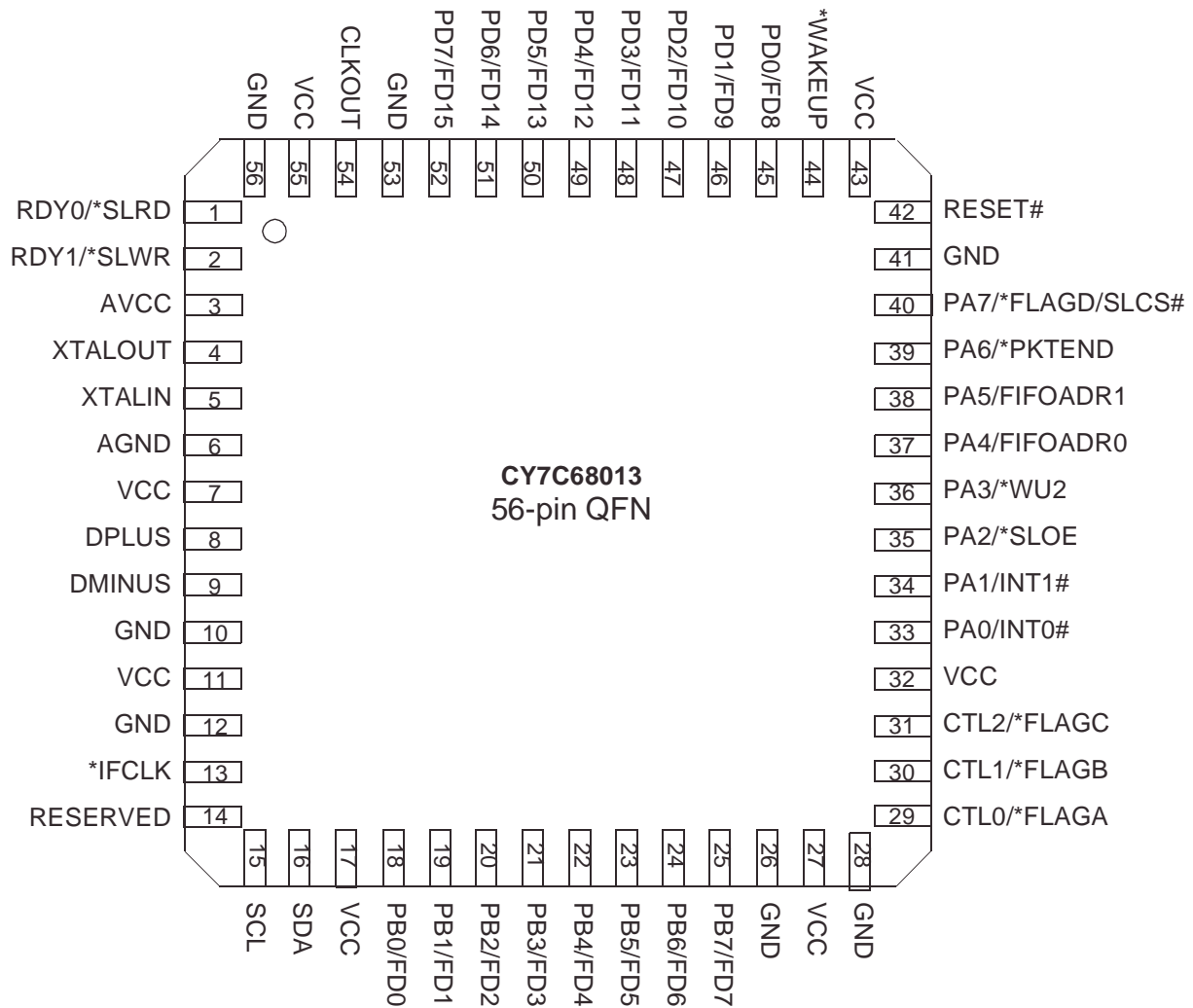


**CY7C68013  
56-pin SSOP**

1	PD5/FD13	PD4/FD12	56
2	PD6/FD14	PD3/FD11	55
3	PD7/FD15	PD2/FD10	54
4	GND	PD1/FD9	53
5	CLKOUT	PD0/FD8	52
6	VCC	*WAKEUP	51
7	GND	VCC	50
8	$\overline{\text{RDY0}}$ /*SLRD	RESET#	49
9	RDY1/*SLWR	GND	48
10	AVCC	PA7/*FLAGD/SLCS#	47
11	XTALOUT	PA6/PKTEND	46
12	XTALIN	PA5/FIFOADR1	45
13	AGND	PA4/FIFOADR0	44
14	VCC	PA3/*WU2	43
15	DPLUS	PA2/*SLOE	42
16	DMINUS	PA1/INT1#	41
17	GND	PA0/INT0#	40
18	VCC	VCC	39
19	GND	CTL2/*FLAGC	38
20	IFCLK	CTL1/*FLAGB	37
21	RESERVED	CTL0/*FLAGA	36
22	SCL	GND	35
23	SDA	VCC	34
24	VCC	GND	33
25	PB0/FD0	PB7/FD7	32
26	PB1/FD1	PB6/FD6	31
27	PB2/FD2	PB5/FD5	30
28	PB3/FD3	PB4/FD4	29

**Figure 4-4. CY7C68013 56-pin SSOP Pin Assignment**

\* denotes programmable polarity



**Figure 4-5. CY7C68013 56-pin QFN Pin Assignment**

\* denotes programmable polarity



**4.1 CY7C68013 Pin Descriptions**
**Table 4-1. FX2 Pin Descriptions** <sup>[5]</sup>

128 TQFP	100 TQFP	56 SSOP	56 QFN	Name	Type	Default	Description
10	9	10	3	AVCC	Power	N/A	<b>Analog V<sub>CC</sub></b> . This signal provides power to the analog section of the chip.
13	12	13	6	AGND	Power	N/A	<b>Analog Ground</b> . Connect to ground with as short a path as possible.
19	18	16	9	DMINUS	I/O/Z	Z	<b>USB D<sup>-</sup> Signal</b> . Connect to the USB D <sup>-</sup> signal.
18	17	15	8	DPLUS	I/O/Z	Z	<b>USB D<sup>+</sup> Signal</b> . Connect to the USB D <sup>+</sup> signal.
94				A0	Output	L	<b>8051 Address Bus</b> . This bus is driven at all times. When the 8051 is addressing internal RAM it reflects the internal address.
95				A1	Output	L	
96				A2	Output	L	
97				A3	Output	L	
117				A4	Output	L	
118				A5	Output	L	
119				A6	Output	L	
120				A7	Output	L	
126				A8	Output	L	
127				A9	Output	L	
128				A10	Output	L	
21				A11	Output	L	
22				A12	Output	L	
23				A13	Output	L	
24				A14	Output	L	
25				A15	Output	L	
59				D0	I/O/Z	Z	<b>8051 Data Bus</b> . This bidirectional bus is high-impedance when inactive, input for bus reads, and output for bus writes. The data bus is used for external 8051 program and data memory. The data bus is active only for external bus accesses, and is driven LOW in suspend.
60				D1	I/O/Z	Z	
61				D2	I/O/Z	Z	
62				D3	I/O/Z	Z	
63				D4	I/O/Z	Z	
86				D5	I/O/Z	Z	
87				D6	I/O/Z	Z	
88				D7	I/O/Z	Z	
39				PSEN#	Output	H	<b>Program Store Enable</b> . This active-LOW signal indicates an 8051 code fetch from external memory. It is active for program memory fetches from 0x2000–0xFFFF when the EA pin is LOW, or from 0x0000–0xFFFF when the EA pin is HIGH.
34	28			BKPT	Output	L	<b>Breakpoint</b> . This pin goes active (HIGH) when the 8051 address bus matches the BPADDRH/L registers and breakpoints are enabled in the BREAKPT register (BPEN = 1). If the BPPULSE bit in the BREAKPT register is HIGH, this signal pulses HIGH for eight 12-/24-/48-MHz clocks. If the BPPULSE bit is LOW, the signal remains HIGH until the 8051 clears the BREAK bit (by writing 1 to it) in the BREAKPT register.
99	77	49	42	RESET#	Input	N/A	<b>Active LOW Reset</b> . Resets the entire chip. This pin is normally tied to V <sub>CC</sub> through a 100K resistor, and to GND through a 0.1-μF capacitor.

**Note:**

5. Unused inputs should not be left floating. Tie either HIGH or LOW as appropriate. Outputs should only be pulled up or down to ensure signals at power-up and in standby.

**Table 4-1. FX2 Pin Descriptions** (continued)<sup>[5]</sup>

128 TQFP	100 TQFP	56 SSOP	56 QFN	Name	Type	Default	Description
35				EA	Input	N/A	<b>External Access.</b> This pin determines where the 8051 fetches code between addresses 0x0000 and 0x1FFF. If EA = 0 the 8051 fetches this code from its internal RAM. If EA = 1 the 8051 fetches this code from external memory.
12	11	12	5	XTALIN	Input	N/A	<b>Crystal Input.</b> Connect this signal to a 24-MHz parallel-resonant, fundamental mode crystal and load capacitor to GND. It is also correct to drive XTALIN with an external 24 MHz square wave derived from another clock source.
11	10	11	4	XTALOUT	Output	N/A	<b>Crystal Output.</b> Connect this signal to a 24-MHz parallel-resonant, fundamental mode crystal and load capacitor to GND. If an external clock is used to drive XTALIN, leave this pin open.
1	100	5	54	CLKOUT	O/Z	12 MHz	12-, 24- or 48-MHz clock, phase locked to the 24-MHz input clock. The 8051 defaults to 12-MHz operation. The 8051 may tri-state this output by setting CPUCS.1 = 1.
<b>Port A</b>							
82	67	40	33	PA0 or INT0#	I/O/Z	I (PA0)	Multiplexed pin whose function is selected by: PORTACFG.0 <b>PA0</b> is a bidirectional IO port pin. <b>INT0#</b> is the active-LOW 8051 INT0 interrupt input signal, which is either edge triggered (IT0 = 1) or level triggered (IT0 = 0).
83	68	41	34	PA1 or INT1#	I/O/Z	I (PA1)	Multiplexed pin whose function is selected by: PORTACFG.1 <b>PA1</b> is a bidirectional IO port pin. <b>INT1#</b> is the active-LOW 8051 INT1 interrupt input signal, which is either edge triggered (IT1 = 1) or level triggered (IT1 = 0).
84	69	42	35	PA2 or SLOE	I/O/Z	I (PA2)	Multiplexed pin whose function is selected by two bits: IFCONFIG[1:0]. <b>PA2</b> is a bidirectional IO port pin. <b>SLOE</b> is an input-only output enable with programmable polarity (FIFOPOLAR.4) for the slave FIFOs connected to FD[7..0] or FD[15..0].
85	70	43	36	PA3 or WU2	I/O/Z	I (PA3)	Multiplexed pin whose function is selected by: WAKEUP.7 and OEA.3 <b>PA3</b> is a bidirectional I/O port pin. <b>WU2</b> is an alternate source for <b>USB Wakeup</b> , enabled by WU2EN bit (WAKEUP.1) and polarity set by WU2POL (WAKEUP.4). If the 8051 is in suspend and WU2EN = 1, a transition on this pin starts up the oscillator and interrupts the 8051 to allow it to exit the suspend mode. Asserting this pin inhibits the chip from suspending, if WU2EN=1.
89	71	44	37	PA4 or FIFOADR0	I/O/Z	I (PA4)	Multiplexed pin whose function is selected by: IFCONFIG[1..0]. <b>PA4</b> is a bidirectional I/O port pin. <b>FIFOADR0</b> is an input-only address select for the slave FIFOs connected to FD[7..0] or FD[15..0].
90	72	45	38	PA5 or FIFOADR1	I/O/Z	I (PA5)	Multiplexed pin whose function is selected by: IFCONFIG[1..0]. <b>PA5</b> is a bidirectional I/O port pin. <b>FIFOADR1</b> is an input-only address select for the slave FIFOs connected to FD[7..0] or FD[15..0].
91	73	46	39	PA6 or PKTEND	I/O/Z	I (PA6)	Multiplexed pin whose function is selected by the IFCONFIG[1:0] bits. <b>PA6</b> is a bidirectional I/O port pin. <b>PKTEND</b> is an input-only packet end with programmable polarity (FIFOPOLAR.5) for the slave FIFOs connected to FD[7..0] or FD[15..0].

**Table 4-1. FX2 Pin Descriptions** (continued)<sup>[5]</sup>

128 TQFP	100 TQFP	56 SSOP	56 QFN	Name	Type	Default	Description
92	74	47	40	PA7 or FLAGD or SLCS#	I/O/Z	I (PA7)	Multiplexed pin whose function is selected by the IFCONFIG[1:0] and PORTACFG.7 bits. <b>PA7</b> is a bidirectional I/O port pin. <b>FLAGD</b> is a programmable slave-FIFO output status flag signal. <b>SLCS#</b> gates all other slave FIFO enable/strobes
<b>Port B</b>							
44	34	25	18	PB0 or FD[0]	I/O/Z	I (PB0)	Multiplexed pin whose function is selected by the following bits: IFCONFIG[1..0]. <b>PB0</b> is a bidirectional I/O port pin. <b>FD[0]</b> is the bidirectional FIFO/GPIF data bus.
45	35	26	19	PB1 or FD[1]	I/O/Z	I (PB1)	Multiplexed pin whose function is selected by the following bits: IFCONFIG[1..0]. <b>PB1</b> is a bidirectional I/O port pin. <b>FD[1]</b> is the bidirectional FIFO/GPIF data bus.
46	36	27	20	PB2 or FD[2]	I/O/Z	I (PB2)	Multiplexed pin whose function is selected by the following bits: IFCONFIG[1..0]. <b>PB2</b> is a bidirectional I/O port pin. <b>FD[2]</b> is the bidirectional FIFO/GPIF data bus.
47	37	28	21	PB3 or TXD1 or FD[3]	I/O/Z	I (PB3)	Multiplexed pin whose function is selected by the following bits: IFCONFIG[1..0]. <b>PB3</b> is a bidirectional I/O port pin. <b>FD[3]</b> is the bidirectional FIFO/GPIF data bus.
54	44	29	22	PB4 or FD[4]	I/O/Z	I (PB4)	Multiplexed pin whose function is selected by the following bits: IFCONFIG[1..0]. <b>PB4</b> is a bidirectional I/O port pin. <b>FD[4]</b> is the bidirectional FIFO/GPIF data bus.
55	45	30	23	PB5 or FD[5]	I/O/Z	I (PB5)	Multiplexed pin whose function is selected by the following bits: IFCONFIG[1..0]. <b>PB5</b> is a bidirectional I/O port pin. <b>FD[5]</b> is the bidirectional FIFO/GPIF data bus.
56	46	31	24	PB6 or FD[6]	I/O/Z	I (PB6)	Multiplexed pin whose function is selected by the following bits: IFCONFIG[1..0]. <b>PB6</b> is a bidirectional I/O port pin. <b>FD[6]</b> is the bidirectional FIFO/GPIF data bus.
57	47	32	25	PB7 or FD[7]	I/O/Z	I (PB7)	Multiplexed pin whose function is selected by the following bits: IFCONFIG[1..0]. <b>PB7</b> is a bidirectional I/O port pin. <b>FD[7]</b> is the bidirectional FIFO/GPIF data bus.
<b>PORT C</b>							
72	57			PC0 or GPIFADR0	I/O/Z	I (PC0)	Multiplexed pin whose function is selected by PORTCCFG.0 <b>PC0</b> is a bidirectional I/O port pin. <b>GPIFADR0</b> is a GPIF address output pin.
73	58			PC1 or GPIFADR1	I/O/Z	I (PC1)	Multiplexed pin whose function is selected by PORTCCFG.1 <b>PC1</b> is a bidirectional I/O port pin. <b>GPIFADR1</b> is a GPIF address output pin.
74	59			PC2 or GPIFADR2	I/O/Z	I (PC2)	Multiplexed pin whose function is selected by PORTCCFG.2 <b>PC2</b> is a bidirectional I/O port pin. <b>GPIFADR2</b> is a GPIF address output pin.
75	60			PC3 or GPIFADR3	I/O/Z	I (PC3)	Multiplexed pin whose function is selected by PORTCCFG.3 <b>PC3</b> is a bidirectional I/O port pin. <b>GPIFADR3</b> is a GPIF address output pin.
76	61			PC4 or GPIFADR4	I/O/Z	I (PC4)	Multiplexed pin whose function is selected by PORTCCFG.4 <b>PC4</b> is a bidirectional I/O port pin. <b>GPIFADR4</b> is a GPIF address output pin.

**Table 4-1. FX2 Pin Descriptions** (continued)<sup>[5]</sup>

128 TQFP	100 TQFP	56 SSOP	56 QFN	Name	Type	Default	Description
77	62			PC5 or GPIFADR5	I/O/Z	I (PC5)	Multiplexed pin whose function is selected by PORTCCFG.5 <b>PC5</b> is a bidirectional I/O port pin. <b>GPIFADR5</b> is a GPIF address output pin.
78	63			PC6 or GPIFADR6	I/O/Z	I (PC6)	Multiplexed pin whose function is selected by PORTCCFG.6 <b>PC6</b> is a bidirectional I/O port pin. <b>GPIFADR6</b> is a GPIF address output pin.
79	64			PC7 or GPIFADR7	I/O/Z	I (PC7)	Multiplexed pin whose function is selected by PORTCCFG.7 <b>PC7</b> is a bidirectional I/O port pin. <b>GPIFADR7</b> is a GPIF address output pin.
<b>PORT D</b>							
102	80	52	45	PD0 or FD[8]	I/O/Z	I (PD0)	Multiplexed pin whose function is selected by the IFCONFIG[1..0] and EPxFIFCFG.0 (wordwide) bits. <b>FD[8]</b> is the bidirectional FIFO/GPIF data bus.
103	81	53	46	PD1 or FD[9]	I/O/Z	I (PD1)	Multiplexed pin whose function is selected by the IFCONFIG[1..0] and EPxFIFCFG.0 (wordwide) bits. <b>FD[9]</b> is the bidirectional FIFO/GPIF data bus.
104	82	54	47	PD2 or FD[10]	I/O/Z	I (PD2)	Multiplexed pin whose function is selected by the IFCONFIG[1..0] and EPxFIFCFG.0 (wordwide) bits. <b>FD[10]</b> is the bidirectional FIFO/GPIF data bus.
105	83	55	48	PD3 or FD[11]	I/O/Z	I (PD3)	Multiplexed pin whose function is selected by the IFCONFIG[1..0] and EPxFIFCFG.0 (wordwide) bits. <b>FD[11]</b> is the bidirectional FIFO/GPIF data bus.
121	95	56	49	PD4 or FD[12]	I/O/Z	I (PD4)	Multiplexed pin whose function is selected by the IFCONFIG[1..0] and EPxFIFCFG.0 (wordwide) bits. <b>FD[12]</b> is the bidirectional FIFO/GPIF data bus.
122	96	1	50	PD5 or FD[13]	I/O/Z	I (PD5)	Multiplexed pin whose function is selected by the IFCONFIG[1..0] and EPxFIFCFG.0 (wordwide) bits. <b>FD[13]</b> is the bidirectional FIFO/GPIF data bus.
123	97	2	51	PD6 or FD[14]	I/O/Z	I (PD6)	Multiplexed pin whose function is selected by the IFCONFIG[1..0] and EPxFIFCFG.0 (wordwide) bits. <b>FD[14]</b> is the bidirectional FIFO/GPIF data bus.
124	98	3	52	PD7 or FD[15]	I/O/Z	I (PD7)	Multiplexed pin whose function is selected by the IFCONFIG[1..0] and EPxFIFCFG.0 (wordwide) bits. <b>FD[15]</b> is the bidirectional FIFO/GPIF data bus.
<b>Port E</b>							
108	86			PE0 or T0OUT	I/O/Z	I (PE0)	Multiplexed pin whose function is selected by the PORTECFG.0 bit. <b>PE0</b> is a bidirectional I/O port pin. <b>T0OUT</b> is an active-HIGH signal from 8051 Timer-counter0. T0OUT outputs a high level for one CLKOUT clock cycle when Timer0 overflows. If Timer0 is operated in Mode 3 (two separate timer/counters), T0OUT is active when the low byte timer/counter overflows.
109	87			PE1 or T1OUT	I/O/Z	I (PE1)	Multiplexed pin whose function is selected by the PORTECFG.1 bit. <b>PE1</b> is a bidirectional I/O port pin. <b>T1OUT</b> is an active-HIGH signal from 8051 Timer-counter1. T1OUT outputs a high level for one CLKOUT clock cycle when Timer1 overflows. If Timer1 is operated in Mode 3 (two separate timer/counters), T1OUT is active when the low byte timer/counter overflows.

**Table 4-1. FX2 Pin Descriptions** (continued)<sup>[5]</sup>

128 TQFP	100 TQFP	56 SSOP	56 QFN	Name	Type	Default	Description
110	88			PE2 or T2OUT	I/O/Z	I (PE2)	Multiplexed pin whose function is selected by the PORTECFG.2 bit. <b>PE2</b> is a bidirectional I/O port pin. <b>T2OUT</b> is the active-HIGH output signal from 8051 Timer2. T2OUT is active (HIGH) for one clock cycle when Timer/Counter 2 overflows.
111	89			PE3 or RXD0OUT	I/O/Z	I (PE3)	Multiplexed pin whose function is selected by the PORTECFG.3 bit. <b>PE3</b> is a bidirectional I/O port pin. <b>RXD0OUT</b> is an active-HIGH signal from 8051 UART0. If RXD0OUT is selected and UART0 is in Mode 0, this pin provides the output data for UART0 only when it is in sync mode. Otherwise it is a 1.
112	90			PE4 or RXD1OUT	I/O/Z	I (PE4)	Multiplexed pin whose function is selected by the PORTECFG.4 bit. <b>PE4</b> is a bidirectional I/O port pin. <b>RXD1OUT</b> is an active-HIGH output from 8051 UART1. When RXD1OUT is selected and UART1 is in Mode 0, this pin provides the output data for UART1 only when it is in sync mode. In Modes 1, 2, and 3, this pin is HIGH.
113	91			PE5 or INT6	I/O/Z	I (PE5)	Multiplexed pin whose function is selected by the PORTECFG.5 bit. <b>PE5</b> is a bidirectional I/O port pin. <b>INT6</b> is the 8051 INT5 interrupt request input signal. The INT6 pin is edge-sensitive, active HIGH.
114	92			PE6 or T2EX	I/O/Z	I (PE6)	Multiplexed pin whose function is selected by the PORTECFG.6 bit. <b>PE6</b> is a bidirectional I/O port pin. <b>T2EX</b> is an active-high input signal to the 8051 Timer2. T2EX reloads timer 2 on its falling edge. T2EX is active only if the EXEN2 bit is set in T2CON.
115	93			PE7 or GPIFADR8	I/O/Z	I (PE7)	Multiplexed pin whose function is selected by the PORTECFG.7 bit. <b>PE7</b> is a bidirectional I/O port pin. <b>GPIFADR8</b> is a GPIF address output pin.
4	3	8	1	RDY0 or SLRD	Input	N/A	Multiplexed pin whose function is selected by the following bits: IFCONFIG[1..0]. <b>RDY0</b> is a GPIF input signal. <b>SLRD</b> is the input-only read strobe with programmable polarity (FIFOPOLAR.3) for the slave FIFOs connected to FDI[7..0] or FDI[15..0].
5	4	9	2	RDY1 or SLWR	Input	N/A	Multiplexed pin whose function is selected by the following bits: IFCONFIG[1..0]. <b>RDY1</b> is a GPIF input signal. <b>SLWR</b> is the input-only write strobe with programmable polarity (FIFOPOLAR.2) for the slave FIFOs connected to FDI[7..0] or FDI[15..0].
6	5			RDY2	Input	N/A	<b>RDY2</b> is a GPIF input signal.
7	6			RDY3	Input	N/A	<b>RDY3</b> is a GPIF input signal.
8	7			RDY4	Input	N/A	<b>RDY4</b> is a GPIF input signal.
9	8			RDY5	Input	N/A	<b>RDY5</b> is a GPIF input signal.

**Table 4-1. FX2 Pin Descriptions** (continued)<sup>[5]</sup>

128 TQFP	100 TQFP	56 SSOP	56 QFN	Name	Type	Default	Description
69	54	36	29	CTL0 or FLAGA	Output	H	Multiplexed pin whose function is selected by the following bits: IFCONFIG[1..0]. <b>CTL0</b> is a GPIF control output. <b>FLAGA</b> is a programmable slave-FIFO output status flag signal. Defaults to programmable for the FIFO selected by the FIFOADR[1:0] pins.
70	55	37	30	CTL1 or FLAGB	Output	H	Multiplexed pin whose function is selected by the following bits: IFCONFIG[1..0]. <b>CTL1</b> is a GPIF control output. <b>FLAGB</b> is a programmable slave-FIFO output status flag signal. Defaults to FULL for the FIFO selected by the FIFOADR[1:0] pins.
71	56	38	31	CTL2 or FLAGC	Output	H	Multiplexed pin whose function is selected by the following bits: IFCONFIG[1..0]. <b>CTL2</b> is a GPIF control output. <b>FLAGC</b> is a programmable slave-FIFO output status flag signal. Defaults to EMPTY for the FIFO selected by the FIFOADR[1:0] pins.
66	51			CTL3	Output	H	<b>CTL3</b> is a GPIF control output.
67	52			CTL4	Output	H	<b>CTL4</b> is a GPIF control output.
98	76			CTL5	Output	H	<b>CTL5</b> is a GPIF control output.
32	26	20	13	IFCLK	I/O/Z	Z	Interface Clock, used for synchronously clocking data into or out of the slave FIFOs. IFCLK also serves as a timing reference for all slave FIFO control signals and GPIF. When internal clocking, IFCONFIG.7 = 1, is used the IFCLK pin can be configured to output 30/48 MHz by bits IFCONFIG.5 and IFCONFIG.6. IFCLK may be inverted, whether internally or externally sourced, by setting the bit IFCONFIG.4 =1.
28	22			INT4	Input	N/A	<b>INT4</b> is the 8051 INT4 interrupt request input signal. The INT4 pin is edge-sensitive, active HIGH.
106	84			INT5#	Input	N/A	<b>INT5#</b> is the 8051 INT5 interrupt request input signal. The INT5 pin is edge-sensitive, active LOW.
31	25			T2	Input	N/A	<b>T2</b> is the active-HIGH T2 input signal to 8051 Timer2, which provides the input to Timer2 when C/T2 = 1. When C/T2 = 0, Timer2 does not use this pin.
30	24			T1	Input	N/A	<b>T1</b> is the active-HIGH T1 signal for 8051 Timer1, which provides the input to Timer1 when C/T1 is 1. When C/T1 is 0, Timer1 does not use this bit.
29	23			T0	Input	N/A	<b>T0</b> is the active-HIGH T0 signal for 8051 Timer0, which provides the input to Timer0 when C/T0 is 1. When C/T0 is 0, Timer0 does not use this bit.
53	43			RXD1	Input	N/A	<b>RXD1</b> is an active-HIGH input signal for 8051 UART1, which provides data to the UART in all modes.
52	42			TXD1	Output	H	<b>TXD1</b> is an active-HIGH output pin from 8051 UART1, which provides the output clock in sync mode, and the output data in async mode.
51	41			RXD0	Input	N/A	<b>RXD0</b> is the active-HIGH RXD0 input to 8051 UART0, which provides data to the UART in all modes.
50	40			TXD0	Output	H	<b>TXD0</b> is the active-HIGH TXD0 output from 8051 UART0, which provides the output clock in sync mode, and the output data in async mode.
42				CS#	Output	H	<b>CS#</b> is the active-LOW chip select for external memory.
41	32			WR#	Output	H	<b>WR#</b> is the active-LOW write strobe output for external memory.



**Table 4-1. FX2 Pin Descriptions (continued)<sup>[5]</sup>**

128 TQFP	100 TQFP	56 SSOP	56 QFN	Name	Type	Default	Description
40	31			RD#	Output	H	<b>RD#</b> is the active-LOW read strobe output for external memory.
38				OE#	Output	H	<b>OE#</b> is the active-LOW output enable for external memory.
33	27	21	14	Reserved	Input	N/A	Reserved. Connect to ground.
101	79	51	44	WAKEUP	Input	N/A	<b>USB Wakeup.</b> If the 8051 is in suspend, asserting this pin starts up the oscillator and interrupts the 8051 to allow it to exit the suspend mode. Holding WAKEUP asserted inhibits the EZ-USB <sup>®</sup> chip from suspending. This pin has programmable polarity (WAKEUP.4).
36	29	22	15	SCL	OD	Z	<b>Clock</b> for the <b>I<sup>2</sup>C-compatible interface</b> . Connect to V <sub>CC</sub> with a 2.2K resistor, <b>even if no I<sup>2</sup>C-compatible peripheral is attached</b> .
37	30	23	16	SDA	OD	Z	<b>Data</b> for <b>I<sup>2</sup>C-compatible interface</b> . Connect to V <sub>CC</sub> with a 2.2K resistor, <b>even if no I<sup>2</sup>C-compatible peripheral is attached</b> .
2	1	6	55	V <sub>CC</sub>	Power	N/A	V <sub>CC</sub> . Connect to 3.3V power source.
17	16	14	7	V <sub>CC</sub>	Power	N/A	V <sub>CC</sub> . Connect to 3.3V power source.
26	20	18	11	V <sub>CC</sub>	Power	N/A	V <sub>CC</sub> . Connect to 3.3V power source.
43	33	24	17	V <sub>CC</sub>	Power	N/A	V <sub>CC</sub> . Connect to 3.3V power source.
48	38	34	27	V <sub>CC</sub>	Power	N/A	V <sub>CC</sub> . Connect to 3.3V power source.
64	49	39	32	V <sub>CC</sub>	Power	N/A	V <sub>CC</sub> . Connect to 3.3V power source.
68	53	50	43	V <sub>CC</sub>	Power	N/A	V <sub>CC</sub> . Connect to 3.3V power source.
81	66			V <sub>CC</sub>	Power	N/A	V <sub>CC</sub> . Connect to 3.3V power source.
100	78			V <sub>CC</sub>	Power	N/A	V <sub>CC</sub> . Connect to 3.3V power source.
107	85			V <sub>CC</sub>	Power	N/A	V <sub>CC</sub> . Connect to 3.3V power source.
3	2	4	53	GND	Ground	N/A	Ground.
20	19	7	56	GND	Ground	N/A	Ground.
27	21	17	10	GND	Ground	N/A	Ground.
49	39	19	12	GND	Ground	N/A	Ground.
58	48	33	26	GND	Ground	N/A	Ground.
65	50	35	28	GND	Ground	N/A	Ground.
80	65	48	41	GND	Ground	N/A	Ground.
93	75			GND	Ground	N/A	Ground.
116	94			GND	Ground	N/A	Ground.
125	99			GND	Ground	N/A	Ground.
14	13			NC	N/A	N/A	No-connect. This pin must be left open.
15	14			NC	N/A	N/A	No-connect. This pin must be left open.
16	15			NC	N/A	N/A	No-connect. This pin must be left open.



## 5.0 Register Summary

FX2 register bit definitions are described in the FX2 TRM in greater detail.

**Table 5-1. FX2 Register Summary**

Hex	Size	Name	Description	b7	b6	b5	b4	b3	b2	b1	b0	Default	Access
<b>GPIF Waveform Memories</b>													
E400	128	WAVEDATA	GPIF Waveform Descriptor 0, 1, 2, 3 data	D7	D6	D5	D4	D3	D2	D1	D0	xxxxxxx	RW
E480	384	reserved											
<b>GENERAL CONFIGURATION</b>													
E600	1	CPUCS	CPU Control & Status	0	0	PORTCSTB	CLKSPD1	CLKSPD0	CLKINV	CLKOE	8051RES	00000010	rrbbbbb
E601	1	IFCONFIG	Interface Configuration (Ports, GPIF, slave FIFOs)	IFCLKSRC	3048MHZ	IFCLKOE	IFCLKPOL	ASYNC	GSTATE	IFCFG1	IFCFG0	11000000	RW
E602	1	PINFLAGSAB <sup>[6]</sup>	Slave FIFO FLA and FLAGB Pin Configuration	FLAGB3	FLAGB2	FLAGB1	FLAGB0	FLAGA3	FLAGA2	FLAGA1	FLAGA0	00000000	RW
E603	1	PINFLAGSCD <sup>[6]</sup>	Slave FIFO FLAGC and FLAGD Pin Configuration	FLAGD3	FLAGD2	FLAGD1	FLAGD0	FLAGC3	FLAGC2	FLAGC1	FLAGC0	01000000	RW
E604	1	FIFORESET <sup>[6]</sup>	Restore FIFOS to default state	NAKALL	0	0	0	EP3	EP2	EP1	EP0	xxxxxxx	W
E605	1	BREAKPT	Breakpoint Control	0	0	0	0	BREAK	BPPULSE	BPEN	0	00000000	rrrrbbbr
E606	1	BPADDRH	Breakpoint Address H	A15	A14	A13	A12	A11	A10	A9	A8	xxxxxxx	RW
E607	1	BPADDRL	Breakpoint Address L	A7	A6	A5	A4	A3	A2	A1	A0	xxxxxxx	RW
E608	1	UART230	230 Kbaud internally generated ref. clock	0	0	0	0	0	0	230UART1	230UART0	00000000	rrrrrb
E609	1	FIFOPINPOLAR <sup>[6]</sup>	Slave FIFO Interface pins polarity	0	0	PKTEND	SLOE	SLRD	SLWR	EF	FF	00000000	rrbbbbb
E60A	1	REVID	Chip Revision	rv7	rv6	rv5	rv4	rv3	rv2	rv1	rv0	Rev A, B - 00000000 Rev C, D - 00000010 Rev E - 00000100	R
E60B	1	REVCTL <sup>[6]</sup>	Chip Revision Control	0	0	0	0	0	0	dyn_out	enh_pkt	00000000	rrrrrb
<b>UDMA</b>													
E60C	1	GPIFHOLDTIME	MSTB Hold Time (for UDMA)	0	0	0	0	0	0	HOLDTIME1	HOLDTIME0	00000000	rrrrrb
	3	reserved											
<b>ENDPOINT CONFIGURATION</b>													
E610	1	EP1OUTCFG	Endpoint 1-OUT Configuration	VALID	0	TYPE1	TYPE0	0	0	0	0	10100000	brbrrrr
E611	1	EP1INCFG	Endpoint 1-IN Configuration	VALID	0	TYPE1	TYPE0	0	0	0	0	10100000	brbrrrr
E612	1	EP2CFG	Endpoint 2 Configuration	VALID	DIR	TYPE1	TYPE0	SIZE	0	BUF1	BUF0	10100010	bbbbbrbb
E613	1	EP4CFG	Endpoint 4 Configuration	VALID	DIR	TYPE1	TYPE0	0	0	0	0	10100000	bbbbrrrr
E614	1	EP6CFG	Endpoint 6 Configuration	VALID	DIR	TYPE1	TYPE0	SIZE	0	BUF1	BUF0	11100010	bbbbbrbb
E615	1	EP8CFG	Endpoint 8 Configuration	VALID	DIR	TYPE1	TYPE0	0	0	0	0	11100000	bbbbrrrr
	2	reserved											
E618	1	EP2FIFOCFG <sup>[6]</sup>	Endpoint 2 / slave FIFO configuration	0	INFM1	OEP1	AUTOOUT	AUTOIN	ZEROLENIN	0	WORDWIDE	00000101	rbbbbbrb
E619	1	EP4FIFOCFG <sup>[6]</sup>	Endpoint 4 / slave FIFO configuration	0	INFM1	OEP1	AUTOOUT	AUTOIN	ZEROLENIN	0	WORDWIDE	00000101	rbbbbbrb
E61A	1	EP6FIFOCFG <sup>[6]</sup>	Endpoint 6 / slave FIFO configuration	0	INFM1	OEP1	AUTOOUT	AUTOIN	ZEROLENIN	0	WORDWIDE	00000101	rbbbbbrb
E61B	1	EP8FIFOCFG <sup>[6]</sup>	Endpoint 8 / slave FIFO configuration	0	INFM1	OEP1	AUTOOUT	AUTOIN	ZEROLENIN	0	WORDWIDE	00000101	rbbbbbrb
	4	reserved											
E620	1	EP2AUTOINLENH <sup>[6]</sup>	Endpoint 2 AUTOIN Packet Length H	0	0	0	0	0	PL10	PL9	PL8	00000010	rrrrrb
E621	1	EP2AUTOINLENL <sup>[6]</sup>	Endpoint 2 AUTOIN Packet Length L	PL7	PL6	PL5	PL4	PL3	PL2	PL1	PL0	00000000	RW
E622	1	EP4AUTOINLENH <sup>[6]</sup>	Endpoint 4 AUTOIN Packet Length H	0	0	0	0	0	0	PL9	PL8	00000010	rrrrrb
E623	1	EP4AUTOINLENL <sup>[6]</sup>	Endpoint 4 AUTOIN Packet Length L	PL7	PL6	PL5	PL4	PL3	PL2	PL1	PL0	00000000	RW
E624	1	EP6AUTOINLENH <sup>[6]</sup>	Endpoint 6 AUTOIN Packet Length H	0	0	0	0	0	PL10	PL9	PL8	00000010	rrrrrb
E625	1	EP6AUTOINLENL <sup>[6]</sup>	Endpoint 6 AUTOIN Packet Length L	PL7	PL6	PL5	PL4	PL3	PL2	PL1	PL0	00000000	RW
E626	1	EP8AUTOINLENH <sup>[6]</sup>	Endpoint 8 AUTOIN Packet Length H	0	0	0	0	0	0	PL9	PL8	00000010	rrrrrb
E627	1	EP8AUTOINLENL <sup>[6]</sup>	Endpoint 8 AUTOIN Packet Length L	PL7	PL6	PL5	PL4	PL3	PL2	PL1	PL0	00000000	RW
	8	reserved											
E630	1	EP2FIFOPFH <sup>[6]</sup>	Endpoint 2 / slave FIFO Programmable Flag H	DECIS	PKTSTAT	IN:PKTS[2] OUT:PFC12	IN:PKTS[1] OUT:PFC11	IN:PKTS[0] OUT:PFC10	0	PFC9	PFC8	10001000	bbbbbrbb
E630	1	F.S.	Endpoint 2 / slave FIFO Programmable Flag H	DECIS	PKTSTAT	OUT:PFC12	OUT:PFC11	OUT:PFC10	0	PFC9	IN:PKTS[2] OUT:PFC8	10001000	bbbbbrbb
E631	1	H.S.	Endpoint 2 / slave FIFO Programmable Flag L	PFC7	PFC6	PFC5	PFC4	PFC3	PFC2	PFC1	PFC0	00000000	RW

Note:

- Read and writes to these register may require synchronization delay, see Technical Reference Manual for "Synchronization Delay."

**Table 5-1. FX2 Register Summary (continued)**

Hex	Size	Name	Description	b7	b6	b5	b4	b3	b2	b1	b0	Default	Access
E631	1	EP2FIFOPFL <sup>[6]</sup>	Endpoint 2 / slave FIFO Programmable Flag L	IN:PKTS[1] OUT:PFC7	IN:PKTS[0] OUT:PFC6	PFC5	PFC4	PFC3	PFC2	PFC1	PFC0	00000000	RW
E632	1	EP4FIFOPFH <sup>[6]</sup>	Endpoint 4 / slave FIFO Programmable Flag H	DECIS	PKTSTAT	0	IN: PKTS[1] OUT:PFC10	IN: PKTS[0] OUT:PFC9	0	0	PFC8	10001000	bbrbbrb
E632	1	EP4FIFOPFH <sup>[6]</sup>	Endpoint 4 / slave FIFO Programmable Flag H	DECIS	PKTSTAT	0	OUT:PFC10	OUT:PFC9	0	0	PFC8	10001000	bbrbbrb
E633	1	EP4FIFOPFL <sup>[6]</sup>	Endpoint 4 / slave FIFO Programmable Flag L	PFC7	PFC6	PFC5	PFC4	PFC3	PFC2	PFC1	PFC0	00000000	RW
E633	1	EP4FIFOPFL <sup>[6]</sup>	Endpoint 4 / slave FIFO Programmable Flag L	IN: PKTS[1] OUT:PFC7	IN: PKTS[0] OUT:PFC6	PFC5	PFC4	PFC3	PFC2	PFC1	PFC0	00000000	RW
E634	1	EP6FIFOPFH <sup>[6]</sup>	Endpoint 6 / slave FIFO Programmable Flag H	DECIS	PKTSTAT	IN:PKTS[2] OUT:PFC12	IN:PKTS[1] OUT:PFC11	IN:PKTS[0] OUT:PFC10	0	PFC9	PFC8	00001000	bbbbbrb
E634	1	EP6FIFOPFH <sup>[6]</sup>	Endpoint 6 / slave FIFO Programmable Flag H	DECIS	PKTSTAT	OUT:PFC12	OUT:PFC11	OUT:PFC10	0	PFC9	IN:PKTS[2] OUT:PFC8	00001000	bbbbbrb
E635	1	EP6FIFOPFL <sup>[6]</sup>	Endpoint 6 / slave FIFO Programmable Flag L	PFC7	PFC6	PFC5	PFC4	PFC3	PFC2	PFC1	PFC0	00000000	RW
E635	1	EP6FIFOPFL <sup>[6]</sup>	Endpoint 6 / slave FIFO Programmable Flag L	IN:PKTS[1] OUT:PFC7	IN:PKTS[0] OUT:PFC6	PFC5	PFC4	PFC3	PFC2	PFC1	PFC0	00000000	RW
E636	1	EP8FIFOPFH <sup>[6]</sup>	Endpoint 8 / slave FIFO Programmable Flag H	DECIS	PKTSTAT	0	IN: PKTS[1] OUT:PFC10	IN: PKTS[0] OUT:PFC9	0	0	PFC8	00001000	bbrbbrb
E636	1	EP8FIFOPFH <sup>[6]</sup>	Endpoint 8 / slave FIFO Programmable Flag H	DECIS	PKTSTAT	0	OUT:PFC10	OUT:PFC9	0	0	PFC8	00001000	bbrbbrb
E637	1	EP8FIFOPFL <sup>[6]</sup>	Endpoint 8 / slave FIFO Programmable Flag L	PFC7	PFC6	PFC5	PFC4	PFC3	PFC2	PFC1	PFC0	00000000	RW
E637	1	EP8FIFOPFL <sup>[6]</sup>	Endpoint 8 / slave FIFO Programmable Flag L	IN: PKTS[1] OUT:PFC7	IN: PKTS[0] OUT:PFC6	PFC5	PFC4	PFC3	PFC2	PFC1	PFC0	00000000	RW
	8	reserved											
E640	1	EP2ISOINPKTS	EP2 (if ISO) IN Packets per frame (1-3)	0	0	0	0	0	0	INPPF1	INPPF0	00000001	rrrrrb
E641	1	EP4ISOINPKTS	EP4 (if ISO) IN Packets per frame (1-3)	0	0	0	0	0	0	INPPF1	INPPF0	00000001	rrrrrb
E642	1	EP6ISOINPKTS	EP6 (if ISO) IN Packets per frame (1-3)	0	0	0	0	0	0	INPPF1	INPPF0	00000001	rrrrrb
E643	1	EP8ISOINPKTS	EP8 (if ISO) IN Packets per frame (1-3)	0	0	0	0	0	0	INPPF1	INPPF0	00000001	rrrrrb
	4	reserved											
E648	1	INPKTEND <sup>[6]</sup>	Force IN Packet End	Skip	0	0	0	EP3	EP2	EP1	EP0	xxxxxxx	R/W
E649	7	OUTPKTEND <sup>[6]</sup>	Force OUT Packet End	Skip	0	0	0	EP3	EP2	EP1	EP0	xxxxxxx	W
		<b>INTERRUPTS</b>											
E650	1	EP2FIFOIE <sup>[6]</sup>	Endpoint 2 slave FIFO Flag Interrupt Enable	0	0	0	0	EDGE PF	PF	EF	FF	00000000	RW
E651	1	EP2FIFOIRQ <sup>[6]</sup>	Endpoint 2 slave FIFO Flag Interrupt Request	0	0	0	0	0	PF	EF	FF	00000xxx	RW
E652	1	EP4FIFOIE <sup>[6]</sup>	Endpoint 4 slave FIFO Flag Interrupt Enable	0	0	0	0	EDGE PF	PF	EF	FF	00000000	RW
E653	1	EP4FIFOIRQ <sup>[6]</sup>	Endpoint 4 slave FIFO Flag Interrupt Request	0	0	0	0	0	PF	EF	FF	00000xxx	RW
E654	1	EP6FIFOIE <sup>[6]</sup>	Endpoint 6 slave FIFO Flag Interrupt Enable	0	0	0	0	EDGE PF	PF	EF	FF	00000000	RW
E655	1	EP6FIFOIRQ <sup>[6]</sup>	Endpoint 6 slave FIFO Flag Interrupt Request	0	0	0	0	0	PF	EF	FF	00000xxx	RW
E656	1	EP8FIFOIE <sup>[6]</sup>	Endpoint 8 slave FIFO Flag Interrupt Enable	0	0	0	0	EDGE PF	PF	EF	FF	00000000	RW
E657	1	EP8FIFOIRQ <sup>[6]</sup>	Endpoint 8 slave FIFO Flag Interrupt Request	0	0	0	0	0	PF	EF	FF	00000xxx	RW
E658	1	IBNIE	IN-BULK-NAK Interrupt Enable	0	0	EP8	EP6	EP4	EP2	EP1	EP0	00000000	RW
E659	1	IBNIRQ	IN-BULK-NAK interrupt Request	0	0	EP8	EP6	EP4	EP2	EP1	EP0	00xxxxx	RW
E65A	1	NAKIE	Endpoint Ping-NAK / IBN Interrupt Enable	EP8	EP6	EP4	EP2	EP1	EP0	0	IBN	00000000	RW
E65B	1	NAKIRQ	Endpoint Ping-NAK / IBN Interrupt Request	EP8	EP6	EP4	EP2	EP1	EP0	0	IBN	xxxxxxx	RW
E65C	1	USBIE	USB Int Enables	0	EP0ACK	HSGRANT	URES	SUSP	SUTOK	SOF	SUDAV	00000000	RW
E65D	1	USBIRQ	USB Interrupt Requests	0	EP0ACK	HSGRANT	URES	SUSP	SUTOK	SOF	SUDAV	0xxxxxxx	RW
E65E	1	EPIE	Endpoint Interrupt Enables	EP8	EP6	EP4	EP2	EP1OUT	EP1IN	EP0OUT	EP0IN	00000000	RW
E65F	1	EPIRQ	Endpoint Interrupt Requests	EP8	EP6	EP4	EP2	EP1OUT	EP1IN	EP0OUT	EP0IN	xxxxxxx	RW
E660	1	GPIFIE <sup>[6]</sup>	GPIF Interrupt Enable	0	0	0	0	0	0	GPIFWF	GPIFDONE	00000000	RW
E661	1	GPIFIRQ <sup>[6]</sup>	GPIF Interrupt Request	0	0	0	0	0	0	GPIFWF	GPIFDONE	000000xx	RW
E662	1	USBERRIE	USB Error Interrupt Enables	ISOEP8	ISOEP6	ISOEP4	ISOEP2	0	0	0	ERRLIMIT	00000000	RW
E663	1	USBERRIRQ	USB Error Interrupt Requests	ISOEP8	ISOEP6	ISOEP4	ISOEP2	0	0	0	ERRLIMIT	xxxx000x	RW
E664	1	ERRCNTLIM	USB Error counter and limit	EC3	EC2	EC1	EC0	LIMIT3	LIMIT2	LIMIT1	LIMIT0	xxxx0100	rrrrbbb
E665	1	CLRERRCNT	Clear Error Counter EC3:0	x	x	x	x	x	x	x	x	xxxxxxx	W
E666	1	INT2IVEC	Interrupt 2 (USB) Autovector	0	I2V4	I2V3	I2V2	I2V1	I2V0	0	0	00000000	R
E667	1	INT4IVEC	Interrupt 4 (slave FIFO & GPIF) Autovector	1	0	I4V3	I4V2	I4V1	I4V0	0	0	10000000	R
E668	1	INTSETUP	Interrupt 2&4 Setup	0	0	0	0	AV2EN	0	INT4SRC	AV4EN	00000000	RW

**Table 5-1. FX2 Register Summary (continued)**

Hex	Size	Name	Description	b7	b6	b5	b4	b3	b2	b1	b0	Default	Access
E669	7	reserved											
<b>INPUT / OUTPUT</b>													
E670	1	PORTACFG	I/O PORTA Alternate Configuration	FLAGD	SLCS	0	0	0	0	INT1	INT0	00000000	RW
E671	1	PORTCCFG	I/O PORTC Alternate Configuration	GPIFA7	GPIFA6	GPIFA5	GPIFA4	GPIFA3	GPIFA2	GPIFA1	GPIFA0	00000000	RW
E672	1	PORTECFG	I/O PORTE Alternate Configuration	GPIFA8	T2EX	INT6	RXD1OUT	RXD0OUT	T2OUT	T1OUT	T0OUT	00000000	RW
E673	5	reserved											
E678	1	I2CS	I <sup>2</sup> C-Compatible Bus Control & Status	START	STOP	LASTRD	ID1	ID0	BERR	ACK	DONE	000x000	bbbbrrrr
E679	1	I2DAT	I <sup>2</sup> C-Compatible Bus Data	d7	d6	d5	d4	d3	d2	d1	d0	xxxxxxx	RW
E67A	1	I2CTL	I <sup>2</sup> C-Compatible Bus Control	0	0	0	0	0	0	STOPIE	400KHZ	00000000	RW
E67B	1	XAUTODAT1	Autopt1 MOVX access, when APTREN=1	D7	D6	D5	D4	D3	D2	D1	D0	xxxxxxx	RW
E67C	1	XAUTODAT2	Autopt2 MOVX access, when APTREN=1	D7	D6	D5	D4	D3	D2	D1	D0	xxxxxxx	RW
<b>UDMA CRC</b>													
E67D	1	UDMACRCH <sup>[6]</sup>	UDMA CRC MSB	CRC15	CRC14	CRC13	CRC12	CRC11	CRC10	CRC9	CRC8	01001010	RW
E67E	1	UDMACRCL <sup>[6]</sup>	UDMA CRC LSB	CRC7	CRC6	CRC5	CRC4	CRC3	CRC2	CRC1	CRC0	10111010	RW
E67F	1	UDMACRC-QUALIFIER	UDMA CRC Qualifier	QENABLE	0	0	0	QSTATE	Q SIGNAL2	Q SIGNAL1	Q SIGNAL0	00000000	brrrbbbbb
<b>USB CONTROL</b>													
E680	1	USBCS	USB Control & Status	HSM	0	0	0	DISCON	NOSYNOSOF	RENUM	SIGRSUME	x0000000	rrrrbbbbb
E681	1	SUSPEND	Put chip into suspend	x	x	x	x	x	x	x	x	xxxxxxx	W
E682	1	WAKEUPCS	Wakeup Control & Status	WU2	WU	WU2POL	WUPOL	0	DPEN	WU2EN	WUEN	xx000101	bbbbbrbbb
E683	1	TOGCTL	Toggle Control	Q	S	R	IO	EP3	EP2	EP1	EP0	xxxxxxx	rbbbbbbbb
E684	1	USBFRAMEH	USB Frame count H	0	0	0	0	0	FC10	FC9	FC8	00000xxx	R
E685	1	USBFRAMEL	USB Frame count L	FC7	FC6	FC5	FC4	FC3	FC2	FC1	FC0	xxxxxxx	R
E686	1	MICROFRAME	Microframe count, 0-7	0	0	0	0	0	MF2	MF1	MF0	00000xxx	R
E687	1	FNADDR	USB Function address	0	FA6	FA5	FA4	FA3	FA2	FA1	FA0	0xxxxxxx	R
E688	2	reserved											
<b>ENDPOINTS</b>													
E68A	1	EP0BCH <sup>[6]</sup>	Endpoint 0 Byte Count H	(BC15)	(BC14)	(BC13)	(BC12)	(BC11)	(BC10)	(BC9)	(BC8)	xxxxxxx	RW
E68B	1	EP0BCL <sup>[6]</sup>	Endpoint 0 Byte Count L	(BC7)	BC6	BC5	BC4	BC3	BC2	BC1	BC0	xxxxxxx	RW
E68C	1	reserved											
E68D	1	EP1OUTBC	Endpoint 1 OUT Byte Count	0	BC6	BC5	BC4	BC3	BC2	BC1	BC0	0xxxxxxx	RW
E68E	1	reserved											
E68F	1	EP1INBC	Endpoint 1 IN Byte Count	0	BC6	BC5	BC4	BC3	BC2	BC1	BC0	0xxxxxxx	RW
E690	1	EP2BCH <sup>[6]</sup>	Endpoint 2 Byte Count H	0	0	0	0	0	BC10	BC9	BC8	00000xxx	RW
E691	1	EP2BCL <sup>[6]</sup>	Endpoint 2 Byte Count L	BC7/SKIP	BC6	BC5	BC4	BC3	BC2	BC1	BC0	xxxxxxx	RW
E692	2	reserved											
E694	1	EP4BCH <sup>[6]</sup>	Endpoint 4 Byte Count H	0	0	0	0	0	0	BC9	BC8	000000xx	RW
E695	1	EP4BCL <sup>[6]</sup>	Endpoint 4 Byte Count L	BC7/SKIP	BC6	BC5	BC4	BC3	BC2	BC1	BC0	xxxxxxx	RW
E696	2	reserved											
E698	1	EP6BCH <sup>[6]</sup>	Endpoint 6 Byte Count H	0	0	0	0	0	BC10	BC9	BC8	00000xxx	RW
E699	1	EP6BCL <sup>[6]</sup>	Endpoint 6 Byte Count L	BC7/SKIP	BC6	BC5	BC4	BC3	BC2	BC1	BC0	xxxxxxx	RW
E69A	2	reserved											
E69C	1	EP8BCH <sup>[6]</sup>	Endpoint 8 Byte Count H	0	0	0	0	0	0	BC9	BC8	000000xx	RW
E69D	1	EP8BCL <sup>[6]</sup>	Endpoint 8 Byte Count L	BC7/SKIP	BC6	BC5	BC4	BC3	BC2	BC1	BC0	xxxxxxx	RW
E69E	2	reserved											
E6A0	1	EP0CS	Endpoint 0 Control and Status	HSNAK	0	0	0	0	0	BUSY	STALL	10000000	bbbbbbbrb
E6A1	1	EP1OUTCS	Endpoint 1 OUT Control and Status	0	0	0	0	0	0	BUSY	STALL	00000000	bbbbbbbrb
E6A2	1	EP1INCS	Endpoint 1 IN Control and Status	0	0	0	0	0	0	BUSY	STALL	00000000	bbbbbbbrb
E6A3	1	EP2CS	Endpoint 2 Control and Status	0	NPAK2	NPAK1	NPAK0	FULL	EMPTY	0	STALL	00101000	rrrrrrrb
E6A4	1	EP4CS	Endpoint 4 Control and Status	0	0	NPAK1	NPAK0	FULL	EMPTY	0	STALL	00101000	rrrrrrrb
E6A5	1	EP6CS	Endpoint 6 Control and Status	0	NPAK2	NPAK1	NPAK0	FULL	EMPTY	0	STALL	00000100	rrrrrrrb
E6A6	1	EP8CS	Endpoint 8 Control and Status	0	0	NPAK1	NPAK0	FULL	EMPTY	0	STALL	00000100	rrrrrrrb
E6A7	1	EP2FIFOFLGS	Endpoint 2 slave FIFO Flags	0	0	0	0	0	PF	EF	FF	00000010	R
E6A8	1	EP4FIFOFLGS	Endpoint 4 slave FIFO Flags	0	0	0	0	0	PF	EF	FF	00000010	R
E6A9	1	EP6FIFOFLGS	Endpoint 6 slave FIFO Flags	0	0	0	0	0	PF	EF	FF	00000110	R
E6AA	1	EP8FIFOFLGS	Endpoint 8 slave FIFO Flags	0	0	0	0	0	PF	EF	FF	00000110	R
E6AB	1	EP2FIFOBCH	Endpoint 2 slave FIFO total byte count H	0	0	0	BC12	BC11	BC10	BC9	BC8	00000000	R

**Table 5-1. FX2 Register Summary (continued)**

Hex	Size	Name	Description	b7	b6	b5	b4	b3	b2	b1	b0	Default	Access
E6A C	1	EP2FIFOBCL	Endpoint 2 slave FIFO total byte count L	BC7	BC6	BC5	BC4	BC3	BC2	BC1	BC0	00000000	R
E6A D	1	EP4FIFOBCH	Endpoint 4 slave FIFO total byte count H	0	0	0	0	0	BC10	BC9	BC8	00000000	R
E6AE	1	EP4FIFOBCL	Endpoint 4 slave FIFO total byte count L	BC7	BC6	BC5	BC4	BC3	BC2	BC1	BC0	00000000	R
E6AF	1	EP6FIFOBCH	Endpoint 6 slave FIFO total byte count H	0	0	0	0	BC11	BC10	BC9	BC8	00000000	R
E6B0	1	EP6FIFOBCL	Endpoint 6 slave FIFO total byte count L	BC7	BC6	BC5	BC4	BC3	BC2	BC1	BC0	00000000	R
E6B1	1	EP8FIFOBCH	Endpoint 8 slave FIFO total byte count H	0	0	0	0	0	BC10	BC9	BC8	00000000	R
E6B2	1	EP8FIFOBCL	Endpoint 8 slave FIFO total byte count L	BC7	BC6	BC5	BC4	BC3	BC2	BC1	BC0	00000000	R
E6B3	1	SUDPTRH	Setup Data Pointer high address byte	A15	A14	A13	A12	A11	A10	A9	A8	xxxxxxx	RW
E6B4	1	SUDPTRL	Setup Data Pointer low address byte	A7	A6	A5	A4	A3	A2	A1	0	xxxxxxx0	bbbbbbbr
E6B5	1	SUDPTRCTL	Setup Data Pointer Auto Mode	0	0	0	0	0	0	0	SDPAUTO	00000001	RW
	2	reserved											
E6B8	8	SETUPDAT	8 bytes of SETUP data	D7	D6	D5	D4	D3	D2	D1	D0	xxxxxxx	R
			SETUPDAT[0] = bmRequestType										
			SETUPDAT[1] = bmRequest										
			SETUPDAT[2:3] = wValue										
			SETUPDAT[4:5] = wIndex										
			SETUPDAT[6:7] = wLength										
		<b>GPIF</b>											
E6C0	1	GPIFWFSELECT	Waveform Selector	SINGLEWR1	SINGLEWR0	SINGLERD1	SINGLERD0	FIFOWR1	FIFOWR0	FIFORD1	FIFORD0	11100100	RW
E6C1	1	GPIFIDLECS	GPIF Done, GPIF IDLE drive mode	DONE	0	0	0	0	0	0	IDLEDRV	10000000	RW
E6C2	1	GPIFIDLECTL	Inactive Bus, CTL states	0	0	CTL5	CTL4	CTL3	CTL2	CTL1	CTL0	11111111	RW
E6C3	1	GPIFCTLCFG	CTL Drive Type	TRICTL	0	CTL5	CTL4	CTL3	CTL2	CTL1	CTL0	00000000	RW
E6C4	1	GPIFADRH <sup>[6]</sup>	GPIF Address H	0	0	0	0	0	0	0	GPIFA8	00000000	RW
E6C5	1	GPIFADRL <sup>[6]</sup>	GPIF Address L	GPIFA7	GPIFA6	GPIFA5	GPIFA4	GPIFA3	GPIFA2	GPIFA1	GPIFA0	00000000	RW
		<b>FLOWSTATE</b>											
E6C6	1	FLOWSTATE	Flowstate Enable and Selector	FSE	0	0	0	0	FS2	FS1	FS0	00000000	brrrrbb
E6C7	1	FLOWLOGIC	Flowstate Logic	LFUNC1	LFUNC0	TERMA2	TERMA1	TERMA0	TERMB2	TERMB1	TERMB0	00000000	RW
E6C8	1	FLOWEQ0CTL	CTL-Pin States in Flowstate (when Logic = 0)	CTL0E3	CTL0E2	CTL0E1/CTL5	CTL0E0/CTL4	CTL3	CTL2	CTL1	CTL0	00000000	RW
E6C9	1	FLOWEQ1CTL	CTL-Pin States in Flowstate (when Logic = 1)	CTL0E3	CTL0E2	CTL0E1/CTL5	CTL0E0/CTL4	CTL3	CTL2	CTL1	CTL0	00000000	RW
E6C A	1	FLOWHOLDOFF	Holdoff Configuration	HOPERIOD3	HOPERIOD2	HOPERIOD1	HOPERIOD0	HOSTATE	HOCTL2	HOCTL1	HOCTL0	00010010	RW
E6C B	1	FLOWSTB	Flowstate Strobe Configuration	SLAVE	RDYASYNC	CTLTOGL	SUSTAIN	0	MSTB2	MSTB1	MSTB0	00100000	RW
E6C C	1	FLOWSTBEDGE	Flowstate Rising/Falling Edge Configuration	0	0	0	0	0	FALLING	RISING		00000001	rrrrrbb
E6C D	1	FLOWSTBPERIOD	Master-Strobe Half-Period	D7	D6	D5	D4	D3	D2	D1	D0	00000010	RW
E6C E	1	GPIFTCB3 <sup>[6]</sup>	GPIF Transaction Count Byte 3	TC31	TC30	TC29	TC28	TC27	TC26	TC25	TC24	00000000	RW
E6CF	1	GPIFTCB2 <sup>[6]</sup>	GPIF Transaction Count Byte 2	TC23	TC22	TC21	TC20	TC19	TC18	TC17	TC16	00000000	RW
E6D0	1	GPIFTCB1 <sup>[6]</sup>	GPIF Transaction Count Byte 1	TC15	TC14	TC13	TC12	TC11	TC10	TC9	TC8	00000000	RW
E6D1	1	GPIFTCB0 <sup>[6]</sup>	GPIF Transaction Count Byte 0	TC7	TC6	TC5	TC4	TC3	TC2	TC1	TC0	00000001	RW
	2	reserved										00000000	RW
		reserved											
		reserved											
E6D2	1	EP2GPIFFLGSEL <sup>[6]</sup>	Endpoint 2 GPIF Flag select	0	0	0	0	0	0	FS1	FS0	00000000	RW
E6D3	1	EP2GPIFFSTOP	Endpoint 2 GPIF stop transaction on prog. flag	0	0	0	0	0	0	0	FIFO2FLAG	00000000	RW
E6D4	1	EP2GPIFTRIG <sup>[6]</sup>	Endpoint 2 GPIF Trigger	x	x	x	x	x	x	x	x	xxxxxxx	W
	3	reserved											
		reserved											
		reserved											
E6D A	1	EP4GPIFFLGSEL <sup>[6]</sup>	Endpoint 4 GPIF Flag select	0	0	0	0	0	0	FS1	FS0	00000000	RW
E6D B	1	EP4GPIFFSTOP	Endpoint 4 GPIF stop transaction on GPIF Flag	0	0	0	0	0	0	0	FIFO4FLAG	00000000	RW
E6D C	1	EP4GPIFTRIG <sup>[6]</sup>	Endpoint 4 GPIF Trigger	x	x	x	x	x	x	x	x	xxxxxxx	W
	3	reserved											

**Table 5-1. FX2 Register Summary (continued)**

Hex	Size	Name	Description	b7	b6	b5	b4	b3	b2	b1	b0	Default	Access
		reserved											
		reserved											
E6E2	1	EP6GPIFFLGSEL <sup>[6]</sup>	Endpoint 6 GPIF Flag select	0	0	0	0	0	0	FS1	FS0	00000000	RW
E6E3	1	EP6GPIPFSTOP	Endpoint 6 GPIF stop transaction on prog. flag	0	0	0	0	0	0	0	FIFO6FLAG	00000000	RW
E6E4	1	EP6GPIFTRIG <sup>[6]</sup>	Endpoint 6 GPIF Trigger	x	x	x	x	x	x	x	x	xxxxxxx	W
	3	reserved											
		reserved											
		reserved											
E6EA	1	EP8GPIFFLGSEL <sup>[6]</sup>	Endpoint 8 GPIF Flag select	0	0	0	0	0	0	FS1	FS0	00000000	RW
E6EB	1	EP8GPIPFSTOP	Endpoint 8 GPIF stop transaction on prog. flag	0	0	0	0	0	0	0	FIFO8FLAG	00000000	RW
E6EC	1	EP8GPIFTRIG <sup>[6]</sup>	Endpoint 8 GPIF Trigger	x	x	x	x	x	x	x	x	xxxxxxx	W
	3	reserved											
E6F0	1	XGPIFSGLDATH	GPIF Data H (16-bit mode only)	D15	D14	D13	D12	D11	D10	D9	D8	xxxxxxx	RW
E6F1	1	XGPIFSGLDATLX	Read/Write GPIF Data L & trigger transaction	D7	D6	D5	D4	D3	D2	D1	D0	xxxxxxx	RW
E6F2	1	XGPIFSGLDATL-NOX	Read GPIF Data L, no transaction trigger	D7	D6	D5	D4	D3	D2	D1	D0	xxxxxxx	R
E6F3	1	GPIFREADYCFG	Internal RDY, Sync/Async, RDY pin states	INTRDY	SAS	TCXRDY5	0	0	0	0	0	00000000	bbbrrrr
E6F4	1	GPIFREADYSTAT	GPIF Ready Status	0	0	RDY5	RDY4	RDY3	RDY2	RDY1	RDY0	00xxxxx	R
E6F5	1	GPIFABORT	Abort GPIF Waveforms	x	x	x	x	x	x	x	x	xxxxxxx	W
E6F6	2	reserved											
		<b>ENDPOINT BUFFERS</b>											
E740	64	EP0BUF	EP0-IN/-OUT buffer	D7	D6	D5	D4	D3	D2	D1	D0	xxxxxxx	RW
E780	64	EP10UTBUF	EP1-OUT buffer	D7	D6	D5	D4	D3	D2	D1	D0	xxxxxxx	RW
E7C0	64	EP1INBUF	EP1-IN buffer	D7	D6	D5	D4	D3	D2	D1	D0	xxxxxxx	RW
	2048	reserved											
F000	1024	EP2FIFOBUF	512/1024-byte EP 2 / slave FIFO buffer (IN or OUT)	D7	D6	D5	D4	D3	D2	D1	D0	xxxxxxx	RW
F400	512	EP4FIFOBUF	512 byte EP 4 / slave FIFO buffer (IN or OUT)	D7	D6	D5	D4	D3	D2	D1	D0	xxxxxxx	RW
F600	512	reserved											
F800	1024	EP6FIFOBUF	512/1024-byte EP 6 / slave FIFO buffer (IN or OUT)	D7	D6	D5	D4	D3	D2	D1	D0	xxxxxxx	RW
FC00	512	EP8FIFOBUF	512 byte EP 8 / slave FIFO buffer (IN or OUT)	D7	D6	D5	D4	D3	D2	D1	D0	xxxxxxx	RW
FE00	512	reserved											
xxxx		<b>PC Compatible Configuration Byte</b>		0	DISCON	0	0	0	0	0	400KHZ	xxxxxxx <sup>[8]</sup>	n/a
		<b>Special Function Registers (SFRs)</b>											
80	1	IOA <sup>[7]</sup>	Port A (bit addressable)	D7	D6	D5	D4	D3	D2	D1	D0	xxxxxxx	RW
81	1	SP	Stack Pointer	D7	D6	D5	D4	D3	D2	D1	D0	00000111	RW
82	1	DPL0	Data Pointer 0 L	A7	A6	A5	A4	A3	A2	A1	A0	00000000	RW
83	1	DPH0	Data Pointer 0 H	A15	A14	A13	A12	A11	A10	A9	A8	00000000	RW
84	1	DPL1 <sup>[7]</sup>	Data Pointer 1 L	A7	A6	A5	A4	A3	A2	A1	A0	00000000	RW
85	1	DPH1 <sup>[7]</sup>	Data Pointer 1 H	A15	A14	A13	A12	A11	A10	A9	A8	00000000	RW
86	1	DPS <sup>[7]</sup>	Data Pointer 0/1 select	0	0	0	0	0	0	0	SEL	00000000	RW
87	1	PCON	Power Control	SMOD0	x	1	1	GF1	GF0	STOP	IDLE	00110000	RW
88	1	TCON	Timer/Counter Control (bit addressable)	TF1	TR1	TF0	TR0	IE1	IT1	IE0	IT0	00000000	RW
89	1	TMOD	Timer/Counter Mode Control	GATE	CT	M1	M0	GATE	CT	M1	M0	00000000	RW
8A	1	TL0	Timer 0 reload L	D7	D6	D5	D4	D3	D2	D1	D0	00000000	RW
8B	1	TL1	Timer 1 reload L	D7	D6	D5	D4	D3	D2	D1	D0	00000000	RW
8C	1	TH0	Timer 0 reload H	D15	D14	D13	D12	D11	D10	D9	D8	00000000	RW
8D	1	TH1	Timer 1 reload H	D15	D14	D13	D12	D11	D10	D9	D8	00000000	RW
8E	1	CKCON <sup>[7]</sup>	Clock Control	x	x	T2M	T1M	T0M	MD2	MD1	MD0	00000001	RW
8F	1	reserved											
90	1	IOB <sup>[7]</sup>	Port B (bit addressable)	D7	D6	D5	D4	D3	D2	D1	D0	xxxxxxx	RW
91	1	EXIF <sup>[7]</sup>	External Interrupt Flag(s)	IE5	IE4	PCINT	USBNT	1	0	0	0	00001000	RW
92	1	MPAGE <sup>[7]</sup>	Upper Addr Byte of MOVX using @R0 / @R1	A15	A14	A13	A12	A11	A10	A9	A8	00000000	RW
93	5	reserved											
98	1	SCON0	Serial Port 0 Control (bit addressable)	SM0_0	SM1_0	SM2_0	REN_0	TB8_0	RB8_0	TI_0	RI_0	00000000	RW
99	1	SBUF0	Serial Port 0 Data Buffer	D7	D6	D5	D4	D3	D2	D1	D0	00000000	RW

**Notes:**

7. SFRs not part of the standard 8051 architecture.
8. If no EEPROM is detected by the SIE then the default is 00000000.

**Table 5-1. FX2 Register Summary (continued)**

Hex	Size	Name	Description	b7	b6	b5	b4	b3	b2	b1	b0	Default	Access
9A	1	AUTOPTRH1 <sup>[7]</sup>	Autopointer 1 Address H	A15	A14	A13	A12	A11	A10	A9	A8	00000000	RW
9B	1	AUTOPTRL1 <sup>[7]</sup>	Autopointer 1 Address L	A7	A6	A5	A4	A3	A2	A1	A0	00000000	RW
9C	1	reserved											
9D	1	AUTOPTRH2 <sup>[7]</sup>	Autopointer 2 Address H	A15	A14	A13	A12	A11	A10	A9	A8	00000000	RW
9E	1	AUTOPTRL2 <sup>[7]</sup>	Autopointer 2 Address L	A7	A6	A5	A4	A3	A2	A1	A0	00000000	RW
9F	1	reserved											
A0	1	IOC <sup>[7]</sup>	Port C (bit addressable)	D7	D6	D5	D4	D3	D2	D1	D0	xxxxxxx	RW
A1	1	INT2CLR <sup>[7]</sup>	Interrupt 2 clear	x	x	x	x	x	x	x	x	xxxxxxx	W
A2	1	INT4CLR <sup>[7]</sup>	Interrupt 4 clear	x	x	x	x	x	x	x	x	xxxxxxx	W
A3	5	reserved											
A8	1	IE	Interrupt Enable (bit addressable)	EA	ES1	ET2	ES0	ET1	EX1	ET0	EX0	00000000	RW
A9	1	reserved											
AA	1	EP2468STAT <sup>[7]</sup>	Endpoint 2,4,6,8 status flags	EP8F	EP8E	EP6F	EP6E	EP4F	EP4E	EP2F	EP2E	01011010	R
AB	1	EP24FIFOFLGS <sup>[7]</sup>	Endpoint 2,4 slave FIFO status flags	0	EP4PF	EP4EF	EP4FF	0	EP2PF	EP2EF	EP2FF	00100010	R
AC	1	EP68FIFOFLGS <sup>[7]</sup>	Endpoint 6,8 slave FIFO status flags	0	EP8PF	EP8EF	EP8FF	0	EP6PF	EP6EF	EP6FF	01100110	R
AD	2	reserved											
AF	1	AUTOPTRSETUP <sup>[7]</sup>	Autopointer 1&2 Setup	0	0	0	0	0	APTR2INC	APTR1INC	APTREN	00000110	RW
B0	1	IOD <sup>[7]</sup>	Port D (bit addressable)	D7	D6	D5	D4	D3	D2	D1	D0	xxxxxxx	RW
B1	1	IOE <sup>[7]</sup>	Port E (NOT bit addressable)	D7	D6	D5	D4	D3	D2	D1	D0	xxxxxxx	RW
B2	1	OEA <sup>[7]</sup>	Port A Output Enable	D7	D6	D5	D4	D3	D2	D1	D0	00000000	RW
B3	1	OEB <sup>[7]</sup>	Port B Output Enable	D7	D6	D5	D4	D3	D2	D1	D0	00000000	RW
B4	1	OEC <sup>[7]</sup>	Port C Output Enable	D7	D6	D5	D4	D3	D2	D1	D0	00000000	RW
B5	1	OED <sup>[7]</sup>	Port D Output Enable	D7	D6	D5	D4	D3	D2	D1	D0	00000000	RW
B6	1	OEE <sup>[7]</sup>	Port E Output Enable	D7	D6	D5	D4	D3	D2	D1	D0	00000000	RW
B7	1	reserved											
B8	1	IP	Interrupt Priority (bit addressable)	1	PS1	PT2	PS0	PT1	PX1	PT0	PX0	10000000	RW
B9	1	reserved											
BA	1	EP01STAT <sup>[7]</sup>	Endpoint 0&1 Status	0	0	0	0	0	EP1INBSY	EP1OUTBSY	EP0BSY	00000000	R
BB	1	GPIFTRIG <sup>[7]</sup> [6]	Endpoint 2,4,6,8 GPIF slave FIFO Trigger	DONE	0	0	0	0	RW	EP1	EP0	10000xxx	brrrb
BC	1	reserved											
BD	1	GPIFGLDATH <sup>[7]</sup>	GPIF Data H (16-bit mode only)	D15	D14	D13	D12	D11	D10	D9	D8	xxxxxxx	RW
BE	1	GPIFGLDATLX <sup>[7]</sup>	GPIF Data L w/ Trigger	D7	D6	D5	D4	D3	D2	D1	D0	xxxxxxx	RW
BF	1	GPIFGLDATLNOX <sup>[7]</sup>	GPIF Data L w/ No Trigger	D7	D6	D5	D4	D3	D2	D1	D0	xxxxxxx	R
C0	1	SCON1 <sup>[7]</sup>	Serial Port 1 Control (bit addressable)	SM0_1	SM1_1	SM2_1	REN_1	TB8_1	RB8_1	TL_1	RI_1	00000000	RW
C1	1	SBUF1 <sup>[7]</sup>	Serial Port 1 Data Buffer	D7	D6	D5	D4	D3	D2	D1	D0	00000000	RW
C2	6	reserved											
C8	1	T2CON	Timer/Counter 2 Control (bit addressable)	TF2	EXF2	RCLK	TCLK	EXEN2	TR2	CT2	CPRL2	00000000	RW
C9	1	reserved											
CA	1	RCAP2L	Capture for Timer 2, auto-reload, up-counter	D7	D6	D5	D4	D3	D2	D1	D0	00000000	RW
CB	1	RCAP2H	Capture for Timer 2, auto-reload, up-counter	D7	D6	D5	D4	D3	D2	D1	D0	00000000	RW
CC	1	TL2	Timer 2 reload L	D7	D6	D5	D4	D3	D2	D1	D0	00000000	RW
CD	1	TH2	Timer 2 reload H	D15	D14	D13	D12	D11	D10	D9	D8	00000000	RW
CE	2	reserved											
D0	1	PSW	Program Status Word (bit addressable)	CY	AC	F0	RS1	RS0	OV	F1	P	00000000	RW
D1	7	reserved											
D8	1	EICON <sup>[7]</sup>	External Interrupt Control	SMOD1	1	ERESI	RESI	INT6	0	0	0	01000000	RW
D9	7	reserved											
E0	1	ACC	Accumulator (bit addressable)	D7	D6	D5	D4	D3	D2	D1	D0	00000000	RW
E1	7	reserved											
E8	1	EIE <sup>[7]</sup>	External Interrupt Enable(s)	1	1	1	EX6	EX5	EX4	EiPC	EUSB	11100000	RW
E9	7	reserved											
F0	1	B	B (bit addressable)	D7	D6	D5	D4	D3	D2	D1	D0	00000000	RW
F1	7	reserved											
F8	1	EIP <sup>[7]</sup>	External Interrupt Priority Control	1	1	1	PX6	PX5	PX4	PiPC	PUSB	11100000	RW
F9	7	reserved											

R = all bits read-only  
 W = all bits write-only  
 r = read-only bit  
 w = write-only bit  
 b = both read/write bit

## 6.0 Absolute Maximum Ratings

Storage Temperature .....	-65°C to +150°C
Ambient Temperature with Power Supplied .....	0°C to +70°C
Supply Voltage to Ground Potential .....	-0.5V to +4.0V
DC Input Voltage to Any Input Pin .....	5.25V
DC Voltage Applied to Outputs in High Z State.....	-0.5V to VCC + 0.5V
Power Dissipation .....	936 mW
Static Discharge Voltage .....	>2000V
Max Output Current, per I/O port .....	10 mA
Max Output Current, all five I/O ports (128- and 100-pin packages) .....	50 mA

## 7.0 Operating Conditions

T <sub>A</sub> (Ambient Temperature Under Bias) .....	0°C to +70°C
Supply Voltage .....	+3.0V to +3.6V
Ground Voltage .....	0V
F <sub>OSC</sub> (Oscillator or Crystal Frequency) .....	24 MHz ± 100 ppm Parallel Resonant

## 8.0 DC Characteristics

**Table 8-1. DC Characteristics**

Parameter	Description	Conditions	Min.	Typ.	Max.	Unit
V <sub>CC</sub>	Supply Voltage		3.0	3.3	3.6	V
V <sub>IH</sub>	Input HIGH Voltage		2		5.25	V
V <sub>IL</sub>	Input LOW Voltage		-0.5		0.8	V
I <sub>I</sub>	Input Leakage Current	0 < V <sub>IN</sub> < V <sub>CC</sub>			±10	μA
V <sub>OH</sub>	Output Voltage HIGH	I <sub>OUT</sub> = 4 mA	2.4			V
V <sub>OL</sub>	Output LOW Voltage	I <sub>OUT</sub> = -4 mA			0.4	V
I <sub>OH</sub>	Output Current HIGH				4	mA
I <sub>OL</sub>	Output Current LOW				4	mA
C <sub>IN</sub>	Input Pin Capacitance	Except D+/D-			10	pF
		D+/D-			15	pF
I <sub>SUSP</sub>	Suspend Current	Connected		250	400	μA
		Disconnected		30	180	μA
I <sub>CC</sub>	Supply Current	8051 running, connected to USB HS		200	260	mA
		8051 running, connected to USB FS		90	150	mA
T <sub>RESET</sub>	Reset Time after valid power	V <sub>CC</sub> min. = 3.0V	1.91			ms

### 8.1 USB Transceiver

USB 2.0-certified in full- and high-speed modes.

**Note:**

9. Connected to the USB includes 1.5k-ohm internal pull-up. Disconnected has the 1.5k-ohm internal pull-up excluded.



## 9.0 AC Electrical Characteristics

### 9.1 USB Transceiver

USB 2.0-certified in full- and high-speed modes.

### 9.2 Program Memory Read

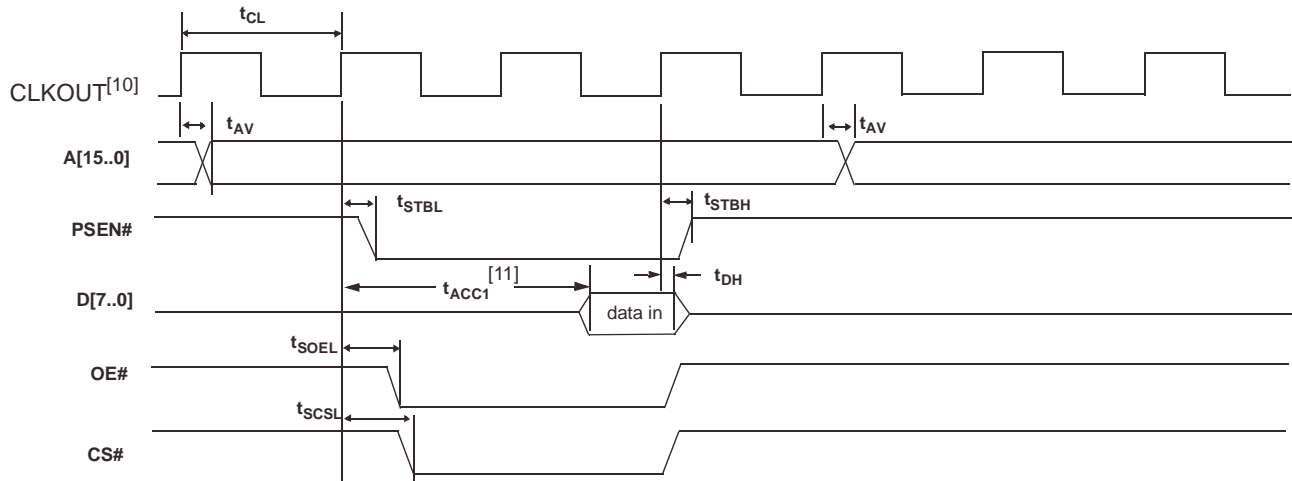


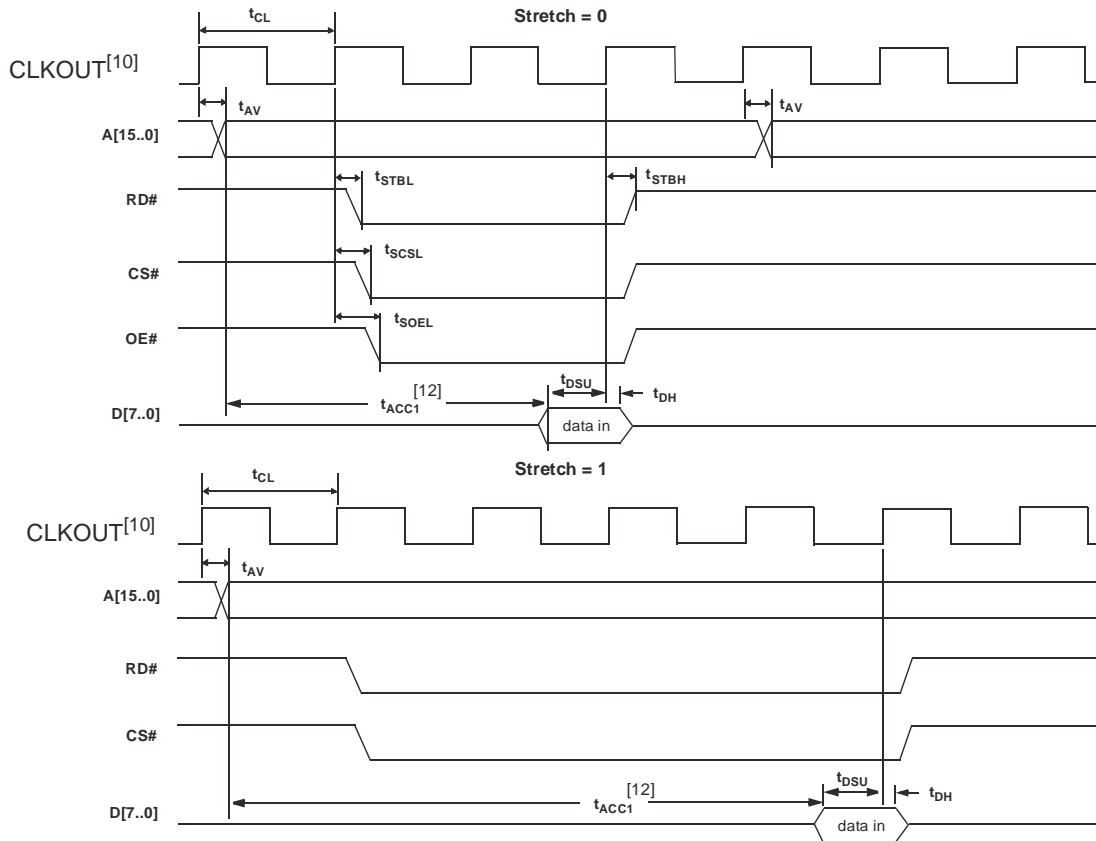
Figure 9-1. Program Memory Read Timing Diagram

Table 9-1. Program Memory Read Parameters

Parameter	Description	Min.	Typ.	Max.	Unit	Notes
$t_{CL}$	1/CLKOUT Frequency		20.83		ns	48 MHz
			41.66		ns	24 MHz
			83.2		ns	12 MHz
$t_{AV}$	Delay from Clock to Valid Address	0		10.7	ns	
$t_{STBL}$	Clock to PSEN Low	0		8	ns	
$t_{STBH}$	Clock to PSEN High	0		8	ns	
$t_{SOEL}$	Clock to OE Low			11.1	ns	
$t_{SCSL}$	Clock to CS Low			13	ns	
$t_{DSU}$	Data Set-up to Clock	9.6			ns	
$t_{DH}$	Data Hold Time	0			ns	

**Notes:**

10. CLKOUT is shown with positive polarity.
11.  $t_{ACC1}$  is computed from the above parameters as follows:  
 $t_{ACC1}(24\text{ MHz}) = 3 \cdot t_{CL} - t_{AV} - t_{DSU} = 106\text{ ns}$   
 $t_{ACC1}(48\text{ MHz}) = 3 \cdot t_{CL} - t_{AV} - t_{DSU} = 43\text{ ns}$

**9.3 Data Memory Read**

**Figure 9-2. Data Memory Read Timing Diagram**

Parameter	Description	Min.	Typ.	Max.	Unit	Notes
$t_{CL}$	1/CLKOUT Frequency		20.83		ns	48 MHz
			41.66		ns	24 MHz
			83.2		ns	12 MHz
$t_{AV}$	Delay from Clock to Valid Address			10.7	ns	
$t_{STBL}$	Clock to RD LOW			11	ns	
$t_{STBH}$	Clock to RD HIGH			11	ns	
$t_{SCSL}$	Clock to CS LOW			13	ns	
$t_{SOEL}$	Clock to OE LOW			11.1	ns	
$t_{DSU}$	Data Set-up to Clock	9.6			ns	
$t_{DH}$	Data Hold Time	0			ns	

When using the AUTPOPTR1 or AUTOPTTR2 to address external memory, the address of AUTOPTTR1 will only be active while either RD# or WR# are active. The address of AUTOPTTR2 will be active throughout the cycle and meet the above address valid time for which is based on the stretch value.

**Note:**

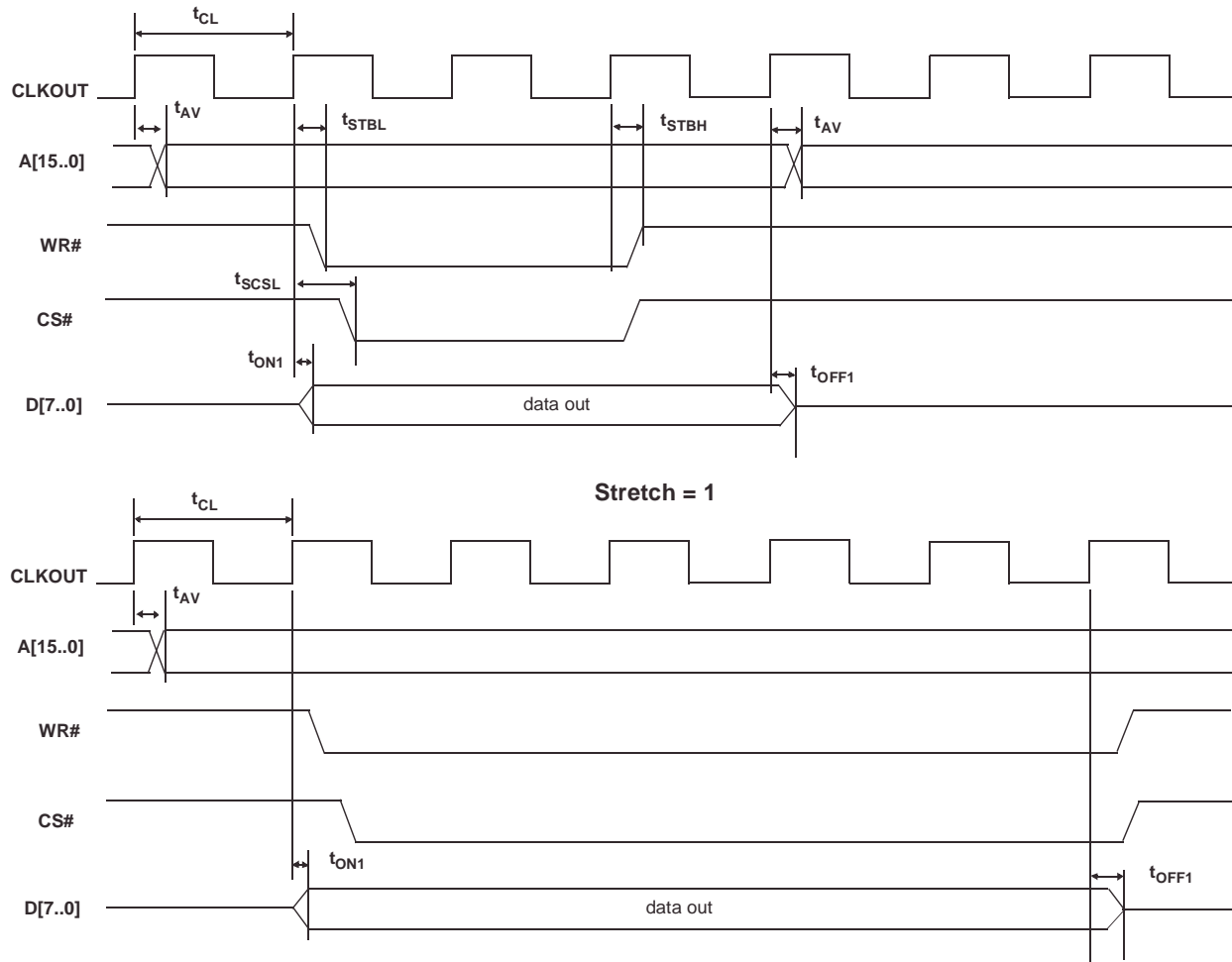
12.  $t_{ACC2}$  and  $t_{ACC3}$  are computed from the above parameters as follows:

$$t_{ACC2}(24 \text{ MHz}) = 3 \cdot t_{CL} - t_{AV} - t_{DSU} = 106 \text{ ns}$$

$$t_{ACC2}(48 \text{ MHz}) = 3 \cdot t_{CL} - t_{AV} - t_{DSU} = 43 \text{ ns}$$

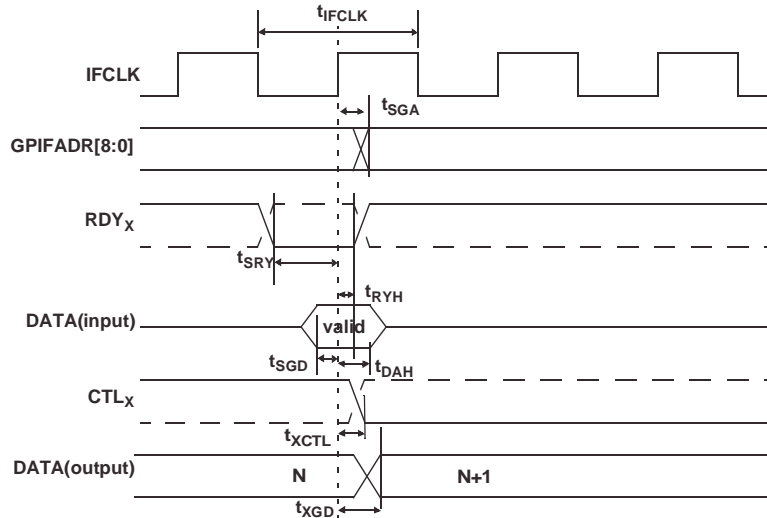
$$t_{ACC3}(24 \text{ MHz}) = 5 \cdot t_{CL} - t_{AV} - t_{DSU} = 190 \text{ ns}$$

$$t_{ACC3}(48 \text{ MHz}) = 5 \cdot t_{CL} - t_{AV} - t_{DSU} = 86 \text{ ns.}$$

**9.4 Data Memory Write**

**Figure 9-3. Data Memory Write Timing Diagram**
**Table 9-2. Data Memory Write Parameters**

Parameter	Description	Min.	Max.	Unit	Notes
$t_{AV}$	Delay from Clock to Valid Address	0	10.7	ns	
$t_{STBL}$	Clock to WR Pulse LOW	0	11.2	ns	
$t_{STBH}$	Clock to WR Pulse HIGH	0	11.2	ns	
$t_{SCSL}$	Clock to CS Pulse LOW		13.0	ns	
$t_{ON1}$	Clock to Data Turn-on	0	13.1	ns	
$t_{OFF1}$	Clock to Data Hold Time	0	13.1	ns	

When using the AUTPOPTR1 or AUTOPTR2 to address external memory, the address of AUTOPTR1 will only be active while either RD# or WR# are active. The address of AUTOPTR2 will be active throughout the cycle and meet the above address valid time for which is based on the stretch value.

**9.5 GPIF Synchronous Signals**

**Figure 9-4. GPIF Synchronous Signals Timing Diagram<sup>[13]</sup>**
**Table 9-3. GPIF Synchronous Signals Parameters with Internally Sourced IFCLK<sup>[14, 15]</sup>**

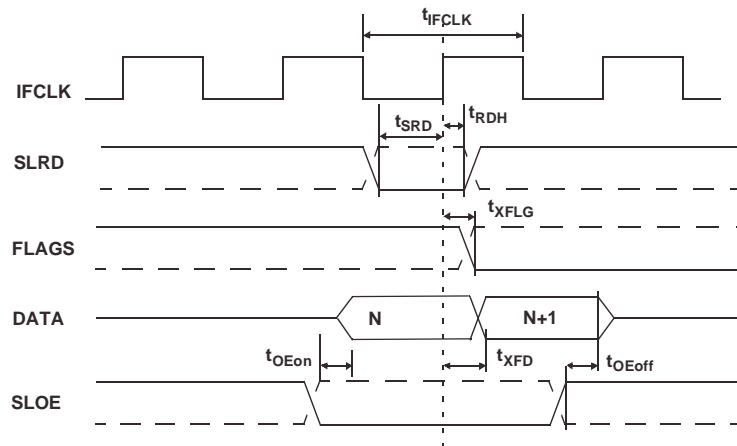
Parameter	Description	Min.	Max.	Unit
$t_{IFCLK}$	IFCLK Period	20.83		ns
$t_{SRY}$	RDY <sub>x</sub> to Clock Set-up Time	8.9		ns
$t_{RYH}$	Clock to RDY <sub>x</sub>	0		ns
$t_{SGD}$	GPIF Data to Clock Set-up Time	9.2		ns
$t_{DAH}$	GPIF Data Hold Time	0		ns
$t_{SGA}$	Clock to GPIF Address Propagation Delay		7.5	ns
$t_{XGD}$	Clock to GPIF Data Output Propagation Delay		11	ns
$t_{XCTL}$	Clock to CTL <sub>x</sub> Output Propagation Delay		6.7	ns

**Table 9-4. GPIF Synchronous Signals Parameters with Externally Sourced IFCLK<sup>[15]</sup>**

Parameter	Description	Min.	Max.	Unit
$t_{IFCLK}$	IFCLK Period	20.83	200	ns
$t_{SRY}$	RDY <sub>x</sub> to Clock Set-up Time	2.9		ns
$t_{RYH}$	Clock to RDY <sub>x</sub>	3.7		ns
$t_{SGD}$	GPIF Data to Clock Set-up Time	3.2		ns
$t_{DAH}$	GPIF Data Hold Time	4.5		ns
$t_{SGA}$	Clock to GPIF Address Propagation Delay		11.5	ns
$t_{XGD}$	Clock to GPIF Data Output Propagation Delay		15	ns
$t_{XCTL}$	Clock to CTL <sub>x</sub> Output Propagation Delay		10.7	ns

**Notes:**

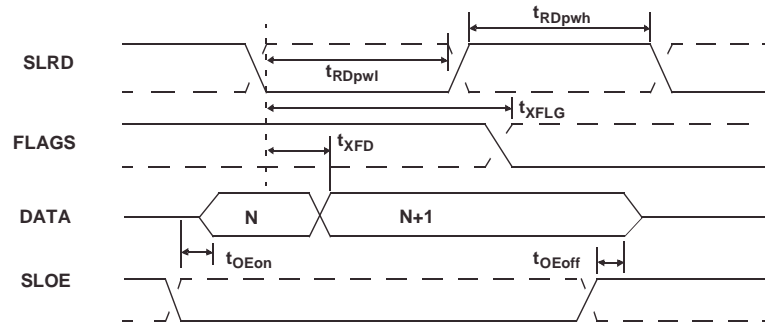
13. Dashed lines denote signals with programmable polarity.
14. GPIF asynchronous RDY<sub>x</sub> signals have a minimum set-up time of 50 ns when using internal 48-MHz IFCLK.
15. IFCLK must not exceed 48 MHz.

**9.6 Slave FIFO Synchronous Read**

**Figure 9-5. Slave FIFO Synchronous Read Timing Diagram<sup>[13]</sup>**
**Table 9-5. Slave FIFO Synchronous Read Parameters with Internally Sourced IFCLK<sup>[15]</sup>**

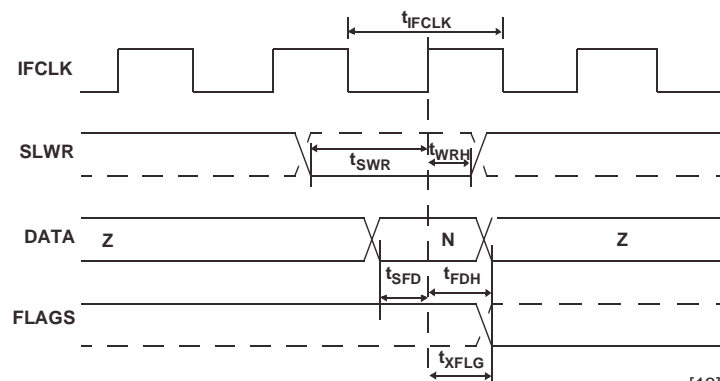
Parameter	Description	Min.	Max.	Unit
$t_{IFCLK}$	IFCLK Period	20.83		ns
$t_{SRD}$	SLRD to Clock Set-up Time	18.7		ns
$t_{RDH}$	Clock to SLRD Hold Time	0		ns
$t_{OEon}$	SLOE Turn-on to FIFO Data Valid		10.5	ns
$t_{OEoff}$	SLOE Turn-off to FIFO Data Hold		10.5	ns
$t_{XFLG}$	Clock to FLAGS Output Propagation Delay		9.5	ns
$t_{XFD}$	Clock to FIFO Data Output Propagation Delay		11	ns

**Table 9-6. Slave FIFO Synchronous Read Parameters with Externally Sourced IFCLK<sup>[15]</sup>**

Parameter	Description	Min.	Max.	Unit
$t_{IFCLK}$	IFCLK Period	20.83	200	ns
$t_{SRD}$	SLRD to Clock Set-up Time	12.7		ns
$t_{RDH}$	Clock to SLRD Hold Time	3.7		ns
$t_{OEon}$	SLOE Turn-on to FIFO Data Valid		10.5	ns
$t_{OEoff}$	SLOE Turn-off to FIFO Data Hold		10.5	ns
$t_{XFLG}$	Clock to FLAGS Output Propagation Delay		13.5	ns
$t_{XFD}$	Clock to FIFO Data Output Propagation Delay		15	ns

**9.7 Slave FIFO Asynchronous Read**

**Figure 9-6. Slave FIFO Asynchronous Read Timing Diagram<sup>[13]</sup>**
**Table 9-7. Slave FIFO Asynchronous Read Parameters<sup>[16]</sup>**

Parameter	Description	Min.	Max.	Unit
$t_{RDpwl}$	SLRD Pulse Width LOW	50		ns
$t_{RDpwh}$	SLRD Pulse Width HIGH	50		ns
$t_{XFLG}$	SLRD to FLAGS Output Propagation Delay		70	ns
$t_{XFD}$	SLRD to FIFO Data Output Propagation Delay		15	ns
$t_{OEon}$	SLOE Turn-on to FIFO Data Valid		10.5	ns
$t_{OEoff}$	SLOE Turn-off to FIFO Data Hold		10.5	ns

**9.8 Slave FIFO Synchronous Write**

**Figure 9-7. Slave FIFO Synchronous Write Timing Diagram<sup>[13]</sup>**
**Table 9-8. Slave FIFO Synchronous Write Parameters with Internally Sourced IFCLK<sup>[15]</sup>**

Parameter	Description	Min.	Max.	Unit
$t_{IFCLK}$	IFCLK Period	20.83		ns
$t_{SWR}$	SLWR to Clock Set-up Time	18.1		ns
$t_{WRH}$	Clock to SLWR Hold Time	0		ns
$t_{SFD}$	FIFO Data to Clock Set-up Time	9.2		ns
$t_{FDH}$	Clock to FIFO Data Hold Time	0		ns
$t_{XFLG}$	Clock to FLAGS Output Propagation Time		9.5	ns

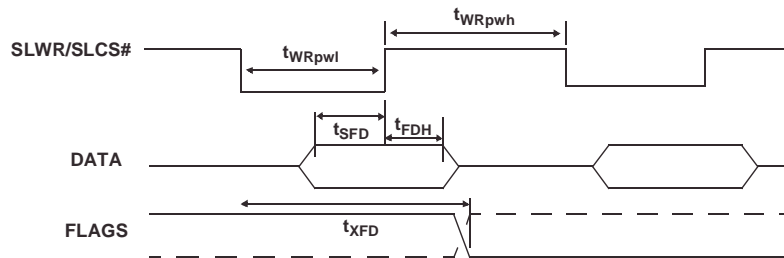
**Note:**

16. Slave FIFO asynchronous parameter values use internal IFCLK setting at 48 MHz.

**Table 9-9. Slave FIFO Synchronous Write Parameters with Externally Sourced IFCLK<sup>[15]</sup>**

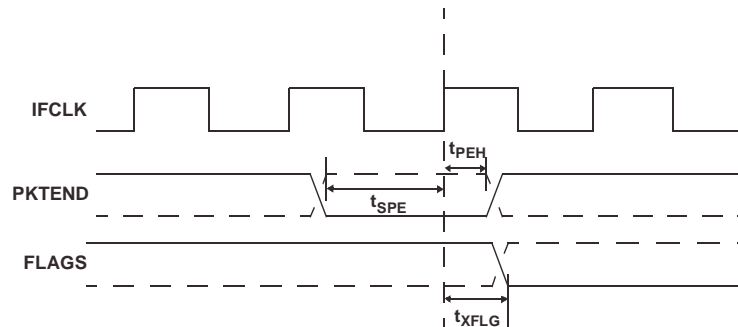
Parameter	Description	Min.	Max.	Unit
$t_{IFCLK}$	IFCLK Period	20.83	200	ns
$t_{SWR}$	SLWR to Clock Set-up Time	12.1		ns
$t_{WRH}$	Clock to SLWR Hold Time	3.6		ns
$t_{SFD}$	FIFO Data to Clock Set-up Time	3.2		ns
$t_{FDH}$	Clock to FIFO Data Hold Time	4.5		ns
$t_{XFLG}$	Clock to FLAGS Output Propagation Time		13.5	ns

### 9.9 Slave FIFO Asynchronous Write


**Figure 9-8. Slave FIFO Asynchronous Write Timing Diagram<sup>[13]</sup>**
**Table 9-10. Slave FIFO Asynchronous Write Parameters with Internally Sourced IFCLK<sup>[16]</sup>**

Parameter	Description	Min.	Max.	Unit
$t_{WRpwl}$	SLWR Pulse LOW	50		ns
$t_{WRpwh}$	SLWR Pulse HIGH	70		ns
$t_{SFD}$	SLWR to FIFO DATA Set-up Time	10		ns
$t_{FDH}$	FIFO DATA to SLWR Hold Time	10		ns
$t_{XFD}$	SLWR to FLAGS Output Propagation Delay		70	ns

### 9.10 Slave FIFO Synchronous Packet End Strobe


**Figure 9-9. Slave FIFO Synchronous Packet End Strobe Timing Diagram<sup>[13]</sup>**
**Table 9-11. Slave FIFO Synchronous Packet End Strobe Parameters with Internally Sourced IFCLK<sup>[15]</sup>**

Parameter	Description	Min.	Max.	Unit
$t_{IFCLK}$	IFCLK Period	20.83		ns
$t_{SPE}$	PKTEND to Clock Set-up Time	14.6		ns
$t_{PEH}$	Clock to PKTEND Hold Time	0		ns
$t_{XFLG}$	Clock to FLAGS Output Propagation Delay		9.5	ns



**Table 9-12. Slave FIFO Synchronous Packet End Strobe Parameters with Externally Sourced IFCLK <sup>[15]</sup>**

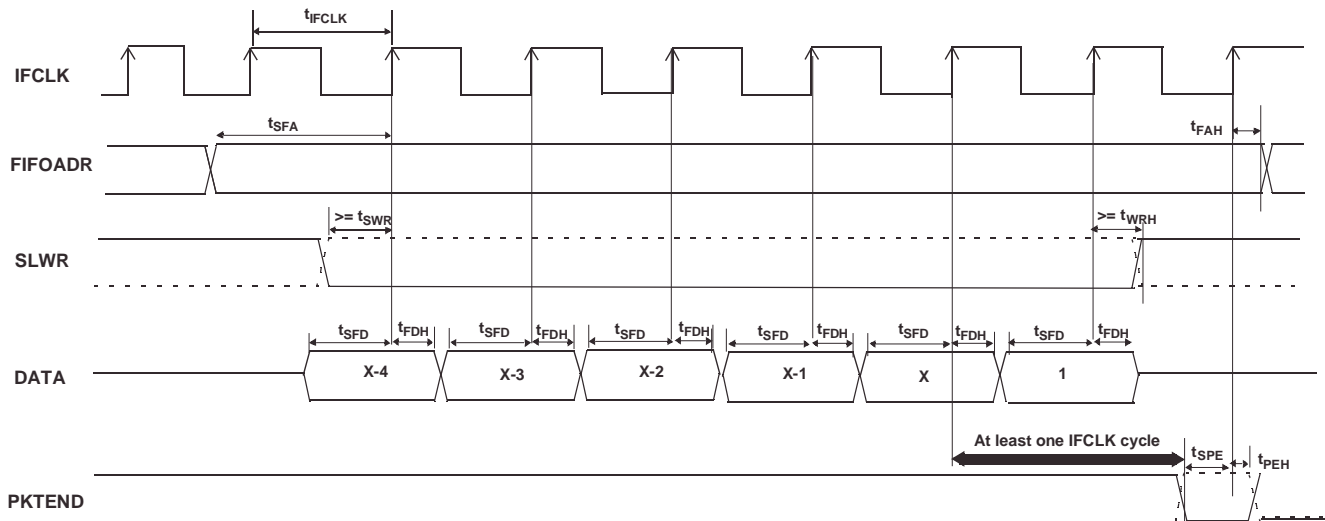
Parameter	Description	Min.	Max.	Unit
$t_{IFCLK}$	IFCLK Period	20.83	200	ns
$t_{SPE}$	PKTEND to Clock Set-up Time	8.6		ns
$t_{PEH}$	Clock to PKTEND Hold Time	2.5		ns
$t_{XFLG}$	Clock to FLAGS Output Propagation Delay		13.5	ns

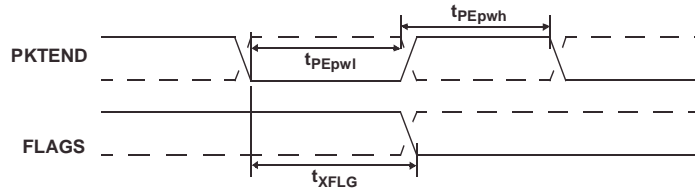
There is no specific timing requirement that needs to be met for asserting PKTEND pin with regards to asserting SLWR. PKTEND can be asserted with the last data value clocked into the FIFOs or thereafter. The only consideration is the set-up time  $t_{SPE}$  and the hold time  $t_{PEH}$  must be met.

Although there are no specific timing requirement for the PKTEND assertion, there is a specific corner case condition that needs attention while using the PKTEND to commit a one byte/word packet. There is an additional timing requirement that need to be met when the FIFO is configured to operate in auto mode and it is desired to send two packets back to back: a full packet (full defined as the number of bytes in the FIFO meeting the level set in AUTOINLEN register) committed automatically followed by a short one byte/word packet committed manually using the PKTEND pin. In this particular scenario, user must make sure to assert PKTEND at least one

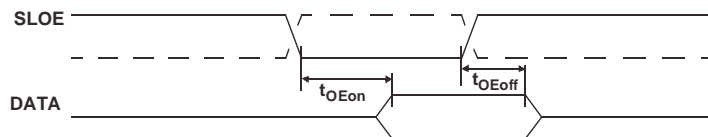
clock cycle after the rising edge that caused the last byte/word to be clocked into the previous auto committed packet. *Figure 9-10* below shows this scenario. X is the value the AUTOINLEN register is set to when the IN endpoint is configured to be in auto mode.

*Figure 9-10* shows a scenario where two packets are being committed. The first packet gets committed automatically when the number of bytes in the FIFO reaches X (value set in AUTOINLEN register) and the second one byte/word short packet being committed manually using PKTEND. Note that there is at least one IFCLK cycle timing between the assertion of PKTEND and clocking of the last byte of the previous packet (causing the packet to be committed automatically). Failing to adhere to this timing, will result in the FX2 failing to send the one byte/word short packet.

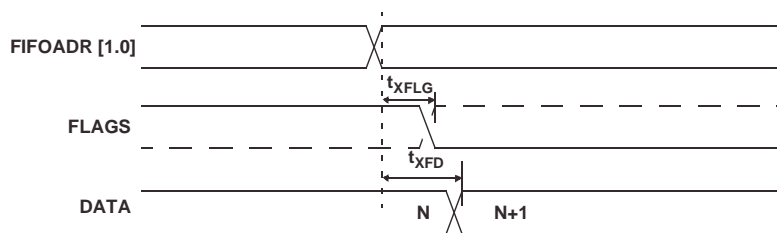

**Figure 9-10. Slave FIFO Synchronous Write Sequence and Timing Diagram**

**9.11 Slave FIFO Asynchronous Packet End Strobe**

**Figure 9-11. Slave FIFO Asynchronous Packet End Strobe Timing Diagram<sup>[13]</sup>**
**Table 9-13. Slave FIFO Asynchronous Packet End Strobe Parameters<sup>[16]</sup>**

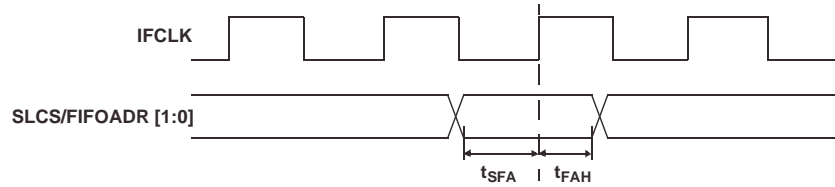
Parameter	Description	Min.	Max.	Unit
$t_{PEpwl}$	PKTEND Pulse Width LOW	50		ns
$t_{PWpwh}$	PKTEND Pulse Width HIGH	50		ns
$t_{XFLG}$	PKTEND to FLAGS Output Propagation Delay		115	ns

**9.12 Slave FIFO Output Enable**

**Figure 9-12. Slave FIFO Output Enable Timing Diagram<sup>[13]</sup>**
**Table 9-14. Slave FIFO Output Enable Parameters**

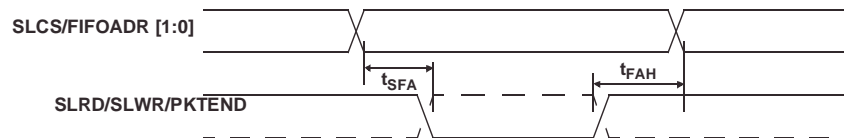
Parameter	Description	Min.	Max.	Unit
$t_{OEon}$	SLOE Assert to FIFO DATA Output		10.5	ns
$t_{OEoff}$	SLOE Deassert to FIFO DATA Hold		10.5	ns

**9.13 Slave FIFO Address to Flags/Data**

**Figure 9-13. Slave FIFO Address to Flags/Data Timing Diagram<sup>[13]</sup>**
**Table 9-15. Slave FIFO Address to Flags/Data Parameters**

Parameter	Description	Min.	Max.	Unit
$t_{XFLG}$	FIFOADR[1:0] to FLAGS Output Propagation Delay		10.7	ns
$t_{XFD}$	FIFOADR[1:0] to FIFODATA Output Propagation Delay		14.3	ns

**9.14 Slave FIFO Synchronous Address**

**Figure 9-14. Slave FIFO Synchronous Address Timing Diagram**
**Table 9-16. Slave FIFO Synchronous Address Parameters<sup>[15]</sup>**

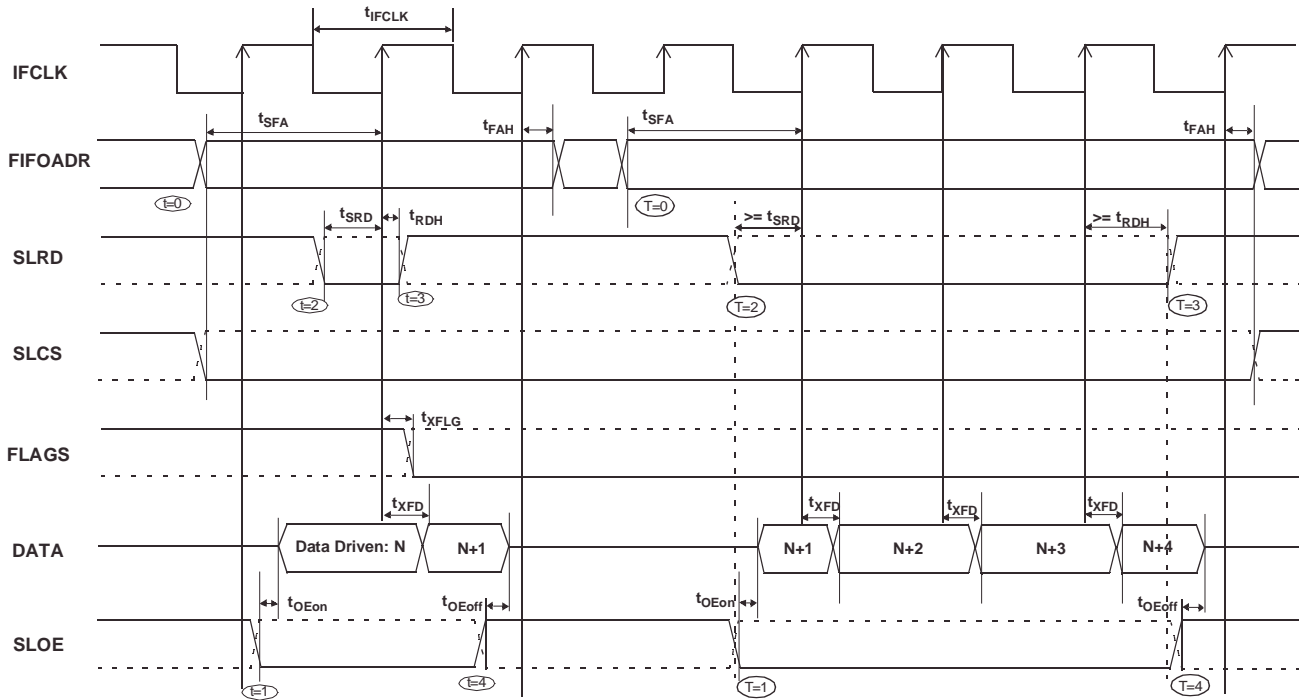
Parameter	Description	Min.	Max.	Unit
$t_{IFCLK}$	Interface Clock Period	20.83	200	ns
$t_{SFA}$	FIFOADR[1:0] to Clock Set-up Time	25		ns
$t_{FAH}$	Clock to FIFOADR[1:0] Hold Time	10		ns

**9.15 Slave FIFO Asynchronous Address**

**Figure 9-15. Slave FIFO Asynchronous Address Timing Diagram<sup>[13]</sup>**
**Table 9-17. Slave FIFO Asynchronous Address Parameters<sup>[16]</sup>**

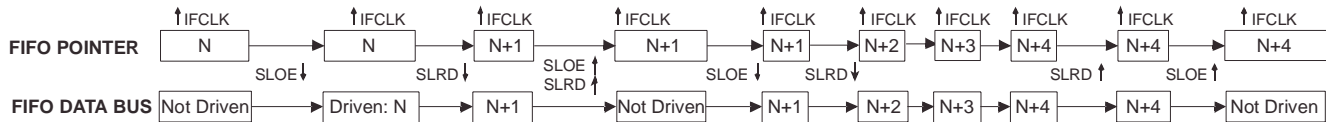
Parameter	Description	Min.	Max.	Unit
$t_{SFA}$	FIFOADR[1:0] to RD/WR/PKTEND Set-up Time	10		ns
$t_{FAH}$	SLRD/PKTEND to FIFOADR[1:0] Hold Time	20		ns
$t_{FAH}$	SLWR/PKTEND to FIFOADR[1:0] Hold Time	70		ns

## 9.16 Sequence Diagram

### 9.16.1 Single and Burst Synchronous Read Example



**Figure 9-16. Slave FIFO Synchronous Read Sequence and Timing Diagram**



**Figure 9-17. Slave FIFO Synchronous Sequence of Events Diagram**

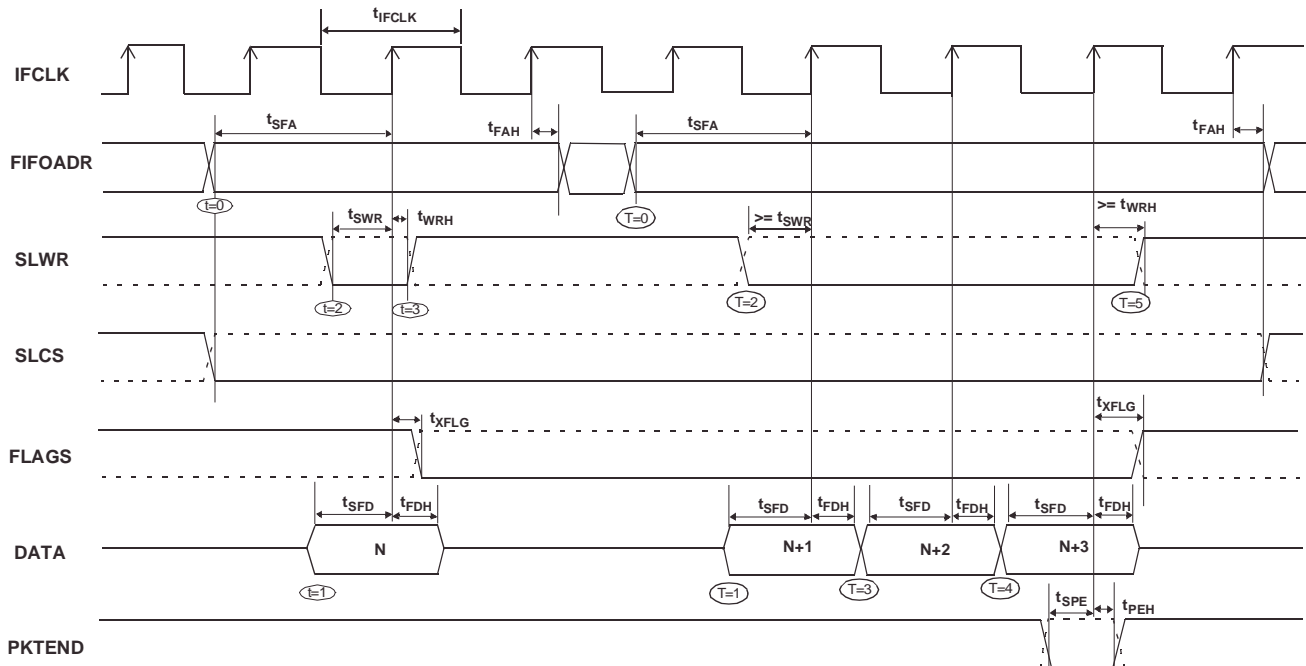
Figure 9-16 shows the timing relationship of the SLAVE FIFO signals during a synchronous FIFO read using IFCLK as the synchronizing clock. The diagram illustrates a single read followed by a burst read.

- At  $t = 0$  the FIFO address is stable and the signal SLCS is asserted (SLCS may be tied low in some applications). Note:  $t_{SFA}$  has a minimum of 25 ns. This means when IFCLK is running at 48 MHz, the FIFO address set-up time is more than one IFCLK cycle.
- At  $t = 1$ , SLOE is asserted. SLOE is an output enable only, whose sole function is to drive the data bus. The data that is driven on the bus is the data that the internal FIFO pointer is currently pointing to. In this example it is the first data value in the FIFO. Note: the data is pre-fetched and is driven on the bus when SLOE is asserted.
- At  $t = 2$ , SLRD is asserted. SLRD must meet the setup time of  $t_{SRD}$  (time from asserting the SLRD signal to the rising edge of the IFCLK) and maintain a minimum hold time of  $t_{RDH}$  (time from the IFCLK edge to the de-assertion of the SLRD signal). If the SLCS signal is used, it must be asserted

with SLRD, or before SLRD is asserted (i.e. the SLCS and SLRD signals must both be asserted to start a valid read condition).

- The FIFO pointer is updated on the rising edge of the IFCLK, while SLRD is asserted. This starts the propagation of data from the newly addressed location to the data bus. After a propagation delay of  $t_{XFD}$  (measured from the rising edge of IFCLK) the new data value is present. N is the first data value read from the FIFO. In order to have data on the FIFO data bus, SLOE MUST also be asserted.

The same sequence of events are shown for a burst read and are marked with the time indicators of  $T = 0$  through 5. **Note:** For the burst mode, the SLRD and SLOE are left asserted during the entire duration of the read. In the burst read mode, when SLOE is asserted, data indexed by the FIFO pointer is on the data bus. During the first read cycle, on the rising edge of the clock the FIFO pointer is updated and increments to point to address N+1. For each subsequent rising edge of IFCLK, while the SLRD is asserted, the FIFO pointer is incremented and the next data value is placed on the data bus.

**9.16.2 Single and Burst Synchronous Write**


**Figure 9-18. Slave FIFO Synchronous Write Sequence and Timing Diagram**<sup>[13]</sup>

The *Figure 9-18* shows the timing relationship of the SLAVE FIFO signals during a synchronous write using IFCLK as the synchronizing clock. The diagram illustrates a single write followed by burst write of three bytes and committing all four bytes as a short packet using the PKTEND pin.

- At  $t = 0$  the FIFO address is stable and the signal SLCS is asserted. (SLCS may be tied low in some applications)  
Note:  $t_{SFA}$  has a minimum of 25 ns. This means when IFCLK is running at 48 MHz, the FIFO address setup time is more than one IFCLK cycle.
- At  $t = 1$ , the external master/peripheral must output the data value onto the data bus with a minimum set up time of  $t_{SFD}$  before the rising edge of IFCLK.
- At  $t = 2$ , SLWR is asserted. The SLWR must meet the setup time of  $t_{SWR}$  (time from asserting the SLWR signal to the rising edge of IFCLK) and maintain a minimum hold time of  $t_{WRH}$  (time from the IFCLK edge to the deassertion of the SLWR signal). If SLCS signal is used, it must be asserted with SLWR or before SLWR is asserted. (i.e., the SLCS and SLWR signals must both be asserted to start a valid write condition).
- While the SLWR is asserted, data is written to the FIFO and on the rising edge of the IFCLK, the FIFO pointer is incremented. The FIFO flag will also be updated after a delay of  $t_{XFLG}$  from the rising edge of the clock.

The same sequence of events are also shown for a burst write and are marked with the time indicators of  $T = 0$  through 5. **Note:** For the burst mode, SLWR and SLCS are left asserted for the entire duration of writing all the required data values. In this burst write mode, once the SLWR is asserted, the data on the FIFO data bus is written to the FIFO on every rising edge

of IFCLK. The FIFO pointer is updated on each rising edge of IFCLK. In *Figure 9-18*, once the four bytes are written to the FIFO, SLWR is de-asserted. The short 4-byte packet can be committed to the host by asserting the PKTEND signal.

There is no specific timing requirement that needs to be met for asserting PKTEND signal with regards to asserting the SLWR signal. PKTEND can be asserted with the last data value or thereafter. The only requirement is that the set-up time  $t_{SPE}$  and the hold time  $t_{PEH}$  must be met. In the scenario of *Figure 9-18*, the number of data values committed includes the last value written to the FIFO. In this example, both the data value and the PKTEND signal are clocked on the same rising edge of IFCLK. PKTEND can also be asserted in subsequent clock cycles. The FIFOADDR lines should be held constant during the PKTEND assertion.

Although there is no specific timing requirement for the PKTEND assertion, there is a specific corner case condition that needs attention while using the PKTEND to commit a one byte/word packet. Additional timing requirements exist when the FIFO is configured to operate in auto mode and it is desired to send two packets: a full packet (full defined as the number of bytes in the FIFO meeting the level set in AUTOINLEN register) committed automatically followed by a short one byte/word packet committed manually using the PKTEND pin. In this case, the external master must make sure to assert the PKTEND pin at least one clock cycle after the rising edge that caused the last byte/word to be clocked into the previous auto committed packet (the packet with the number of bytes equal to what is set in the AUTOINLEN register). Refer to *Figure 9-10* for further details on this timing.

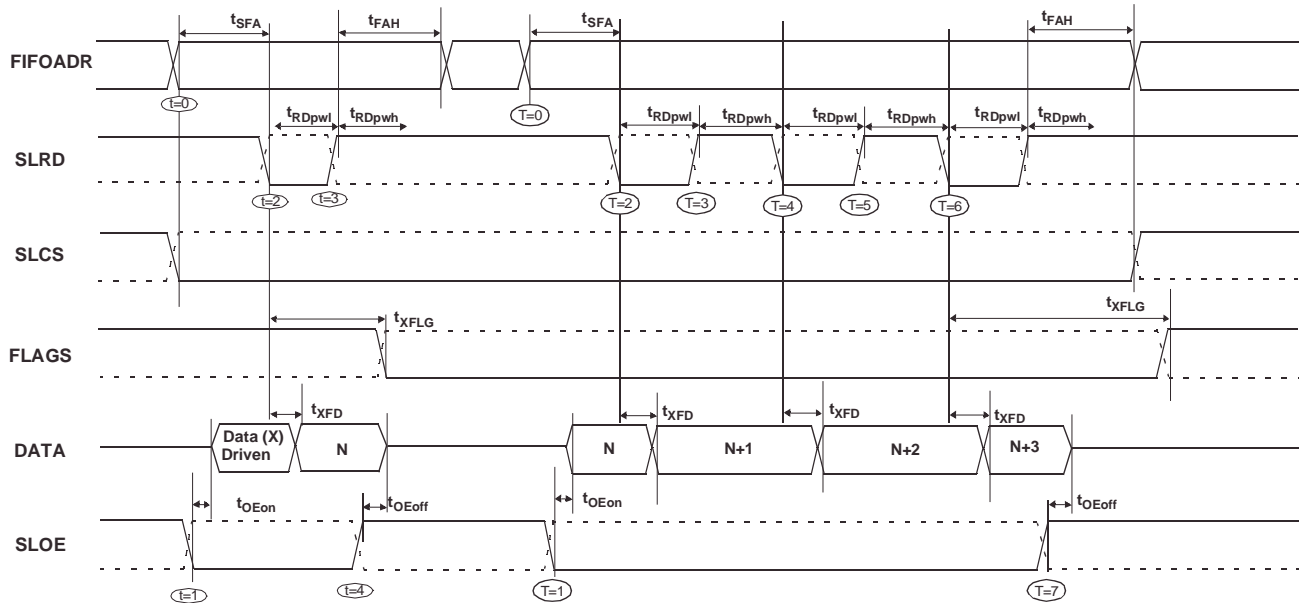
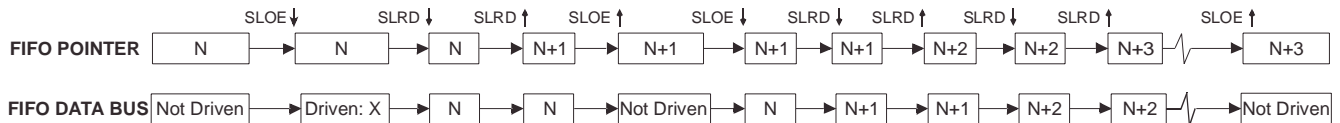
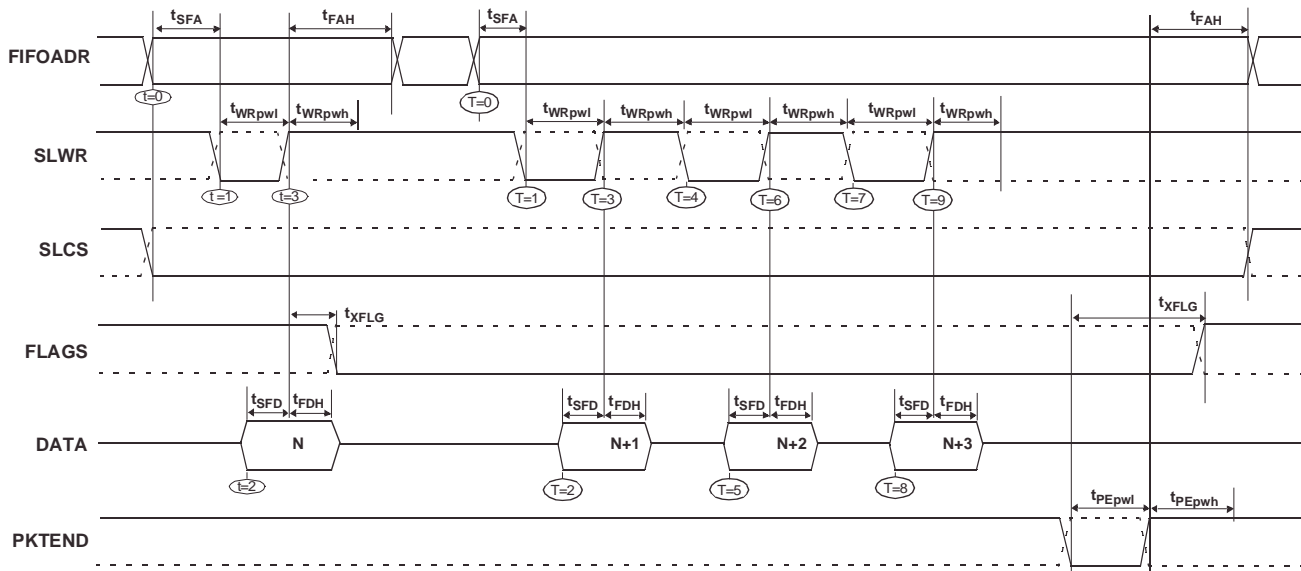
**9.16.3 Sequence Diagram of a Single and Burst Asynchronous Read**

**Figure 9-19. Slave FIFO Asynchronous Read Sequence and Timing Diagram**

**Figure 9-20. Slave FIFO Asynchronous Read Sequence of Events Diagram**

Figure 9-19 diagrams the timing relationship of the SLAVE FIFO signals during an asynchronous FIFO read. It shows a single read followed by a burst read.

- At  $t = 0$  the FIFO address is stable and the SLCS signal is asserted.
- At  $t = 1$ , SLOE is asserted. This results in the data bus being driven. The data that is driven on to the bus is previous data, it data that was in the FIFO from a prior read cycle.
- At  $t = 2$ , SLRD is asserted. The SLRD must meet the minimum active pulse of  $t_{RDpwl}$  and minimum de-active pulse width of  $t_{RDpwh}$ . If SLCS is used then, SLCS must be in asserted with SLRD or before SLRD is asserted (i.e., the SLCS and SLRD signals must both be asserted to start a valid read condition).

- The data that will be driven, after asserting SLRD, is the updated data from the FIFO. This data is valid after a propagation delay of  $t_{XFD}$  from the activating edge of SLRD. In Figure 9-19, data N is the first valid data read from the FIFO. For data to appear on the data bus during the read cycle (i.e., SLRD is asserted), SLOE MUST be in an asserted state. SLRD and SLOE can also be tied together.

The same sequence of events is also shown for a burst read marked with  $T = 0$  through 5. **Note:** In burst read mode, during SLOE is assertion, the data bus is in a driven state and outputs the previous data. Once SLRD is asserted, the data from the FIFO is driven on the data bus (SLOE must also be asserted) and then the FIFO pointer is incremented.

**9.16.4 Sequence Diagram of a Single and Burst Asynchronous Write**


**Figure 9-21. Slave FIFO Asynchronous Write Sequence and Timing Diagram<sup>[13]</sup>**

Figure 9-21 diagrams the timing relationship of the SLAVE FIFO write in an asynchronous mode. The diagram shows a single write followed by a burst write of three bytes and committing the 4-byte-short packet using PKTEND.

- At  $t = 0$  the FIFO address is applied, insuring that it meets the setup time of  $t_{SFA}$ . If SLCS is used, it must also be asserted (SLCS may be tied low in some applications).
- At  $t = 1$  SLWR is asserted. SLWR must meet the minimum active pulse of  $t_{WRpwl}$  and minimum de-active pulse width of  $t_{WRpwh}$ . If the SLCS is used, it must be in asserted with SLWR or before SLWR is asserted.
- At  $t = 2$ , data must be present on the bus  $t_{SFD}$  before the deasserting edge of SLWR.
- At  $t = 3$ , deasserting SLWR will cause the data to be written from the data bus to the FIFO and then increments the FIFO pointer. The FIFO flag is also updated after  $t_{XFLG}$  from the deasserting edge of SLWR.

The same sequence of events is shown for a burst write and is indicated by the timing marks of T = 0 through 5. **Note:** In the burst write mode, once SLWR is deasserted, the data is written to the FIFO and then the FIFO pointer is incremented to the next byte in the FIFO.

In Figure 9-21 once the four bytes are written to the FIFO and SLWR is deasserted, the short 4-byte packet can be committed to the host using the PKTEND. The external device should be designed to not assert SLWR and the PKTEND signal at the same time. It should be designed to assert the PKTEND after SLWR is deasserted and met the minimum deasserted pulse width. The FIFOADDR lines are to be held constant during the PKTEND assertion.

## 10.0 Ordering Information

**Table 10-1. Ordering Information**

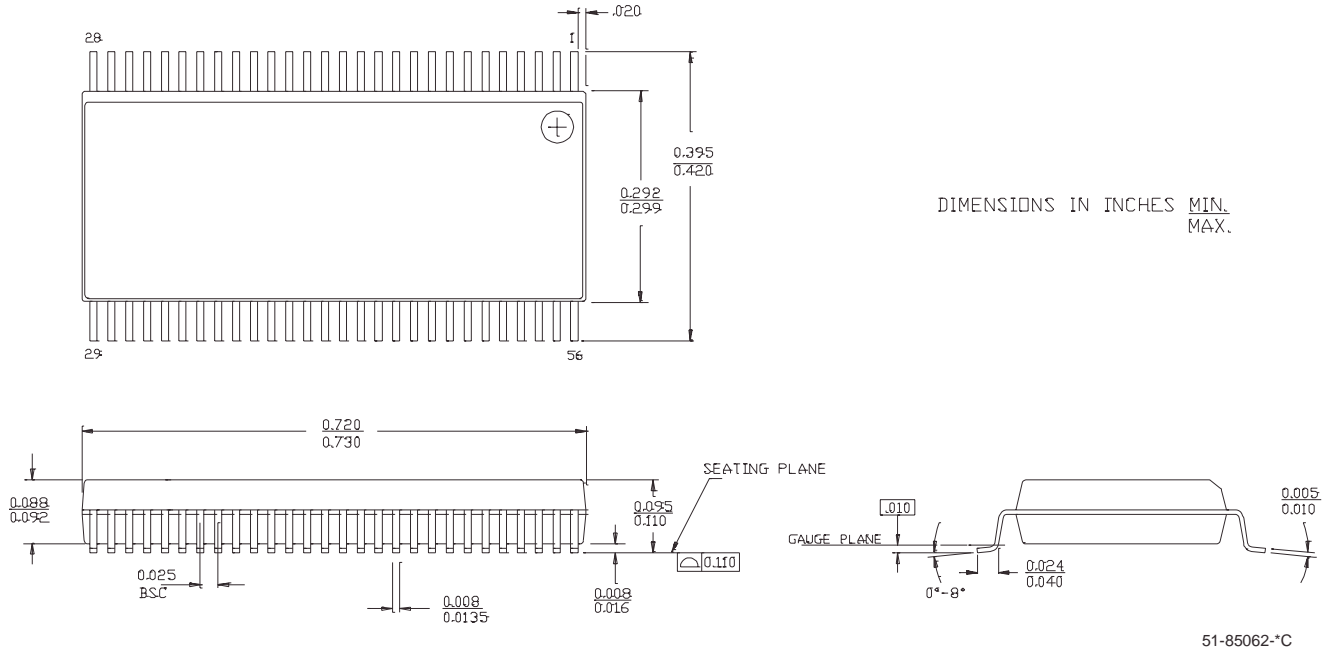
Ordering Code	Package Type	RAM Size	# Prog I/Os	8051 Address/Data Buses
CY7C68013-128AC	128 TQFP	8K	40	16/8 bit
CY7C68013-100AC	100 TQFP	8K	40	–
CY7C68013-56PVC	56 SSOP	8K	24	–
CY7C68013-56LFC	56 QFN	8K	24	–
CY7C68013-128AXC	128 TQFP Lead-Free Package	8K	40	16/8 bit
CY7C68013-100AXC	100 TQFP Lead-Free Package	8K	40	–
CY7C68013-56PVXC	56 SSOP Lead-Free Package	8K	24	–
CY7C68013-56LFXC	56 QFN Lead-Free Package	8K	24	–
CY3681	EZ-USB FX2 Xcelerator Development Kit			



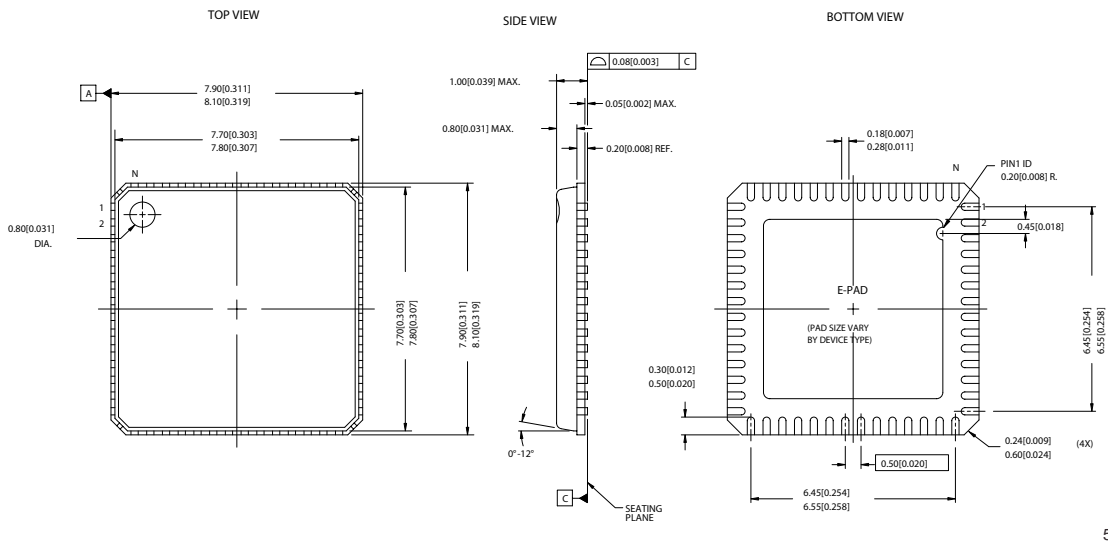
### 11.0 Package Diagrams

The FX2 is available in four packages:

- 56-pin SSOP
- 56-pin QFN
- 100-pin TQFP
- 128-pin TQFP.

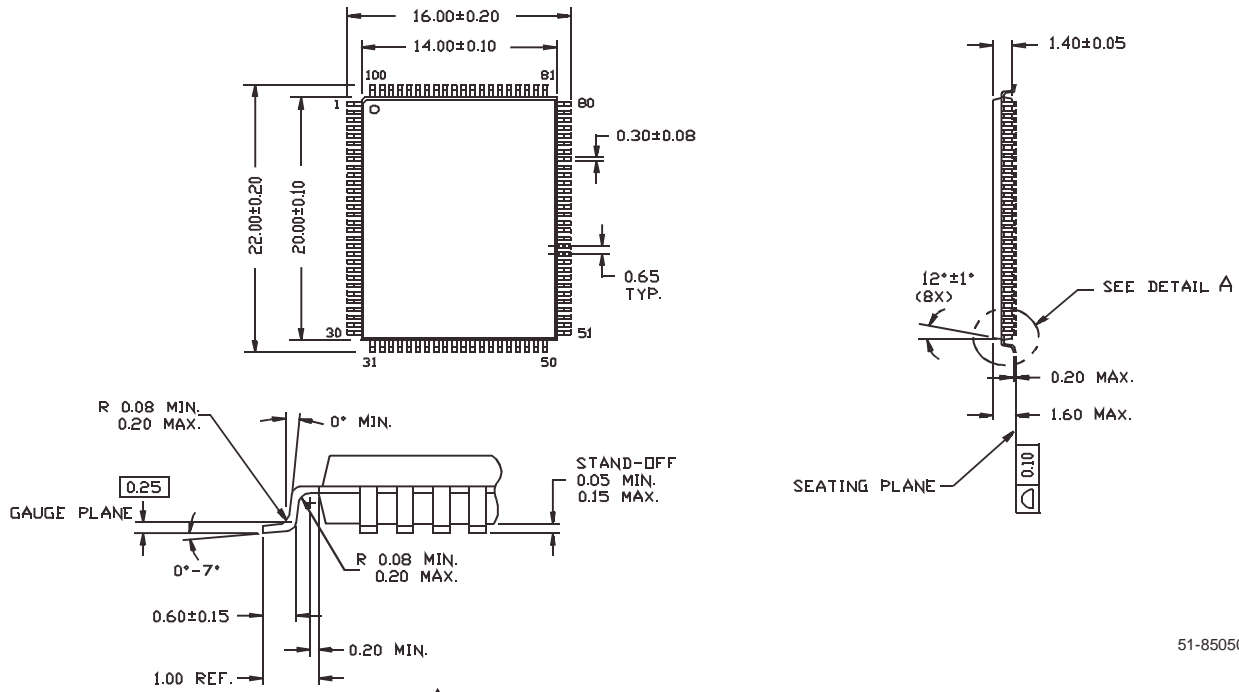


**Figure 11-1. 56-lead Shrunken Small Outline Package O56**



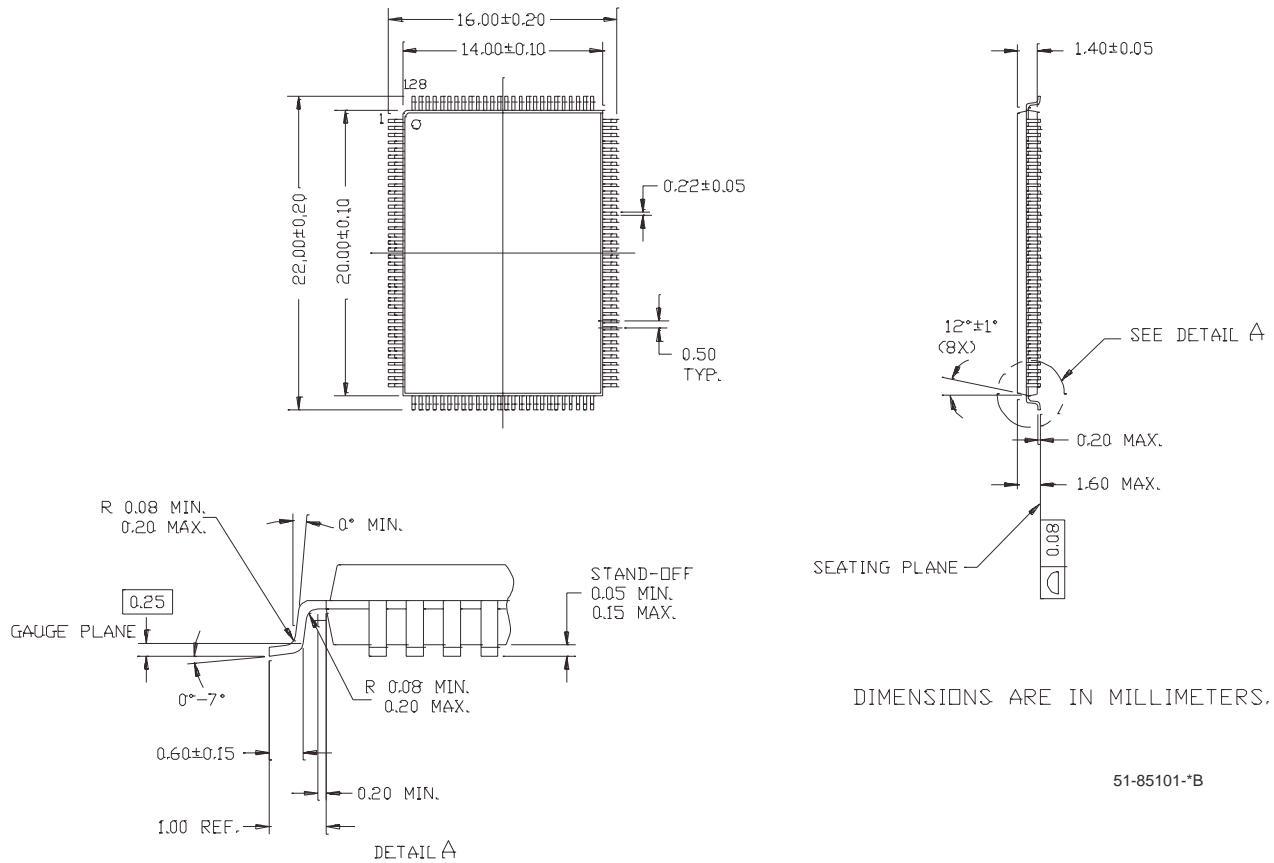
**Figure 11-2. 56-Lead QFN 8 x 8 MM LF56A**

DIMENSIONS ARE IN MILLIMETERS.



51-85050-A

Figure 11-3. 100-Pin Thin Plastic Quad Flatpack (14 x 20 x 1.4 mm) A101



DIMENSIONS ARE IN MILLIMETERS.

51-85101-B

Figure 11-4. 128-Lead Thin Plastic Quad Flatpack (14 x 20 x 1.4 mm) A128

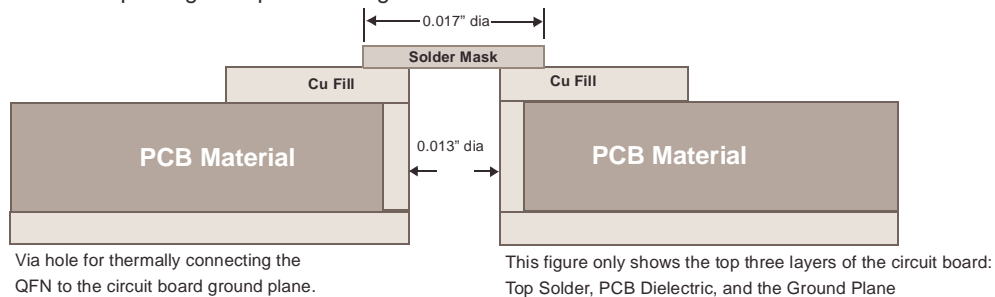
## 12.0 PCB Layout Recommendations<sup>[17]</sup>

The following recommendations should be followed to ensure reliable high-performance operation.

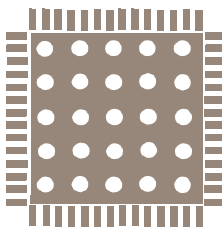
- At least a four-layer impedance controlled boards are required to maintain signal quality.
- Specify impedance targets (ask your board vendor what they can achieve).
- To control impedance, maintain trace widths and trace spacing.
- Minimize stubs to minimize reflected signals.
- Connections between the USB connector shell and signal ground must be done near the USB connector.
- Bypass/flyback caps on VBus, near connector, are recommended.
- DPLUS and DMINUS trace lengths should be kept to within two mm of each other in length, with preferred length of 20-30 mm.
- Maintain a solid ground plane under the DPLUS and DMINUS traces. Do not allow the plane to be split under these traces.
- It is preferred is to have no vias placed on the DPLUS or DMINUS trace routing.
- Isolate the DPLUS and DMINUS traces from all other signal traces by no less than 10 mm.

## 13.0 Quad Flat Package No Leads (QFN) Package Design Notes

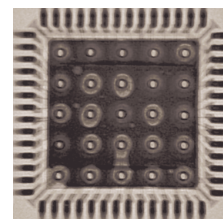
Electrical contact of the part to the Printed Circuit Board (PCB) is made by soldering the leads on the bottom surface of the package to the PCB. Hence, special attention is required to the heat transfer area below the package to provide a good



**Figure 13-1. Cross-section of the Area Underneath the QFN Package**



**Figure 13-2. Plot of the Solder Mask (White Area)**



**Figure 13-3. X-ray Image of the Assembly**

Note:

17. Source for recommendations: *EZ-USB FX2™ PCB Design Recommendations*, [http://www.cypress.com/cfuploads/support/app\\_notes/FX2\\_PCB.pdf](http://www.cypress.com/cfuploads/support/app_notes/FX2_PCB.pdf) and *High Speed USB Platform Design Guidelines*, [http://www.usb.org/developers/data/hs\\_usb\\_pdg\\_r1\\_0.pdf](http://www.usb.org/developers/data/hs_usb_pdg_r1_0.pdf).

Purchase of I<sup>2</sup>C components from Cypress, or one of its sublicensed Associated Companies, conveys a license under the Philips I<sup>2</sup>C Patent Rights to use these components in an I<sup>2</sup>C system, provided that the system conforms to the I<sup>2</sup>C Standard Specification as defined by Philips. EZ-USB FX2 and ReNumeration are trademarks, and EZ-USB is a registered trademark, of Cypress Semiconductor. All product and company names mentioned in this document are the trademarks of their respective holders.

thermal bond to the circuit board. A Copper (Cu) fill is to be designed into the PCB as a thermal pad under the package. Heat is transferred from the FX2 through the device's metal paddle on the bottom side of the package. Heat from here, is conducted to the PCB at the thermal pad. It is then conducted from the thermal pad to the PCB inner ground plane by a 5 x 5 array of via. A via is a plated through hole in the PCB with a finished diameter of 13 mil. The QFN's metal die paddle must be soldered to the PCB's thermal pad. Solder mask is placed on the board top side over each via to resist solder flow into the via. The mask on the top side also minimizes outgassing during the solder reflow process.

For further information on this package design please refer to the application note "Surface Mount Assembly of AMKOR's MicroLeadFrame (MLF) Technology." This application note can be downloaded from AMKOR's website from the following URL:

"[www.amkor.com/products/notes\\_papers/MLF\\_AppNote\\_0902.pdf](http://www.amkor.com/products/notes_papers/MLF_AppNote_0902.pdf)". The application note provides detailed information on board mounting guidelines, soldering flow, rework process, etc.

Figure 13-1 below display a cross-sectional area underneath the package. The cross section is of only one via. The solder paste template needs to be designed to allow at least 50% solder coverage. The thickness of the solder paste template should be 5 mil. It is recommended that "No Clean", type 3 solder paste is used for mounting the part. Nitrogen purge is recommended during reflow.

Figure 13-2 is a plot of the solder mask pattern and Figure 13-3 displays an X-Ray image of the assembly (darker areas indicate solder.).

**Document History Page**

Document Title: CY7C68013 EZ-USB FX2™ USB Microcontroller High-speed USB Peripheral Controller				
Document Number: 38-08012				
REV.	ECN NO.	Issue Date	Orig. of Change	Description of Change
**	111753	11/15/01	DSG	Changed from Spec number: 38-00929 to 38-08012
*A	111802	02/20/02	KKU	Updated functional changes between revision D part and revision E part Changed timing data from simulation data to revision E characterization data
*B	115480	06/26/02	KKU	Added new 56-pin Quad Flatpack No Lead package and pinout Revised pin description table to reflect new package Corrected <i>Figure 9-8</i> by moving tsfd parameter location Corrected labels on Dplus and Dminus in <i>Table 4-1</i> Removed Preliminary from spec title
*C	120776	01/06/03	KKU	Added bus powered references and PCB layout recommendations and QFN package design notes Updated QFN package drawing 51-85144 to current revision
*D	288810	See ECN	MON	Added lead-free packages Added timing sequence diagrams for slave FIFO read and write Changed PKTEND to FLAGS output propagation delay (asynchronous interface) in <i>Table 9-13</i> from a max value of 70 ns to 115 ns Changed FIFOADR[2:0] Hold Time ( $t_{FAH}$ ) for Asynchronous FIFO Interface as follows: SLRD/PKTEND to FIFOADR[2:0] Hold Time: 20 ns SLWR to FIFOADR[2:0] Hold Time: 70 ns
*E	317674	See ECN	MON	Provided additional timing restrictions and requirement regarding the use of PKTEND pin to commit a short one byte/word packet subsequent to committing a packet automatically (when in auto mode).
*F	352234	See ECN	MON	Added information on the AUTOPTR1/AUTOPT2 address timing with regards to data memory read/write timing diagram. Added information "This part is not recommended for new designs. Use EZ-USB FX2LP instead of EZ-USB FX2 for new designs"