



3 V SILICON RFIC FREQUENCY UPCONVERTER

UPC8106TB

FEATURES

- **RECOMMENDED OPERATING FREQUENCY:**
 $f_{RFout} = 0.4 \text{ GHz to } 2.0 \text{ GHz}$
 $f_{IFin} = 100 \text{ MHz to } 400 \text{ MHz}$
- **SUPPLY VOLTAGE:**
 $V_{CC} = 2.7 \text{ to } 5.5 \text{ V}$
- **HIGH DENSITY SURFACE MOUNTING:**
 6 pin super mini mold package
- **LOW CARRIER LEAKAGE:**
 Due to double balanced mixer
- **BUILT-IN POWER SAVE FUNCTION**

DESCRIPTION

NEC's UPC8106TB is a silicon RFIC designed as a frequency upconverter for cellular/cordless telephone transmitter stages and features improved intermodulation. This device is housed in a 6 pin super mini mold or SOT-363 package making it ideal for reducing system size. The UPC8106TB is manufactured using NEC's 20 GHz ft NESAT™III silicon bipolar process.

NEC's stringent quality assurance and test procedures ensure the highest reliability and performance.

INTERNAL BLOCK DIAGRAM

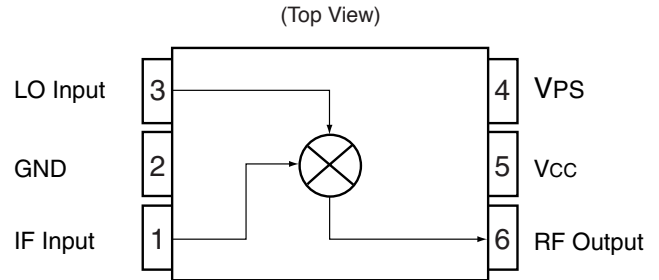

APPLICATION

- **CELLULAR/CORDLESS TELEPHONE**

ELECTRICAL CHARACTERISTICS

($T_A = 25^\circ\text{C}$, $V_{CC} = V_{RFout} = 3 \text{ V}$, $f_{IFin} = 240 \text{ MHz}$, $P_{LOin} = -5 \text{ dBm}$, $V_{PS} \geq 2.7 \text{ V}$ unless otherwise specified)

PART NUMBER PACKAGE OUTLINE			UPC8106TB S06		
SYMBOLS	PARAMETERS AND CONDITIONS	UNITS	MIN	TYP	MAX
I_{CC}	Circuit Current at $V_{PS} \geq 2.7 \text{ V}$ $V_{PS} = 0 \text{ V}$	mA μA	4.5	9	13.5 10
CG	Conversion Gain at $f_{RFout} = 0.9 \text{ GHz}$, $P_{IFin} = -30 \text{ dBm}$ $f_{RFout} = 1.9 \text{ GHz}$, $P_{IFin} = -30 \text{ dBm}$	dB dB	6 4	9 7	12 10
P_{SAT}	Saturated Output Power at $f_{RFout} = 0.9 \text{ GHz}$, $P_{IFin} = 0 \text{ dBm}$ $f_{RFout} = 1.9 \text{ GHz}$, $P_{IFin} = 0 \text{ dBm}$	dBm dBm	-4 -6.5	-2 -4	
OIP_3	Output Third-Order Intercept Point at $f_{IFin1} = 240.0 \text{ MHz}$ $f_{IFin2} = 240.4 \text{ MHz}$ $f_{RFout} = 0.9 \text{ GHz}$ $P_{IFin} = -20 \text{ dBm}$ $f_{RFout} = 1.9 \text{ GHz}$	dBm dBm		+5.5 +2.0	
IM_3	Third-Order Intermodulation Level at $f_{IFin1} = 240 \text{ MHz}$ $f_{IFin2} = 240.4 \text{ MHz}$ $f_{RFout} = 0.9 \text{ GHz}$ $P_{IFin} = -20 \text{ dBm}$ $f_{RFout} = 1.9 \text{ GHz}$	dBc dBc		-31 -30	
NF	SSB Noise Figure, $f_{RFout} = 0.9 \text{ GHz}$	dB		8.5	
$TPS(RISE)$	Power Save Rise Time at $V_{PS}: \text{GND} \rightarrow V_{CC}$	μS		2.0	
$TPS(FALL)$	Power Save Fall Time at $V_{PS}: V_{CC} \rightarrow \text{GND}$	μS		2.0	

ABSOLUTE MAXIMUM RATINGS¹ (T_A = 25°C)

SYMBOLS	PARAMETERS	UNITS	RATINGS
V _{CC}	Supply Voltage Pins 5 & 6	V	6.0
V _{PS}	Power Save Voltage	V	6.0
P _T	Total Power Dissipation ²	mW	200
T _{OP}	Operating Temperature	°C	-40 to +85
T _{STG}	Storage Temperature	°C	-55 to +150
P _{IN}	Input Power	dBm	+10

Notes:

1. Operation in excess of any one of these parameters may result in permanent damage.
2. Mounted on a 50 x 50 x 1.6 mm epoxy glass PWB (T_A = +85°C).

RECOMMENDED OPERATING CONDITIONS

SYMBOLS	PARAMETERS	UNITS	MIN	TYP	MAX
V _{CC}	Supply Voltage ¹	V	2.7	3.0	5.5
T _{OP}	Operating Temperature	°C	-40	+25	+85
P _{LO}	LO Input Level ²	dBm	-10	-5	0
f _{RFout}	RF Output Frequency ³	GHz	0.4		2.5
f _{IFin}	IF Input Frequency	MHz	100		400

Notes:

1. The same voltage should be supplied to pin 5 and 6.
2. Z_S = 50 Ω (without matching).
3. With external matching circuit.

TYPICAL PERFORMANCE CURVES (T_A = +25°C, V_{CC} = V_{RFout})

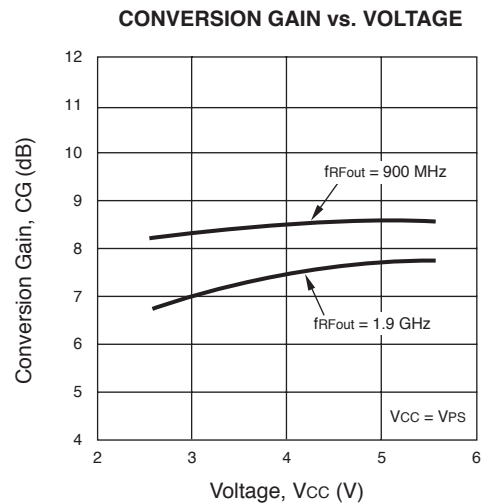
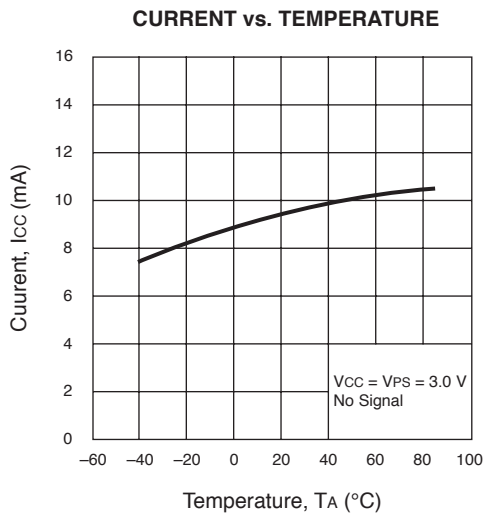
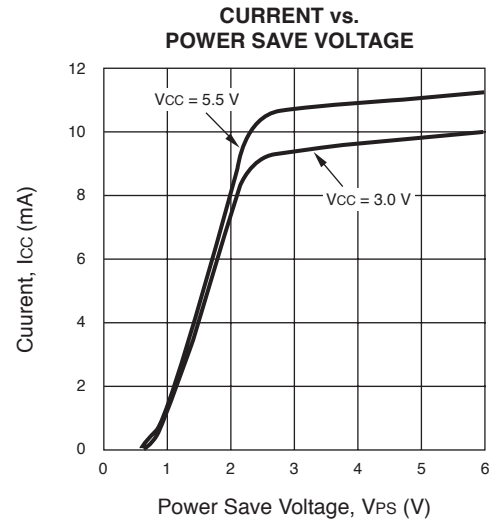
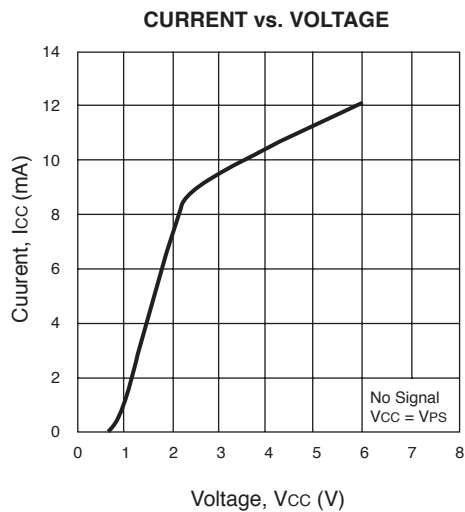

TYPICAL PERFORMANCE CURVES ($T_A = +25^\circ\text{C}$, $V_{CC} = V_{RFout}$)

CONVERSION GAIN vs. LOCAL INPUT LEVEL

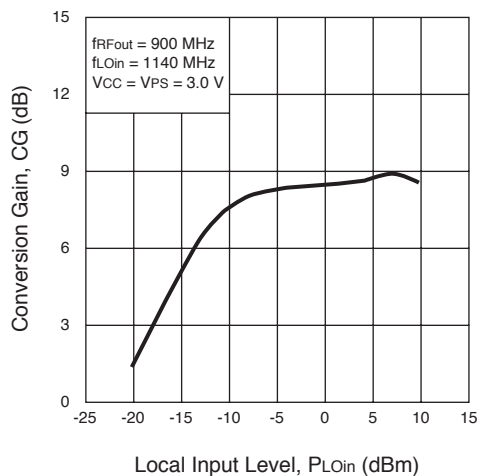

CONVERSION GAIN vs. LOCAL INPUT LEVEL

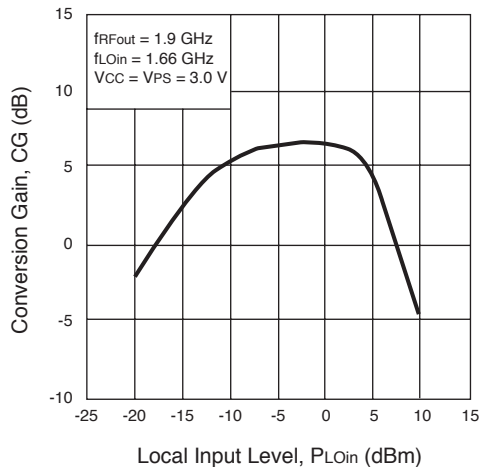

RF OUTPUT LEVEL AND IM3 vs. IF INPUT LEVEL

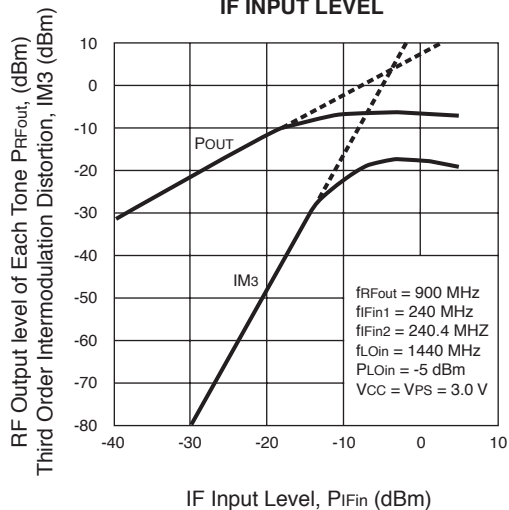

RF OUTPUT LEVEL AND IM3 vs. IF INPUT LEVEL

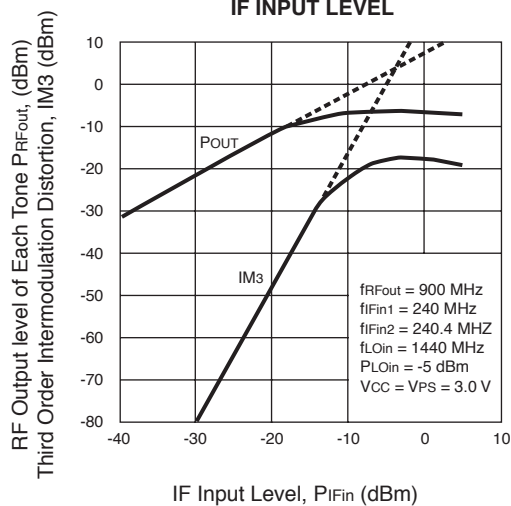

LOCAL LEAKAGE AT IF PIN vs. LOCAL INPUT FREQUENCY

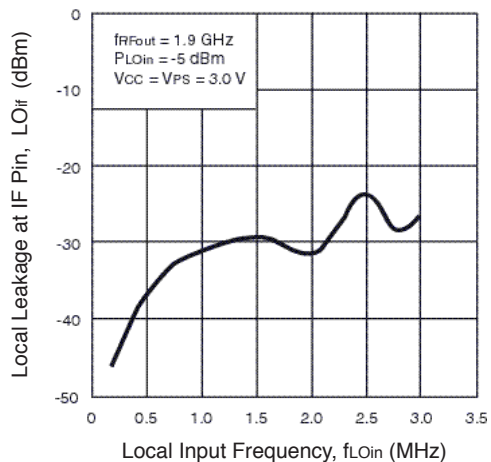

LOCAL LEAKAGE AT RF PIN vs. LOCAL INPUT FREQUENCY

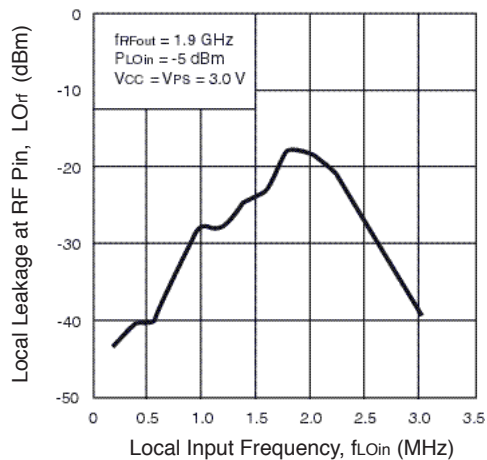

TYPICAL PERFORMANCE CURVES ($T_A = +25^\circ\text{C}$, $V_{CC} = V_{RFout}$)

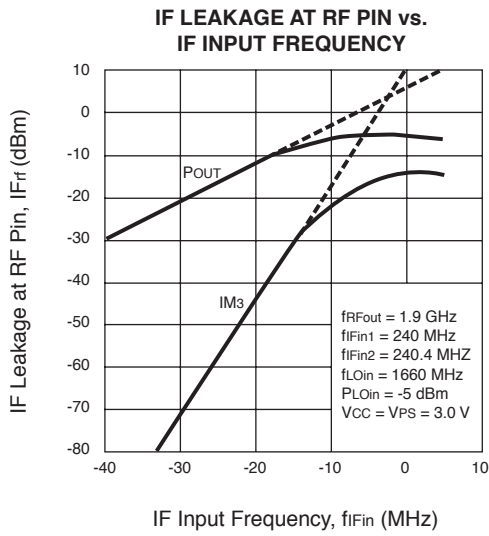

S-PARAMETERS FOR EACH PORT ($V_{CC} = V_{PS} = V_{RFout} = 3.0 \text{ V}$)

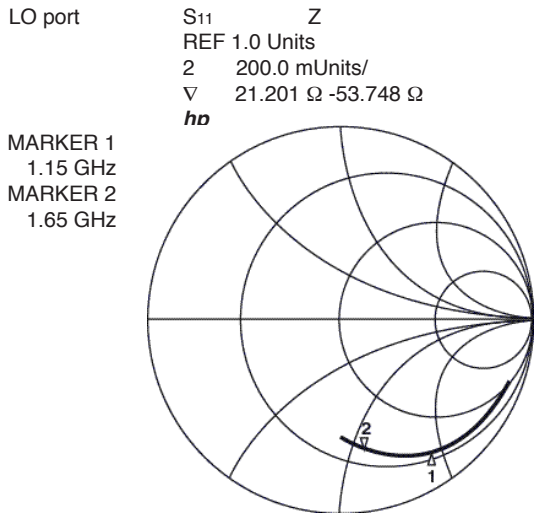

START 0.4 GHz

STOP 1.9 GHz

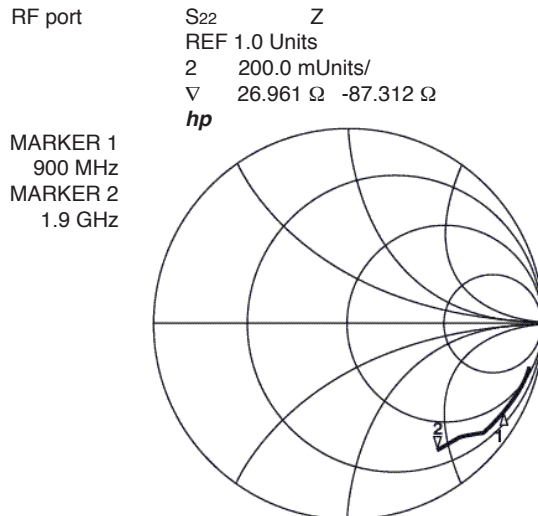

START 0.4 GHz

STOP 1.9 GHz

S-PARAMETERS FOR EACH PORT ($V_{CC} = V_{PS} = V_{RFout} = 3.0\text{ V}$)

IF port

S11 Z
 REF 1.0 Units
 1 200.0 mUnits/
 ∇ 194.16 Ω -579.53 Ω
hp

MARKER 1
 240 MHz

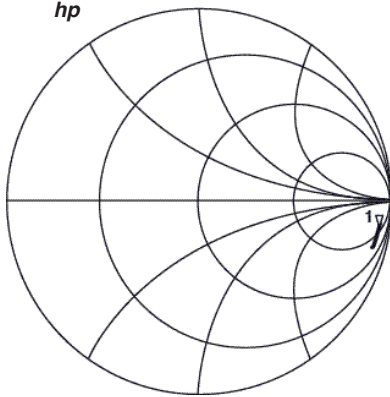

START 0.1 GHz STOP 0.4 GHz

S-PARAMETERS FOR MATCHED RF OUTPUT

($V_{CC} = V_{PS} = V_{RFout} = 3.0\text{ V}$) - with TEST CIRCUITS 1 and 2 - (S_{22} data is monitored at RF connector on board.)

900 MHz (LC-matched) in test circuit

S11 log MAG
 REF 0.0 dB
 1 10.0 dB/
 ∇ -19.567 dB
hp

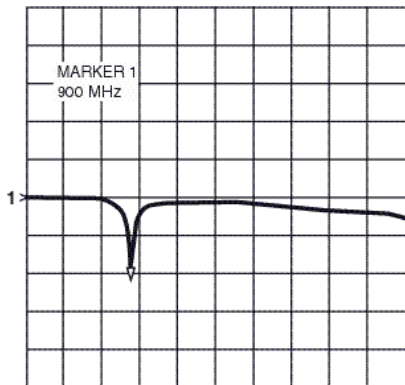

START 100 MHz STOP 3000 MHz

1.9 GHz (LC-matched) in test circuit

S22 log MAG
 REF 0.0 dB
 1 10.0 dB/
 ∇ -15.213 dB
hp

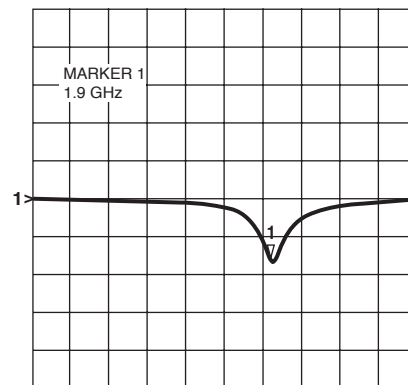

START 100 MHz STOP 3000 MHz

S22

REF 1.0 Units
 1 200.0 mUnits/
 ∇ 36.59 Ω 2.9355 Ω
hp

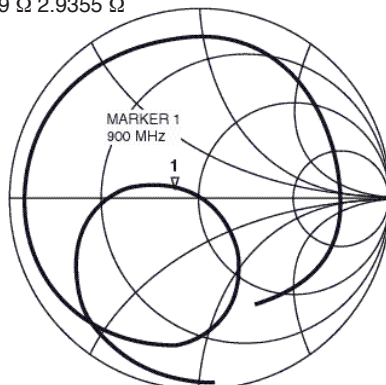

START 100 MHz STOP 3000 MHz

S22

REF 1.0 Units
 1 200.0 mUnits/
 ∇ 58.191 Ω -4.1191 Ω
hp

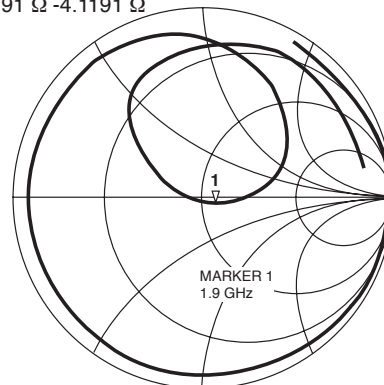

START 100 MHz STOP 3000 MHz

PIN FUNCTIONS

Pin No.	Symbol	Supply Voltage (V)	Pin ¹ Voltage (V)	Description	Equivalent Circuit						
1	IF Input	–	1.3	This pin is the IF input to the double balanced mixer. The input is a high impedance.							
2	GND	0	–	GND pin. Ground pattern on the board should be as wide as possible. Trace length should be kept as short as possible to minimize ground impedance.							
3	LOIN	–	2.4	LO input pin. Recommended input level is -10 to 0 dBm.							
5	Vcc	2.7 to 5.5	–	Supply voltage pin.							
6	RF Output	2.7 to 3.6	–	This pin is the RF output. This pin is designed as an open collector. Due to the high impedance output, this pin requires an external LC matching circuit.							
4	Vps	Vcc/GND	–	Power save control pin. Bias controls operation as follows: <table border="1" style="margin: 10px auto;"> <thead> <tr> <th>Pin Bias</th> <th>Control</th> </tr> </thead> <tbody> <tr> <td>Vcc</td> <td>ON</td> </tr> <tr> <td>GND</td> <td>Power Save</td> </tr> </tbody> </table>	Pin Bias	Control	Vcc	ON	GND	Power Save	
Pin Bias	Control										
Vcc	ON										
GND	Power Save										

Note:

1. Each pin voltage is measured with Vcc = Vps = VRFout = 3.0 V

SYSTEM APPLICATION EXAMPLE

EXAMPLE OF DECT 900 MHz Cordless Phone

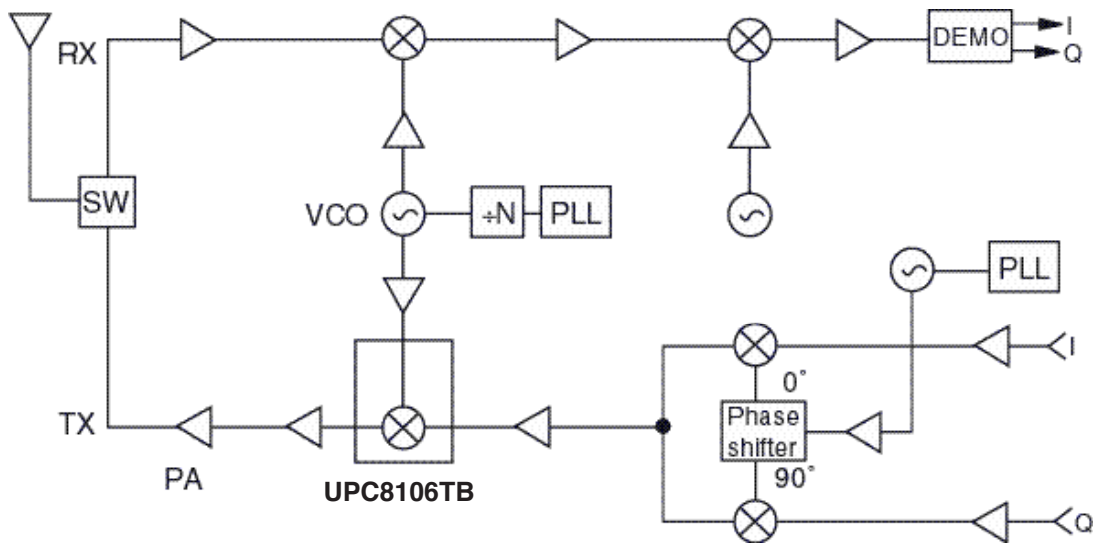

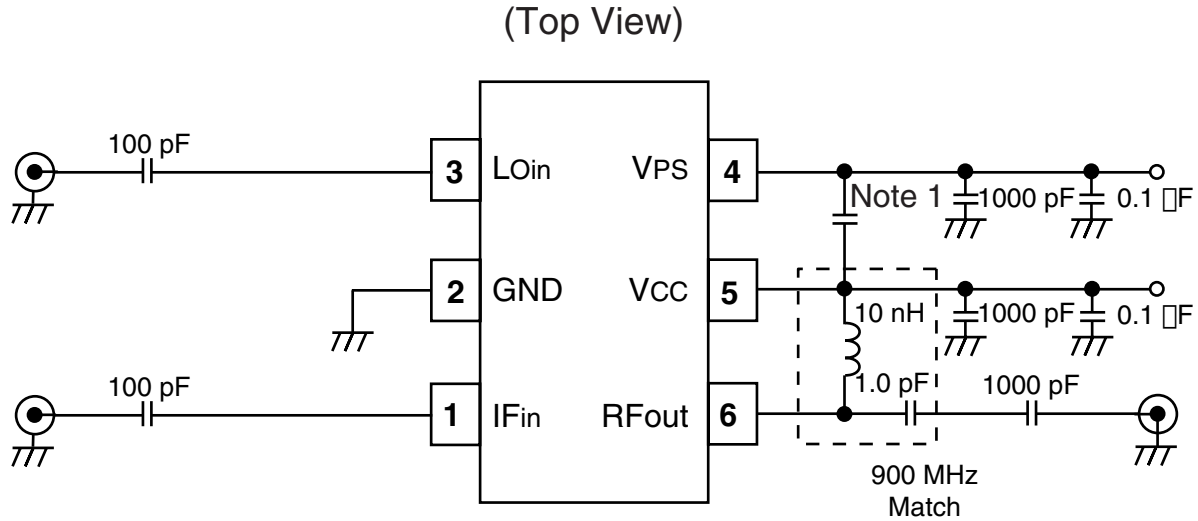
TEST CIRCUIT 1 ($R_{FOUT} = 900 \text{ MHz}$)

Note:

1. In case of unstable operation, connect 100 pF capacitor between pins 4 and 5.

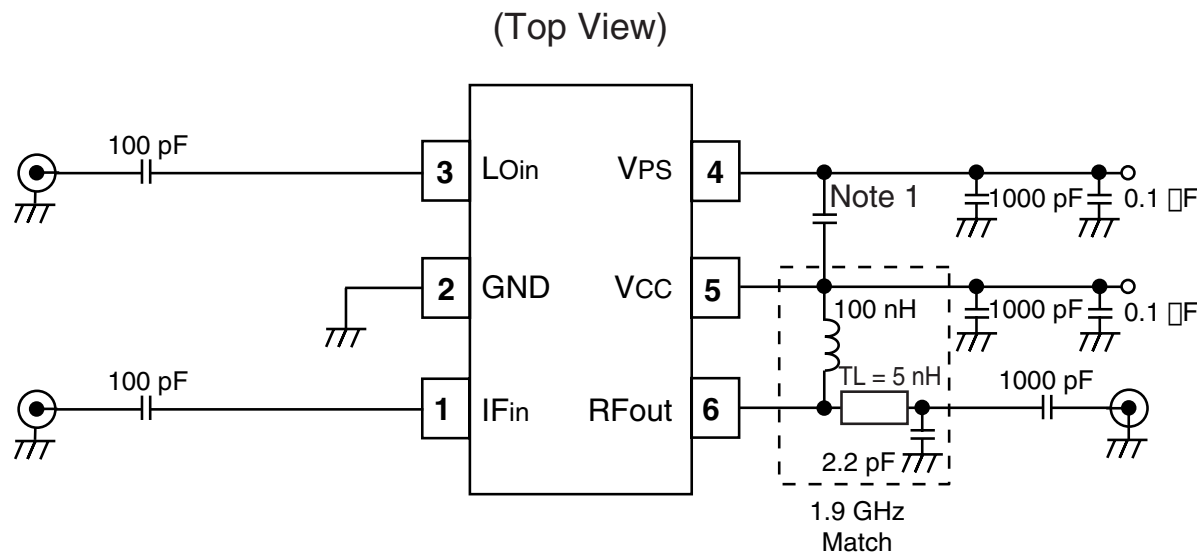
TEST CIRCUIT 2 ($R_{FOUT} = 1.9 \text{ GHz}$)

Note:

1. In case of unstable operation, connect 100 pF capacitor between pins 4 and 5.

OUTLINE DIMENSIONS (Units in mm)

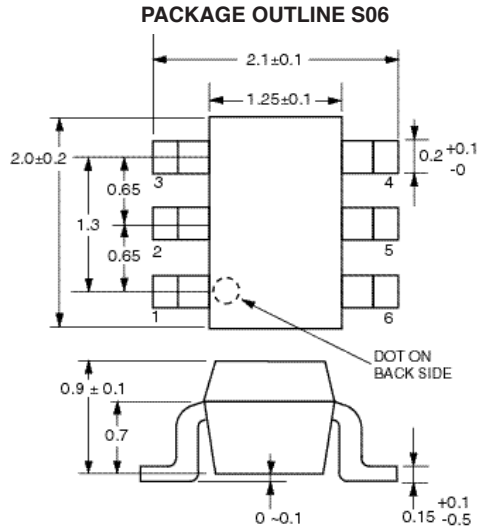

Note:
All dimensions are typical unless otherwise specified.

LEAD CONNECTIONS

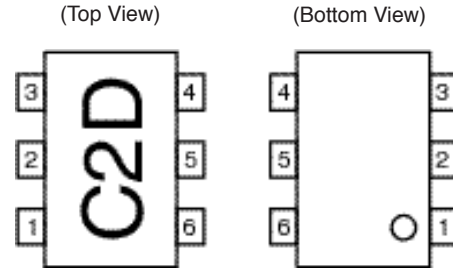

- 1. IF INPUT
- 2. GND
- 3. LO INPUT
- 4. POWER SAVE
- 5. V_{CC}
- 6. RF OUTPUT

ORDERING INFORMATION

PART NUMBER	QTY
UPC8106TB-E3-A	3K/Reel

Note:
Embossed Tape, 8 mm wide,
Pins 1, 2, and 3 face tape perforation side.

Life Support Applications

These NEC products are not intended for use in life support devices, appliances, or systems where the malfunction of these products can reasonably be expected to result in personal injury. The customers of CEL using or selling these products for use in such applications do so at their own risk and agree to fully indemnify CEL for all damages resulting from such improper use or sale.

CEL California Eastern Laboratories, Your source for NEC RF, Microwave, Optoelectronic, and Fiber Optic Semiconductor Devices.

4590 Patrick Henry Drive • Santa Clara, CA 95054-1817 • (408) 988-3500 • FAX (408) 988-0279 • www.cel.com

DATA SUBJECT TO CHANGE WITHOUT NOTICE

03/31/2008

NEC
A Business Partner of NEC Compound Semiconductor Devices, Ltd.

Subject: Compliance with EU Directives

CEL certifies, to its knowledge, that semiconductor and laser products detailed below are compliant with the requirements of European Union (EU) Directive 2002/95/EC Restriction on Use of Hazardous Substances in electrical and electronic equipment (RoHS) and the requirements of EU Directive 2003/11/EC Restriction on Penta and Octa BDE.

CEL Pb-free products have the same base part number with a suffix added. The suffix –A indicates that the device is Pb-free. The –AZ suffix is used to designate devices containing Pb which are exempted from the requirement of RoHS directive (*). In all cases the devices have Pb-free terminals. All devices with these suffixes meet the requirements of the RoHS directive.

This status is based on CEL’s understanding of the EU Directives and knowledge of the materials that go into its products as of the date of disclosure of this information.

Restricted Substance per RoHS	Concentration Limit per RoHS (values are not yet fixed)	Concentration contained in CEL devices	
		-A	-AZ
Lead (Pb)	< 1000 PPM	Not Detected	(*)
Mercury	< 1000 PPM	Not Detected	
Cadmium	< 100 PPM	Not Detected	
Hexavalent Chromium	< 1000 PPM	Not Detected	
PBB	< 1000 PPM	Not Detected	
PBDE	< 1000 PPM	Not Detected	

If you should have any additional questions regarding our devices and compliance to environmental standards, please do not hesitate to contact your local representative.

Important Information and Disclaimer: Information provided by CEL on its website or in other communications concerning the substance content of its products represents knowledge and belief as of the date that it is provided. CEL bases its knowledge and belief on information provided by third parties and makes no representation or warranty as to the accuracy of such information. Efforts are underway to better integrate information from third parties. CEL has taken and continues to take reasonable steps to provide representative and accurate information but may not have conducted destructive testing or chemical analysis on incoming materials and chemicals. CEL and CEL suppliers consider certain information to be proprietary, and thus CAS numbers and other limited information may not be available for release.

In no event shall CEL’s liability arising out of such information exceed the total purchase price of the CEL part(s) at issue sold by CEL to customer on an annual basis.

See CEL Terms and Conditions for additional clarification of warranties and liability.