

Features

- Low Insertion Loss: 0.8 dB at 5.2 GHz
- Ideal for WLAN IEEE 802.11a
- 0.5 micron GaAs PHEMT Process
- Integrated DC Blocking Capacitors
- Lead-Free 3 mm 12-Lead PQFN Package
- 100% Matte Tin Plating over Copper
- Halogen-Free "Green" Mold Compound
- 260°C Reflow Compatible
- RoHS* Compliant Version of MASWSS0039

Description

The MASWSS0175 is a GaAs pHEMT MMIC DPDT diversity switch in a lead-free 3 mm 12-lead PQFN package. It is designed for low insertion loss and allows for independent control and selection of each switch path. It integrates blocking capacitors on all RF ports and thus eliminates the need for additional off-chip DC blocking capacitors.

The MASWSS0175 is ideally suited for applications where very small size and low cost are required. Typical applications are for WLAN IEEE 802.11a systems that employ two antennas for transmit and receive diversity. This part can be used in all systems operating between 4.5 GHz and 6.0 GHz requiring moderate power and diversity switching.

The MASWSS0175 is fabricated using a 0.5 micron gate length GaAs pHEMT process. The process features full passivation for performance and reliability.

Ordering Information ¹

Part Number	Package
MASWSS0175	Bulk Packaging
MASWSS0175TR-3000	3000 Piece Reel
MASWSS0175SMB	Sample Test Board

1. Reference Application Note M513 for reel size information.

Functional Schematic

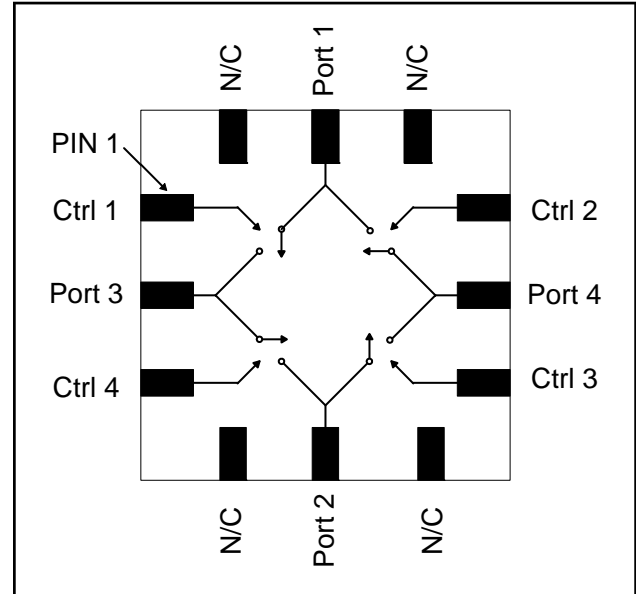

Pin Configuration ²

Pin No.	Pin Name	Description
1	Ctrl 1	Control 1
2	Port 3	RF Port 3
3	Ctrl 4	Control 4
4	N/C	No Connection
5	Port 2	RF Port 2
6	N/C	No Connection
7	Ctrl 3	Control 3
8	Port 4	RF Port 4
9	Ctrl 2	Control 2
10	N/C	No Connection
11	Port 1	RF Port 1
12	N/C	No Connection
13	Paddle ²	RF and DC Ground

2. The exposed pad centered on the package bottom must be connected to RF and DC ground.

* Restrictions on Hazardous Substances, European Directive 2002/95/EC.

1

ADVANCED: Data Sheets contain information regarding a product M/A-COM Technology Solutions is considering for development. Performance is based on target specifications, simulated results, and/or prototype measurements. Commitment to develop is not guaranteed.
PRELIMINARY: Data Sheets contain information regarding a product M/A-COM Technology Solutions has under development. Performance is based on engineering tests. Specifications are typical. Mechanical outline has been fixed. Engineering samples and/or test data may be available. Commitment to produce in volume is not guaranteed.

• **North America** Tel: 800.366.2266 • **Europe** Tel: +353.21.244.6400
 • **India** Tel: +91.80.43537383 • **China** Tel: +86.21.2407.1588
 Visit www.macomtech.com for additional data sheets and product information.

M/A-COM Technology Solutions Inc. and its affiliates reserve the right to make changes to the product(s) or information contained herein without notice.

Electrical Specifications: $T_A = 25^\circ\text{C}$, $Z_0 = 50 \Omega$, $V_C = 0 \text{ V} / 3 \text{ V}$

Parameter	Test Conditions	Units	Min.	Typ.	Max.
Insertion Loss	4.9 GHz	dB	—	0.9	1.3
	5.2 GHz		—	0.8	1.2
	5.8 GHz		—	0.8	1.2
Isolation	4.9 GHz	dB	15	20	—
	5.2 GHz		20	25	—
	5.8 GHz		20	29	—
Return Loss	4.5 - 6.0 GHz	dB	15	25	—
P1dB	5.2 GHz, $V_C = 2.7 \text{ V}$	dBm	—	31	—
	5.2 GHz, $V_C = 3.0 \text{ V}$		—	33	—
	5.2 GHz, $V_C = 5.0 \text{ V}$		—	39	—
IP2	Two Tone, +15 dBm / tone, 5 MHz Spacing 5.2 GHz	dBm	—	98	—
IP3	Two Tone, +15 dBm / tone, 5 MHz Spacing 5.2 GHz, $V_C = 3 \text{ V}$ 5.2 GHz, $V_C = 5 \text{ V}$	dBm	—	52	—
			—	55	—
2 nd Harmonic	5.2 GHz, $P_{IN} = 20 \text{ dBm}$	dBc	—	-85	—
3 rd Harmonic	5.2 GHz, $P_{IN} = 20 \text{ dBm}$	dBc	—	-83	—
Trise, Tfall	10% to 90% RF and 90% to 10% RF	ns	—	20	—
Ton, Toff	50% Control to 90% RF 50% Control to 10% RF	ns	—	35	—
			—	40	—
Control Current	$ V_C = 3 \text{ V}$	μA	—	5	25

Absolute Maximum Ratings ^{3,4}

Parameter	Absolute Maximum
Input Power @ 3 V Control	+32 dBm
Input Power @ 5 V Control	+36 dBm
Operating Voltage	+8.5 volts
Operating Temperature	-40°C to +85°C
Storage Temperature	-65°C to +150°C

- Exceeding any one or combination of these limits may cause permanent damage to this device.
- M/A-COM does not recommend sustained operation near these survivability limits.

Handling Procedures

Please observe the following precautions to avoid damage:

Static Sensitivity

Gallium Arsenide Integrated Circuits are sensitive to electrostatic discharge (ESD) and can be damaged by static electricity. Proper ESD control techniques should be used when handling these devices.

Typical Performance Curves

Insertion Loss

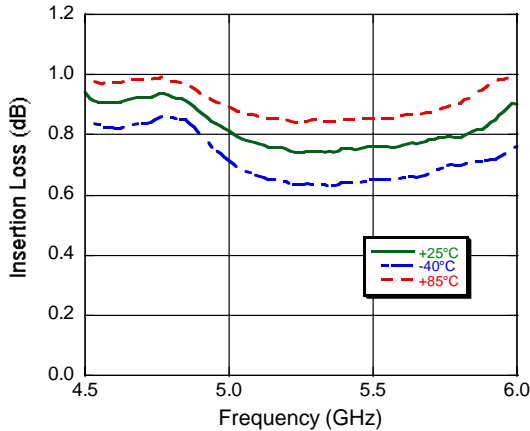

Isolation

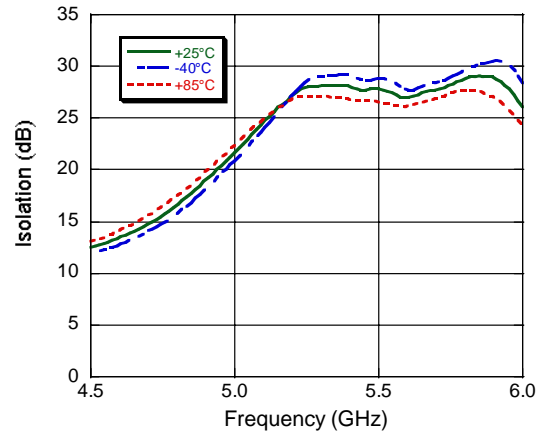

Return Loss

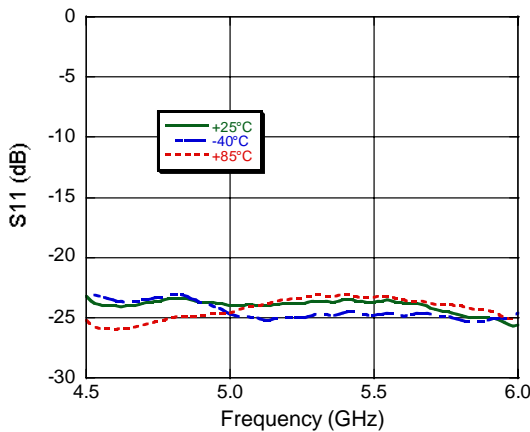

Circuit Block Diagram**

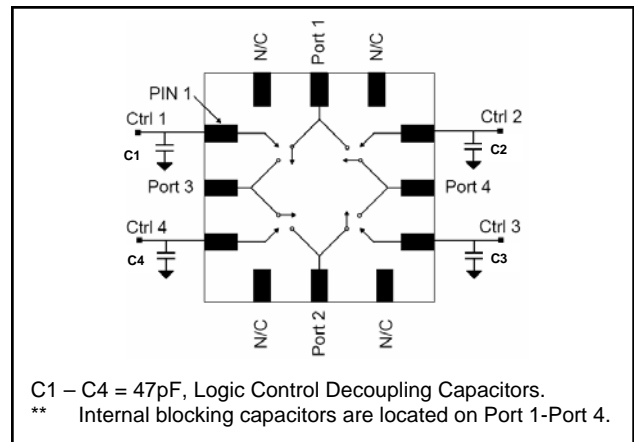

Truth Table 4,5

Control V1	Control V2	Control V3	Control V4	Port 1 - Port 3	Port 1 - Port 4	Port 2 - Port 4	Port 2 - Port 3
1	0	0	0	On	Off	Off	Off
0	1	0	0	Off	On	Off	Off
0	0	1	0	Off	Off	On	Off
0	0	0	1	Off	Off	Off	On
1	0	1	0	On	Off	On	Off
0	1	0	1	Off	On	Off	On

4. 1 = +2.5 V to +5 V, 0 = 0 V + 0.2 V.

5. Differential voltage, V (state 1) - V (state 0), must be 2.5 V minimum and must not exceed 8 V.

ADVANCED: Data Sheets contain information regarding a product M/A-COM Technology Solutions is considering for development. Performance is based on target specifications, simulated results, and/or prototype measurements. Commitment to develop is not guaranteed.
PRELIMINARY: Data Sheets contain information regarding a product M/A-COM Technology Solutions has under development. Performance is based on engineering tests. Specifications are typical. Mechanical outline has been fixed. Engineering samples and/or test data may be available. Commitment to produce in volume is not guaranteed.

• **North America** Tel: 800.366.2266 • **Europe** Tel: +353.21.244.6400
• **India** Tel: +91.80.43537383 • **China** Tel: +86.21.2407.1588
Visit www.macomtech.com for additional data sheets and product information.

M/A-COM Technology Solutions Inc. and its affiliates reserve the right to make changes to the product(s) or information contained herein without notice.

