



## NXP voice solutions BGB203/4 with integrated LifeVibes Voice software

# Bluetooth for headsets and carkits

These premium Bluetooth 1.2 voice solutions combine low power with high quality in a very small footprint. Optimized for use in headsets and carkits, they speed time-to-market for voice-enabled designs.

### Key features

- ▶ Optimized Bluetooth 1.2 solutions for headsets and carkits
- ▶ BGB203 and BGB204 Bluetooth 1.2 SiPs
  - Smallest complete solutions in cost-effective packages
  - Certified plug-and-play operation
  - Transmit power +5 dBm at antenna port
  - Sensitivity -88 dBm at antenna port
  - Embedded Flash (BGB203) or ROM (BGB204)
  - Footprint-compatible HVQFN packages (BGB203: 56 mm<sup>2</sup>, BGB204: 49 mm<sup>2</sup>)
- ▶ PCF87757 1.8-V voice codec
  - Low-power, low-noise support for microphones and headphones
  - Smallest available size (3x3 mm HVQFN)
  - Optimized for use with BGB203/4 Bluetooth SiPs
- ▶ LifeVibes Voice software enhancement algorithms
  - Noise Void: eliminates unwanted background noise
  - Voice Clarity: improves intelligibility of speech
  - Handsfree: cancels acoustic echo for clear, simultaneous conversations
- ▶ Talk time: up to 8 hours (with LifeVibes) or 10 hours (without LifeVibes) using 150-mAh battery
- ▶ Standby time: 20+ days with 150-mAh battery

The NXP BGB203/4 voice solutions with integrated LifeVibes Voice software algorithms provide patented technology that ensures clear, noise-free conversations in even the most adverse environments. Designed for use in headsets and carkits, these solutions include a BGB203 or a BGB204 Bluetooth 1.2 System-in-Package (SiP), a PCF87757 1.8V voice codec, and software enhancements that eliminate unwanted background noise, improve the intelligibility of speech, and cancel acoustic echo.

Trying to talk in a noisy place like an airport, a shopping center, or along a busy street can be difficult with a mobile phone, especially when using a headset or a carkit. People often have to speak loudly to be heard and have trouble understanding or being understood. BGB203/4 voice solutions with LifeVibes Voice address this problem by removing background noise and improving sound sources. People can speak normally and naturally, no matter where they are.



Offered by NXP Software, LifeVibes Voice software enhancement algorithms are the result of extensive research. By studying the abilities and limitations of human hearing, audio perception, acoustical environments in everyday life, and the emotional impact sounds has on us, NXP Software has made great progress in, for example, determining how we locate sound sources and how we distinguish between simultaneous sounds. This know-how is designed into the three LifeVibes Voice algorithms optimized for headsets and carkit applications: Noise Void, Voice Clarity, and Hands Free.

### Headset Applications

Noise Void solves the problem of not being understood by removing stationary background noise while maintaining the naturalness of human speech.

Voice echo, particularly in small headsets, can have a serious impact on the quality of communications. Acoustical coupling between the earpiece and the microphone can create considerable time echo and can affect the overall quality of a call. Noise Void includes full-duplex acoustic echo cancellation that dramatically reduces echo in even the smallest of headsets.

Voice Clarity measures the amount of background noise and automatically boosts the intelligibility of speech by making the incoming voice more understandable. Voice Clarity requires little processing power and low memory usage, so it has a negligible effect on battery life. Voice Clarity, which focuses on the earpiece and the speaker, complements Noise Void, which primarily impacts the microphone.

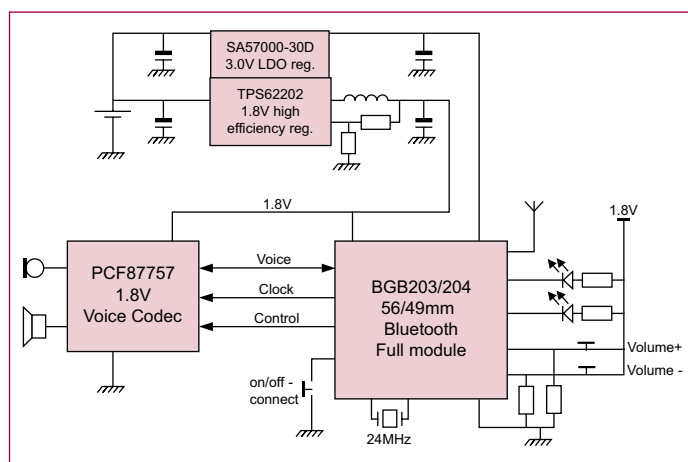

NXP voice solution for handsets and carkits BGB203/4

### Carkit Applications

In cars, sound is reproduced by the car's speakers or by the speakers of a carkit. Hands Free is optimized for use in carkits and cancels the acoustical echo in full-duplex calls, so people can have naturally flowing conversations without having to repeat themselves. Hands Free also removes stationary background noise, from the engine, for example, so the words come through loud and clear.

### Bluetooth 1.2 SiPs BGB203/4

The BGB203 and the BGB204 are complete, plug-and-play Bluetooth 1.2 SiPs that integrate a Bluetooth baseband, a full radio, and embedded memory. The BGB203 integrates embedded Flash, while the BGB204 integrates embedded ROM. The BGB203 and the BGB204 are complete, plug-and-play Bluetooth 1.2 SiPs that offer superior performance in a very small footprint.

The SiP approach increases integration while improving performance, because active and passive components are produced in the best technology for each subsystem. The BGB203 integrates a Bluetooth baseband, a full radio, and embedded Flash memory. The BGB204 is the same as the BGB203, but replaces the Flash memory with ROM. The two SiPs are footprint compatible.

Both SiPs deliver excellent RF performance, with a transmit power of +5 dBm and a sensitivity of -88 dBm at the antenna port. Using a 150-mAh battery, the BGB204 delivers up to 10 hours of talk time and up to 25 days of standby time. Only three external components are required for complete operation, and both SiPs are designed to co-exist with 802.11 Wireless LAN.

### 1.8-V voice codec PCF87757

The PCF87757, a voice codec that offers low-power, low-noise support for microphones and headphones, uses a 1.8-V supply to support low-cost headset applications. Available in a tiny HVQFN package that measures only 3x3 mm, it is one of the smallest 1.8-V voice codecs available on the market today. It is optimized for use with the BGB203 and BGB204.

[www.nxp.com](http://www.nxp.com)



© 2007 NXP B.V.

All rights reserved. Reproduction in whole or in part is prohibited without the prior written consent of the copyright owner. The information presented in this document does not form part of any quotation or contract, is believed to be accurate and reliable and may be changed without notice. No liability will be accepted by the publisher for any consequence of its use. Publication thereof does not convey nor imply any license under patent- or other industrial or intellectual property rights.

Date of release: July 2007

Document order number: 9397 750 16111

Printed in the Netherlands