

BlueMoon Single Cellular

PMB 8761

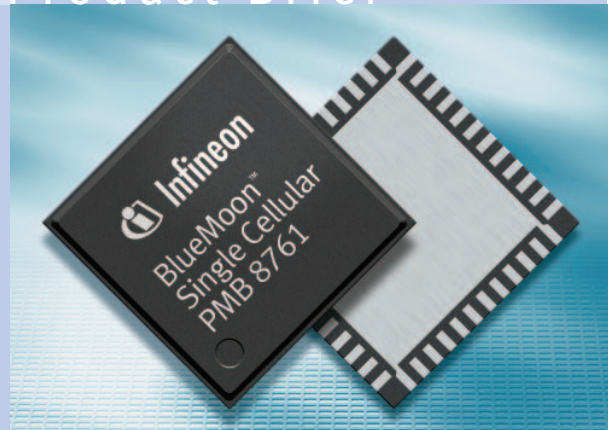

BlueMoon® Single Cellular is the optimized Bluetooth® wireless solution for cost-sensitive cellular phone applications. The advanced architecture out of the BlueMoon Single family combines minimal power consumption with excellent RF performance. The high integration level and a cost efficient VQFN package result in an extremely low board area of less than 80 mm² and industry leading cost of ownership.

Being compliant to Bluetooth Standard 1.2 BlueMoon Single Cellular is a reliable solution for the mobile future.

Applications

- Headset and Handsfree
- Dial-up networking
- Data transfer (e.g. object push)
- Synchronization
- Cordless telephony
- Advanced audio

Key Benefits

- True single chip
- Low power consumption
- Smallest size, highest integration, lowest BoM

Key Features

- Bluetooth 1.2 Support
 - Extended SCO
 - Adaptive frequency hopping
 - Fast connection setup
- Integrated ROM for lowest cost
- Programmable power-down mode
- Clock input for joint use with GSM/CDMA/3G clocks (11.5 to 46 MHz)
- Full automatic tuning and trimming (no manual or SW tuning)
- High RF sensitivity (-85 dBm @ 0.1% BER)
- On-chip 2.4 GHz RF driver amplifier with max. +7 dBm output power
- Automatic control of output power for reduced power consumption
- Compatible to available GSM/GPRS/CDMA base band solutions
- P-VQFN-48 package (lead-free/halogen-free)

Note: The Bluetooth word mark is owned by the Bluetooth SIG, Inc. and any use of this mark by Infineon Technologies AG is under license. The BlueMoon trade mark is owned by Infineon Technologies AG.

www.infineon.com/bluetooth

Wireless Communication



Never stop thinking.

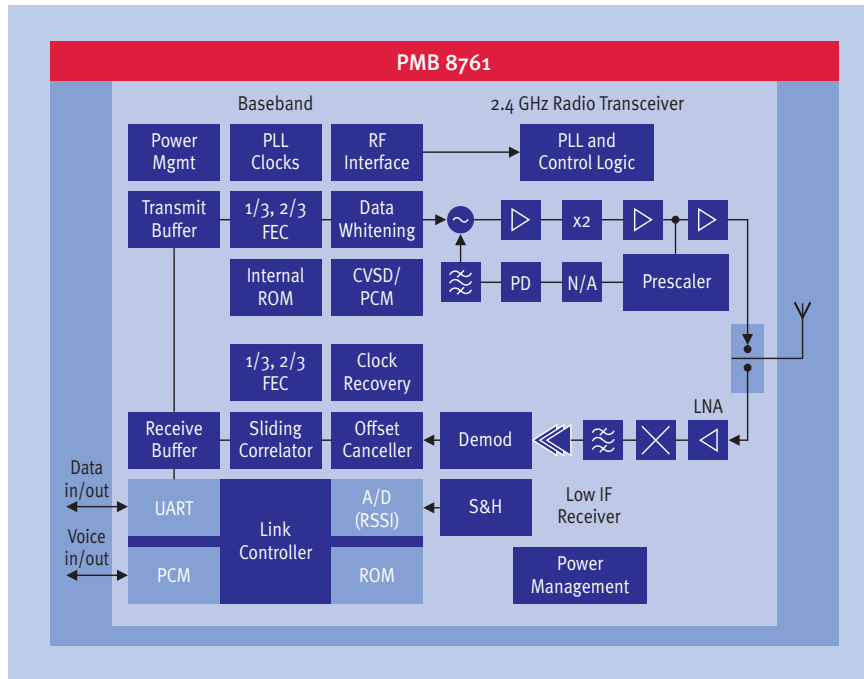

Block Diagram

- UART (2, 4 wired)
- PCM (A-law, μ -law)
- External oscillator
- Control lines for Class 1 PA
- Wake up line
- External 32 kHz low power oscillator
- Integrated RF switch

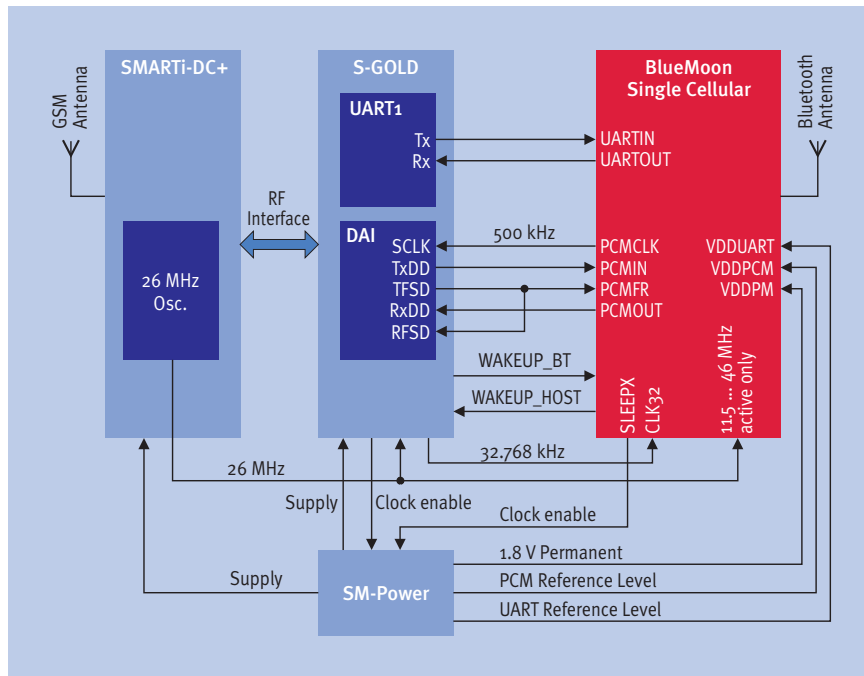

Application Example Mobile Phone with Bluetooth

Due to its small package size and because of few external components, BlueMoon Single Cellular is the perfect IC solution for Bluetooth enabled cell phones. In this example, the BlueMoon Single Cellular is built into a GSM mobile phone design based on Infineon's cellular ICs. This solution perfectly meets cost and size requirements of the final product.

How to reach us:
<http://www.infineon.com>

Published by
Infineon Technologies AG,
St.-Martin-Strasse 53,
D-81669 München

© Infineon Technologies AG 2004.
All Rights Reserved.

Template: pb_tmplt.fm/4/2004-01-01

Attention please!

The information herein is given to describe certain components and shall not be considered as a guarantee of characteristics. Terms of delivery and rights to technical change reserved.

We hereby disclaim any and all warranties, including but not limited to warranties of non-infringement, regarding circuits, descriptions and charts stated herein.

Information

For further information on technology, delivery terms and conditions and prices please contact your nearest Infineon Technologies Office.

Warnings

Due to technical requirements components may contain dangerous substances. For information on the types in question please contact your nearest Infineon Technologies Office.

Infineon Technologies Components may only be used in life-support devices or systems with the express written approval of Infineon Technologies, if a failure of such components can reasonably be expected to cause the failure of that life-support device or system, or to affect the safety or effectiveness of that device or system. Life support devices or systems are intended to be implanted in the human body, or to support and/or maintain and sustain and/or protect human life. If they fail, it is reasonable to assume that the health of the user or other persons may be endangered.