ST-NXP Wireless

IMPORTANT NOTICE

Dear customer,

As from August 2nd 2008, the wireless operations of STMicroelectronics have moved to a new company, ST-NXP Wireless.

As a result, the following changes are applicable to the attached document.

- **Company name** - **STMicroelectronics NV** is replaced with **ST-NXP Wireless**.
- **Copyright** - the copyright notice at the bottom of the last page "© STMicroelectronics 200x - All rights reserved", shall now read: "© ST-NXP Wireless 200x - All rights reserved".
- **Web site** - <http://www.st.com> is replaced with <http://www.stnwireless.com>
- **Contact information** - the list of sales offices is found at <http://www.stnwireless.com> under Contacts.

If you have any questions related to the document, please contact our nearest sales office. Thank you for your cooperation and understanding.

ST-NXP Wireless

ST-NXP Wireless

www.stnwireless.com

Bluetooth™ baseband with integrated flash

Not For New Design

Features

- Pin-to-pin compatible with the previous version STLC2415
- Ericsson Technology Licensing Baseband Core (EBC)
- Bluetooth™ specification compliance: V1.1 and V1.2
- SW compatible with STLC2411-M28R400CT combination
- 2 layer class 4 PCB compatible
- Point-to-point, point-to-multi-point (up to 7 slaves) and scatternet capability
- Asynchronous Connection Oriented (ACL) logical transport link
- Synchronous Connection Oriented (SCO) links: 2 simultaneous SCO channels
- Supports Pitch-period Error Concealment (PPEC)
 - Improves speech quality in the vicinity of interference
 - Improves coexistence with WLAN
 - Works at receiver, no Bluetooth implication
- Adaptive Frequency Hopping (AFH): hopping kernel, channel assessment as master and as slave
- Faster connection: interlaced scan for page and inquiry scan, first FHS without random backoff, RSSI used to limit range
- Extended SCO (eSCO) links
- Standard BlueRF bus interface
- QoS flush
- Clock support
- ARM7TDMI 32-bit CPU
- Memory organization
 - Integrated 4 Mbit flash
 - 64 KByte on-chip RAM
 - 4 KByte on-chip boot ROM

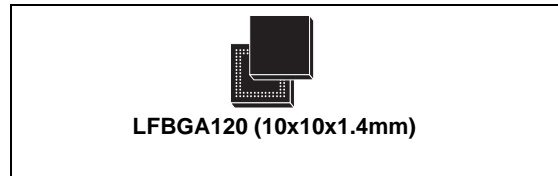

- Low power architecture with 2 different low power levels: sleep mode and deep sleep mode
- HW support for packet types
- Communication interfaces
 - Synchronous serial interface supporting up to 32 bit data and different industry standards
 - Two enhanced 16550 UARTs
 - 12 Mbps USB interface
 - Fast master I2C bus interface
 - Multi slot PCM interface
 - 16 programmable GPIOs
 - 2 external interrupts and various interrupt possibilities through other interfaces
- Efficient support for WLAN coexistence in collocated scenario
- Ciphering support for up to 128-bit key
- Receiver Signal Strength Indication (RSSI) support for power-controlled links
- Separate control for external power amplifier (PA) for class1 power support.
- Software support

Description

The E-STLC2416 from STMicroelectronics is a Bluetooth™ baseband controller with integrated 4 Mbit flash memory. Together with a Bluetooth™ Radio this product offers a compact and complete solution for short-range wireless connectivity. It incorporates all the lower layer functions of the Bluetooth™ protocol.

Contents

1	Overview	4
2	Quick reference data	6
2.1	Absolute maximum ratings	6
2.2	Operating ranges	6
2.3	I/O specifications	7
2.3.1	Specifications for 3.3V I/Os	7
2.3.2	Specifications for 1.8V I/Os	7
2.4	Current consumption	8
3	Block diagram and electrical schematics	9
4	Pinout	10
4.1	Pin description and assignment	10
5	Functional description	17
5.1	Baseband	17
5.1.1	Baseband 1.1 features	17
5.1.2	Baseband 1.2 features	17
5.2	Integrated Flash memory	18
5.2.1	Flash signal descriptions	18
6	General specification	20
6.1	System clock	20
6.1.1	Slow clock	20
6.2	Boot procedure	20
6.3	Clock detection	20
6.4	Master reset	21
6.5	Interrupts/wake-up	21
6.6	V1.2 detailed functionality - Extended SCO	21
6.7	V1.2 detailed functionality - Adaptive frequency hopping	21
6.8	V1.2 detailed functionality - Faster connection	22
6.9	V1.2 detailed functionality - Quality of service	22

6.10	Low power modes	23
6.10.1	Sniff or park	23
6.10.2	Inquiry/page scan	23
6.10.3	No connection	23
6.10.4	Active link	24
6.11	SW initiated low power mode	24
6.12	Bluetooth - WLAN coexistence in collocated scenario	24
6.12.1	Algorithm 1: PTA (Packet Traffic Arbitration)	24
6.12.2	Algorithm 2: WLAN master	25
6.12.3	Algorithm 3: Bluetooth master	25
6.12.4	Algorithm 4: two-wire mechanism	25
6.12.5	Algorithm 5: alternating wireless medium access (AWMA)	26
7	Interfaces	27
7.1	UART Interface	27
7.2	Synchronous serial interface	27
7.2.1	Feature description: Agilent mode	28
7.2.2	Feature description: 32-bit SPI	28
7.3	I2C interface	29
7.4	USB interface	29
7.5	JTAG Interface	29
7.6	RF Interface	30
7.7	PCM voice interface	30
8	HCI UART transport layer	32
8.1	UART settings	32
9	HCI USB transport layer	33
10	Class1 power support	34
11	Package mechanical data	35
12	Ordering information	36
13	Revision history	36

1 Overview

The E-STLC2416 from STMicroelectronics is a Bluetooth™ baseband controller with integrated 4 Mbit flash memory. Together with a Bluetooth™ Radio this product offers a compact and complete solution for short-range wireless connectivity. It incorporates all the lower layer functions of the Bluetooth™ protocol.

The microcontroller allows the support of all data packets of Bluetooth™ in addition to voice. The embedded controller can be used to run the Bluetooth™ protocol and application layers if required. The software is located in the integrated flash memory.

Detailed list of features

- Pin-to-pin compatible with the previous version STLC2415
- Ericsson Technology Licensing Baseband Core (EBC)
- Bluetooth™ specification compliance: V1.1 and V1.2
- SW compatible with STLC2411-M28R400CT combination
- 2 layer class 4 PCB compatible
- Point-to-point, point-to-multi-point (up to 7 slaves) and scatternet capability
- Asynchronous Connection Oriented (ACL) logical transport link
- Synchronous Connection Oriented (SCO) links: 2 simultaneous SCO channels
- Supports Pitch-period Error Concealment (PPEC)
 - Improves speech quality in the vicinity of interference
 - Improves coexistence with WLAN
 - Works at receiver, no Bluetooth implication
- Adaptive Frequency Hopping (AFH): hopping kernel, channel assessment as master and as slave
- Faster connection: interlaced scan for page and inquiry scan, first FHS without random backoff, RSSI used to limit range
- Extended SCO (eSCO) links

- Standard BlueRF bus interface
- QoS flush
- Clock support
 - System clock input at 13 and 26 MHz
 - LPO clock input at 3.2 and 32 kHz
- ARM7TDMI 32-bit CPU
- Memory organization
 - Integrated 4 Mbit flash
 - 64KByte on-chip RAM
 - 4KByte on-chip boot ROM
- Low power architecture with 2 different low power levels: sleep mode and deep sleep mode
- HW support for packet types
 - ACL: DM1, 3, 5 and DH1, 3, 5
 - SCO: HV1, 3 and DV
 - eSCO: EV3, 5
- Communication interfaces
 - Synchronous serial interface, supporting up to 32 bit data and different industry standards
 - Two enhanced 16550 UARTs with 128 byte FIFO depth
 - 12 Mbps USB interface
 - Fast master I2C bus interface
 - Multi slot PCM interface
 - 16 programmable GPIOs
 - 2 external interrupts and various interrupt possibilities through other interfaces
- Efficient support for WLAN coexistence in collocated scenario
- Ciphering support for up to 128-bit key
- Receiver Signal Strength Indication (RSSI) support for power-controlled links
- Separate control for external power amplifier (PA) for class1 power support.
- Software support
 - Low level (up to HCI) stack or embedded stack with profiles
 - Support of UART and USB HCI transport layers.

Typical applications

- Cable replacement
- Portable computers
- PDA, modems
- Handheld data transfer devices
- Cameras, computer peripherals
- Other type of devices that require the wireless communication provided by Bluetooth™

2 Quick reference data

2.1 Absolute maximum ratings

Operation of the device beyond these conditions is not guaranteed.
Sustained exposure to these limits will adversely affect device reliability.

Table 1. Absolute maximum ratings

Symbol	Conditions	Min	Max	Unit
V_{DD}	Supply voltage baseband core	$V_{SS} - 0.5$	2.5	V
V_{DDF}	Supply voltage flash	$V_{SS} - 0.5$	2.5	V
V_{PP}	Fast Program Voltage	$V_{SS} - 0.5$	13	V
V_{DDIO}	Supply voltage baseband I/O		4	V
V_{DDQ}	Supply voltage flash I/O	$V_{SS} - 0.5$	2.5	V
V_{IN}	Input voltage on any digital pin (excluding FLASH input pins)	$V_{SS} - 0.5$	$V_{DDIO} + 0.3$	V
T_{stg}	Storage temperature	-55	+150	°C
T_{lead}	Lead temperature < 10s		+240	°C

2.2 Operating ranges

Operating ranges define the limits for functional operation and parametric characteristics of the device. Functionality outside these limits is not implied.

Table 2. Operating ranges

Symbol	Conditions	Min	Typ	Max	Unit
V_{DD}	Supply voltage baseband core and EMI pads	1.55	1.8	1.95	V
V_{DDF}	Supply voltage flash	1.55	1.8	1.95	V
V_{DDIO}	Supply voltage digital I/O	2.7	3.3	3.6	V
V_{DDQ}	Supply voltage flash I/O ($V_{DDQ} \leq V_{DDF}$)	1.55	1.8	1.95	V
T_{amb}	Operating ambient temperature	-40		+85	°C

2.3 I/O specifications

Depending on the interface, the I/O voltage is typical 1.8V (interface to the flash memory) or typical 3.3V (all the other interfaces). These I/Os comply with the EIA/JEDEC standard JESD8-B.

2.3.1 Specifications for 3.3V I/Os

Table 3. LVTTTL DC input specification ($3V < V_{DDIO} < 3.6V$)

Symbol	Parameter	Conditions	Min	Typ	Max	Unit
V_{il}	Low level input voltage				0.8	V
V_{ih}	High level input voltage		2			V
V_{hyst}	Schmitt trigger hysteresis		0.4			V

Table 4. LVTTTL DC output specification ($3V < V_{DDIO} < 3.6V$)

Symbol	Parameter	Conditions	Min	Typ	Max	Unit
V_{ol}	Low level output voltage	$I_{ol} = X \text{ mA}^{(1)}$			0.15	V
V_{oh}	High level output voltage	$I_{oh} = -X \text{ mA}^{(1)}$	$V_{DDIO} - 0.15$			V

1. X is the source/sink current under worst-case conditions according to the drive capability. (See [Table 8](#), pad information for value of X).

2.3.2 Specifications for 1.8V I/Os

Table 5. DC input specification ($1.55V < V_{DD} < 1.95V$)

Symbol	Parameter	Conditions	Min	Typ	Max	Unit
V_{il}	Low level input voltage				$0.35 \cdot V_{DD}$	V
V_{ih}	High level input voltage		$0.65 \cdot V_{DD}$			V
V_{hyst}	Schmitt trigger hysteresis		0.2	0.3	0.5	V

Table 6. DC Output Specification ($1.55V < V_{DD} < 1.95V$)

Symbol	Parameter	Conditions	Min	Typ	Max	Unit
V_{ol}	Low level output voltage	$I_{ol} = X \text{ mA}^{(1)}$			0.15	V
V_{oh}	High level output voltage	$I_{oh} = -X \text{ mA}^{(1)}$	$V_{DD} - 0.15$			V

1. X is the source/sink current under worst-case conditions according to the drive capability. (See [Table 8](#), pad information for value of X)

2.4 Current consumption

**Table 7. Typical power consumption of the E-STLC2416
(VDD = VDD Flash = PLLVDD = 1.8V, VDDIO = 3.3V)**

E-STLC2416 state	Core		IO	Unit
	Slave	Master		
Standby (no low power mode)	5.10	5.10	0.13	mA
Standby (low power mode enabled)	0.94	0.94	0.13	mA
ACL connection (no transmission)	7.60	6.99	0.13	mA
ACL connection (data transmission)	7.90	7.20	0.13	mA
SCO connection (no codec connected)	8.70	7.90	0.14	mA
Inquiry and Page scan (low power mode enabled)	127	n.a.	5	μA
Low Power mode (32 kHz crystal)	20	20	0	μA

3 Block diagram and electrical schematics

Figure 1. Block diagram and electrical schematic

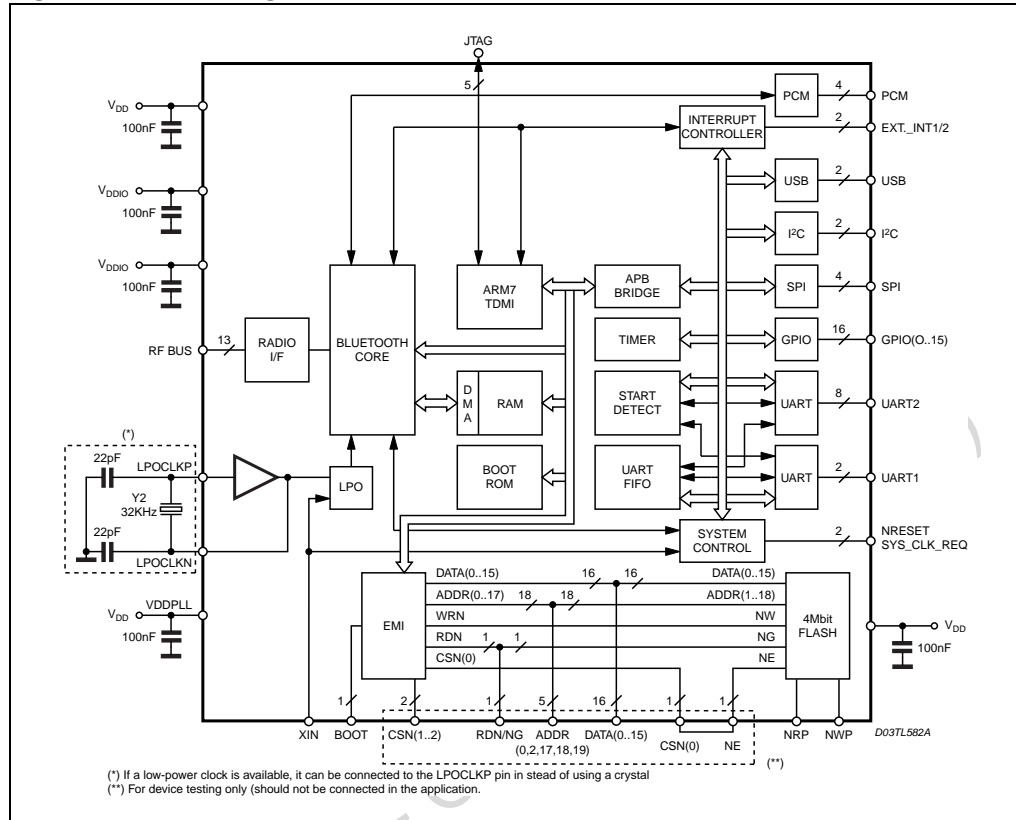

4 Pinout

Figure 2. Pin out (bottom view)

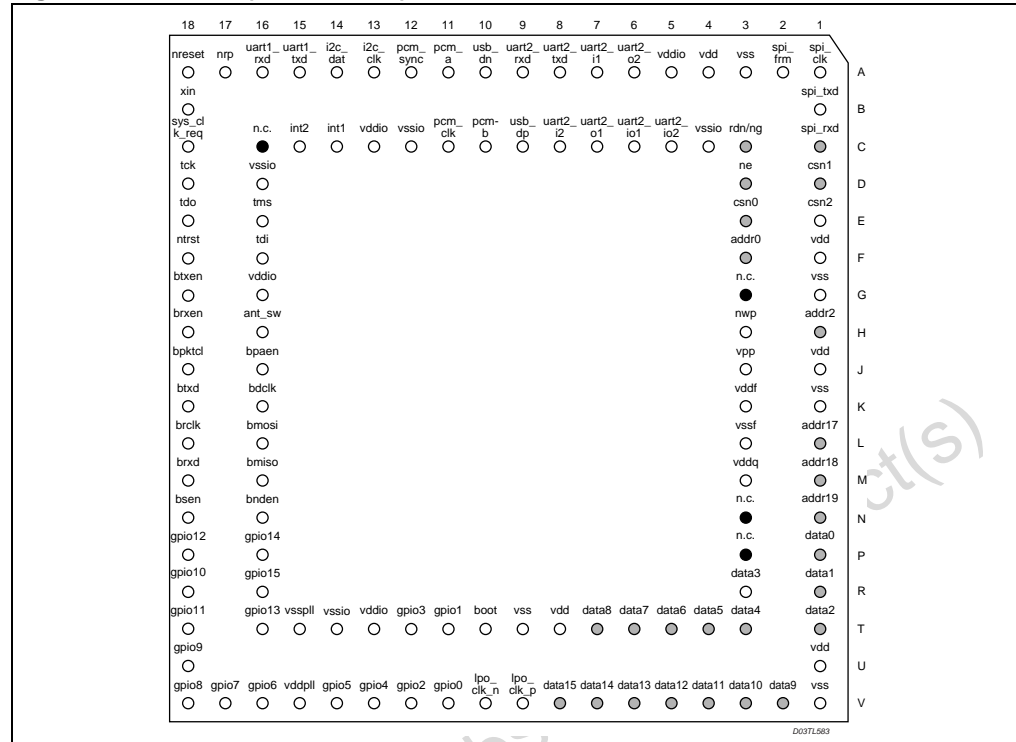

4.1 Pin description and assignment

Table 8 shows the pin list of the E-STLC2416. There are 91 functional pins of which 25 are used for device testing only (should not be connected in the application) and 24 supply pins. The column “PU/PD” shows the pads implementing an internal weak pull-up/down, to fix value if the pin is left open. This cannot replace an external pull-up/down.

The pads are grouped according to two different power supply values, as shown in column “VDD”:

- V1 for 3.3 V typical 2.7 - 3.6 V range
- V2 for 1.8 V typical 1.55 - 1.95 V range

Finally the column “DIR” describes the pin directions:

- I for Inputs
- O for Outputs
- I/O for Input/Outputs
- O/t for tri-state outputs

Table 8. E-STLC2416 pin list

Name	Pin #	Description	DIR	PU/PD	VDD	PAD
Clock and test pins						
xin	B18	System clock	I		V1	CMOS, 3.3V TTL compatible schmitt trigger
nreset	A18	Reset	I			
nrp	A17	Flash reset	I		V2	
nwp	H3	Flash Write Protect	I		V2	CMOS 1.8V
sys_clk_req	C18	System clock request	I/O		V1	CMOS, 3.3V TTL compatible, 2mA tri-state slew rate control
lpo_clk_p	V9	Low power oscillator + / Slow clock input	I	(1)	V2	
lpo_clk_n	V10	Low power oscillator -	O			
int1	C14	External Interrupt used also as external wake up	I	(1)	V1	CMOS, 3.3V TTL compatible schmitt trigger
int2	C15	Second external interrupt	I	(1)		
boot	T10	Select external boot from EMI or internal from ROM	I	(1)	V2	CMOS 1.8V
SPI interface						
spi_frm	A2	Synchronous Serial Interface frame sync	I/O		V1	CMOS, 3.3V TTL compatible, 2mA tri-state slew rate control schmitt trigger
spi_clk	A1	Synchronous Serial Interface clock	I/O			
spi_txd	B1	Synchronous Serial Interface transmit data	O/t		V1	CMOS, 3.3V TTL compatible, 2mA slew rate control
spi_rxd	C1	Synchronous Serial Interface receive data	I	(1)	V1	CMOS, 3.3V TTL compatible schmitt trigger
UART interface						
uart1_txd	A15	Uart1 transmit data	O/t		V1	CMOS, 3.3V TTL compatible, 2mA slew rate control
uart1_rxd	A16	Uart1 receive data	I	(2)	V1	CMOS, 3.3V TTL compatible schmitt trigger
uart2_o1	C7	Uart2 modem output	O		V1	CMOS, 3.3V TTL compatible, 2mA slew rate control
uart2_o2	A6	Uart2 modem output	O/t		V1	CMOS, 3.3V TTL compatible, 2mA slew rate control

Table 8. E-STLC2416 pin list (continued)

Name	Pin #	Description	DIR	PU/PD	VDD	PAD
uart2_i1	A7	Uart2 modem input	I	(2)	V1	CMOS, 3.3V TTL compatible
uart2_i2	C8	Uart2 modem input	I	(2)	V1	
uart2_io1	C6	Uart2 modem input/output	I/O	(2)	V1	CMOS, 3.3V TTL compatible, 2mA tri-state slew rate control
uart2_io2	C5	Uart2 modem input/output	I/O	(2)	V1	
uart2_txd	A8	Uart2 transmit data	O/t		V1	CMOS, 3.3V TTL compatible, 2mA slew rate control
uart2_rxd	A9	Uart2 receive data	I	(2)	V1	CMOS, 3.3V TTL compatible
I2C interface						
i2c_dat	A14	I2C data pin	I/O	(3)	V1	CMOS, 3.3V TTL compatible, 2mA tri-state slew rate control
i2c_clk	A13	I2C clock pin	I/O	(3)	V1	
USB interface						
usb_dn	A10	USB - pin (Needs a series resistor of 27 Ω \pm 5%)	I/O	(1)	V1	
usb_dp	C9	USB + pin (Needs a series resistor of 27 Ω \pm 5%)	I/O	(1)	V1	
GPIO interface						
gpio0	V11	Gpio port 0	I/O	PU	V1	CMOS, 3.3V TTL compatible, 4mA tri-state slew rate control
gpio1	T11	Gpio port 1	I/O	PU		
gpio2	V12	Gpio port 2	I/O	PU		
gpio3	T12	Gpio port 3	I/O	PU	V1	CMOS, 3.3V TTL compatible, 4mA tri-state slew rate control schmitt trigger
gpio4	V13	Gpio port 4	I/O	PU	V1	CMOS, 3.3V TTL compatible, 4mA tri-state slew rate control
gpio5	V14	Gpio port 5	I/O	PU		
gpio6	V16	Gpio port 6	I/O	PU		
gpio7	V17	Gpio port 7	I/O	PU		

Table 8. E-STLC2416 pin list (continued)

Name	Pin #	Description	DIR	PU/PD	VDD	PAD
gpio8	V18	Gpio port 8	I/O	PU	V1	CMOS, 3.3V TTL compatible, 2mA tri-state slew rate control
gpio9	U18	Gpio port 9	I/O	PU		
gpio10	R18	Gpio port 10	I/O	PU		
gpio11	T18	Gpio port 11	I/O	PU		
gpio12	P18	Gpio port 12	I/O	PU		
gpio13	T16	Gpio port 13	I/O	PU		
gpio14	P16	Gpio port 14	I/O	PU		
gpio15	R16	Gpio port 15	I/O	PU		
JTAG interface						
ntrst	F18	JTAG pin	I	PD	V1	CMOS, 3.3V TTL compatible
tck	D18	JTAG pin	I	(1)	V1	CMOS, 3.3V TTL compatible schmitt trigger
tms	E16	JTAG pin	I	PU	V1	CMOS, 3.3V TTL compatible
tdi	F16	JTAG pin	I	PU	V1	CMOS, 3.3V TTL compatible
tdo	E18	JTAG pin (should be left open)	O/t		V1	CMOS, 3.3V TTL compatible, 2mA slew rate control
PCM interface						
pcm_a	A11	PCM data	I/O	PD	V1	CMOS, 3.3V TTL compatible, 2mA tri-state slew rate control
pcm_b	C10	PCM data	I/O	PD		
pcm_sync	A12	PCM 8kHz sync	I/O	PD		
pcm_clk	C11	PCM clock	I/O	PD	V1	CMOS, 3.3V TTL compatible, 2mA tri-state slew rate control schmitt trigger
Radio interface						
brclk	L18	Transmit clock	I	(1)	V1	CMOS, 3.3V TTL compatible schmitt trigger
brxd	M18	Receive data	I			
bmiso	M16	RF serial interface input data	I	(1)	V1	CMOS, 3.3V TTL compatible

Table 8. E-STLC2416 pin list (continued)

Name	Pin #	Description	DIR	PU/PD	VDD	PAD
bnden	N16	RF serial interface control	O		V1	CMOS, 3.3V TTL compatible, 2mA slew rate control
bmosi	L16	RF serial interface output data	O			
bdclk	K16	RF serial interface clock	O			
btxd	K18	Transmit data	O			
bsen	N18	Synthesizer ON	O			
bpaen	J16	Open PLL	O			
brxen	H18	Receive ON	O			
btxen	G18	Transmit ON	O			
bpktctl	J18	Packet ON	O			
ant_sw	H16	Antenna switch	O		V1	CMOS, 3.3V TTL compatible, 8mA slew rate control

1. Should be strapped to vssio if not used.
2. Should be strapped to vddio if not used.
3. Must have a 10 kohm pull-up.

Table 9. E-STLC2416 pin list - Power supply

Name	Pin#	Description
vsspll	T15	PLL ground
vddpll	V15	1.8V supply for PLL
vdd	A4	1.8V Digital supply
vdd	F1	1.8V Digital supply
vdd	J1	1.8V Digital supply
vdd	U1	1.8V Digital supply
vdd	T8	1.8V Digital supply
vddf	K3	1.8V Digital supply Flash
vddq	M3	1.8V I/O's supply Flash
vpp	J3	12V fast program supply Flash
vddio	C13	3.3V I/O's supply
vddio	A5	3.3V I/O's supply
vddio	T13	3.3V I/O's supply
vddio	G16	3.3V I/O's supply
vss	A3	Digital ground
vss	G1	Digital ground
vss	K1	Digital ground
vss	V1	Digital ground

Table 9. E-STLC2416 pin list - Power supply (continued)

Name	Pin#	Description
vss	T9	Digital ground
vssf	L3	Digital ground Flash
vssio	C12	I/O's ground
vssio	C4	I/O's ground
vssio	T14	I/O's ground
vssio	D16	I/O's ground

Table 10. E-STLC2416 pin list (continued)

Name	Pin #	Description	DIR	PU/PD	VDD	PAD
To be connected together on the PCB						
ne	D3	Flash chip enable	I			
csn0	E3	External chip select bank 0	O			
Test only (do not connect)						
rdn/ng	C3	External read	O		V2	CMOS 1.8V 4 mA slew rate control
csn1	D1	External chip select bank 1	O			
csn2	E1	External chip select bank 2	O			
addr0	F3	External address bit 0	O			
addr2	H1	External address bit 2	O			
addr17	L1	External address bit 17	O			
addr18	M1	External address bit 18	O			
addr19	N1	External address bit 19	O			
data0	P1	External data bit 0	I/O	PD		
data1	R1	External data bit 1	I/O	PD		
data2	T1	External data bit 2	I/O	PD		
data3	R3	External data bit 3	I/O	PD		
data4	T3	External data bit 4	I/O	PD		
data5	T4	External data bit 5	I/O	PD		

Table 10. E-STLC2416 pin list (continued)

Name	Pin #	Description	DIR	PU/PD	VDD	PAD
data6	T5	External data bit 6	I/O	PD	V2	CMOS 1.8 V 4 mA slew rate control
data7	T6	External data bit 7	I/O	PD		
data8	T7	External data bit 8	I/O	PD		
data9	V2	External data bit 9	I/O	PD		
data10	V3	External data bit 10	I/O	PD		
data11	V4	External data bit 11	I/O	PD		
data12	V5	External data bit 12	I/O	PD		
data13	V6	External data bit 13	I/O	PD		
data14	V7	External data bit 14	I/O	PD		
data15	V8	External data bit 15	I/O	PD		
Not connected						
n.c.	C16, G3, N3, P3	Not connected				

5 Functional description

5.1 Baseband

WLAN coexistence. See also [Section 6.12: Bluetooth - WLAN coexistence in collocated scenario](#).

5.1.1 Baseband 1.1 features

The baseband is based on Ericsson Technology Licensing Baseband Core (EBC) and it is compliant with the Bluetooth specification 1.1:

- Point to multipoint (up to 7 slaves)
- Asynchronous Connection Less (ACL) link support giving data rates up to 721 kbps
- Synchronous Connection Oriented (SCO) link with support for 2 voice channels over the air interface.
- Flexible voice format to host and over the air (CVSD, PCM 13/16 bits, A-law, μ -law)
- HW support for packet types: DM1, 3, 5; DH1, 3, 5; HV1, 3; DV
- Scatternet capabilities (master in one piconet and slave in the other one; slave in two piconets). All scatternet v.1.1 errata supported.
- Ciphering support up to 128 bits key
- Paging modes R0, R1, R2
- Channel quality driven data rate
- Full Bluetooth software stack available
- Low level link controller

5.1.2 Baseband 1.2 features

The baseband part is also compliant with the Bluetooth specification 1.2:

- Extended SCO (eSCO) links: supports EV3 and EV5 packets. See also [Section 6.6: V1.2 detailed functionality - Extended SCO](#).
- Adaptive frequency hopping (AFH): hopping kernel, channel assessment as Master and as Slave. See also [Section 6.7: V1.2 detailed functionality - Adaptive frequency hopping](#).
- Faster connection: Interlaced scan for Page and Inquiry scan, answer FHS at first reception, RSSI used to limit range. See also [Section 6.8: V1.2 detailed functionality - Faster connection](#).
- QoS Flush. See also [Section 6.9: V1.2 detailed functionality - Quality of service](#).
- Synchronization: the local and the master BT clock are available via HCI commands for synchronization of parallel applications on different slaves
- L2CAP flow and error control
- LMP Improvements
- LMP SCO handling
- Parameter Ranges update

5.2 Integrated Flash memory

- 4 Mbit size
- 8 parameter blocks of 4 Kword (top configuration)
- 7 main blocks of 32 Kword
- 120 ns access time

Note: See the datasheet of the standalone product M28R400CT for more detailed information.

Figure 3. Block addresses

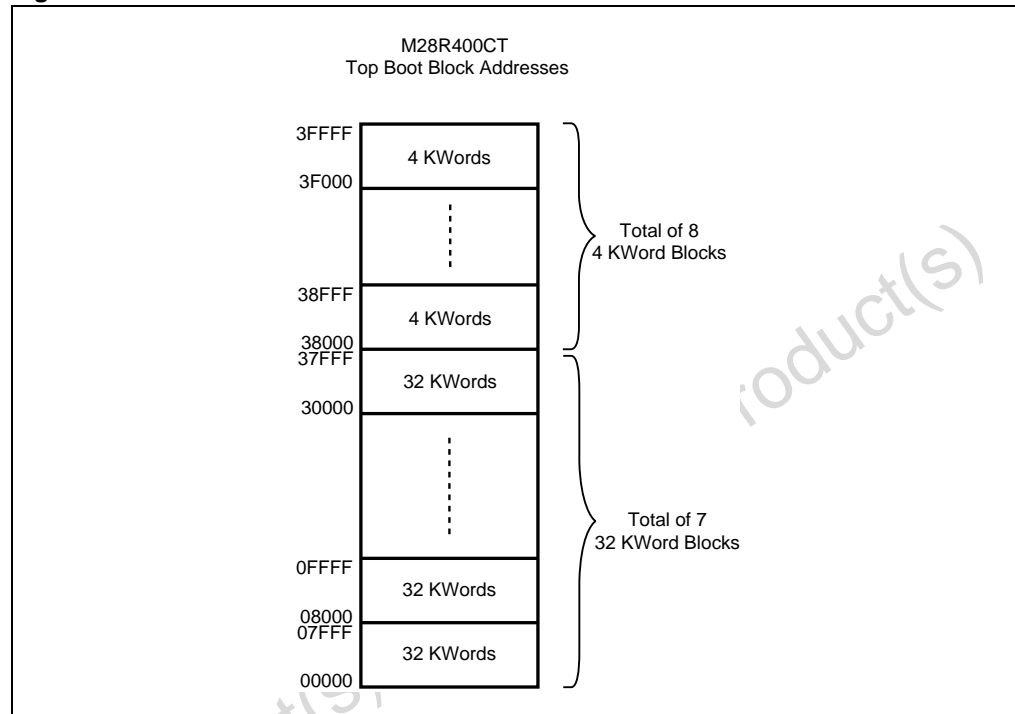

5.2.1 Flash signal descriptions

- **Write Protect (nwp)**
Write protect is an input that gives an additional hardware protection for each block. When Write Protect is $\leq 0.4V$ the Lock-Down is enabled and the protection status of the flash blocks cannot be changed. When Write Protect is $\geq (v_{ddq} - 0.4V)$, the Lock-Down is disabled and the flash memory blocks can be locked or unlocked.
- **Reset (nrp)**
The Reset input provides a hardware reset of the memory. When reset is $\leq 0.4V$, the memory is in reset mode: the outputs are high impedant and the current consumption is minimized. After Reset all blocks are in Locked state. When Reset is $\geq (v_{ddq} - 0.4V)$, the device is in normal operation. Exiting reset mode the device enters read array

mode, but a negative transition of Chip Enable or a change of the address is required to ensure valid data outputs.

- **Vdd Supply Voltage (vddf)**
Vdd provides the power supply to the internal core of the flash memory device. It is the main power supply for all operations (Read, Program and Erase)
- **Vddq Supply Voltage (vddq)**
Vddq provides the power supply to the I/O pins and enables all Outputs to be powered independently from Vddf. Vddq can be tied to Vddf or can use separate supply.
- **Vpp Program Supply Voltage (vpp)**
Vpp is both a control input and a power supply pin. The two functions are selected by the voltage range applied to the pin. The supply voltage Vddf and the program supply voltage Vpp can be applied in any order.
If Vpp is kept in a low voltage range (0V to 3.6V) Vpp is seen as a control input. In this case a voltage lower than 1V gives protection against program or block erase, while $1.65V < Vpp < 3.6V$ enables these functions. Vpp is only sampled at the beginning of a program or block erase; a change in its value after the operation has started does not have any effect and program or erase operations continue.
If Vpp is in the range 11.4V to 12.6V it acts as a power supply pin. In this condition Vpp must be stable until the Program/Erase algorithm is completed.
- **Vssf Flash Ground (vssf)**
Vssf is the reference for all voltage measurements.
- **Address Inputs (Addr0-Addr17), Data Input/Output (Data0-Data15), Chip Enable (csn0), Output Enable (rdn/ng), Write Enable (wrn)** are connected to and controlled by the Bluetooth™ baseband controller.

6 General specification

6.1 System clock

The E-STLC2416 works with a single clock provided on the XIN pin. The value of this external clock should be any integer value from 12 ... 33 MHz \pm 20ppm (overall).

6.1.1 Slow clock

The slow clock is used by the baseband as reference clock during the low power modes. The slow clock requires an accuracy of \pm 250ppm (overall).

Several options are foreseen in order to adjust the E-STLC2416 behavior according to the features of the radio used:

- If the system clock (e.g. 13MHz) is not provided at all times (power consumption saving) and no slow clock is provided by the system, a 32 kHz crystal must be used by the E-STLC2416 (default mode).
- If the system clock (e.g. 13MHz) is not provided at all times (power consumption saving) and the system provides a slow clock at 32kHz or 3.2kHz, this signal is simply connected to the E-STLC2416 (lpo_clk_p).
- If the system clock (e.g. 13MHz) is provided at all times, the E-STLC2416 generates from the reference clock an internal 32kHz clock. This mode is not an optimized mode for power consumption.

6.2 Boot procedure

The boot code instructions are the first that ARM7TDMI executes after a HW reset. All the internal device's registers are set to their default value.

There are 2 types of boot:

- Flash boot.

When boot pin is set to `1` (connected to VDD), the E-STLC2416 boots on its flash

- UART download boot from ROM.

When boot pin is set to `0` (connected to GND), the E-STLC2416 boots on its internal ROM (needed to download the new firmware in the flash). When booting on the internal ROM, the E-STLC2416 will monitor the UART interface for approximately 1.4 second. If there is no request for code downloading during this period, the ROM jumps to flash.

6.3 Clock detection

The E-STLC2416 has an automatic slow clock frequency detection (32kHz, 3.2kHz or none).

6.4 Master reset

When the device's reset is held active (nreset is low), uart1_txd and uart2_txd are set to input state. When the nreset returns high, the device starts to boot.

Note: The device should be held in active reset for minimum 20ms in order to guarantee a complete reset of the device.

6.5 Interrupts/wake-up

All GPIOs can be used both as external interrupt source and as wake-up source. In addition the device can be woken-up by USB, uart1_rxd, uart2_rxd, int1, int2.

6.6 V1.2 detailed functionality - Extended SCO

- User Perspective - Extended SCO

This function gives improved voice quality since it enables the possibility to retransmit lost or corrupted voice packets in both directions.

- Technical perspective - Extended SCO

eSCO incorporates CRC, negotiable data rate, negotiable retransmission window and multi-slot packets. Retransmission of lost or corrupted packets during the retransmission window guarantees on-time delivery.

Figure 4. Extended eSCO

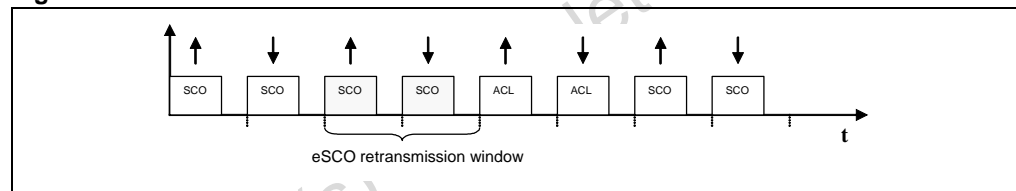

6.7 V1.2 detailed functionality - Adaptive frequency hopping

- User perspective - Adaptive frequency hopping

In the Bluetooth spec 1.1 the Bluetooth devices hop in the 2.4 GHz band over 79-channels. Since WLAN 802.11 has become popular, there are specification improvements in the 1.2-SIG spec for Bluetooth where the Bluetooth units can avoid the jammed bands and thereby provide an improved co-existence with WLAN.

- Technical perspective - Adaptive frequency hopping

Figure 5. AFH

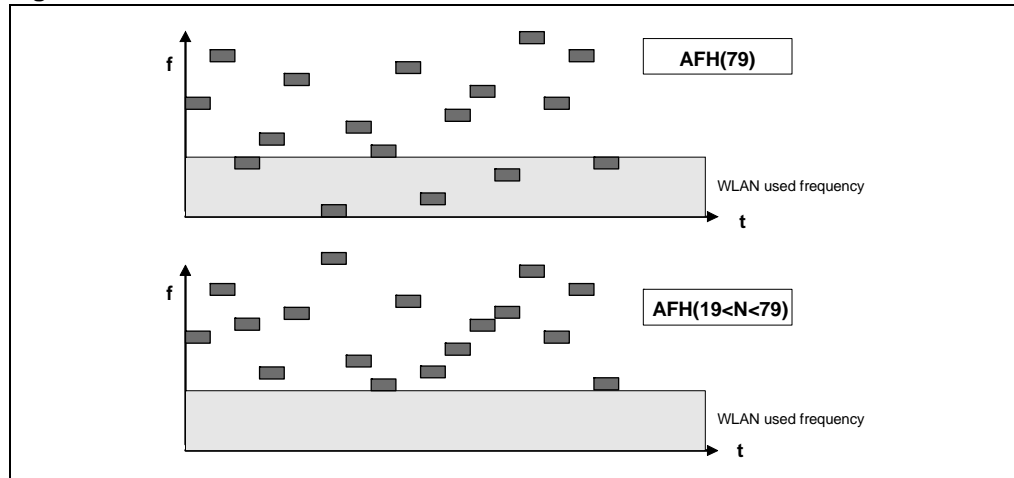

First the Master and/or the Slaves identify the jammed channels. The Master decides on the channel distribution and informs the involved slaves. The Master and the Slaves, at a predefined instant, switch to the new channel distribution scheme.

No longer jammed channels are re-inserted into the channel distribution scheme. AFH uses the same hop frequency for transmission as for reception

6.8 V1.2 detailed functionality - Faster connection

- User perspective - Faster connection

This feature gives the User about 65% faster connection on average when enabled compared to Bluetooth spec 1.1 connection procedure.

- Technical perspective - Faster connection

The faster Inquiry functionality is based on a removed/shortened random back off and also a new Interlaced Inquiry scan scheme.

The faster Page functionality is based on Interlaced Page Scan.

6.9 V1.2 detailed functionality - Quality of service

User perspective - Quality of service

Small changes to the BT1.1 spec regarding Quality of Service makes a large difference by allowing all QoS parameters to be communicated over HCI to the link manager that enables efficient BW management. Here after a short list of user perspectives:

1. Flush time-out: enables time-bounded traffic such as video streaming to become more robust when the channel degrades. It sets the maximum delay of an L2CAP frame. It does not enable multiple streams in one piconet, or heavy data transfer at the same time.
2. Simple latency control: allows the host to set the poll interval. Provides enough support for HID devices mixed with other traffic in the piconet.

6.10 Low power modes

To save power, two low power modes are supported. Depending of the Bluetooth and of the Host's activity, the E-STLC2416 autonomously decides to use Sleep Mode or Deep Sleep Mode.

Table 11. Low power modes

Low power mode	Description
Sleep mode	<p>The E-STLC2416:</p> <ul style="list-style-type: none"> - Accepts HCI commands from the Host. - Supports page- and inquiry scans. - Supports Bluetooth links that are in Sniff, Hold or Park. - Can transfer data over Bluetooth links. - The system clock is still active in part of the design.
Deep sleep mode	<p>The E-STLC2416:</p> <ul style="list-style-type: none"> - Does not accept HCI commands from the Host. - Keeps track of page- and inquiry scan activities. - Switches between sleep and active mode when it is time to scan. - Supports Bluetooth links that are in Sniff, Hold or Park. - Does not transfer data over Bluetooth links. - The system clock is not active in any part of the design. <p>Note: Deep Sleep mode is not compatible with a USB transport layer.</p>

Some examples of the low power modes usage:

6.10.1 Sniff or park

The E-STLC2416 is in active mode with a Bluetooth connection, once the connection is concluded the SNIFF or the PARK is programmed. Once one of these two states is entered the E-STLC2416 goes in Sleep Mode. After that, the Host may decide to place the E-STLC2416 in Deep Sleep Mode by putting the UART LINK in low power mode. The Deep Sleep Mode allows smaller power consumption. When the E-STLC2416 needs to send or receive a packet (e.g. at T_{SNIFF} or at the beacon instant) it will require the clock and it will go in active mode for the needed transmission/reception. Immediately afterwards it will go back to the Deep Sleep Mode. If some HCI transmission is needed, the UART link will be reactivated, using one of the two ways explained in 7.5, and the E-STLC2416 will move from the Deep Sleep Mode to the Sleep Mode.

6.10.2 Inquiry/page scan

When only inquiry scan or page scan is enabled, the E-STLC2416 will go in Sleep Mode or Deep Sleep Mode outside the receiver activity. The selection between Sleep Mode and Deep Sleep Mode depend on the UART activity like in SNIFF or PARK.

6.10.3 No connection

If the Host places the UART in low power and there is no activity, then the E-STLC2416 can be placed in Deep Sleep Mode.

6.10.4 Active link

When there is an active link (SCO or ACL), the E-STLC2416 cannot go in Deep Sleep Mode whatever the UART state is. But the E-STLC2416 baseband is made such that whenever it is possible, depending on the scheduled activity (number of link, type of link, amount of data exchanged), it goes in Sleep Mode.

6.11 SW initiated low power mode

A wide set of wake up mechanisms are supported.

6.12 Bluetooth - WLAN coexistence in collocated scenario

The coexistence interface uses 4 GPIO pins, when enabled.

Bluetooth and WLAN 802.11 b/g technologies occupy the same 2.4 GHz ISM band. E-STLC2416 implements a set of mechanisms to avoid interference in a collocated scenario.

The E-STLC2416 supports 5 different algorithms in order to provide efficient and flexible simultaneous functionality between the two technologies in collocated scenarios:

- **Algorithm 1:** PTA (Packet Traffic Arbitration) based coexistence algorithm defined in accordance with the IEEE 802.15.2 recommended practice.
- **Algorithm 2:** the WLAN is the master and it indicates to the E-STLC2416 when not to operate in case of simultaneous use of the air interface.
- **Algorithm 3:** the E-STLC2416 is the master and it indicates to the WLAN device when not to operate in case of simultaneous use of the air interface.
- **Algorithm 4:** Two-wire mechanism
- **Algorithm 5:** Alternating Wireless Medium Access (AWMA), defined in accordance with the WLAN 802.11 b/g technologies.

The algorithm is selected via HCI command. The default algorithm is algorithm 1.

6.12.1 Algorithm 1: PTA (Packet Traffic Arbitration)

The Algorithm is based on a bus connection between the E-STLC2416 and the WLAN device.

Figure 6. Bus connection between the E-STLC2416 and the WLAN device

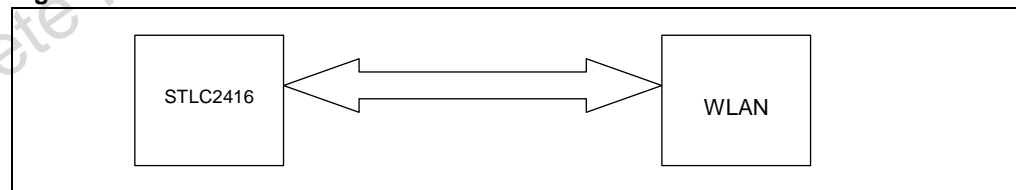

By using this coexistence interface it's possible to dynamically allocate bandwidth to the two devices when simultaneous operations are required while the full bandwidth can be allocated to one of them in case the other one does not require activity. The algorithm involves a priority mechanism, which allows preserving the quality of certain types of link. A typical application would be to guarantee optimal quality to the Bluetooth voice communication while an intensive WLAN communication is ongoing.

Several algorithms have been implemented in order to provide a maximum of flexibility and efficiency for the priority handling. Those algorithms can be activated via specific HCI commands.

The combination of a time division multiplexing techniques to share the bandwidth in case of simultaneous operations and of the priority mechanism avoid the interference due to packet collision and it allows the maximization of the 2.4 GHz ISM bandwidth usage for both devices while preserving the quality of some critical types of link.

6.12.2 Algorithm 2: WLAN master

In case the E-STLC2416 has to cooperate, in a collocated scenario, with a WLAN device not supporting a PTA based algorithm, it is possible to put in place a simpler mechanism.

The interface is reduced to 1 line:

Figure 7. Algorithm 2 - WLAN master

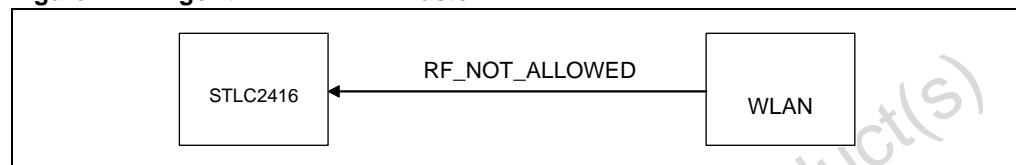

When the WLAN has to operate, it alerts RF_NOT_ALLOWED signal and the E-STLC2416 does not operate while this signal remains HIGH.

This mechanism permits to avoid packet collision in order to make an efficient use of the bandwidth but cannot provide guaranteed quality over the Bluetooth links.

6.12.3 Algorithm 3: Bluetooth master

This algorithm represents the symmetrical case of [Section 6.12.2](#). Also in this case the interface is reduced to 1 line.

Figure 8. Algorithm 3 - Bluetooth master

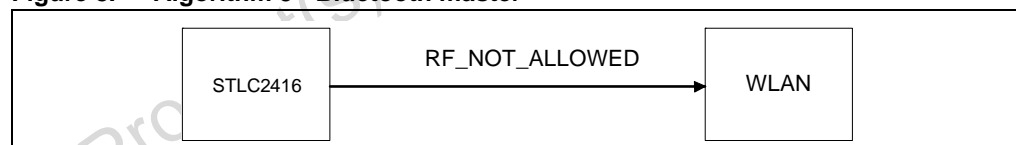

When the E-STLC2416 has to operate it alerts HIGH the RF_NOT_ALLOWED signal and the WLAN will not operate while this signals stays HIGH.

This mechanism permits to avoid packet collision in order to make an efficient use of the bandwidth, it provides high quality for all Bluetooth links but cannot provide guaranteed quality over the WLAN links.

6.12.4 Algorithm 4: two-wire mechanism

Based on algorithm 2 and 3, the Host decides, on a case-by-case basis, whether WLAN or Bluetooth is master.

6.12.5 Algorithm 5: alternating wireless medium access (AWMA)

AWMA utilizes a portion of the WLAN beacon interval for Bluetooth operations. From a timing perspective, the medium assignment alternates between usage following WLAN procedures and usage following Bluetooth procedures.

The timing synchronization between the WLAN and the E-STLC2416 is done by the HW signal MEDIUM_FREE.

Table 12. WLAN HW signal assignment

WLAN	Scenario 1: PTA	Scenario 2: WLAN master	Scenario 3: BT master	Scenario 4: 2-wire	Scenario 5: AWMA
WLAN 1	TX_CONFIRM	BT_RF_NOT_ALLOWED	Not used	BT_RF_NOT_ALLOWED	MEDIUM_FREE
WLAN 2	TX_REQUEST	Not used	WLAN_RF_NOT_ALLOWED	WLAN_RF_NOT_ALLOWED	Not used
WLAN 3	STATUS	Not used	Not used	Not used	Not used
WLAN 4	OPTIONAL_SIGNAL	Not used	Not used	Not used	Not used

7 Interfaces

7.1 UART Interface

The device contains two enhanced (128 byte transmit FIFO and 128 byte receive FIFO, sleep mode, 127 Rx and 128 Tx interrupt thresholds) UARTs named UART1 and UART2 compatible with the standard M16550 UART.

For UART1, only Rx and Tx signals are available (used for debug purposes).

UART2 features:

- standard HCI UART transport layer:
 - all HCI commands as described in the Bluetooth™ specification 1.1
 - ST specific HCI command (check E-STLC2416 Software Interface document for more information)
- RXD, TXD, CTS, RTS on permanent external pins
- 128-byte FIFOs, for transmit and for receive
- Default configuration: 57.600 kbps
- Specific HCI command to change to the following baud rates:

Table 13. List of supported baud rates

Baud rate		
–	57.600 kbps (default)	4800
921.6k	38.4 k	2400
460.8 k	28.8 k	1800
230.4 k	19.2 k	1200
153.6 k	14.4 k	900
115.2 k	9600	600
76.8 k	7200	300

7.2 Synchronous serial interface

The Synchronous Serial Interface (SSI) (or the Synchronous Peripheral Interface (SPI)) is a flexible module supporting full-duplex and half-duplex synchronous communications with external devices in Master and Slave mode. It enables a microcontroller unit to communicate with peripheral devices or allows inter-processor communications in a multiple-master environment. This Interface is compatible with the Motorola SPI standard, with the Texas Instruments Synchronous Serial frame format and with National Semiconductor Microwire standard.

Special extensions are implemented to support the Agilent SPI interface for optical mouse applications and the 32 bit data SPI for stereo codec applications.

7.2.1 Feature description: Agilent mode

One application is a combination of a Bluetooth device with an AGILENT optical mouse sensor to build a Bluetooth Mouse. The AGILENT device has an SPI interface with one bi-directional data port.

When spi_io from ADNS_2030 is driving, spi_rxd should be active, while spi_txd is set as a tri-state high impedance input.

For a read operation, the Bluetooth spi_txd is put in high impedance state after the reception of the address.

Note that this feature works independently of the SPI mode, supporting other combinations.

In this case, the devices are connected as described in the figure below.

Figure 9. Agilent mode

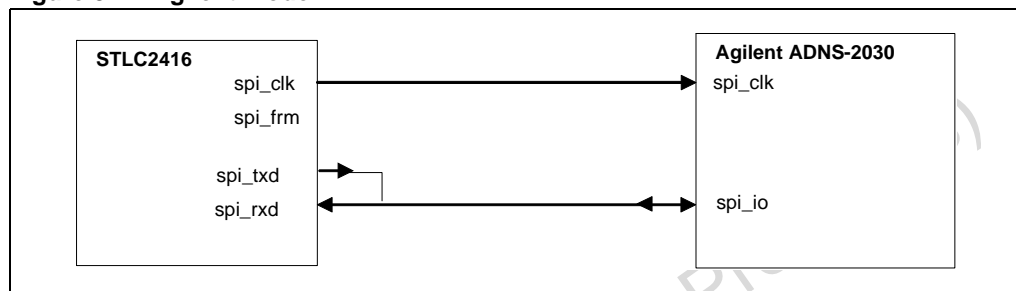

7.2.2 Feature description: 32-bit SPI

One application is a Bluetooth stereo headset. In this application, the audio samples are received from the emitter through the air using the Bluetooth baseband with ACL packets. The samples are decoded by the embedded ARM CPU (the samples were encoded, for compression, in SBC or MP3 format) and then sent to a stereo codec through the SPI interface. The application is described in the figure below.

Figure 10. 32-bit SPI

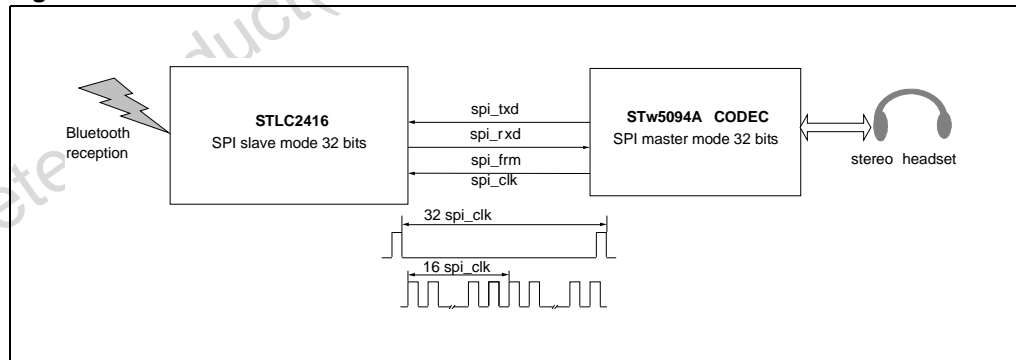

To support this application, the data size is 32 bits. The 32 bits support is implemented for both transmit and receive.

7.3 I2C interface

Used to access I2C peripherals.

The interface is a fast master I2C; it has full control of the interface at all times. I2C slave functionality is not supported.

7.4 USB interface

The USB interface is compliant with the USB 2.0 full speed specification. Max throughput on the USB interface is 12 Mbit/s.

Figure 11 gives an overview of the main components needed for supporting the USB interface, as specified in the Bluetooth™ Core Specification. For clarity, the serial interface (including the UART Transport Layer) is also shown.

Figure 11. USB interface

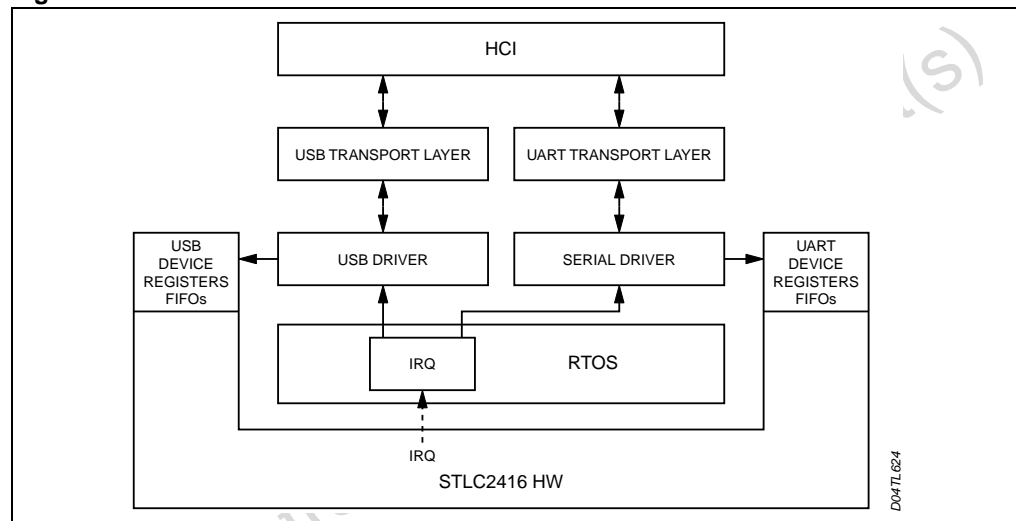

The USB device registers and FIFOs are memory mapped. The USB Driver will use these registers to access the USB interface. The equivalent exists for the HCI communication over UART.

For transmission to the host, the USB and Serial Drivers interface with the HW via a set of registers and FIFOs, while in the other direction, the hardware may trigger the Drivers through a set of interrupts (identified by the RTOS, and directed to the appropriate Driver routines).

7.5 JTAG Interface

The JTAG interface is compliant with the JTAG IEEE Std 1149.1. It allows both the boundary scan of the digital pins and the debug of the ARM7TDMI application when connected with the standard ARM7 development tools.

7.6 RF Interface

The E-STLC2416 radio interface is compatible to BlueRF (unidirectional RxMode2 for data and unidirectional serial interface for control).

7.7 PCM voice interface

The voice interface is a direct PCM interface to connect to a standard CODEC (e.g. STw5093 or STw5094) including internal decimator and interpolator filters. The data can be linear PCM (13-16bit), μ -Law (8bit) or A-Law (8bit). By default the codec interface is configured as master. The encoding on the air interface is programmable to be CVSD, A-Law or μ -Law.

The PCM block is able to manage the PCM bus with up to 3 time slots.

In master mode, PCM clock and data can operate at 2 MHz or at 2.048 MHz to allow interfacing of standard codecs.

The four signals of the PCM interface are:

- PCM_CLK: PCM clock
- PCM_SYNC: PCM 8kHz sync
- PCM_A: PCM data
- PCM_B: PCM data

Directions of PCM_A and PCM_B are software configurable.

Three additional PCM_SYNC signals can be provided via the GPIOs. See [Chapter 7: Interfaces](#) for more details.

Figure 12. PCM (A-law, μ -law) standard mode

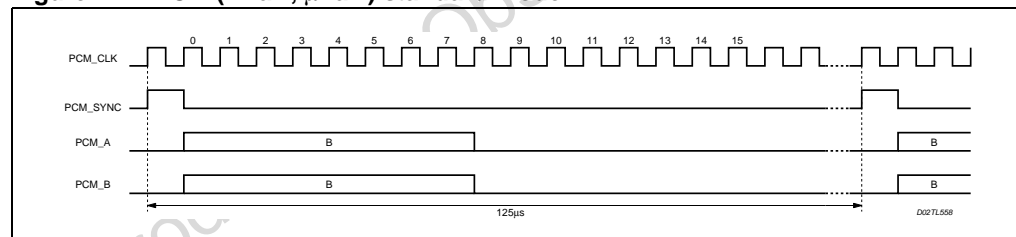

Figure 13. Linear mode

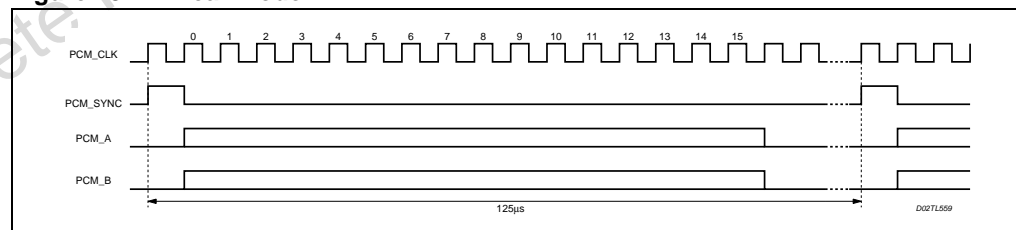
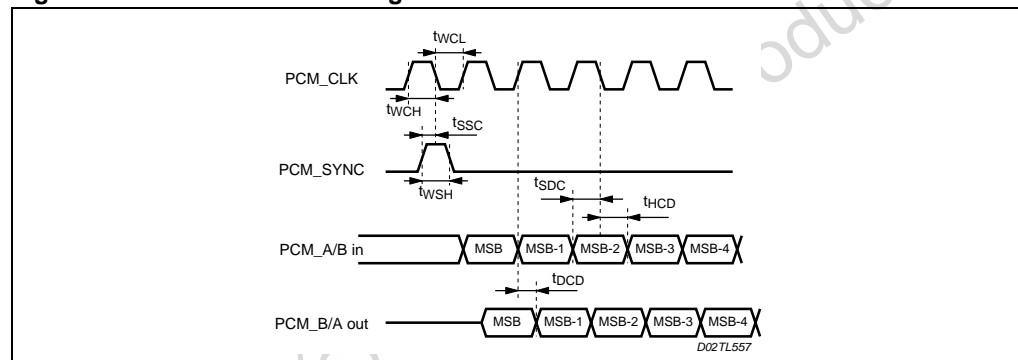

Table 14. PCM interface timing

Symbol	Description	Min	Typ	Max	Unit
$F_{\text{pcm_clk}}$	Frequency of PCM_CLK (master)		2048		kHz
$F_{\text{pcm_sync}}$	Frequency of PCM_SYNC		8		kHz
t_{WCH}	High period of PCM_CLK	200			ns
t_{WCL}	Low period of PCM_CLK	200			ns
t_{WSH}	High period of PCM_SYNC	200			ns
t_{SSC}	Setup time, PCM_SYNC high to PCM_CLK low	100			ns
t_{SDC}	Setup time, PCM_A/B input valid to PCM_CLK low	100			ns
t_{HCD}	Hold time, PCM_CLK low to PCM_A/B input invalid	100			ns
t_{DCD}	Delay time, PCM_CLK high to PCM_A/B output valid			150	ns

Figure 14. PCM interface timing

8 HCI UART transport layer

The UART Transport Layer has been specified by the Bluetooth™ SIG, and allows HCI level communication between a host controller (E-STLC2416) and a host (e.g. PC), via a serial line.

The objective of this HCI UART Transport Layer is to make it possible to use the Bluetooth™ HCI over a serial interface between two UARTs on the same PCB. The HCI UART Transport Layer assumes that the UART communication is free from line errors.

8.1 UART settings

The HCI UART Transport Layer uses the following settings for RS232:

- Baud rate: configurable (default baud rate: 57.600 kbps)
- Number of data bits: 8
- Parity bit: no parity
- Stop bit: 1 stop bit
- Flow control: RTS/CTS
- Flow-off response time: 3 ms

Flow control with RTS/CTS is used to prevent temporary UART buffer overrun. It should not be used for HCI flow control, since HCI has its own flow control mechanisms for HCI commands, HCI events and HCI data.

If CTS equals 1, then the Host/Host Controller is allowed to send.

If CTS equals 0, then the Host/Host Controller is not allowed to send.

The flow-off response time defines the maximum time from setting RTS low until the byte flow actually stops. The signals should be connected in a null-modem fashion; i.e. the local TXD should be connected to the remote RXD and the local RTS should be connected to the remote CTS and vice versa.

Figure 15. UART transport layer

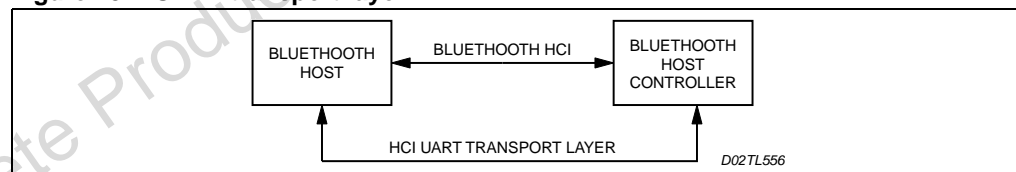

9 HCI USB transport layer

The USB Transport Layer has been specified by the Bluetooth™ SIG, and allows HCI level communication between a host controller (E-STLC2416) and a host (e.g. PC), via a USB interface. The USB Transport Layer is completely implemented in SW. It accepts HCI messages from the HCI Layer, prepares it for transmission over a USB bus, and sends it to the USB Driver. It reassembles the HCI messages from USB data received from the USB Driver, and sends these messages to the HCI Layer. The Transport Layer does not interpret the contents (payload) of the HCI messages; it only examines the header.

Obsolete Product(s) - Obsolete Product(s)

10 Class1 power support

The device can control an external power amplifier (PA). Several signals are duplicated on GPIOs for this purpose in order to avoid digital/analogue noise loops in the radio.

A software controlled register enables the alternate functions of GPIO[15:6] to generate the signals for driving an external PA in a Bluetooth™ class1 power application.

Every bit enables a dedicated signal on a GPIO pin, as described in [Table 15](#).

Table 15. GPIOs

Involved GPIO	Description
gpio0	No dedicated function
gpio1	WLAN 1
gpio2	WLAN 2
gpio3	WLAN 3
gpio4	WLAN 4
gpio5	(Used for USB reset pull.)
gpio6	Power Class 1 rxon
gpio7	Power Class 1 not_rxon
gpio8	Power Class 1 PA0 or PCM sync 1
gpio9	Power Class 1 PA1 or PCM sync 2
gpio10	Power Class 1 PA2 or PCM sync 3
gpio11	Power Class 1 PA3
gpio12	Power Class 1 PA4
gpio13	Power Class 1 PA5
gpio14	Power Class 1 PA6
gpio15	Power Class 1 PA7

rx_on is the same as the rx_on output pin. Not rx_on is the inverted signal, in order to save components on the application board.

PA7 to PA0 are the power amplifier control lines. They are managed, on a connection basis, by the baseband core. The Power Level programmed for a certain Bluetooth™ connection is managed by the firmware, as specified in the Bluetooth™ SIG spec.

11 Package mechanical data

In order to meet environmental requirements, ST offers these devices in ECOPACK® packages. These packages have a Lead-free second level interconnect. The category of second Level Interconnect is marked on the package and on the inner box label, in compliance with JEDEC Standard JESD97. The maximum ratings related to soldering conditions are also marked on the inner box label. ECOPACK is an ST trademark. ECOPACK specifications are available at: www.st.com.

Figure 16. LFBGA120 mechanical data and package dimensions

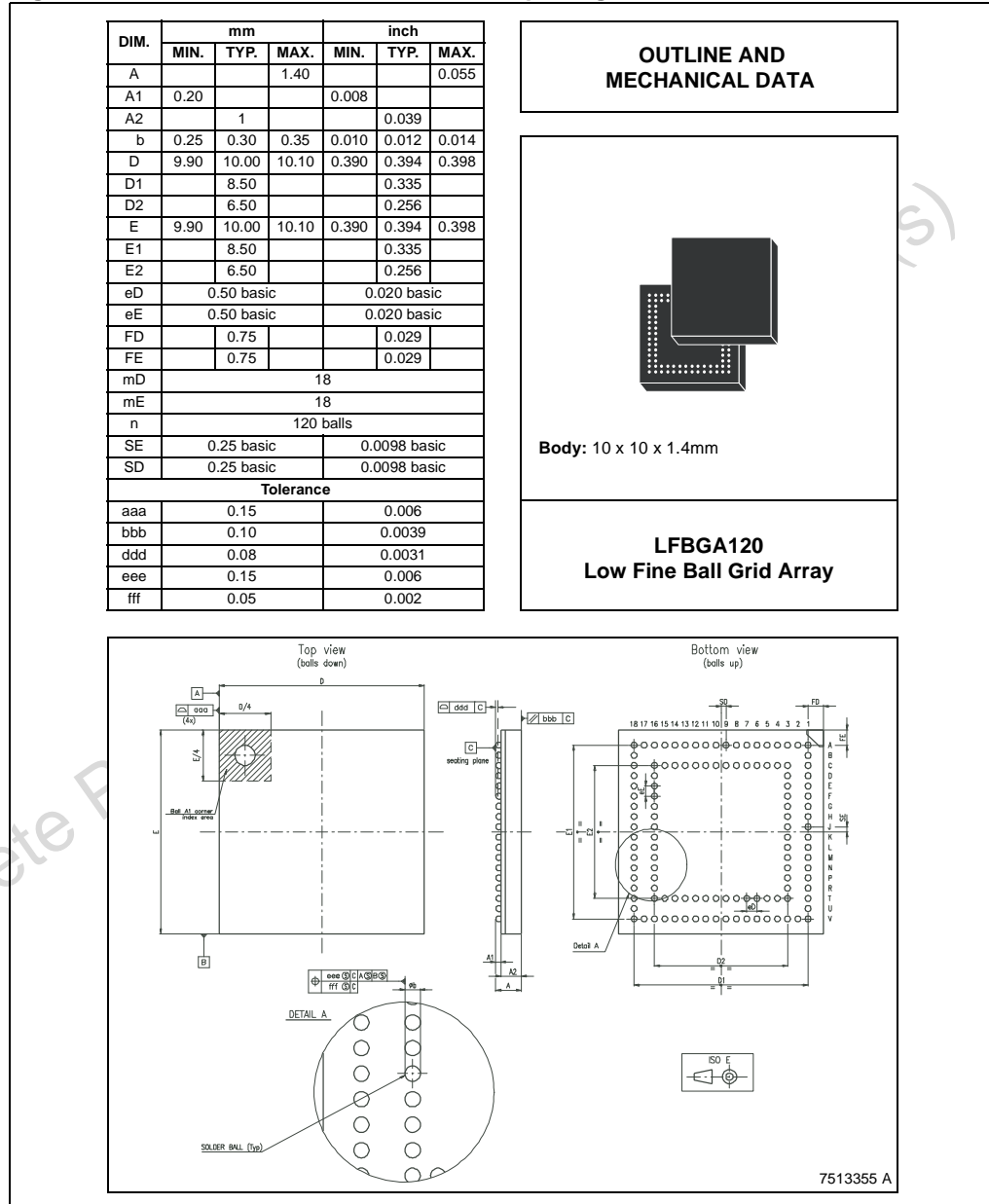

12 Ordering information

Table 16. Order codes

Part Number	Package	Temp. Range
E-STLC2416	LFBGA120 (lead free)	-40 to +85 °C

13 Revision history

Table 17. Document revision history

Date	Revision	Changes
20-Nov-2006	1	Initial release.
03-Oct-2008	2	Updated the document status to 'Not recommended for new design'. Applied ST-NXP Wireless template. No change in the content.

Please Read Carefully:

Information in this document is provided solely in connection with ST-NXP products. ST-NXP Wireless NV and its subsidiaries ("ST-NXP") reserve the right to make changes, corrections, modifications or improvements, to this document, and the products and services described herein at any time, without notice.

All ST-NXP products are sold pursuant to ST-NXP's terms and conditions of sale.

Purchasers are solely responsible for the choice, selection and use of the ST-NXP products and services described herein, and ST-NXP assumes no liability whatsoever relating to the choice, selection or use of the ST-NXP products and services described herein. No license, express or implied, by estoppel or otherwise, to any intellectual property rights is granted under this document. If any part of this document refers to any third party products or services it shall not be deemed a license grant by ST-NXP for the use of such third party products or services, or any intellectual property contained therein or considered as a warranty covering the use in any manner whatsoever of such third party products or services or any intellectual property contained therein.

UNLESS OTHERWISE SET FORTH IN ST-NXP'S TERMS AND CONDITIONS OF SALE ST-NXP DISCLAIMS ANY EXPRESS OR IMPLIED WARRANTY WITH RESPECT TO THE USE AND/OR SALE OF ST-NXP PRODUCTS INCLUDING WITHOUT LIMITATION IMPLIED WARRANTIES OF MERCHANTABILITY, FITNESS FOR A PARTICULAR PURPOSE (AND THEIR EQUIVALENTS UNDER THE LAWS OF ANY JURISDICTION), OR INFRINGEMENT OF ANY PATENT, COPYRIGHT OR OTHER INTELLECTUAL PROPERTY RIGHT.

UNLESS EXPRESSLY APPROVED IN WRITING BY AN AUTHORIZED ST-NXP REPRESENTATIVE, ST-NXP PRODUCTS ARE NOT RECOMMENDED, AUTHORIZED OR WARRANTED FOR USE IN MILITARY, AIR CRAFT, SPACE, LIFE SAVING, OR LIFE SUSTAINING APPLICATIONS, NOR IN PRODUCTS OR SYSTEMS WHERE FAILURE OR MALFUNCTION MAY RESULT IN PERSONAL INJURY, DEATH, OR SEVERE PROPERTY OR ENVIRONMENTAL DAMAGE. ST-NXP PRODUCTS WHICH ARE NOT SPECIFIED AS "AUTOMOTIVE GRADE" MAY ONLY BE USED IN AUTOMOTIVE APPLICATIONS AT USER'S OWN RISK.

Resale of ST-NXP products with provisions different from the statements and/or technical features set forth in this document shall immediately void any warranty granted by ST-NXP for the ST-NXP product or service described herein and shall not create or extend in any manner whatsoever, any liability of ST-NXP.

ST-NXP and the ST-NXP logo are trademarks or registered trademarks of ST-NXP in various countries.

Information in this document supersedes and replaces all information previously supplied.

The ST-NXP logo is a registered trademark of ST-NXP Wireless. All other names are the property of their respective owners.



© 2008 ST-NXP Wireless - All rights reserved

ST-NXP Wireless group of companies

Belgium - Brazil - Canada - China - Czech Republic - Finland - France - Germany - India - Italy - Japan - Korea - Malaysia - Mexico - Netherlands - Singapore - Sweden - Switzerland - Taiwan - United Kingdom - United States of America

www.stnwireless.com