

TOSHIBA RF Power Amplifier Module

S-AV10L,S-AV10H

VHF RF Power Amplifier Module

Unit: mm

- High gain: $P_o \geq 14\text{ W}$, $G_p \geq 1.85\text{dB}$, $\eta_T \geq 40\%$
- S-AV10L 135~155 MHz
- S-AV10H 150~175 MHz

Maximum Ratings (Tc = 25°C)

Characteristics	Symbol	Rating	Unit
DC supply voltage	V _{CC}	16	V
DC supply voltage	V _{CON}	16	V
Input power	P _i	300	mW
Operating case temperature range	T _{c (opr)}	-30~100	°C
Storage temperature range	T _{stg}	-40~110	°C

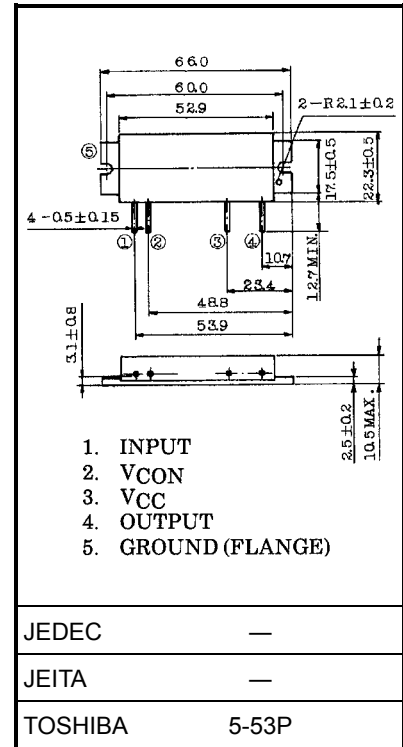

Electrical Characteristics (Tc = 25°C)

Weight: 35 g (typ.)

Characteristics	Symbol	Test Condition	Min	Typ.	Max	Unit
Frequency range	f _{range}	—	135	—	175	MHz
Output power	P _o	P _i = 200 mW V _{CC} = 12.5 V, V _{CON} = 12.5 V Z _G = Z _L = 50 Ω	14	—	—	W
Power gain	G _p		18.5	—	—	dB
Total efficiency	η _T		40	—	—	%
Input VSWR	VSWR _{in}		—	—	2	—
Harmonics	HRM		—	—	-25	dB
Load mismatch	—		V _{CC} = 15 V, V _{CON} = 12.5 V P _o = 15 W (P _i = adjust) VSWR load 20: 1 all phase	No degradation		
Power slump	—	T _c = -30~80°C V _{CC} = 12.5 V, P _i = 200 mW P _o = 14 W (@T _c = 25°C)	—	0.8	—	dB
Stability	—	V _{CC} = 12.5 V, P _i = 200 mW V _{CON} = 0~12.5 V VSWR Load 3: 1 all phase	All spurious output than 60dB below desired signal			—

Caution

This product has intersetting cap. Please pay attention for exceeding stress and foreign matter in your application. And not to take away the cap.

Beryllia Ceramics is used in this product. The dust or vapor can be dangerous to humans. Do not break, cut, crush or dissolve chemically. Dispose of this product properly according to law. Do not intermingle with normal industrial or domestic waste.

Schematic

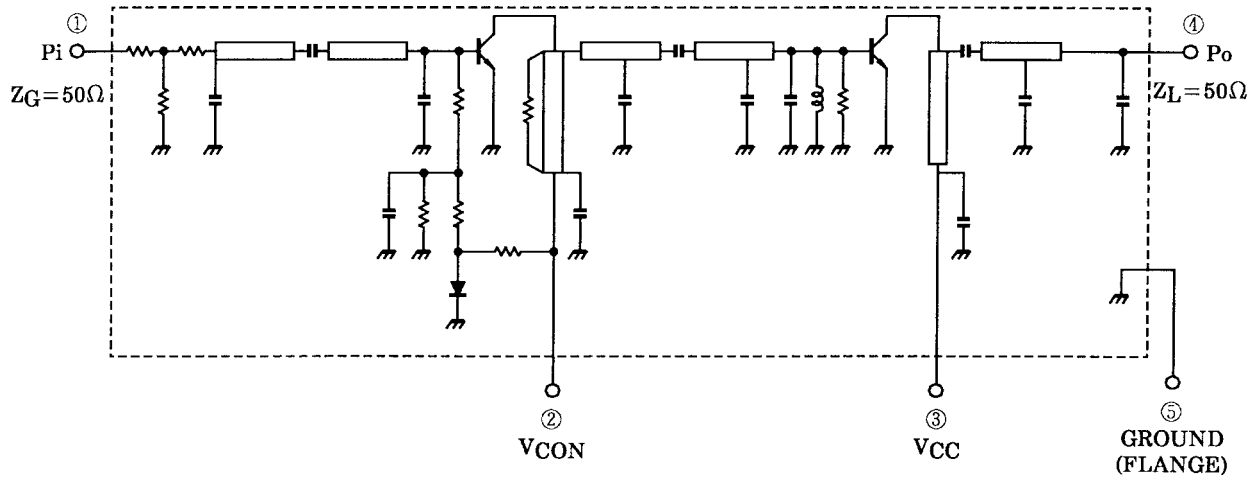

Test Fixture

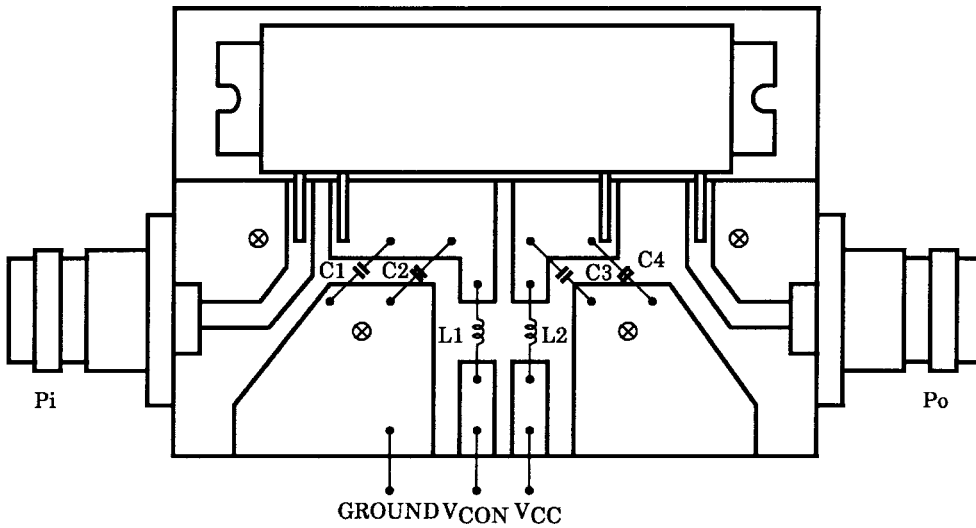

C1, C3: 15000 pF

C2, C4: 10 μ F

L1, L2: ϕ 0.8 enamel wire, 8 T, 5ID

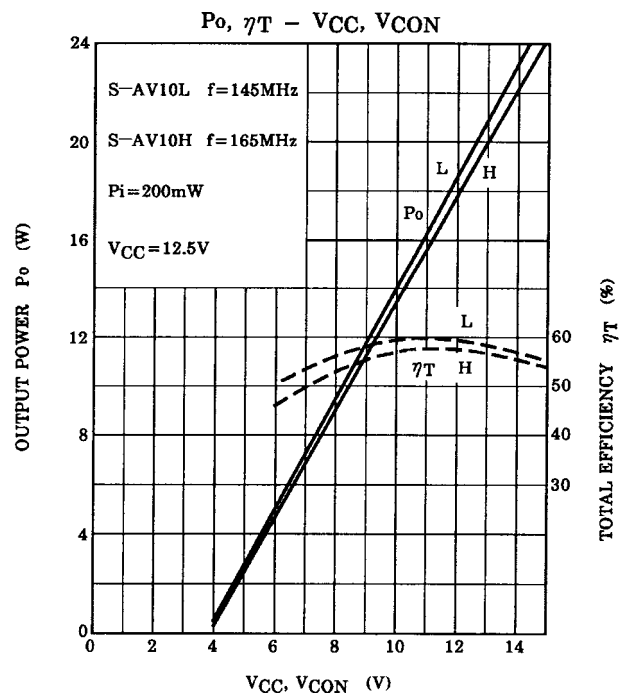
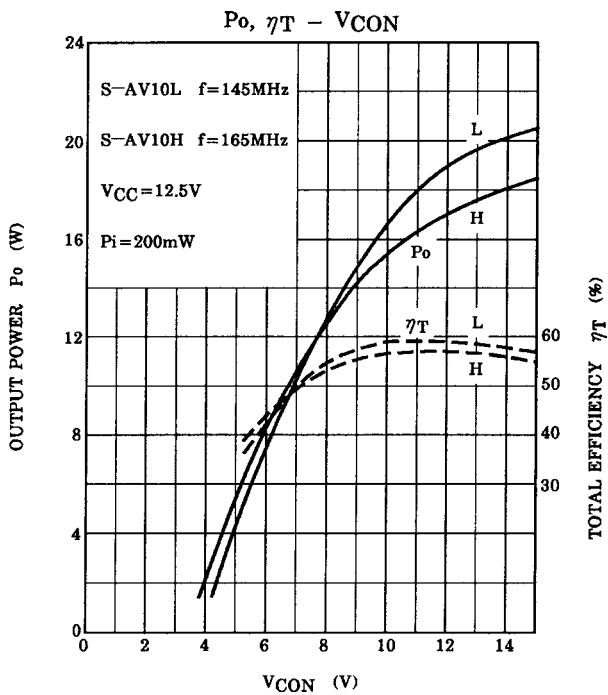
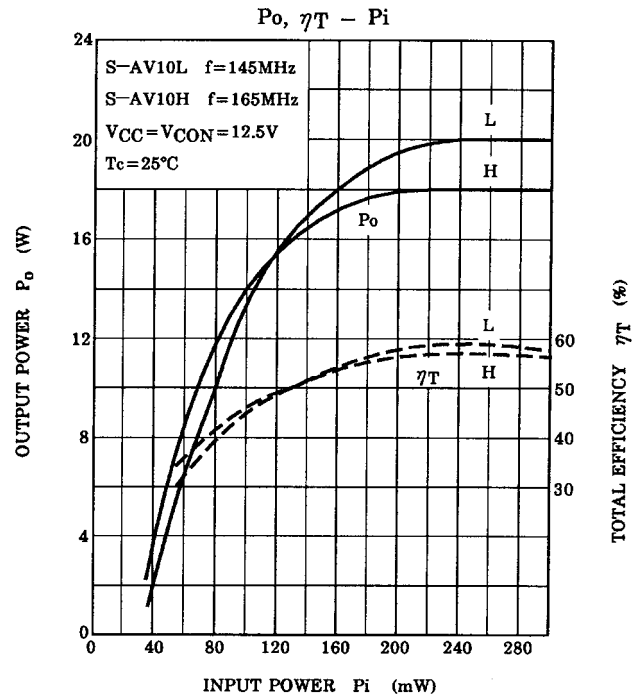
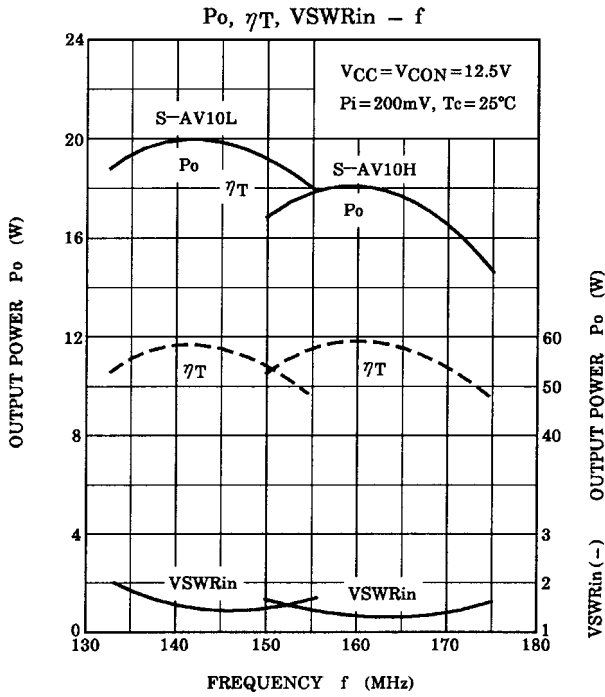

Caution

These are only typical curves and devices are not necessarily guaranteed at these curves.

RESTRICTIONS ON PRODUCT USE

000707EAA

- TOSHIBA is continually working to improve the quality and reliability of its products. Nevertheless, semiconductor devices in general can malfunction or fail due to their inherent electrical sensitivity and vulnerability to physical stress. It is the responsibility of the buyer, when utilizing TOSHIBA products, to comply with the standards of safety in making a safe design for the entire system, and to avoid situations in which a malfunction or failure of such TOSHIBA products could cause loss of human life, bodily injury or damage to property.
In developing your designs, please ensure that TOSHIBA products are used within specified operating ranges as set forth in the most recent TOSHIBA products specifications. Also, please keep in mind the precautions and conditions set forth in the "Handling Guide for Semiconductor Devices," or "TOSHIBA Semiconductor Reliability Handbook" etc..
- The TOSHIBA products listed in this document are intended for usage in general electronics applications (computer, personal equipment, office equipment, measuring equipment, industrial robotics, domestic appliances, etc.). These TOSHIBA products are neither intended nor warranted for usage in equipment that requires extraordinarily high quality and/or reliability or a malfunction or failure of which may cause loss of human life or bodily injury ("Unintended Usage"). Unintended Usage include atomic energy control instruments, airplane or spaceship instruments, transportation instruments, traffic signal instruments, combustion control instruments, medical instruments, all types of safety devices, etc.. Unintended Usage of TOSHIBA products listed in this document shall be made at the customer's own risk.
- The information contained herein is presented only as a guide for the applications of our products. No responsibility is assumed by TOSHIBA CORPORATION for any infringements of intellectual property or other rights of the third parties which may result from its use. No license is granted by implication or otherwise under any intellectual property or other rights of TOSHIBA CORPORATION or others.
- The information contained herein is subject to change without notice.