

# Avago HMMC-5021 (2–22 GHz), HMMC-5026 (2–26.5 GHz)

## Data Sheet

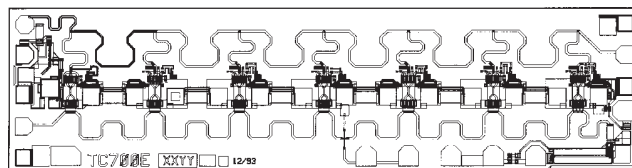

Chip Size:	2980 x 770 $\mu\text{m}$ (117.3 x 30.3 mils)
Chip Size Tolerance:	$\pm 10 \mu\text{m}$ ( $\pm 0.4$ mils)
Chip Thickness:	$127 \pm 15 \mu\text{m}$ ( $5.0 \pm 0.6$ mils)
Pad Dimensions:	$75 \times 75 \mu\text{m}$ ( $2.95 \times 2.95$ mils), or larger

### Description

The HMMC-5021/26 is a broadband GaAs MMIC Traveling Wave Amplifier designed for high gain and moderate output power over the full 2 to 26.5 GHz frequency range. Seven MESFET cascode stages provide a flat gain response, making the HMMC-5021/26 an ideal wideband gain block. Optical lithography is used to produce gate lengths of  $\approx 0.4 \mu\text{m}$ . The HMMC-5021/26 incorporates advanced MBE technology, Ti-Pt-Au gate metallization, silicon nitride passivation, and polyimide for scratch protection.

### Absolute Maximum Ratings<sup>[1]</sup>

Symbol	Parameters/Conditions	Units	Min.	Max.
$V_{DD}$	Positive Drain Voltage	V		8.0
$I_{DD}$	Total Drain Current	mA		250
$V_{G1}$	First Gate Voltage	V	-5	0
$I_{G1}$	First Gate Current	mA	-9	+5
$V_{G2}$ <sup>[2]</sup>	Second Gate Voltage	V	-2.5	+3.5
$I_{G2}$	Second Gate Current	mA	-7	
$P_{DC}$	DC Power Dissipation	watts		2.0
$P_{in}$	CW Input Power	dBm		23
$T_{ch}$	Operating Channel Temp.	$^{\circ}\text{C}$		+150
$T_{case}$	Operating Case Temp.	$^{\circ}\text{C}$	-55	
$T_{stg}$	Storage Temperature	$^{\circ}\text{C}$	-65	+165
$T_{max}$	Max. Assembly Temp. (for 60 seconds max.)	$^{\circ}\text{C}$		300

#### Notes:

- Operation in excess of any one of these conditions may result in permanent damage to this device.  $T_A = 25^{\circ}\text{C}$  except for  $T_{ch}$ ,  $T_{STG}$ , and  $T_{max}$ .
- Minimum voltage on  $V_{G2}$  must not violate the following:  $V_{G2}(\text{min}) > V_{DD} - 9$  volts.

### Features

- **Wide-frequency range:**  
2–26.5 GHz
- **High gain:**  
9.5 dB
- **Gain flatness:**  
 $\pm 0.75$  dB
- **Return loss:**  
Input: -14 dB  
Output: -13 dB
- **Low-frequency operation capability:**  
<2 GHz
- **Gain control:**  
35 dB dynamic range
- **Moderate power:**  
20 GHz:  $P_{-1dB}$ : 18 dBm  
 $P_{sat}$ : 20 dBm  
26.5 GHz:  $P_{-1dB}$ : 15 dBm  
 $P_{sat}$ : 17 dBm

## DC Specifications/Physical Properties<sup>[1]</sup> (Applies to all part numbers)

Symbol	Parameters and Test Conditions	Units	Min.	Typ.	Max.
$I_{DSS}$	Saturated Drain Current ( $V_{DD} = 7.0\text{ V}$ , $V_{G1} = 0\text{ V}$ , $V_{G2} = \text{open circuit}$ )	mA	115	180	250
$V_p$	First Gate Pinch-Off Voltage ( $V_{DD} = 7.0\text{ V}$ , $I_{DD} = 16\text{ mA}$ , $V_{G2} = \text{open circuit}$ )	V	-3.5	-1.5	-0.5
$V_{G2}$	Second Gate Self-Bias Voltage ( $V_{DD} = 7.0\text{ V}$ , $V_{G1} = 0\text{ V}$ )	V		2.1	
$I_{DSOFF}$	First Gate Pinch-Off Current ( $V_{DD} = 7.0\text{ V}$ , $V_{G1} = -3.5\text{ V}$ , $V_{G2} = \text{open circuit}$ )	mA		4	
$I_{DSOFF}$	Second Gate Pinch-Off Current ( $V_{DD} = 5.0\text{ V}$ , $V_{G1} = 0\text{ V}$ , $V_{G2} = -3.5\text{ V}$ )	mA		8	
$\theta_{ch-bs}$	Thermal Resistance ( $T_{backside} = 25^\circ\text{C}$ )	$^\circ\text{C}/\text{W}$		36	

### Notes:

1. Measured in wafer form with  $T_{chuck} = 25^\circ\text{C}$ . (Except  $\theta_{ch-bs}$ .)

## HMMC-5021, -5026 RF Specifications, $V_{DD} = 7.0\text{ V}$ , $I_{DD}(0) = 150\text{ mA}$ , $Z_{in} = Z_o = 50\ \Omega$ <sup>[1]</sup>

Symbol	Parameters/Conditions	Units	2.0–22.0 GHz	2.0–26.5 GHz		Max.
			HMMC-5021	HMMC-5026	Typ.	
			Typ.	Min.	Typ.	
BW	Guaranteed Bandwidth	GHz	2-22	2		26.5
$S_{21}$	Small Signal Gain	dB	10	7.5	9.5	12
$DS_{21}$	Small Signal Gain Flatness	dB	$\pm 0.5$		$\pm 0.75$	$\pm 1.0$
$RL_{in(min)}$	Minimum Input Return Loss	dB	16	10	14	
$RL_{out(min)}$	Minimum Output Return Loss	dB	13	10	13	
Isolation	Minimum Reverse Isolation	dB	32	20	30	
$P_{-1dB}$	Output Power at 1 dB Gain Compression	dBm	18	12	15	
$P_{sat}$	Saturated Output Power	dBm	20	14	17	
$H_{2(max)}$	Max. Second Harm. ( $2 < f_o < 20$ ), [ $P_o(f_o) = 17\text{ dBm}$ or $P_{-1dB}$ , whichever is less.]	dBc	-25		-25	-20
$H_{3(max)}$	Max. Third Harm. ( $2 < f_o < 20$ ), [ $P_o(f_o) = 17\text{ dBm}$ or $P_{-1dB}$ , whichever is less.]	dBc	-34		-34	-20
NF	Noise Figure	dB	8		10	

### Notes:

- Small-signal data measured in wafer form with  $T_{chuck} = 25^\circ\text{C}$ . Large-signal data measured on individual devices mounted in an HP83040 Series Modular Microcircuit Package @  $T_A = 25^\circ\text{C}$ .
- Performance may be extended to lower frequencies through the use of appropriate off-chip circuitry. Upper -3 dB corner frequency  $\approx 29.5\text{ GHz}$ .

## Applications

The HMMC-5021/26 series of traveling wave amplifiers are designed for use as general purpose wideband gain blocks in communication systems and microwave instrumentation. They are ideally suited for broadband applications requiring a flat gain response and excellent port matches over a 2 to 26.5 GHz frequency range. Dynamic gain control and low-frequency extension capabilities are designed into these devices.

## Biasing and Operation

These amplifiers are biased with a single positive drain supply ( $V_{DD}$ ) and a single negative gate supply ( $V_{G1}$ ). The recommended bias conditions for the HMMC-5021/26 are  $V_{DD} = 7.0V$ ,  $I_{DD} = 150\text{ mA}$  for best overall performance. To achieve this drain current level,  $V_{G1}$  is typically biased between  $-0.2V$  and  $-0.5V$ . No other bias supplies or connections to the device are required for 2 to 26.5 GHz operation. See Figure 3 for assembly information.

The HMMC-5021/26 is a DC coupled amplifier. External coupling capacitors are needed on RF IN and RF OUT ports. The drain bias pad is connected to RF and must be decoupled to the lowest operating frequency.

The auxiliary gate and drain contacts are provided when performance below 1 GHz is required. Connect external capacitors to ground to maintain input and output VSWR at low frequencies (see Additional References). Do not apply bias to these pads.

The second gate ( $V_{G2}$ ) can be used to obtain 35 dB (typical) dynamic gain control. For normal operation, no external bias is required on this contact and its self-bias voltage is  $\approx +2.1V$ . Applying an external bias between its open-circuit voltage and  $-2.5$  volts will adjust the gain while maintaining a good input/output port match.

## Assembly Techniques

GaAs MMICs are ESD sensitive. ESD preventive measures must be employed in all aspects of storage, handling, and assembly. MMIC ESD precautions, handling considerations, die attach and bonding methods are critical factors in successful GaAs MMIC performance and reliability. Avago application note #54, "GaAs MMIC ESD, Die Attach and Bonding Guidelines" provides basic information on these subjects.

## Additional References

AN# 31, "2-26.5 GHz Variable Gain Amplifier Using HMMC-5021/22/26 and HMMC-1002 GaAs MMIC," AN# 34, "HMMC-5021/22/26/27 TWA Environmental Data," AN# 41, "HMMC-5021/22/26 S-Parameters Performance as a Function of Bonding Configuration," AN# 47, "HMMC-5021/22/26 2-26.5 GHz GaAs MMIC Distributed Amplifier Conversion Guide," and AN# 1053, "Designing with HMMC-5021/22/26 and HMMC-5027 GaAs MMIC Amplifiers."

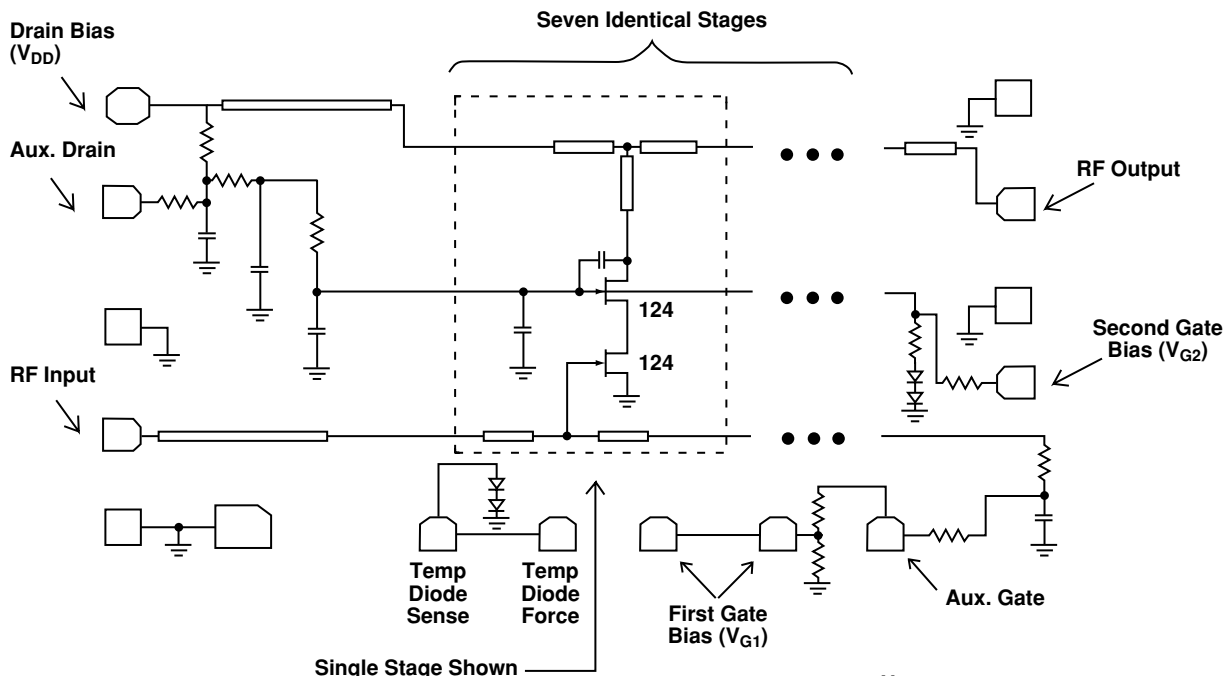

Figure 1. Schematic.

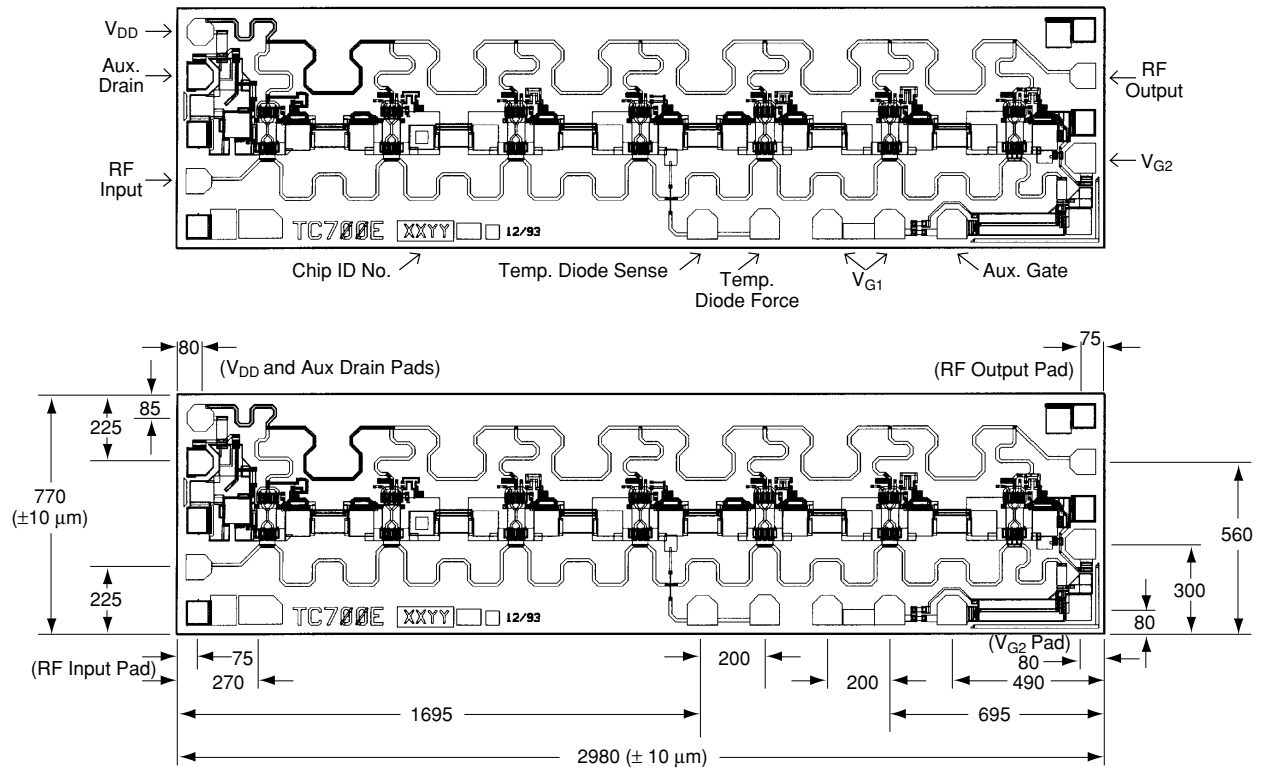
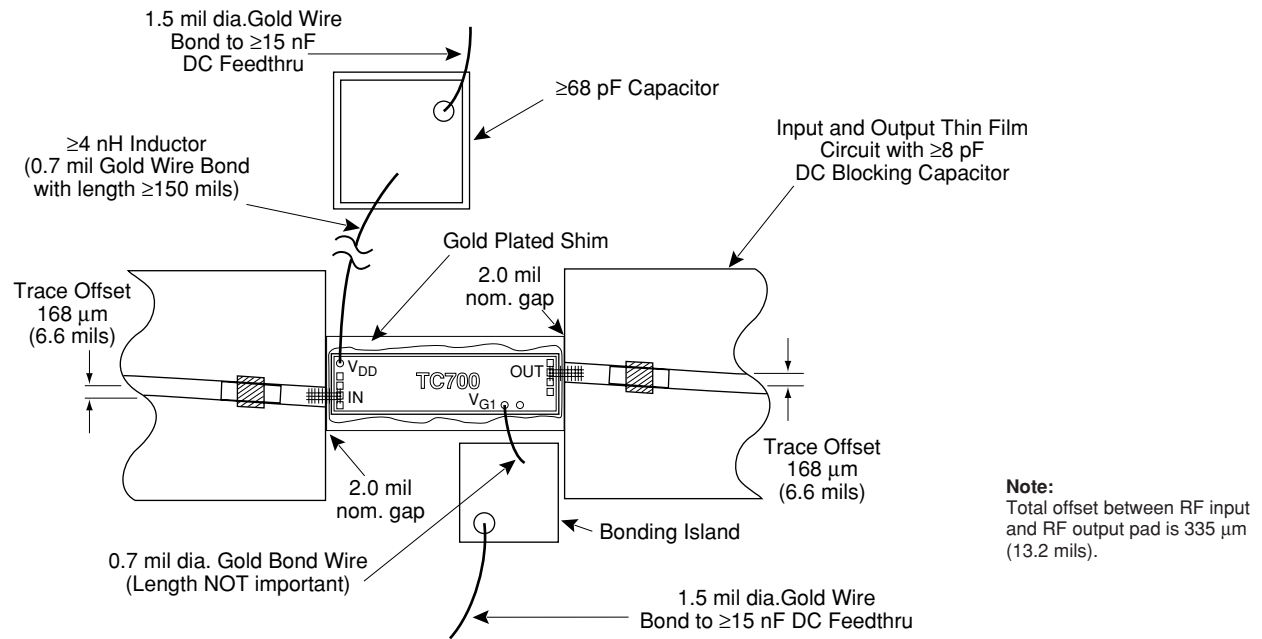

Figure 2. HMMC-5021/26 Bonding Pad Locations.

Notes:  
 All dimensions in microns.  
 Rectangular Pad Dim: 75 x 75 μm.  
 Octagonal Pad Dim: 90 μm dia.  
 All other dimensions ±5 μm  
 (unless otherwise noted).  
 Chip thickness: 127 ± 15 μm.



Note:  
 Total offset between RF input and RF output pad is 335 μm (13.2 mils).

Figure 3. HMMC-5021/26 Assembly Diagram. (For 2.0–26.5 GHz Operation)

### HMMC-5021/26 Typical Performance

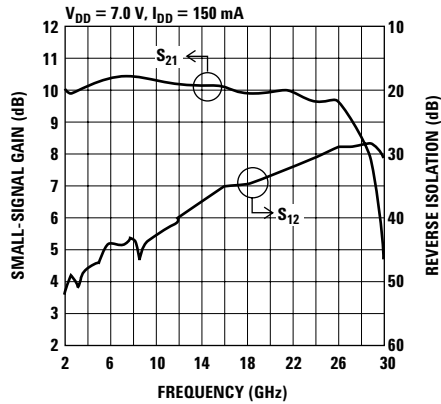

Figure 4. Typical Gain and Reverse Isolation vs. Frequency.

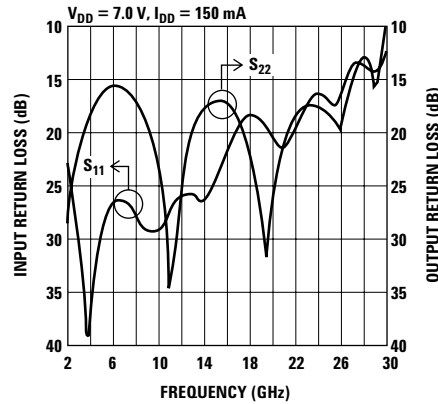

Figure 5. Typical Input and Output Return Loss vs. Frequency.

### Typical Scattering Parameters<sup>[1]</sup>, ( $T_{\text{chuck}} = 25^{\circ}\text{C}$ , $V_{\text{DD}} = 7.0\text{ V}$ , $I_{\text{DD}} = 150\text{ mA}$ , $Z_{\text{in}} = Z_{\text{out}} = 50\Omega$ )

Freq. GHz	$S_{11}$			$S_{21}$			$S_{12}$			$S_{22}$		
	dB	Mag	Ang	dB	Mag	Ang	dB	Mag	Ang	dB	Mag	Ang
2.0	-22.6	0.074	-174.1	-53.1	0.0022	167.3	10.1	3.183	123.6	-28.9	0.036	77.3
3.0	-30.6	0.030	130.4	-51.0	0.0028	120.1	10.0	3.173	102.1	-21.6	0.083	64.1
4.0	-37.8	0.013	-19.8	-48.0	0.0040	95.0	10.2	3.225	78.2	-18.2	0.124	45.4
5.0	-29.4	0.034	-79.9	-46.8	0.0046	67.1	10.3	3.275	53.5	-16.3	0.153	23.4
6.0	-26.6	0.047	-113.8	-44.4	0.0060	36.0	10.4	3.303	28.1	-15.4	0.170	2.5
7.0	-26.6	0.047	-137.0	-44.1	0.0062	1.0	10.4	3.330	2.3	-15.7	0.165	-19.5
8.0	-27.7	0.041	-152.6	-43.4	0.0067	-27.5	10.5	3.331	-23.8	-17.0	0.141	-40.7
9.0	-29.0	0.035	-149.8	-44.3	0.0061	-31.8	10.4	3.312	-50.2	-19.2	0.110	-59.7
10.0	-29.0	0.036	-140.8	-43.0	0.0071	-53.6	10.3	3.282	-76.4	-24.3	0.061	-76.8
11.0	-27.3	0.043	-138.1	-41.6	0.0083	-74.8	10.2	3.253	-102.5	-35.1	0.018	-32.6
12.0	-26.2	0.049	-141.9	-40.0	0.0100	-96.9	10.2	3.227	-128.8	-24.6	0.059	21.0
13.0	-25.8	0.052	-148.5	-38.9	0.0113	-120.9	10.2	3.218	-155.4	-19.7	0.103	2.8
14.0	-26.4	0.048	-143.0	-38.1	0.0125	-145.6	10.1	3.204	177.8	-17.6	0.132	-21.2
15.0	-24.6	0.059	-131.7	-36.6	0.0148	-169.9	10.1	3.197	150.4	-17.0	0.141	-44.8
16.0	-21.6	0.083	-133.7	-35.3	0.0172	160.9	10.0	3.177	122.5	-17.1	0.140	-67.4
17.0	-19.4	0.107	-143.5	-35.0	0.0177	130.6	10.0	3.149	94.4	-18.5	0.119	-91.8
18.0	-18.3	0.121	-158.7	-34.7	0.0184	105.0	9.9	3.138	65.9	-21.8	0.081	-116.0
19.0	-18.7	0.116	-172.6	-33.9	0.0201	80.2	9.9	3.140	36.8	-28.9	0.036	-121.7
20.0	-20.3	0.097	-179.5	-33.3	0.0217	50.7	10.0	3.151	6.6	-28.5	0.038	-57.0
21.0	-21.8	0.082	-168.3	-32.7	0.0233	22.5	10.0	3.150	-24.9	-21.7	0.082	-59.1
22.0	-19.9	0.101	-155.3	-31.7	0.0259	-8.4	9.9	3.126	-57.5	-18.6	0.117	-81.5
23.0	-17.3	0.137	-158.8	-31.4	0.0268	-39.5	9.8	3.076	-91.0	-17.3	0.137	-103.3
24.0	-16.3	0.153	-169.9	-30.7	0.0291	-71.5	9.7	3.045	-125.5	-17.3	0.137	-123.8
25.0	-17.1	0.139	-175.4	-30.0	0.0317	-106.2	9.7	3.045	-162.2	-18.5	0.118	-135.3
26.0	-17.0	0.141	-165.0	-29.2	0.0345	-145.5	9.6	3.027	157.2	-19.4	0.107	-122.5
26.5	-15.7	0.163	-161.1	-29.0	0.0356	-166.7	9.5	2.970	135.4	-17.6	0.132	-114.2
27.0	-14.3	0.192	-162.7	-28.9	0.0357	171.7	9.2	2.876	112.9	-15.3	0.173	-116.0
28.0	-13.2	0.220	-175.7	-28.8	0.0362	126.3	8.5	2.648	65.8	-12.6	0.233	-138.1
29.0	-14.1	0.197	-176.9	-28.6	0.0371	73.0	7.7	2.433	10.3	-15.4	0.170	-144.7
30.0	-11.5	0.266	-171.6	-30.8	0.0287	4.8	4.6	1.689	-61.1	-8.7	0.369	-123.6

**Note:**

1. Data obtained from on-wafer measurements.

## HMMC-5021/26 Typical Temperature Performance

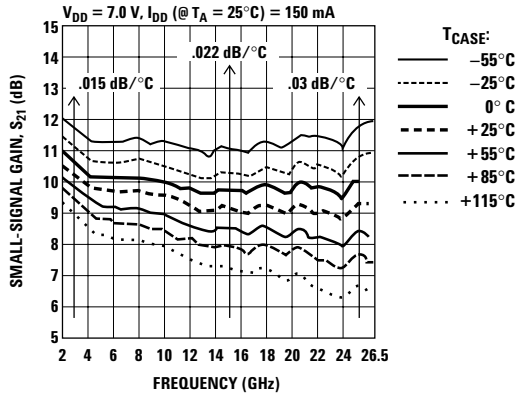

Figure 6. Typical Small-Signal Gain vs. Temperature.

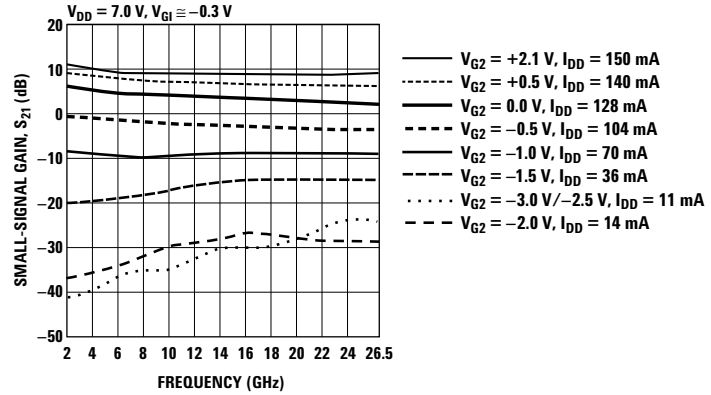

Figure 7. Typical Gain vs. Second Gate Control Voltage.

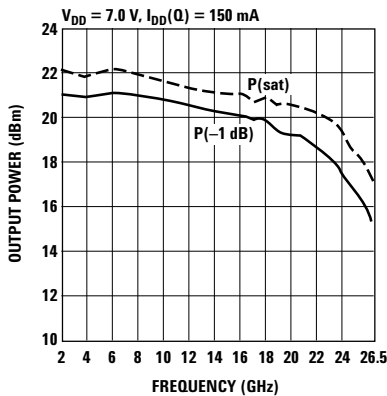

Figure 8. Typical 1 dB Gain Compression and Saturated Output Power.

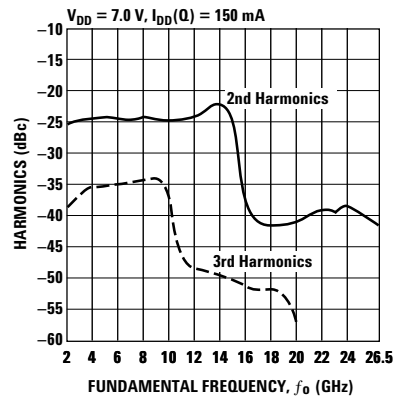

Figure 9. Typical Second and Third Harmonics vs. Fundamental Frequency at  $P_{OUT} = +17$  dBm.

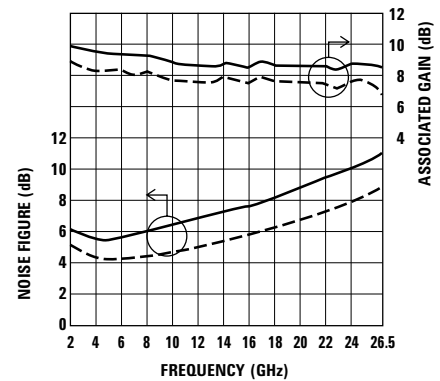

Figure 10. Typical Noise Figure Performance.

— Standard Bias:  
 $V_{DD} = 7.0$  V,  $I_{DD} = 150$  mA  
 - - - Optimal NF Bias:  
 $V_{DD} = 6.0$  V,  $I_{DD} = 66$  mA

**Note:**

- All data measured on individual devices mounted in an HP83040 Series Modular Microcircuit Package @  $T_A = 25^\circ\text{C}$  (except where noted).

This data sheet contains a variety of typical and guaranteed performance data. The information supplied should not be interpreted as a complete list of circuit specifications. In this data sheet the term *typical* refers to the 50th percentile performance. For additional information contact your local Avago Technologies' sales representative.

For product information and a complete list of distributors, please go to our web site:

[www.avagotech.com](http://www.avagotech.com)

Avago, Avago Technologies, and the A logo are trademarks of Avago Technologies, Limited in the United States and other countries.  
 Data subject to change. Copyright © 2006 Avago Technologies, Limited. All rights reserved.  
 Obsoletes 5965-5449E  
 5988-1893EN March 12, 2007

**AVAGO**  
 TECHNOLOGIES