

HMMC-5023

23 GHz LNA (21.2–26.5 GHz)

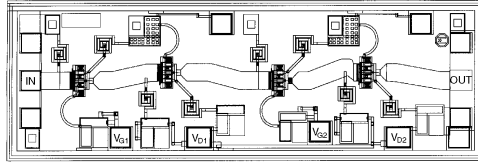

Data Sheet



Chip Size: 1880 x 600 μm (74 x 23.6 mils)
 Chip Size Tolerance: $\pm 10 \mu\text{m}$ (± 0.4 mils)
 Chip Thickness: $127 \pm 15 \mu\text{m}$ (5.0 ± 0.6 mils)
 Pad Dimensions: $80 \times 80 \mu\text{m}$ (3.1 x 3.1 mils), or larger

Description

The HMMC-5023 MMIC is a high-gain low-noise amplifier (LNA) that operates from 21 GHz to over 30 GHz. By eliminating the complex tuning and assembly processes typically required by hybrid (discrete-FET) amplifiers, the HMMC-5023 is a cost-effective alternative in both 21.2–23.6 GHz and 24.5–26.5 GHz communications receivers. The device has good input and output match to 50 ohms and is unconditionally stable to more than 40 GHz. The backside of the chip is both RF and DC ground. This helps simplify the assembly process and reduces assembly related performance variations and costs. It is fabricated using a PHEMT integrated circuit structure that provides exceptional noise and gain performance.

Features

- Frequency range:
 - 21.2–23.6 GHz and
 - 24.5–26.5 GHz specified.
 - 21–30 GHz performance
- Low noise temperature: 226 K (2.5 dB N.F.) typical
- High gain: 24 dB typical
- 50 Ω input/output matching
- Single supply bias with optional bias adjust: 5 volts (@ 24 mA typical)

Absolute Maximum Ratings^[1]

Symbol	Parameters/Conditions	Units	Min.	Max.
V_{D1}, V_{D2}	Drain Supply Voltage	V	3	8
V_{G1}, V_{G2}	Gate Supply Voltage	V	0.4	2
I_{D1}	Drain Supply Current	mA		35
I_{D2}	Drain Supply Current	mA		35
P_{in}	RF Input Power ^[2]	dBm		15
T_{ch}	Channel Temperature ^[3]	$^{\circ}\text{C}$		150
T_A	Backside Ambient Temp	$^{\circ}\text{C}$	-55	+140
T_{st}	Storage Temp	$^{\circ}\text{C}$	-65	+165
T_{max}	Max. Assembly Temp	$^{\circ}\text{C}$		300

Notes:

1. Absolute maximum ratings for continuous operation unless otherwise noted.
2. Operating at this power level for extended (continuous) periods is not recommended.
3. Refer to DC Specifications/Physical Properties table for de-rating information.

DC Specifications/Physical Properties^[1]

Symbol	Parameters and Test Conditions	Units	Min.	Typ.	Max.
V_{D1}, V_{D2}	Recommended Drain Supply Voltage	V	3	5	7
V_{G1}, V_{G2}	Gate Supply Voltage ($V_{D1} \leq V_{D1(max)}$, $V_{D2} \leq V_{D2(max)}$)	V	0.4	0.8 ^[2]	2
I_{D1}, I_{D2}	Input and Output Stage Drain Supply Current ($V_{G1} = V_{G2} = \text{Open}$, $V_{D1} = V_{D2} = 5 \text{ Volts}$)	mA		12	35
$I_{D1} + I_{D2}$	Total Drain Supply Current ($V_{G1} = V_{G2} = \text{Open}$, $V_{D1} = V_{D2} = 5 \text{ Volts}$)	mA	13	24	30
θ_{ch-bs}	Thermal Resistance ^[3] (Channel-to-Backside at $T_{ch} = 150^\circ\text{C}$)	$^\circ\text{C}/\text{W}$		75	
T_{ch}	Channel Temperature ^[4] ($T_A = 140^\circ\text{C}$, $\text{MTTF} = 10^6 \text{ hrs}$, $V_{G1} = V_{G2} = \text{Open}$, $V_{D1} = V_{D2} = 5 \text{ Volts}$)	$^\circ\text{C}$		150	

Notes:

- Backside ambient operating temperature $T_A = 25^\circ\text{C}$ unless otherwise noted.
- Open circuit voltage at V_{G1} and V_{G2} when V_{D1} and V_{D2} are 5 Volts.
- Thermal resistance (in $^\circ\text{C}/\text{Watt}$) at a channel temperature $T(^\circ\text{C})$ can be estimated using the equation:

$$\theta(T) \cong 75 \times [T(^\circ\text{C}) + 273] / [150^\circ\text{C} + 273]$$
- Derate MTTF by a factor of two for every 8°C above T_{ch} .

HMMC-5023 RF Specifications, ($T_{op} = 25^\circ\text{C}$, $V_{D1} = V_{D2} = 5\text{V}$, $V_{G1} = V_{G2} = \text{Open}$, $Z_0 = 50\Omega$, unless otherwise noted)

Symbol	Parameters/Conditions	Units	21.2–23.6 GHz			24.5–26.5 GHz		
			Min.	Typ.	Max.	Min.	Typ.	Max.
BW	Operating Bandwidth	GHz	21.2		23.6	24.5		26.5
Gain	Small Signal Gain	dB	21	24	28	17	21	25
Δ Gain	Small Signal Gain Flatness	dB		± 1			± 1.5	
$RL_{in(min)}$	Minimum Input Return Loss	dB	10	12		12	20	
$RL_{out(min)}$	Minimum Output Return Loss	dB	8	10		8	10	
Isolation	Reverse Isolation	dB	40	50		40	48	
P_{-1dB}	Output Power @ 1 dB Gain Compression	dBm		10			10	
	Output Power @ 1 dB Gain Compression ($V_D = 5\text{V}$, $V_{G1} = \text{Open}$, $V_{D2} = 7\text{V}$, V_{G2} set for $I_{D2} = 35\text{mA}$)	dBm		14			14	
P_{sat}	Saturated Output Power (@ 3 dB Gain Compression)	dBm		12			12	
2nd Harm.	Second Harmonic Power Level [$f = 2f_o$, $P_{out}(f_o) = P_{-1dB}$, 21.2 GHz $\leq f_o \leq$ 23.6 GHz]	dBc		-30			-30	
NF	Noise Figure: 22 GHz	dB		2.5	3.0			
	Noise Figure: 25 GHz						2.8	3.3

Applications

The HMMC-5023 low noise amplifier (LNA) is designed for use in digital radio communication systems that operate within the 21.2 GHz to 23.6 GHz and 24.5 to 26.5 GHz frequency bands. High gain and low noise temperature make it ideally suited as a front-end gain stage. The MMIC solution is a cost effective alternative to hybrid assemblies.

Biasing and Operation

The HMMC-5023 has four cascaded gain stages as shown in Figure 1. The first two gain stages at the input are biased with the V_{D1} drain supply. Similarly the two output stages are biased with the V_{D2} supply. Standard LNA operation is with a single positive DC drain supply voltage ($V_{D1} = V_{D2} = 5\text{ V}$) using the assembly diagram shown in Figure 8(a). If desired, the output stage DC supply voltage (V_{D2}) can be increased to improve output

power capability while maintaining optimum low noise bias conditions for the input section. The output power may also be adjusted by applying a positive voltage at V_{G2} to alter the operating bias point for both output FETs. Increasing the voltage applied to V_{G2} (more positively) results in a more negative gate-to-source voltage and, therefore, lower drain current. Figures 8(b) and 8(c) illustrate how the device can be assembled for both independent drain supply operation and for output-stage gate bias control. No ground wires are required since ground connections are made with plated through-holes to the backside of the device.

Assembly Techniques

It is recommended that the RF input and RF output connections be made using either 500 line/inch (or equivalent) gold wire mesh, or dual 0.7 mil diameter gold wire. The RF wires should

be kept as short as possible to minimize inductance. The bias supply wire can be a 0.7 mil diameter gold wire attached to either of the V_{DD} bonding pads. GaAs MMICs are ESD sensitive. ESD preventive measures must be employed in all aspects of storage, handling, and assembly. MMIC ESD precautions, handling considerations, die attach and bonding methods are critical factors in successful GaAs MMIC performance and reliability. Avago application note #54, "GaAs MMIC ESD, Die Attach and Bonding Guidelines" provides basic information on these subjects.

Additional References:

AN# 7, "HMMC-5023 32 GHz Noise Figure Measurements,"
AN# 11, "HMMC-5023 as a Doubler to 24 and 28 GHz," and
AN# 13, "HMMC-5023 Configured as a Gain Control Device at 24 and 28 GHz."

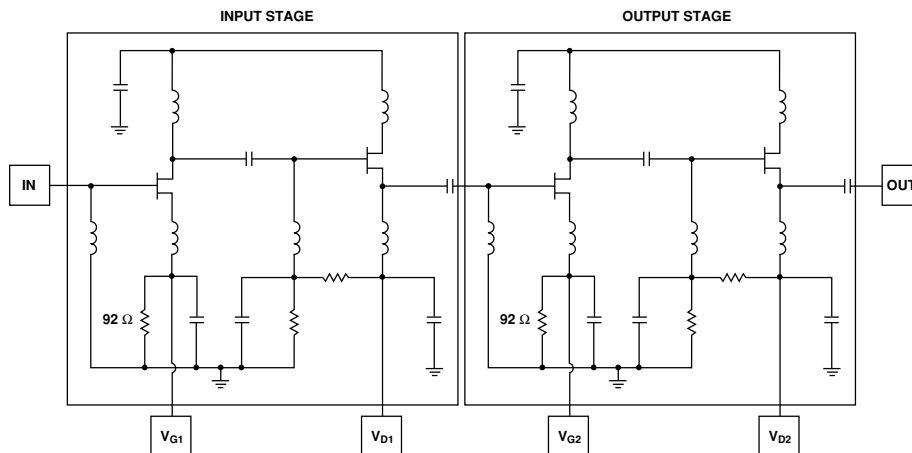

Figure 1. HMMC-5023 Simplified Schematic Diagram.

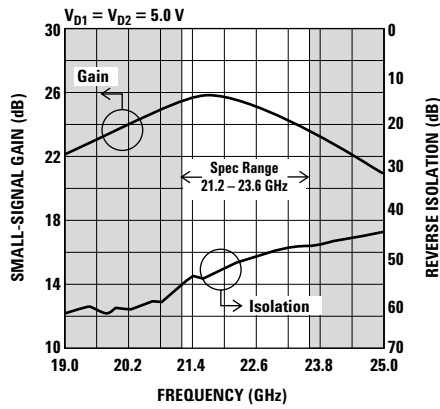

Figure 2. Gain and Isolation vs. Frequency.

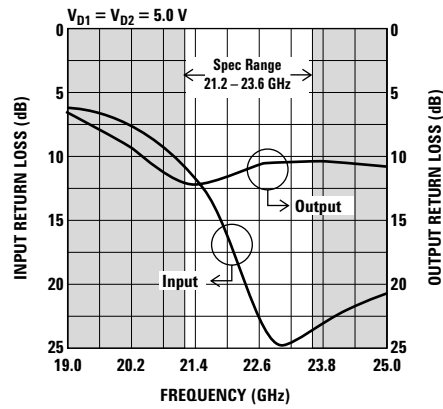

Figure 3. Input and Output Return Loss vs. Frequency.

S-Parameters^[1], ($T_{op} = 25^{\circ}C$, $V_{D1} = V_{D2} = 5V$, $V_{G1} = V_{G2} = Open$, $Z_0 = 50\Omega$)

Freq. GHz	S_{11}			S_{12}			S_{21}			S_{22}		
	dB	Mag	Ang	dB	Mag	Ang	dB	Mag	Ang	dB	Mag	Ang
19.0	-6.3	0.486	61.9	-61.6	0.0008	122.7	22.3	13.090	83.3	-6.6	0.470	-179.1
19.2	-6.4	0.477	59.4	-61.6	0.0008	116.3	22.6	13.509	74.2	-6.9	0.450	175.7
19.4	-6.6	0.466	56.7	-61.0	0.0009	113.1	22.5	13.355	64.0	-7.4	0.427	169.7
19.6	-6.8	0.455	53.8	-61.3	0.0009	104.2	23.2	14.459	56.1	-7.9	0.403	163.5
19.8	-7.1	0.443	50.6	-62.3	0.0008	93.0	23.0	14.142	45.0	-8.4	0.381	156.5
20.0	-7.4	0.428	47.1	-61.2	0.0009	72.6	23.5	14.913	36.4	-8.9	0.358	148.8
20.2	-7.8	0.409	43.8	-61.3	0.0009	66.1	23.9	15.599	26.2	-9.5	0.333	139.9
20.4	-8.2	0.391	40.2	-60.9	0.0009	47.3	24.4	16.617	15.7	-10.2	0.309	130.7
20.6	-8.7	0.368	36.2	-59.5	0.0011	25.8	24.7	17.085	5.7	-10.8	0.290	119.5
20.8	-9.3	0.344	31.8	-59.6	0.0011	11.5	25.1	18.061	-4.7	-11.2	0.274	106.2
21.0	-10.0	0.318	27.4	-58.2	0.0012	-4.2	25.4	18.663	-15.3	-11.7	0.259	91.3
21.2	-10.8	0.288	22.9	-56.0	0.0016	-17.6	25.6	19.010	-26.6	-12.0	0.252	74.6
21.4	-11.8	0.256	18.4	-54.9	0.0018	-36.9	25.7	19.209	-38.7	-12.1	0.247	56.4
21.6	-13.1	0.220	14.9	-55.1	0.0018	-52.2	25.7	19.209	-51.3	-12.2	0.247	38.2
21.8	-14.7	0.185	12.1	-53.8	0.0020	-64.6	25.7	19.354	-61.4	-11.9	0.254	21.9
22.0	-16.5	0.149	11.0	-52.5	0.0024	-75.8	25.9	19.769	-74.0	-11.7	0.261	6.8
22.2	-18.5	0.118	12.1	-51.2	0.0028	-90.4	25.6	19.066	-85.2	-11.3	0.271	-6.6
22.4	-20.6	0.094	15.9	-50.5	0.0030	-100.3	25.6	19.113	-96.2	-11.0	0.282	-18.4
22.6	-22.7	0.074	22.8	-50.0	0.0031	-108.7	25.0	17.824	-107.5	-10.7	0.291	-28.7
22.8	-24.3	0.061	37.4	-49.3	0.0034	-118.9	25.1	17.943	-116.9	-10.5	0.298	-37.9
23.0	-24.9	0.057	54.0	-48.5	0.0037	-126.2	24.3	16.401	-127.6	-10.4	0.301	-45.5
23.2	-24.7	0.059	68.3	-47.6	0.0042	-134.9	24.2	16.279	-137.5	-10.4	0.300	-52.3
23.4	-24.2	0.061	78.9	-47.3	0.0043	-144.0	23.9	15.625	-146.3	-10.5	0.298	-58.0
23.6	-23.6	0.066	86.3	-47.2	0.0044	-148.9	23.2	14.469	-154.0	-10.6	0.295	-62.4
23.8	-23.3	0.068	93.5	-46.9	0.0045	-156.1	23.3	14.607	-163.4	-10.5	0.298	-65.9
24.0	-22.6	0.074	98.0	-46.4	0.0048	-161.1	22.4	13.168	-170.8	-10.6	0.296	-69.2
24.2	-22.2	0.078	100.8	-46.1	0.0049	-167.3	22.3	13.002	-179.0	-10.6	0.294	-72.0
24.4	-21.8	0.082	102.8	-45.5	0.0053	-171.7	21.6	12.087	173.1	-10.6	0.294	-74.7
24.6	-21.4	0.086	105.5	-45.6	0.0052	-176.4	21.8	12.350	166.3	-10.7	0.291	-76.8
24.8	-21.2	0.088	108.1	-44.9	0.0057	179.1	21.4	11.771	159.2	-10.8	0.289	-78.4
25.0	-20.9	0.091	293.2	-44.4	0.0061	353.0	21.0	11.257	331.9	-10.8	0.289	-79.3

Note:

1. Data obtained from wafer-probed measurements.

HMMC-5023 Typical Performance

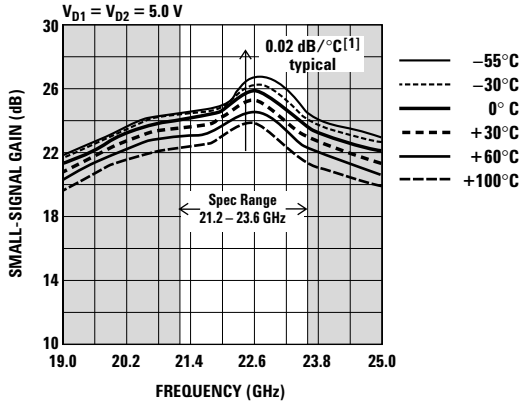

Figure 4. Small-Signal Gain vs. Frequency and Ambient Temperature^[1].

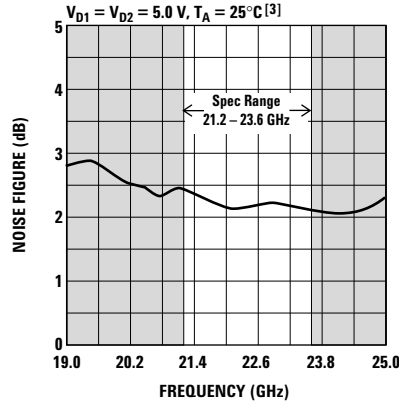

Figure 5. Noise Figure vs. Frequency^[2].

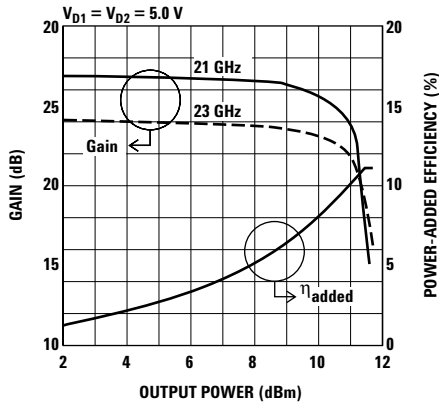

Figure 6. Gain Compression and Efficiency Characteristics^[2].

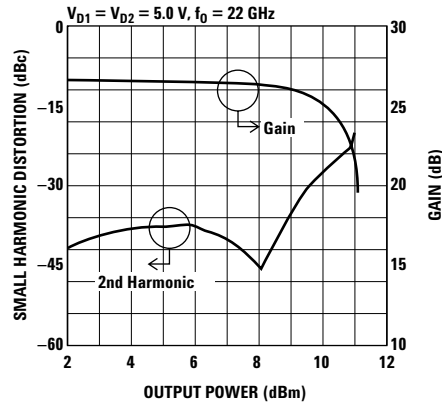

Figure 7. Second Harmonic and Gain Compression Characteristics^[2].

Notes:

1. Device tested while mounted on a HP83040 Modular Microcircuit Fixture calibrated at the coaxial connectors. Test results shown have been degraded by the fixture due to loss and impedance mismatch errors. The temperature coefficient of the fixture alone is approximately 0.003 dB/°C at 20 GHz.
2. Data obtained from wafer-probed measurements.
3. The temperature coefficient of noise figure was measured for one device mounted on a HP83040 Modular Microcircuit Fixture. The uncorrected result, <0.014 dB/°C, includes the effects of the fixture.

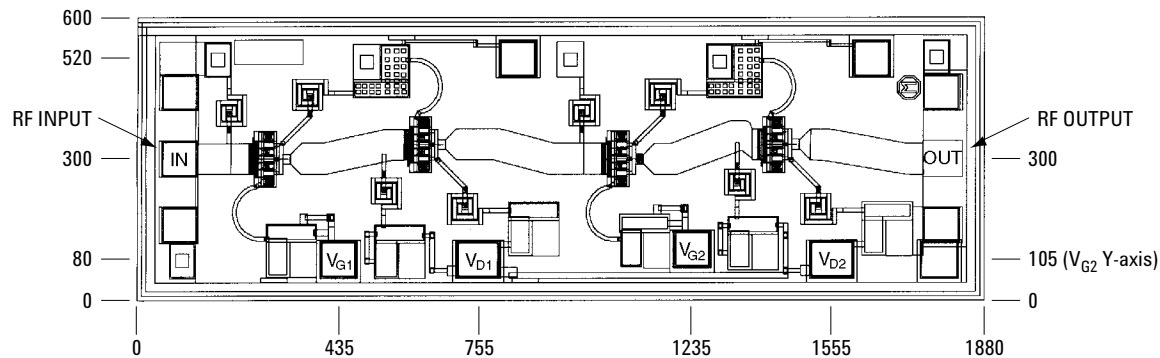

Figure 8. HMMC-5023 Bonding Pad Locations. (Dimensions are in micrometers)

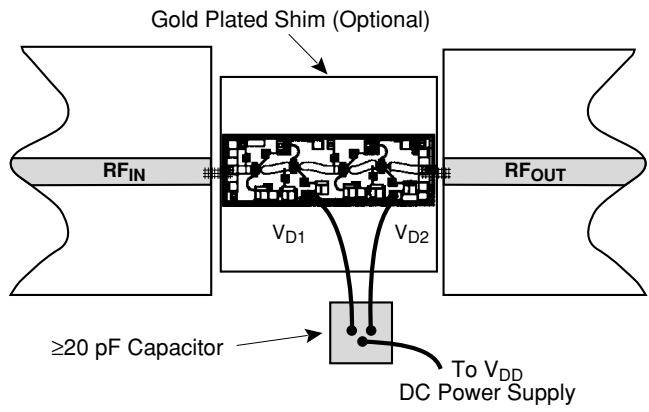

Figure 9a. Single DC Drain Supply.

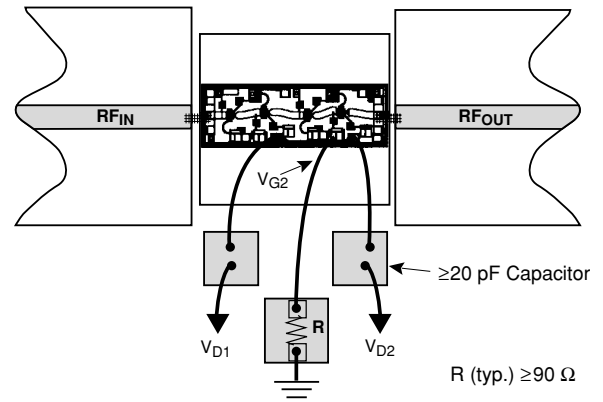

Figure 9b. Assembly for custom biasing of output gain stages using an external chip resistor.

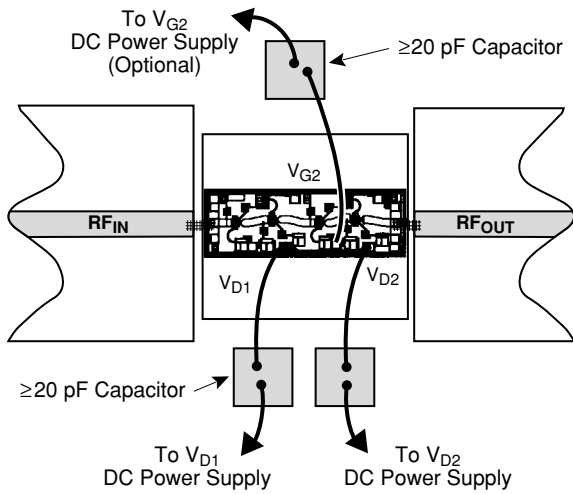

Figure 9c. A V_{G2} DC supply or a resistive divider network can also be used to bias the output stages for custom applications.

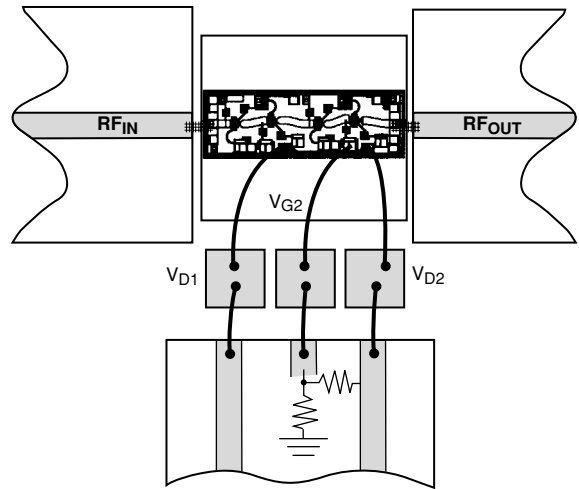

Figure 9. HMMC-5023 Assembly Diagram Examples.

This data sheet contains a variety of typical and guaranteed performance data. The information supplied should not be interpreted as a complete list of circuit specifications. In this data sheet the term *typical* refers to the 50th percentile performance. For additional information contact your local Avago Technologies' sales representative.

For product information and a complete list of distributors, please go to our web site:
www.avagotech.com

Avago, Avago Technologies, and the A logo are trademarks of Avago Technologies, Limited in the United States and other countries.
Data subject to change. Copyright © 2006 Avago Technologies, Limited. All rights reserved.
Obsoletes 5965-5448E
5988-2712EN November 14, 2006

