



RF Power Field Effect Transistor

N-Channel Enhancement-Mode Lateral MOSFET

Designed for broadband commercial and industrial applications with frequencies from 865 to 895 MHz. The high gain and broadband performance of this device make it ideal for large- signal, common- source amplifier applications in 26 volt base station equipment.

- Typical CDMA Performance @ 880 MHz, 26 Volts, $I_{DQ} = 1400$ mA
IS-95 CDMA Pilot, Sync, Paging, Traffic Codes 8 Through 13
Output Power — 40 Watts
Power Gain — 17 dB
Efficiency — 26%
Adjacent Channel Power -
750 kHz: -45.0 dBc in 30 kHz BW
1.98 MHz: -60.0 dBc in 30 kHz BW
- Capable of Handling 10:1 VSWR, @ 26 Vdc, 880 MHz, 170 Watts CW Output Power

Features

- Internally Matched for Ease of Use
- High Gain, High Efficiency and High Linearity
- Integrated ESD Protection
- Designed for Maximum Gain and Insertion Phase Flatness
- Excellent Thermal Stability
- Characterized with Series Equivalent Large-Signal Impedance Parameters
- RoHS Compliant
- In Tape and Reel. R6 Suffix = 150 Units per 56 mm, 13 inch Reel.

MRF9180R6

**880 MHz, 170 W, 26 V
LATERAL N-CHANNEL
RF POWER MOSFET**

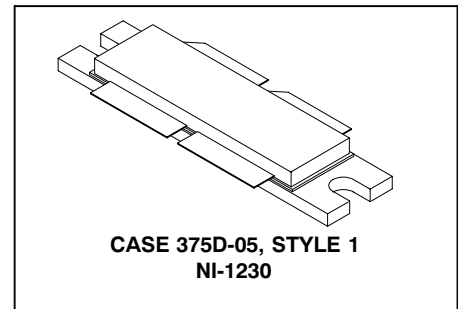

ARCHIVE INFORMATION

ARCHIVE INFORMATION

Table 1. Maximum Ratings

Rating	Symbol	Value	Unit
Drain-Source Voltage	V_{DSS}	-0.5, +65	Vdc
Gate-Source Voltage	V_{GS}	-0.5, +15	Vdc
Total Device Dissipation @ $T_C = 25^\circ\text{C}$ Derate above 25°C	P_D	388 2.22	W W/ $^\circ\text{C}$
Storage Temperature Range	T_{stg}	-65 to +150	$^\circ\text{C}$
Case Operating Temperature	T_C	150	$^\circ\text{C}$
Operating Junction Temperature	T_J	200	$^\circ\text{C}$

Table 2. Thermal Characteristics

Characteristic	Symbol	Value	Unit
Thermal Resistance, Junction to Case	$R_{\theta JC}$	0.45	$^\circ\text{C}/\text{W}$

Table 3. ESD Protection Characteristics

Test Conditions	Class
Human Body Model	1 (Minimum)
Machine Model	M1 (Minimum)

Table 4. Electrical Characteristics ($T_C = 25^\circ\text{C}$ unless otherwise noted)

Characteristic	Symbol	Min	Typ	Max	Unit
Off Characteristics ⁽¹⁾					
Zero Gate Voltage Drain Leakage Current ($V_{DS} = 65\text{ Vdc}$, $V_{GS} = 0\text{ Vdc}$)	I_{DSS}	—	—	10	μAdc
Zero Gate Voltage Drain Leakage Current ($V_{DS} = 26\text{ Vdc}$, $V_{GS} = 0\text{ Vdc}$)	I_{DSS}	—	—	1	μAdc
Gate-Source Leakage Current ($V_{GS} = 5\text{ Vdc}$, $V_{DS} = 0\text{ Vdc}$)	I_{GSS}	—	—	1	μAdc
On Characteristics					
Gate Threshold Voltage ⁽¹⁾ ($V_{DS} = 10\text{ Vdc}$, $I_D = 300\ \mu\text{Adc}$)	$V_{GS(th)}$	2	2.9	4	Vdc
Gate Quiescent Voltage ⁽²⁾ ($V_{DS} = 26\text{ Vdc}$, $I_D = 1400\text{ mAdc}$)	$V_{GS(Q)}$	—	3.7	—	Vdc
Drain-Source On-Voltage ⁽¹⁾ ($V_{GS} = 10\text{ Vdc}$, $I_D = 2\text{ Adc}$)	$V_{DS(on)}$	—	0.19	0.5	Vdc
Forward Transconductance ⁽¹⁾ ($V_{DS} = 10\text{ Vdc}$, $I_D = 6\text{ Adc}$)	g_{fs}	—	6	—	S
Dynamic Characteristics ^(1,3)					
Output Capacitance ($V_{DS} = 26\text{ Vdc} \pm 30\text{ mV(rms)ac}$ @ 1 MHz, $V_{GS} = 0\text{ Vdc}$)	C_{oss}	—	77	—	pF
Reverse Transfer Capacitance ($V_{DS} = 26\text{ Vdc} \pm 30\text{ mV(rms)ac}$ @ 1 MHz, $V_{GS} = 0\text{ Vdc}$)	C_{rss}	—	3.8	—	pF
Functional Tests ⁽²⁾ (In Freescale Test Fixture, 50 ohm system)					
Two-Tone Common-Source Amplifier Power Gain ($V_{DD} = 26\text{ Vdc}$, $P_{out} = 170\text{ W PEP}$, $I_{DQ} = 1400\text{ mA}$, $f_1 = 880.0\text{ MHz}$, $f_2 = 880.1\text{ MHz}$)	G_{ps}	16	17.5	—	dB
Two-Tone Drain Efficiency ($V_{DD} = 26\text{ Vdc}$, $P_{out} = 170\text{ W PEP}$, $I_{DQ} = 1400\text{ mA}$, $f_1 = 880.0\text{ MHz}$, $f_2 = 880.1\text{ MHz}$)	η	35	39	—	%
3rd Order Intermodulation Distortion ($V_{DD} = 26\text{ Vdc}$, $P_{out} = 170\text{ W PEP}$, $I_{DQ} = 1400\text{ mA}$, $f_1 = 880.0\text{ MHz}$, $f_2 = 880.1\text{ MHz}$)	IMD	—	-31	-28	dBc
Input Return Loss ($V_{DD} = 26\text{ Vdc}$, $P_{out} = 170\text{ W PEP}$, $I_{DQ} = 1400\text{ mA}$, $f_1 = 880.0\text{ MHz}$, $f_2 = 880.1\text{ MHz}$)	IRL	—	-15	-9	dB
Two-Tone Common-Source Amplifier Power Gain ($V_{DD} = 26\text{ Vdc}$, $P_{out} = 170\text{ W PEP}$, $I_{DQ} = 1400\text{ mA}$, $f_1 = 865.0\text{ MHz}$, $f_2 = 865.1\text{ MHz}$)	G_{ps}	—	17.5	—	dB
Two-Tone Drain Efficiency ($V_{DD} = 26\text{ Vdc}$, $P_{out} = 170\text{ W PEP}$, $I_{DQ} = 1400\text{ mA}$, $f_1 = 865.0\text{ MHz}$, $f_2 = 865.1\text{ MHz}$)	η	—	38.5	—	%
3rd Order Intermodulation Distortion ($V_{DD} = 26\text{ Vdc}$, $P_{out} = 170\text{ W PEP}$, $I_{DQ} = 1400\text{ mA}$, $f_1 = 865.0\text{ MHz}$, $f_2 = 865.1\text{ MHz}$)	IMD	—	-31	—	dBc
Input Return Loss ($V_{DD} = 26\text{ Vdc}$, $P_{out} = 170\text{ W PEP}$, $I_{DQ} = 1400\text{ mA}$, $f_1 = 865.0\text{ MHz}$, $f_2 = 865.1\text{ MHz}$)	IRL	—	-13	—	dB

1. Each side of device measured separately.
2. Measurement made with device in push-pull configuration.
3. Part internally input matched.

Table 4. Electrical Characteristics ($T_C = 25^\circ\text{C}$ unless otherwise noted) **(continued)**

Characteristic	Symbol	Min	Typ	Max	Unit
Functional Tests ⁽¹⁾ (In Freescale Test Fixture, 50 ohm system) (continued)					
Power Output, 1 dB Compression Point ($V_{DD} = 26\text{ Vdc}$, CW, $I_{DQ} = 1400\text{ mA}$, $f_1 = 880.0\text{ MHz}$)	P_{1dB}	—	170	—	W
Common-Source Amplifier Power Gain ($V_{DD} = 26\text{ Vdc}$, $P_{out} = 170\text{ W CW}$, $I_{DQ} = 1400\text{ mA}$, $f_1 = 880.0\text{ MHz}$)	G_{ps}	—	16.5	—	dB
Drain Efficiency ($V_{DD} = 26\text{ Vdc}$, $P_{out} = 170\text{ W CW}$, $I_{DQ} = 1400\text{ mA}$, $f_1 = 880.0\text{ MHz}$)	η	—	55	—	%

1. Measurement made with device in push-pull configuration.

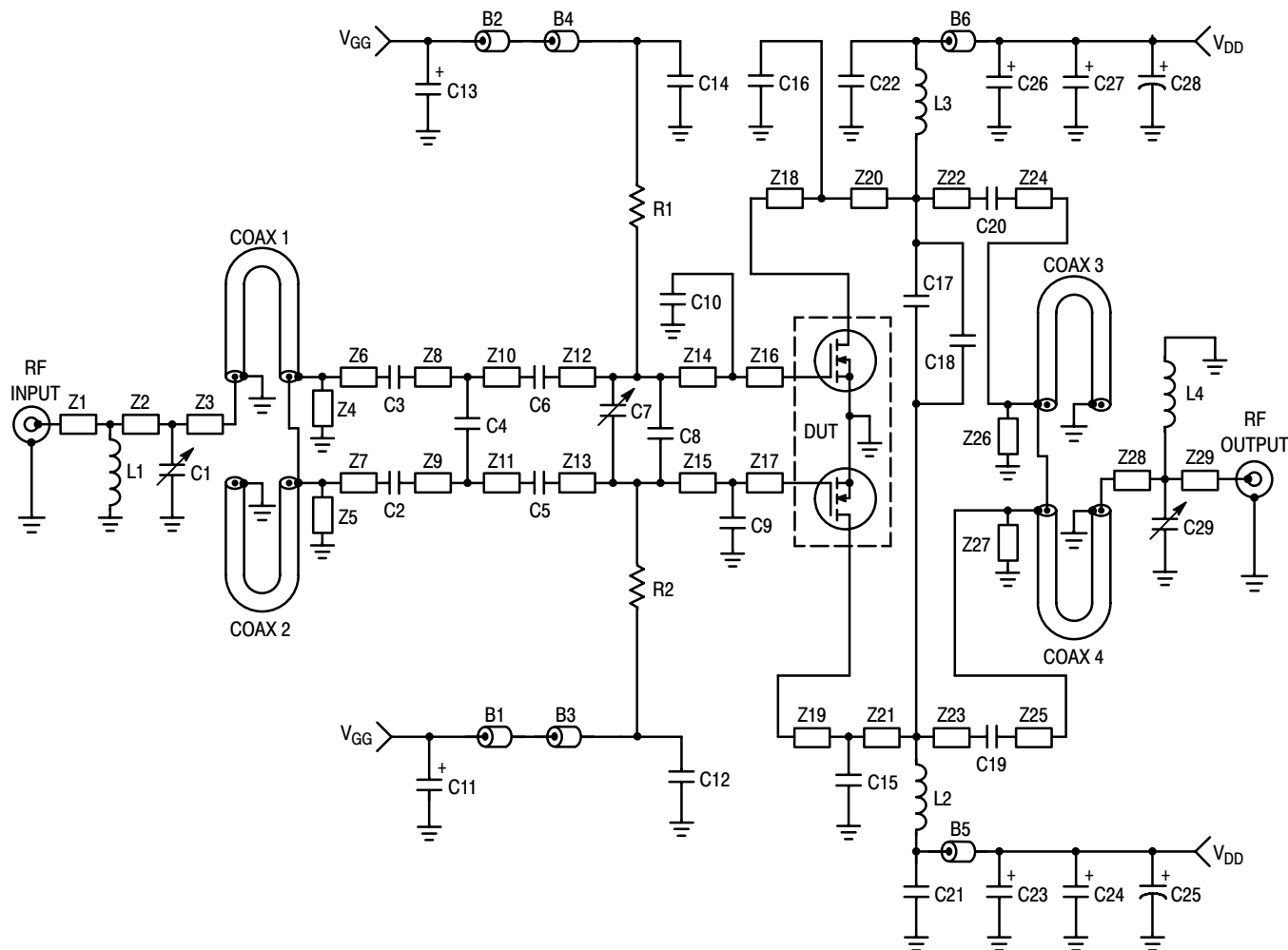

B1, B2, B5, B6	Long Ferrite Beads, Surface Mount	Z1	0.420" x 0.080" Microstrip
B3, B4	Short Ferrite Beads, Surface Mount	Z2	0.190" x 0.080" Microstrip
C1	0.6-4.5 pF Variable Capacitor	Z3	0.097" x 0.080" Microstrip
C2, C3, C5, C6, C12, C14, C19, C20, C21, C22	47 pF Chip Capacitors	Z4, Z5, Z26, Z27	2.170" x 0.080" Microstrip
C4, C9, C10, C15, C16	12 pF Chip Capacitors	Z6, Z7	0.075" x 0.080" Microstrip
C7	0.8-9.1 pF Variable Capacitor	Z8, Z9	0.088" x 0.220" Microstrip
C8	7.5 pF Chip Capacitor	Z10, Z11	0.088" x 0.220" Microstrip
C11, C13	10 μF, 35 V Tantalum Surface Mount Chip Capacitors	Z12, Z13	0.460" x 0.220" Microstrip
C17	3.6 pF Chip Capacitor	Z14, Z15	0.685" x 0.625" Microstrip
C18	5.1 pF Chip Capacitor	Z16, Z17	0.055" x 0.625" Microstrip
C23, C24, C26, C27	22 μF, 35 V Tantalum Surface Mount Chip Capacitors	Z18, Z19	0.055" x 0.632" Microstrip
C25, C28	220 μF, 50 V Electrolytic Capacitors	Z20, Z21	0.685" x 0.632" Microstrip
C29	0.4-2.5 pF Variable Capacitor	Z22, Z23	0.732" x 0.080" Microstrip
Coax1, Coax2	25 Ω, Semi Rigid Coax, 70 mil OD, 1.05" Long	Z24, Z25	0.060" x 0.080" Microstrip
Coax3, Coax4	50 Ω, Semi Rigid Coax, 85 mil OD, 1.05" Long	Z28	0.230" x 0.080" Microstrip
L1, L2, L3	18.5 nH Mini Spring Inductors, Coilcraft	Z29	0.460" x 0.080" Microstrip
L4	12.5 nH Mini Spring Inductor, Coilcraft	Board	30 mil Teflon®, εr = 2.55,
R1, R2	510 Ω, 1/10 W Chip Resistors	Material	Copper Clad, 2 oz Cu

Figure 1. 880 MHz Broadband Test Circuit Schematic

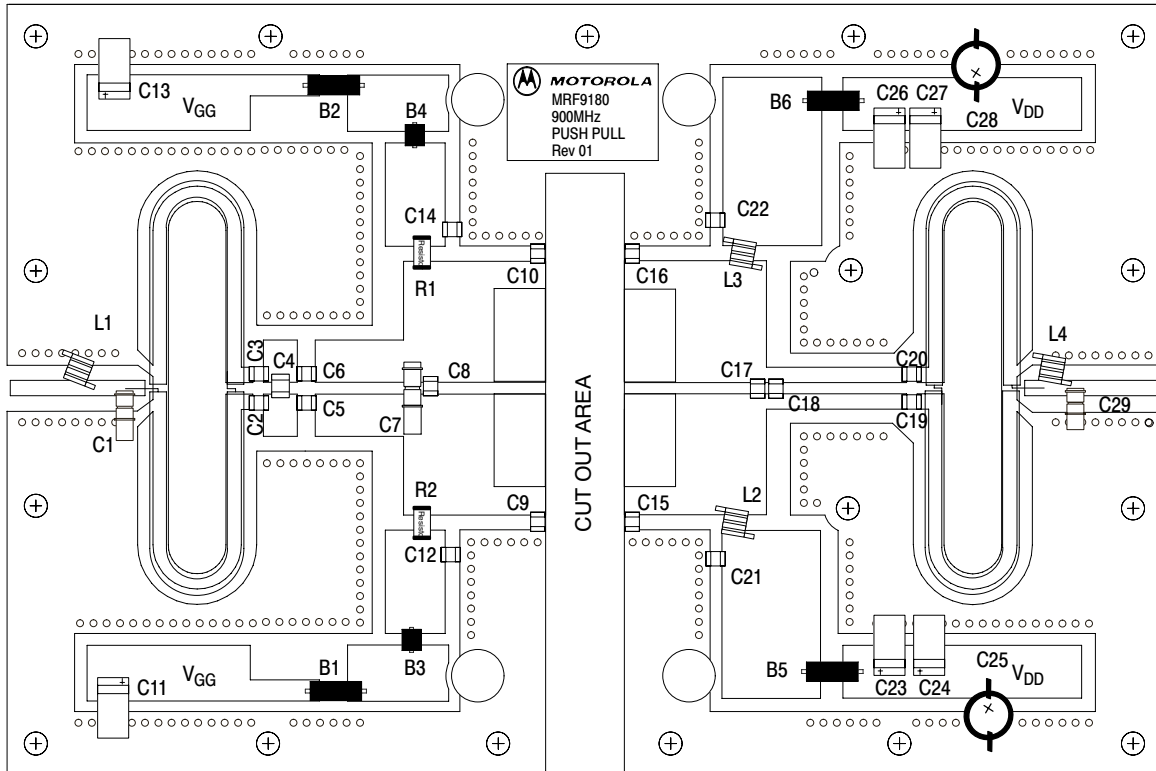

Freescale has begun the transition of marking Printed Circuit Boards (PCBs) with the Freescale Semiconductor signature/logo. PCBs may have either Motorola or Freescale markings during the transition period. These changes will have no impact on form, fit or function of the current product.

Figure 2. 880 MHz Broadband Test Circuit Component Layout

TYPICAL CHARACTERISTICS

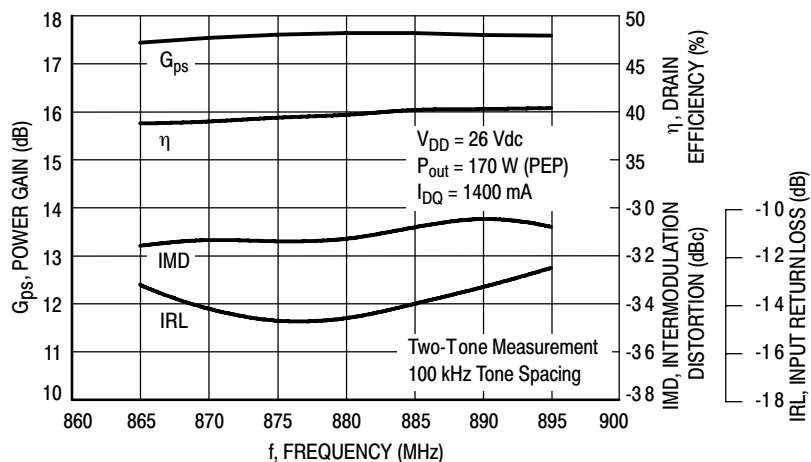

Figure 3. Class AB Broadband Circuit Performance

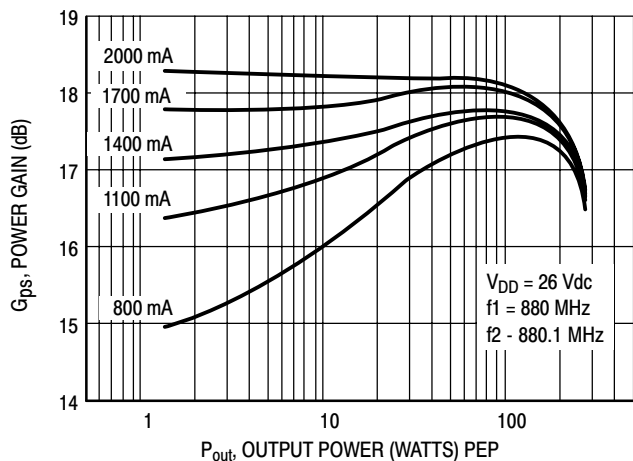

Figure 4. Power Gain versus Output Power

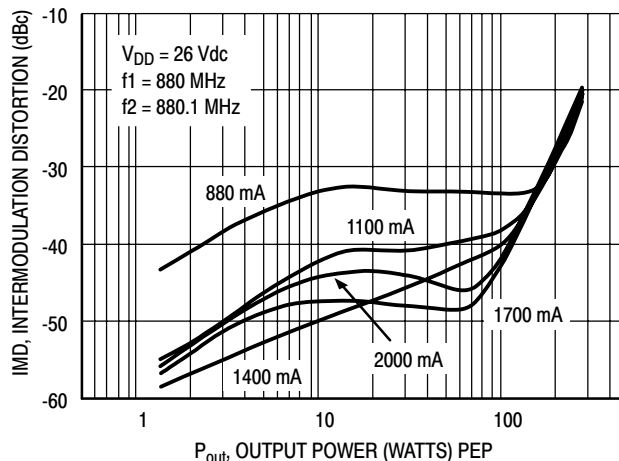

Figure 5. Intermodulation Distortion versus Output Power

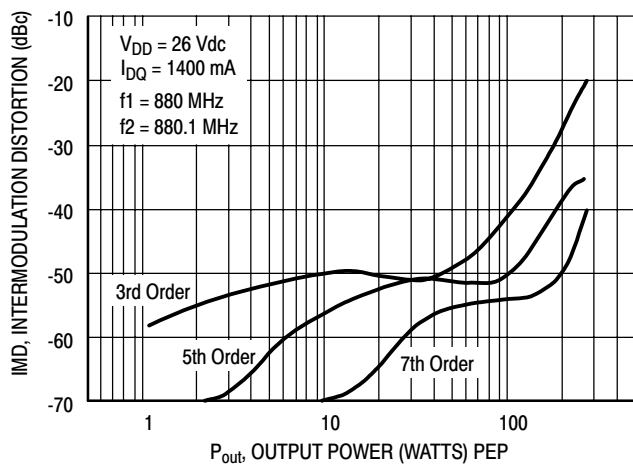

Figure 6. Intermodulation Distortion Products versus Output Power

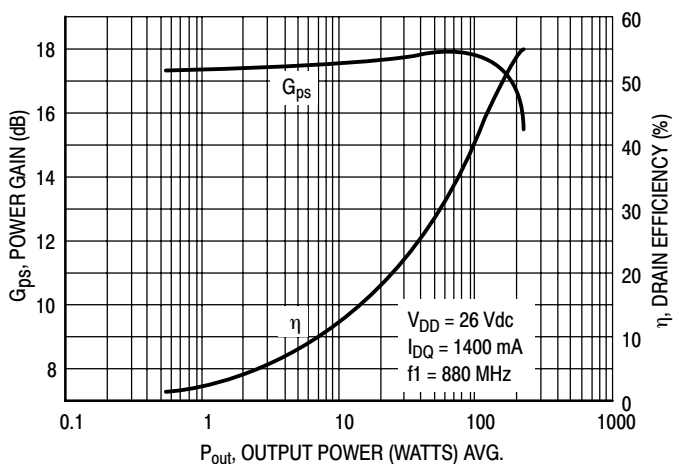

Figure 7. Power Gain and Efficiency versus Output Power

TYPICAL CHARACTERISTICS

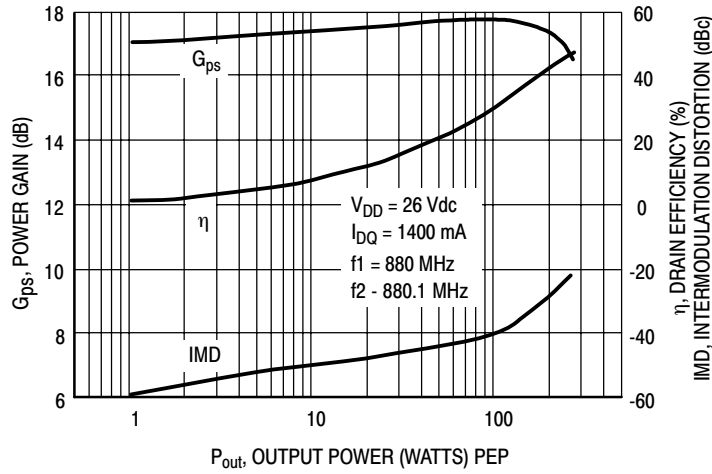

Figure 8. Power Gain, Efficiency and IMD versus Output Power

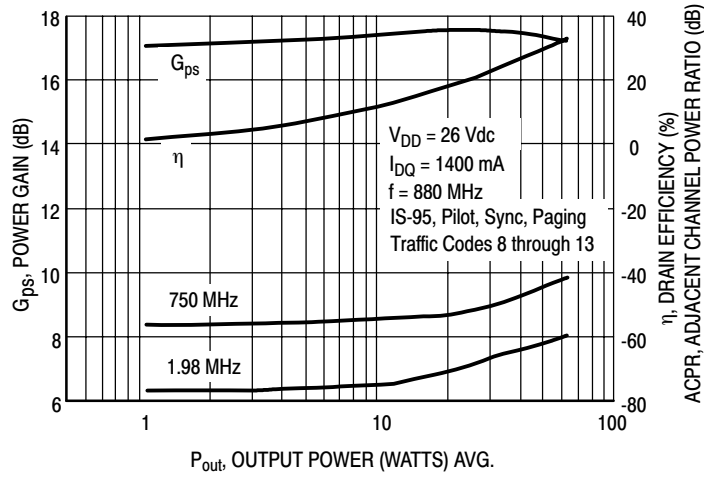
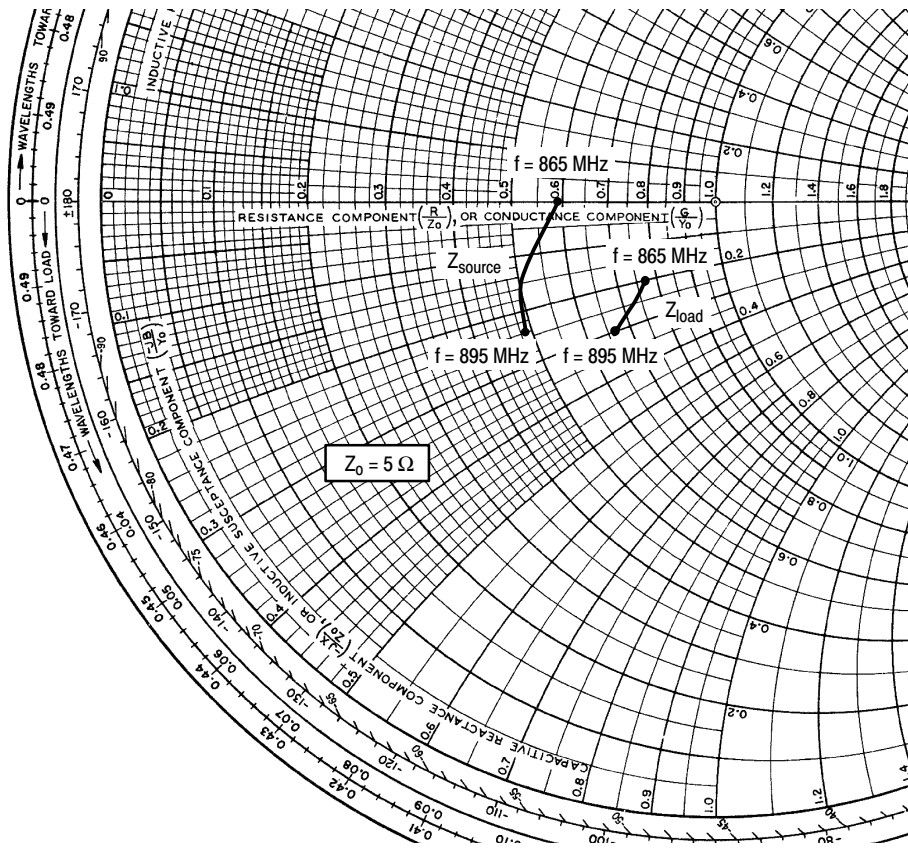

Figure 9. Power Gain, Efficiency and ACPR versus Output Power



$V_{DD} = 26 \text{ V}$, $I_{DQ} = 1400 \text{ mA}$, $P_{out} = 170 \text{ W PEP}$

f MHz	Z_{source} Ω	Z_{load} Ω
865	$2.95 - j0.00$	$3.83 - j1.02$
880	$2.48 - j0.67$	$3.55 - j1.38$
895	$2.44 - j1.18$	$3.34 - j1.51$

Z_{source} = Test circuit impedance as measured from gate to gate, balanced configuration.

Z_{load} = Test circuit impedance as measured from drain to drain, balanced configuration.

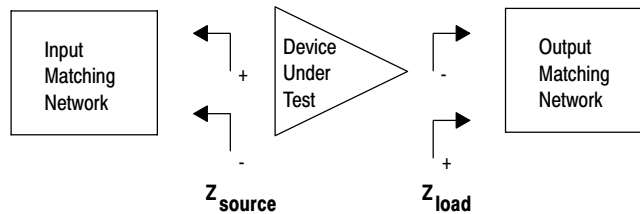
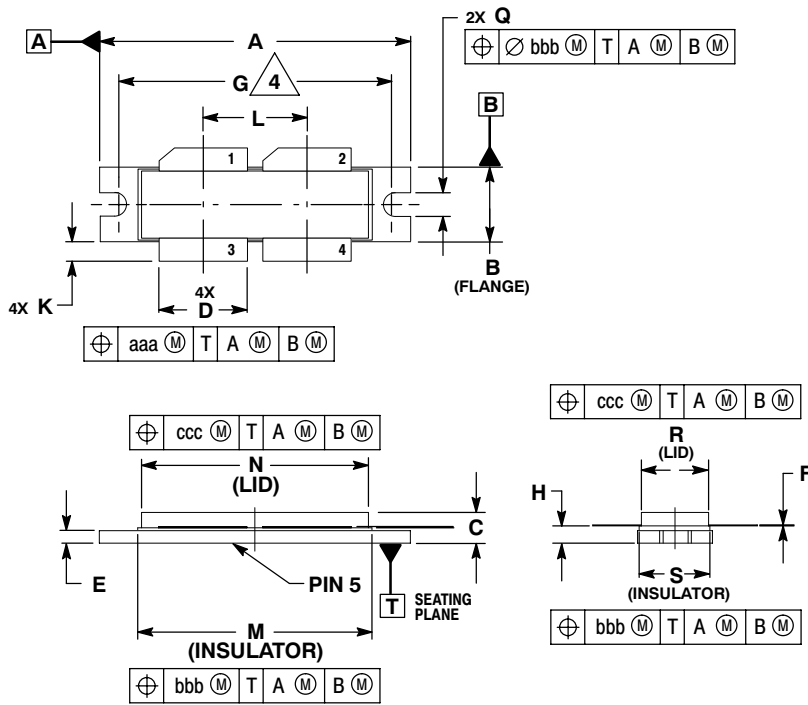

Figure 10. Series Equivalent Source and Load Impedance

PACKAGE DIMENSIONS



- NOTES:
1. INTERPRET DIMENSIONS AND TOLERANCES PER ASME Y14.5M-1994.
 2. CONTROLLING DIMENSION: INCH.
 3. DIMENSION H IS MEASURED 0.030 (0.762) AWAY FROM PACKAGE BODY.
 4. RECOMMENDED BOLT CENTER DIMENSION OF 1.52 (38.61) BASED ON M3 SCREW.

DIM	INCHES		MILLIMETERS	
	MIN	MAX	MIN	MAX
A	1.615	1.625	41.02	41.28
B	0.395	0.405	10.03	10.29
C	0.150	0.200	3.81	5.08
D	0.455	0.465	11.56	11.81
E	0.062	0.066	1.57	1.68
F	0.004	0.007	0.10	0.18
G	1.400 BSC		35.56 BSC	
H	0.082	0.090	2.08	2.29
K	0.117	0.137	2.97	3.48
L	0.540 BSC		13.72 BSC	
M	1.219	1.241	30.96	31.52
N	1.218	1.242	30.94	31.55
Q	0.120	0.130	3.05	3.30
R	0.355	0.365	9.01	9.27
S	0.365	0.375	9.27	9.53
aaa	0.013 REF		0.33 REF	
bbb	0.010 REF		0.25 REF	
ccc	0.020 REF		0.51 REF	

- STYLE 1:
 PIN 1. DRAIN
 2. DRAIN
 3. GATE
 4. GATE
 5. SOURCE

**CASE 375D-05
 ISSUE E
 NI-1230**

REVISION HISTORY

The following table summarizes revisions to this document.

Revision	Date	Description
10	Dec. 2009	<ul style="list-style-type: none">Data sheet archived. Part no longer manufactured.

ARCHIVE INFORMATION

ARCHIVE INFORMATION

How to Reach Us:

Home Page:

www.freescale.com

Web Support:

<http://www.freescale.com/support>

USA/Europe or Locations Not Listed:

Freescale Semiconductor, Inc.
Technical Information Center, EL516
2100 East Elliot Road
Tempe, Arizona 85284
1-800-521-6274 or +1-480-768-2130
www.freescale.com/support

Europe, Middle East, and Africa:

Freescale Halbleiter Deutschland GmbH
Technical Information Center
Schatzbogen 7
81829 Muenchen, Germany
+44 1296 380 456 (English)
+46 8 52200080 (English)
+49 89 92103 559 (German)
+33 1 69 35 48 48 (French)
www.freescale.com/support

Japan:

Freescale Semiconductor Japan Ltd.
Headquarters
ARCO Tower 15F
1-8-1, Shimo-Meguro, Meguro-ku,
Tokyo 153-0064
Japan
0120 191014 or +81 3 5437 9125
support.japan@freescale.com

Asia/Pacific:

Freescale Semiconductor China Ltd.
Exchange Building 23F
No. 118 Jianguo Road
Chaoyang District
Beijing 100022
China
+86 10 5879 8000
support.asia@freescale.com

For Literature Requests Only:

Freescale Semiconductor Literature Distribution Center
P.O. Box 5405
Denver, Colorado 80217
1-800-441-2447 or +1-303-675-2140
Fax: +1-303-675-2150
LDCForFreescaleSemiconductor@hibbertgroup.com

Information in this document is provided solely to enable system and software implementers to use Freescale Semiconductor products. There are no express or implied copyright licenses granted hereunder to design or fabricate any integrated circuits or integrated circuits based on the information in this document.

Freescale Semiconductor reserves the right to make changes without further notice to any products herein. Freescale Semiconductor makes no warranty, representation or guarantee regarding the suitability of its products for any particular purpose, nor does Freescale Semiconductor assume any liability arising out of the application or use of any product or circuit, and specifically disclaims any and all liability, including without limitation consequential or incidental damages. "Typical" parameters that may be provided in Freescale Semiconductor data sheets and/or specifications can and do vary in different applications and actual performance may vary over time. All operating parameters, including "Typicals", must be validated for each customer application by customer's technical experts. Freescale Semiconductor does not convey any license under its patent rights nor the rights of others. Freescale Semiconductor products are not designed, intended, or authorized for use as components in systems intended for surgical implant into the body, or other applications intended to support or sustain life, or for any other application in which the failure of the Freescale Semiconductor product could create a situation where personal injury or death may occur. Should Buyer purchase or use Freescale Semiconductor products for any such unintended or unauthorized application, Buyer shall indemnify and hold Freescale Semiconductor and its officers, employees, subsidiaries, affiliates, and distributors harmless against all claims, costs, damages, and expenses, and reasonable attorney fees arising out of, directly or indirectly, any claim of personal injury or death associated with such unintended or unauthorized use, even if such claim alleges that Freescale Semiconductor was negligent regarding the design or manufacture of the part.

Freescale™ and the Freescale logo are trademarks of Freescale Semiconductor, Inc. All other product or service names are the property of their respective owners.

© Freescale Semiconductor, Inc. 2006, 2008-2009. All rights reserved.