



SA12B5 SA16B3 / SA16B6

Application Specific Discretes
A.S.D.TM

SCHOTTKY ARRAYS

MAIN APPLICATIONS

Any electronic equipment where suitable bus termination is required to avoid signal reflections and distortions :

- PCs
- Workstations
- High frequency processor boards
- Dataline interface

DESCRIPTION

Dedicated to bus termination, the Schottky arrays SA12B5, SA16B3 and SA16B6 minimise stray emissions from PCB tracks. They provide suitable termination by avoiding signal reflexions and distortions.

FEATURES

- 12-BIT (SA12) OR 16-BIT (SA16) DUAL SCHOTTKY DIODE ARRAYS
- REVERSE VOLTAGE : $V_{RRM} = 7.5 \text{ V}$
- FORWARD VOLTAGE $V_F < 1.3 \text{ V}$

BENEFITS

- Provides impedance matching, and minimizes distortion.
- Lowers EMI / RFI radiation.
- Eliminates negative voltage : minimizes risk of latch-up for sensitive ICs.
- Saves valuable space on board.

COMPLIES WITH FOLLOWING STANDARD :

- MIL STD 883C - Method 3015-6 - class 3
- IEC1000-4-2 level 4

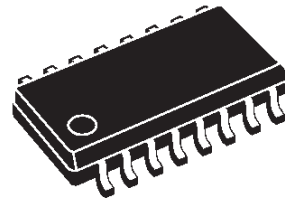

SO-16

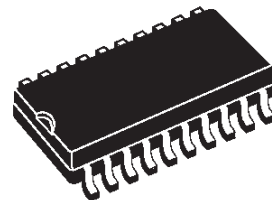

SO-20

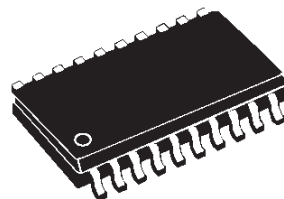

SSOP20

SA12B5 / SA16B3 / SA16B6

FUNCTIONAL DIAGRAM (SO-16)

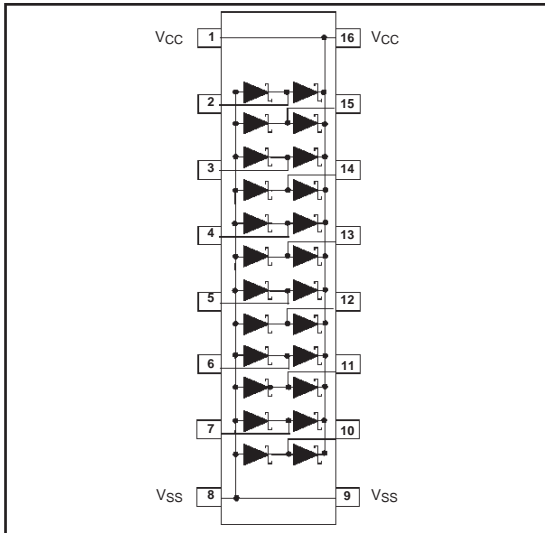

FUNCTIONAL DIAGRAM (SO-20 and SSOP20)

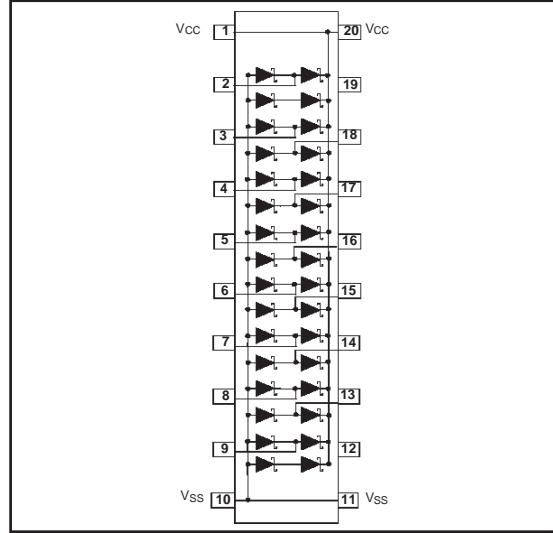

ABSOLUTE MAXIMUM RATINGS ($T_{amb} = 25\text{ }^{\circ}\text{C}$)

Symbol	Parameter and test conditions		Value	Unit
P	Power dissipation	SO-20 SO-16 and SSOP20	1250 850	mW
V _{OP}	Maximum operating voltage ($V_{CC} - V_{SS}$)		7.5	V
V _{PP}	Maximum electrostatic discharge MIL STD 883C - Method 3015-6 / IEC1000-4-2 contact		8	kV
T _{OP}	Operating temperature range (see note 1)		-40 to +85	°C
T _{stg}	Storage temperature range		-55 to +150	°C
T _L	Maximum lead temperature for soldering during 10s		260	°C
T _j	Maximum junction temperature		150	°C

Note 1: within the T_{OP} range, the SAxx keep on operating. The impacts of the ambient temperature are given by derating curves on the following page.

ELECTRICAL CHARACTERISTICS ($T_{amb} = 25\text{ }^{\circ}\text{C}$)

Symbol	Parameter and test conditions		Typ.	Max.	Unit
I _R	Leakage current @ $V_{RRM} = 7.5\text{ V}$			5	μA
V _F	Forward voltage (see note 2)	I _{PP} = 18 mA I _{PP} = 50 mA		1.05 1.3	V
C _d	Capacitance	V _{bias} = 0V, F = 1MHz		16	pF

Note 2: for both pull-up and pull-down schottky diodes.

THERMAL RESISTANCE

Symbol	Parameter	Packages	Value	Unit
R _{th(j-a)}	Junction to ambient	SO-16 and SSOP20 SO-20	140 100	°C/W

Fig1-1: Clamping forward voltage versus peak pulse current (typical values, low level).

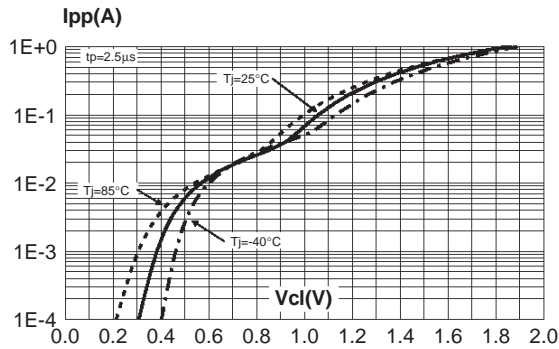

Fig1-2: Clamping forward voltage versus peak pulse current (typical values, high level).

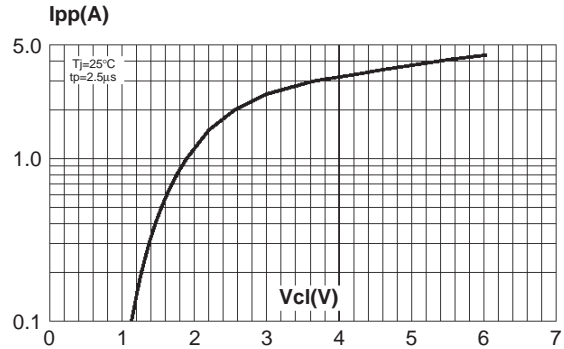

Fig 2: Leakage current versus junction temperature (typical values).

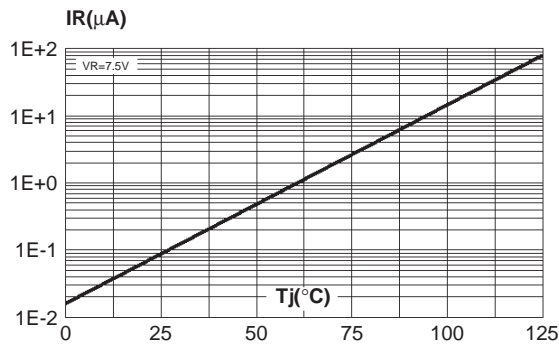

Fig 3: Non repetitive surge peak forward current versus pulse duration (rectangular waveform).

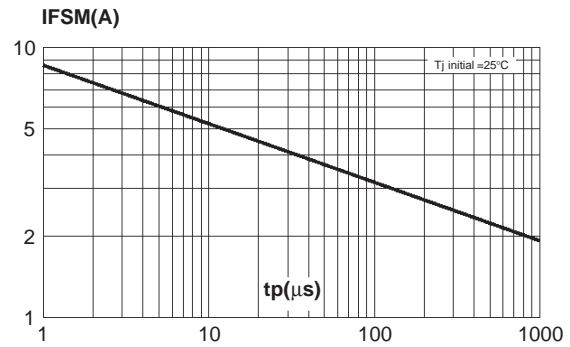

Fig 4: Non repetitive surge peak forward current versus initial junction temperature.

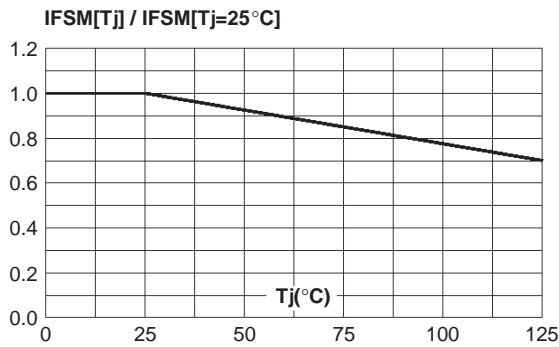
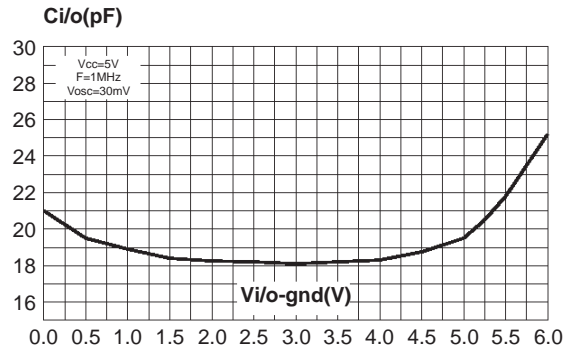
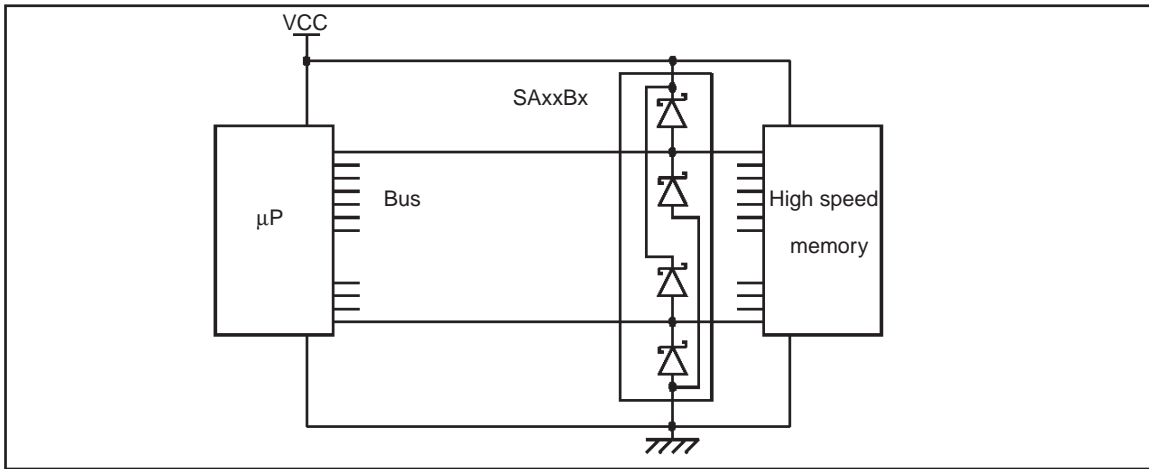

Fig 5: Capacitance between input or output and ground versus applied voltage (typical values).



SA12B5 / SA16B3 / SA16B6

TYPICAL APPLICATION



MARKING

Type	Package	Marking
SA12B5	SO16	SA12B5
SA16B3	SO20	SA16B3
SA16B6	SSOP20	SA16B6

PACKAGE MECHANICAL DATA

SO-16

REF.	DIMENSIONS					
	Millimeters			Inches		
	Min.	Typ.	Max.	Min.	Typ.	Max.
A			1.75			0.069
a1	0.1		0.20	0.004		0.008
a2			1.6			0.063
b	0.35		0.46	0.014		0.018
b1	0.19		0.25	0.007		0.010
C		0.5			0.020	
c1	45°(typ.)					
D	9.8		10	0.386		0.394
E	5.8		6.2	0.228		0.244
e		1.27			0.050	
e3		8.89			0.350	
F	3.8		4.0	0.150		0.158
G	4.6		5.3	0.181		0.209
L	0.5		1.27	0.020		0.050
M			0.75			0.030
S	8°(typ.)					

Weight : 0.160g

(1) Do not include mold flash or protrusions. Mold flash or protrusions shall not exceed 0.15mm (0.006inches)

PACKAGE MECHANICAL DATA
SO-20

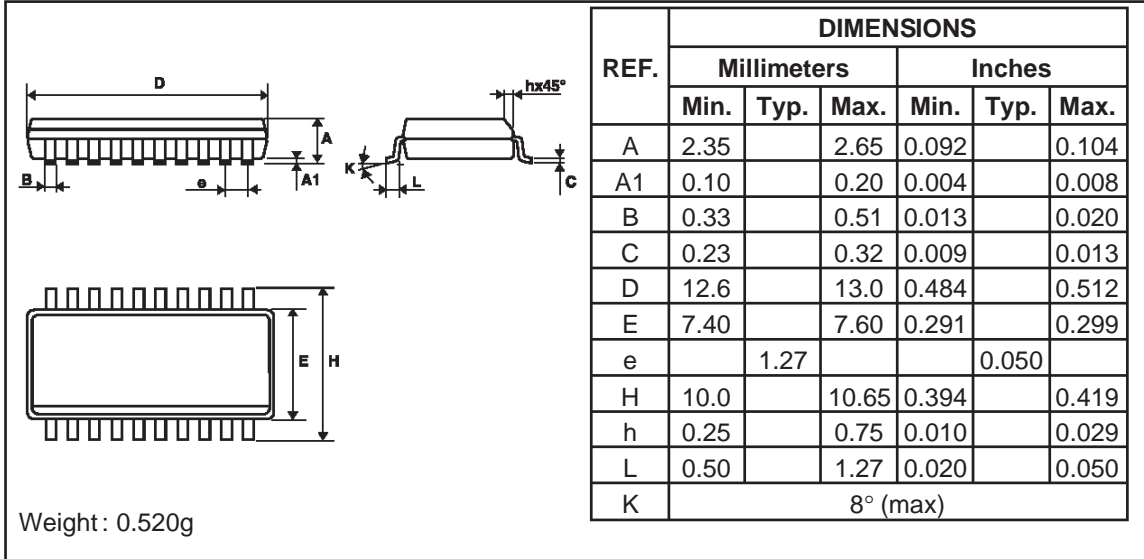

SSOP20

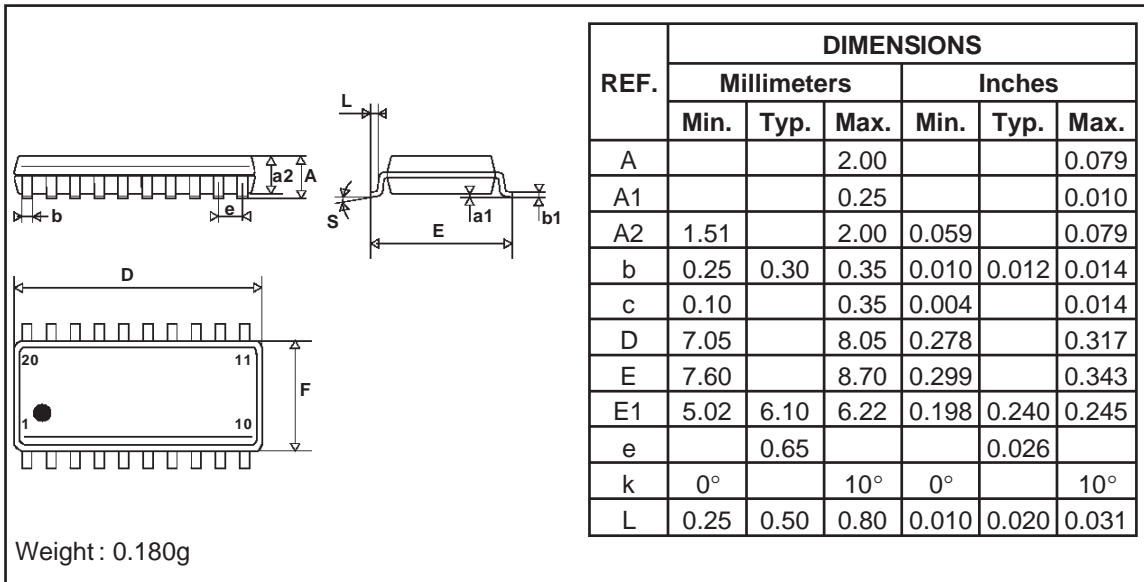

Information furnished is believed to be accurate and reliable. However, STMicroelectronics assumes no responsibility for the consequences of use of such information nor for any infringement of patents or other rights of third parties which may result from its use. No license is granted by implication or otherwise under any patent or patent rights of STMicroelectronics. Specifications mentioned in this publication are subject to change without notice. This publication supersedes and replaces all information previously supplied. STMicroelectronics products are not authorized for use as critical components in life support devices or systems without express written approval of STMicroelectronics.

The ST logo is a registered trademark of STMicroelectronics

© 1999 STMicroelectronics - Printed in Italy - All rights reserved.

STMicroelectronics GROUP OF COMPANIES

Australia - Brazil - Canada - China - France - Germany - Italy - Japan - Korea - Malaysia - Malta - Mexico - Morocco - The Netherlands - Singapore - Spain - Sweden - Switzerland - Taiwan - Thailand - United Kingdom - U.S.A.

<http://www.st.com>

