

TSOP, FP-BGA, TQFP
Commercial Temp
Industrial Temp

128K x 16

2Mb Asynchronous SRAM

7, 8, 10, 12 ns
3.3 V V_{DD}
Center V_{DD} and V_{SS}

Features

- Fast access time: 7, 8, 10, 12 ns
- CMOS low power operation: 145/125/100/85 mA at minimum cycle time
- Single 3.3 V power supply
- All inputs and outputs are TTL-compatible
- Byte control
- Fully static operation
- Industrial Temperature Option: -40° to 85°C
- Package line up
 - TP: 400 mil, 44-pin TSOP Type II package
 - GP: RoHS-compliant 400 mil, 44-pin TSOP Type II package
 - T: 10 mm x 10 mm, 44-pin TQFP
 - GT: RoHS-compliant 10 mm x 10 mm, 44-pin TQFP
 - U: 6 mm x 8 mm Fine Pitch Ball Grid Array package
 - GU: RoHS-compliant 6 mm x 8 mm Fine Pitch Ball Grid Array package

Description

The GS72116A is a high speed CMOS Static RAM organized as 131,072 words by 16 bits. Static design eliminates the need for external clocks or timing strobes. The GS operates on a single 3.3 V power supply and all inputs and outputs are TTL-compatible. The GS72116A is available in a 6 mm x 8 mm Fine Pitch BGA package, a 10 mm x 10 mm TQFP package, and 400 mil TSOP Type-II packages.

Pin Descriptions

Symbol	Description
A ₀ –A ₁₆	Address input
DQ ₁ –DQ ₁₆	Data input/output
$\overline{\text{CE}}$	Chip enable input
$\overline{\text{LB}}$	Lower byte enable input (DQ1 to DQ8)
$\overline{\text{UB}}$	Upper byte enable input (DQ9 to DQ16)
$\overline{\text{WE}}$	Write enable input
$\overline{\text{OE}}$	Output enable input
V_{DD}	+3.3 V power supply
V_{SS}	Ground
NC	No connect

44-Pin TQFP 128K x 16-Pin Configuration

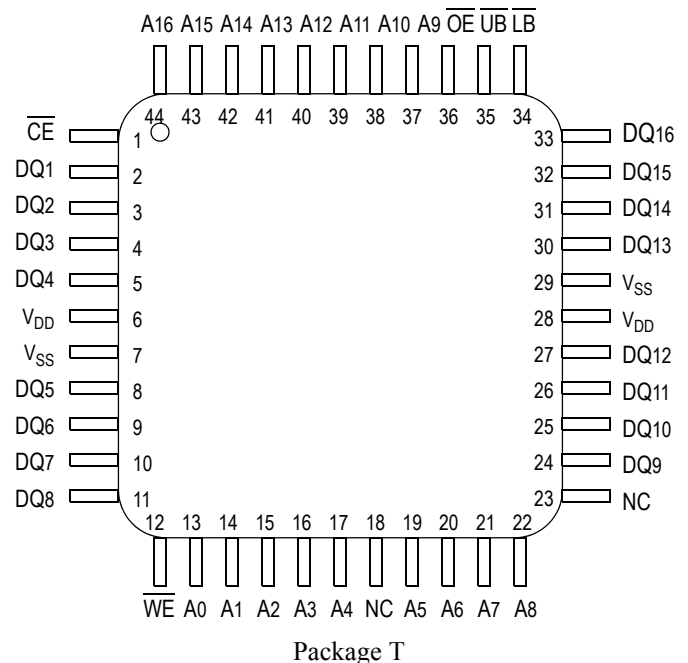

Fine Pitch BGA 128K x 16-Bump Configuration

	1	2	3	4	5	6
A	$\overline{\text{LB}}$	$\overline{\text{OE}}$	A0	A1	A2	NC
B	DQ16	$\overline{\text{UB}}$	A3	A4	$\overline{\text{CE}}$	DQ1
C	DQ14	DQ15	A5	A6	DQ2	DQ3
D	V _{SS}	DQ13	NC	A7	DQ4	V _{DD}
E	V _{DD}	DQ12	NC	A16	DQ5	V _{SS}
F	DQ11	DQ10	A8	A9	DQ7	DQ6
G	DQ9	NC	A10	A11	$\overline{\text{WE}}$	DQ8
H	NC	A12	A13	A14	A15	NC

6 mm x 8 mm, 0.75 mm Bump Pitch

Top View

Package U

TSOP-II 128K x 16-Pin Configuration

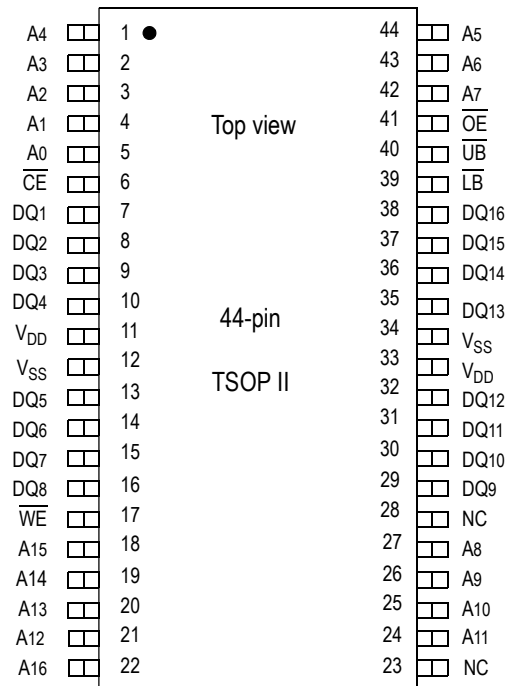

Package TP

Block Diagram

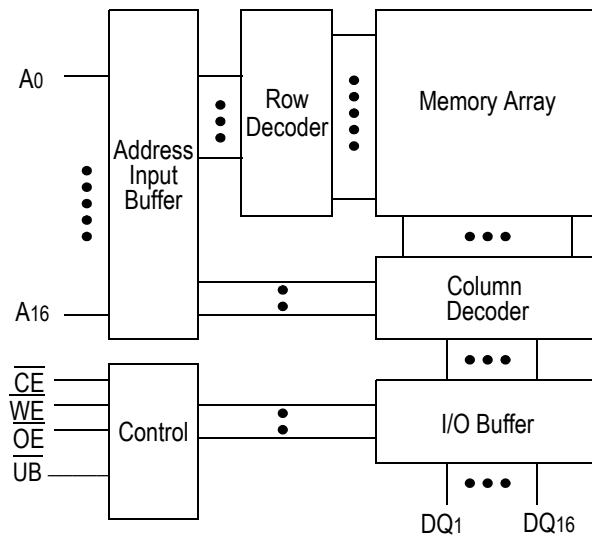

Truth Table

\overline{CE}	\overline{OE}	\overline{WE}	\overline{LB}	\overline{UB}	DQ1 to DQ8	DQ9 to DQ16	VDD Current
H	X	X	X	X	Not Selected	Not Selected	ISB1, ISB2
L	L	H	L	L	Read	Read	I _{DD}
			L	H	Read	High Z	
			H	L	High Z	Read	
L	X	L	L	L	Write	Write	
			L	H	Write	Not Write, High Z	
			H	L	Not Write, High Z	Write	
L	H	H	X	X	High Z	High Z	
L	X	X	H	H	High Z	High Z	

Note:

X: "H" or "L"

Absolute Maximum Ratings

Parameter	Symbol	Rating	Unit
Supply Voltage	V _{DD}	-0.5 to +4.6	V
Input Voltage	V _{IN}	-0.5 to V _{DD} +0.5 (≤ 4.6 V max.)	V
Output Voltage	V _{OUT}	-0.5 to V _{DD} +0.5 (≤ 4.6 V max.)	V
Allowable power dissipation	PD	0.7	W
Storage temperature	T _{STG}	-55 to 150	°C

Note:

Permanent device damage may occur if Absolute Maximum Ratings are exceeded. Functional operation shall be restricted to Recommended Operating Conditions. Exposure to higher than recommended voltages for extended periods of time could affect device reliability.

Recommended Operating Conditions

Parameter	Symbol	Min	Typ	Max	Unit
Supply Voltage for -7/-8/-10/12	V _{DD}	3.0	3.3	3.6	V
Input High Voltage	V _{IH}	2.0	—	V _{DD} +0.3	V
Input Low Voltage	V _{IL}	-0.3	—	0.8	V
Ambient Temperature, Commercial Range	T _{Ac}	0	—	70	°C
Ambient Temperature, Industrial Range	T _{AI}	-40	—	85	°C

Notes:

1. Input overshoot voltage should be less than V_{DD} +2 V and not exceed 20 ns.
2. Input undershoot voltage should be greater than -2 V and not exceed 20 ns.

Capacitance

Parameter	Symbol	Test Condition	Max	Unit
Input Capacitance	C _{IN}	V _{IN} = 0 V	5	pF
Output Capacitance	C _{OUT}	V _{OUT} = 0 V	7	pF

Notes:

1. Tested at T_A = 25°C, f = 1 MHz
2. These parameters are sampled and are not 100% tested.

DC I/O Pin Characteristics

Parameter	Symbol	Test Conditions	Min	Max
Input Leakage Current	I_{IL}	$V_{IN} = 0$ to V_{DD}	-1 μ A	1 μ A
Output Leakage Current	I_{LO}	Output High Z $V_{OUT} = 0$ to V_{DD}	-1 μ A	1 μ A
Output High Voltage	V_{OH}	$I_{OH} = -4$ mA	2.4	—
Output Low Voltage	V_{OL}	$I_{LO} = +4$ mA	—	0.4 V

Power Supply Currents

Parameter	Symbol	Test Conditions	0 to 70°C				-40 to 85°C			
			7 ns	8 ns	10 ns	12 ns	7 ns	8 ns	10 ns	12 ns
Operating Supply Current	$I_{DD} (max)$	$\overline{CE} \leq V_{IL}$ All other inputs $\geq V_{IH}$ or $\leq V_{IL}$ Min. cycle time $I_{OUT} = 0$ mA	145 mA	125 mA	100 mA	85 mA	150 mA	130 mA	105 mA	90 mA
Standby Current	$ISB1 (max)$	$\overline{CE} \geq V_{IH}$ All other inputs $\geq V_{IH}$ or $\leq V_{IL}$ Min. cycle time	25 mA	20 mA	20 mA	15 mA	30 mA	25 mA	25 mA	20 mA
Standby Current	$ISB2 (max)$	$\overline{CE} \geq V_{DD} - 0.2$ V All other inputs $\geq V_{DD} - 0.2$ V or ≤ 0.2 V	5 mA				10 mA			

AC Test Conditions

Parameter	Conditions
Input high level	$V_{IH} = 2.4 \text{ V}$
Input low level	$V_{IL} = 0.4 \text{ V}$
Input rise time	$t_r = 1 \text{ V/ns}$
Input fall time	$t_f = 1 \text{ V/ns}$
Input reference level	1.4 V
Output reference level	1.4 V
Output load	Fig. 1 & 2

Notes:

1. Include scope and jig capacitance.
2. Test conditions as specified with output loading as shown in **Fig. 1** unless otherwise noted.
3. Output load 2 for t_{LZ} , t_{HZ} , t_{OLZ} and t_{OHZ}

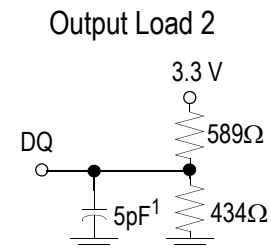
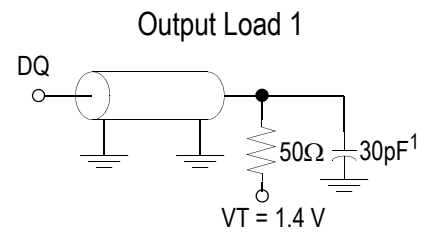

AC Characteristics

Read Cycle

Parameter	Symbol	-7		-8		-10		-12		Unit
		Min	Max	Min	Max	Min	Max	Min	Max	
Read cycle time	t _{RC}	7	—	8	—	10	—	12	—	ns
Address access time	t _{AA}	—	7	—	8	—	10	—	12	ns
Chip enable access time (\overline{CE})	t _{AC}	—	7	—	8	—	10	—	12	ns
Byte enable access time (\overline{UB} , \overline{LB})	t _{AB}	—	3	—	3.5	—	4	—	5	ns
Output enable to output valid (\overline{OE})	t _{OE}	—	3	—	3.5	—	4	—	5	ns
Output hold from address change	t _{OH}	3	—	3	—	3	—	3	—	ns
Chip enable to output in low Z (\overline{CE})	t _{LZ} *	3	—	3	—	3	—	3	—	ns
Output enable to output in low Z (\overline{OE})	t _{OLZ} *	0	—	0	—	0	—	0	—	ns
Byte enable to output in low Z (\overline{UB} , \overline{LB})	t _{BLZ} *	0	—	0	—	0	—	0	—	ns
Chip disable to output in High Z (\overline{CE})	t _{HZ} *	—	3.5	—	4	—	5	—	6	ns
Output disable to output in High Z (\overline{OE})	t _{OHZ} *	—	3	—	3.5	—	4	—	5	ns
Byte disable to output in High Z (\overline{UB} , \overline{LB})	t _{BHZ} *	—	3	—	3.5	—	4	—	5	ns

* These parameters are sampled and are not 100% tested.

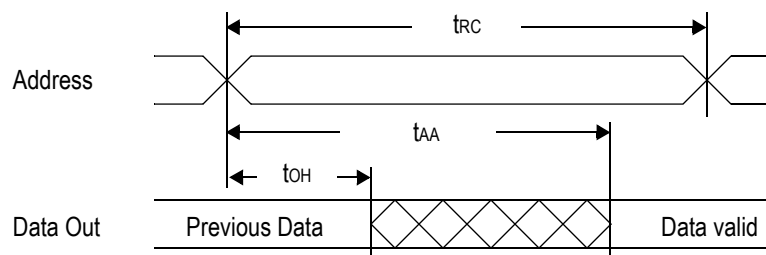
 Read Cycle 1: $\overline{CE} = \overline{OE} = V_{IL}$, $\overline{WE} = V_{IH}$, \overline{UB} and, or $\overline{LB} = V_{IL}$

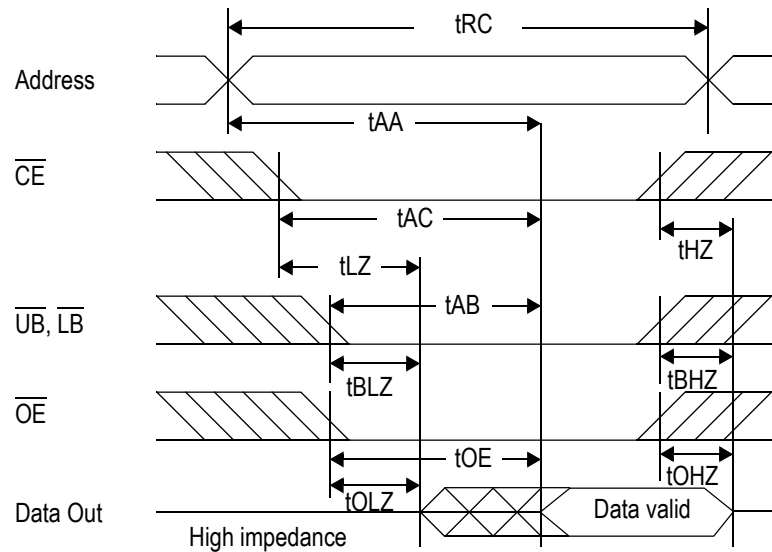
Read Cycle 2: $\overline{WE} = V_{IH}$

Write Cycle

Parameter	Symbol	-7		-8		-10		-12		Unit
		Min	Max	Min	Max	Min	Max	Min	Max	
Write cycle time	t_{WC}	7	—	8	—	10	—	12	—	ns
Address valid to end of write	t_{AW}	5	—	5.5	—	7	—	8	—	ns
Chip enable to end of write	t_{CW}	5	—	5.5	—	7	—	8	—	ns
Byte enable to end of write	t_{BW}	5	—	5.5	—	7	—	8	—	ns
Data set up time	t_{DW}	3.5	—	4	—	5	—	6	—	ns
Data hold time	t_{DH}	0	—	0	—	0	—	0	—	ns
Write pulse width	t_{WP}	5	—	5.5	—	7	—	8	—	ns
Address set up time	t_{AS}	0	—	0	—	0	—	0	—	ns
Write recovery time (\overline{WE})	t_{WR}	0	—	0	—	0	—	0	—	ns
Write recovery time (\overline{CE})	t_{WR1}	0	—	0	—	0	—	0	—	ns
Output Low Z from end of write	t_{WLZ}^*	3	—	3	—	3	—	3	—	ns
Write to output in High Z	t_{WHZ}^*	—	3	—	3.5	—	4	—	5	ns

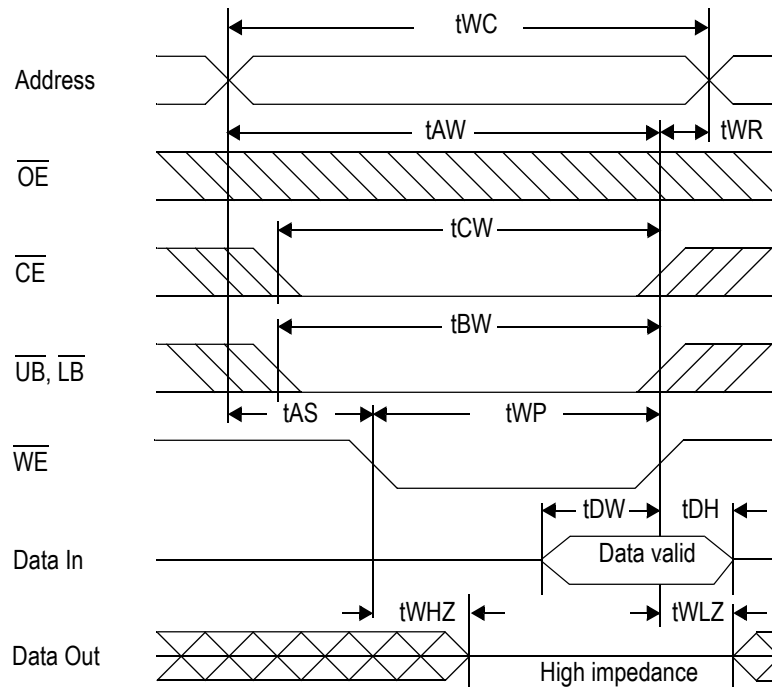
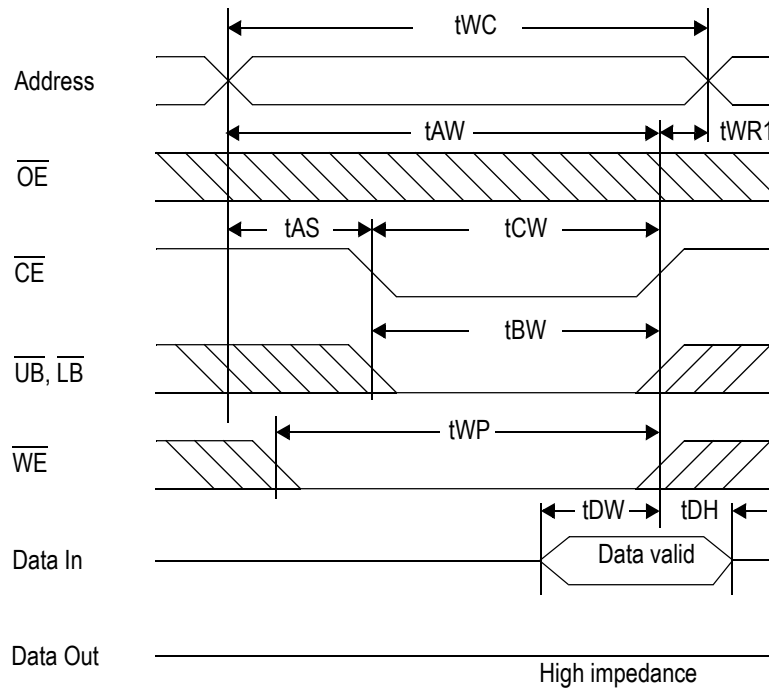
* These parameters are sampled and are not 100% tested.

Write Cycle 1: \overline{WE} control

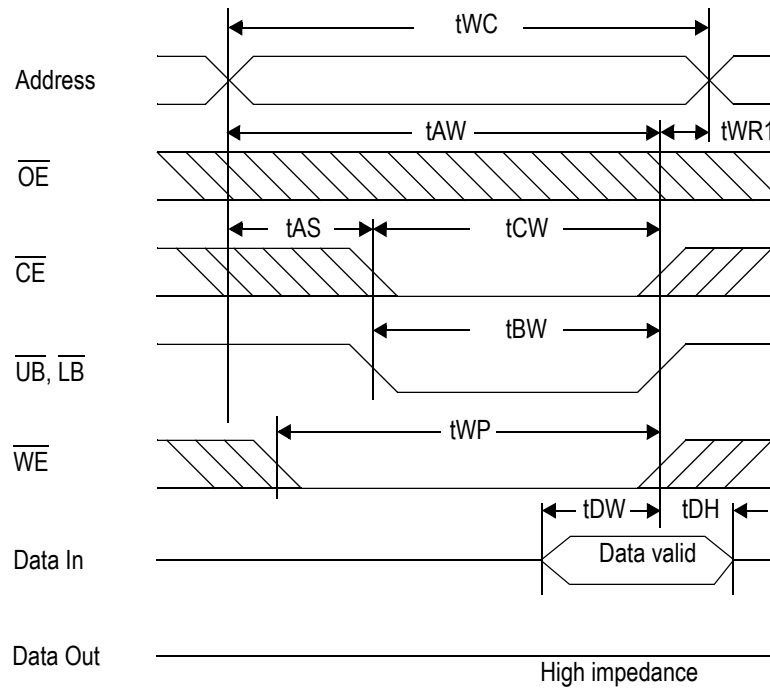
Write Cycle 2: \overline{CE} control

Write Cycle 3: \overline{UB} , \overline{LB} control

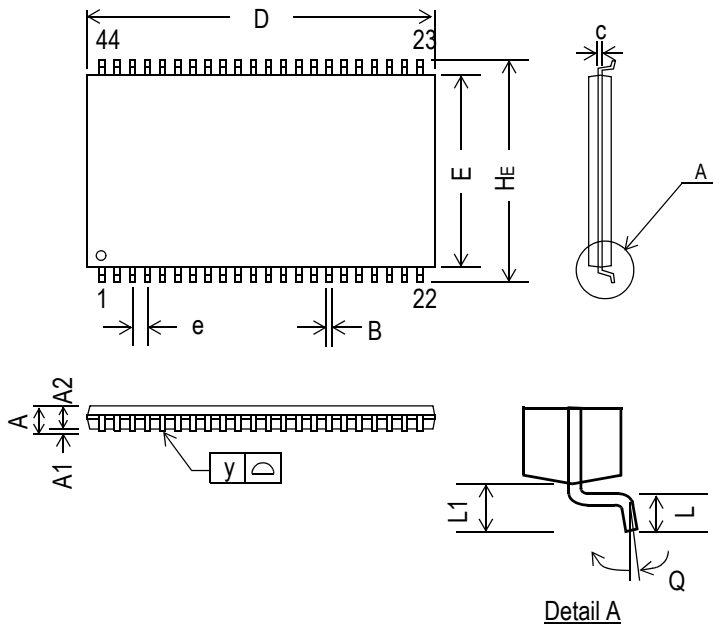

44-Pin, 400 mil TSOP-II

Symbol	Dimension in inch			Dimension in mm		
	min	nom	max	min	nom	max
A	—	—	0.047	—	—	1.20
A1	0.002	—	—	0.05	—	—
A2	0.037	0.039	0.041	0.95	1.00	1.05
B	0.01	0.014	0.018	0.25	0.35	0.45
c	—	0.006	—	—	0.15	—
D	0.721	0.725	0.729	18.31	18.41	18.51
E	0.396	0.400	0.404	10.06	10.16	10.26
e	—	0.031	—	—	0.80	—
H _E	0.455	0.463	0.471	11.56	11.76	11.96
L	0.016	0.020	0.024	0.40	0.50	0.60
L1	—	0.031	—	—	0.80	—
y	—	—	0.004	—	—	0.10
Q	0°	—	5°	0°	—	5°

Notes:

1. Dimension D & E do not include interlead flash.
2. Dimension B does not include dambar protrusion/intrusion.
3. Controlling dimension: mm

44-Pin TQFP (LQFP) Package

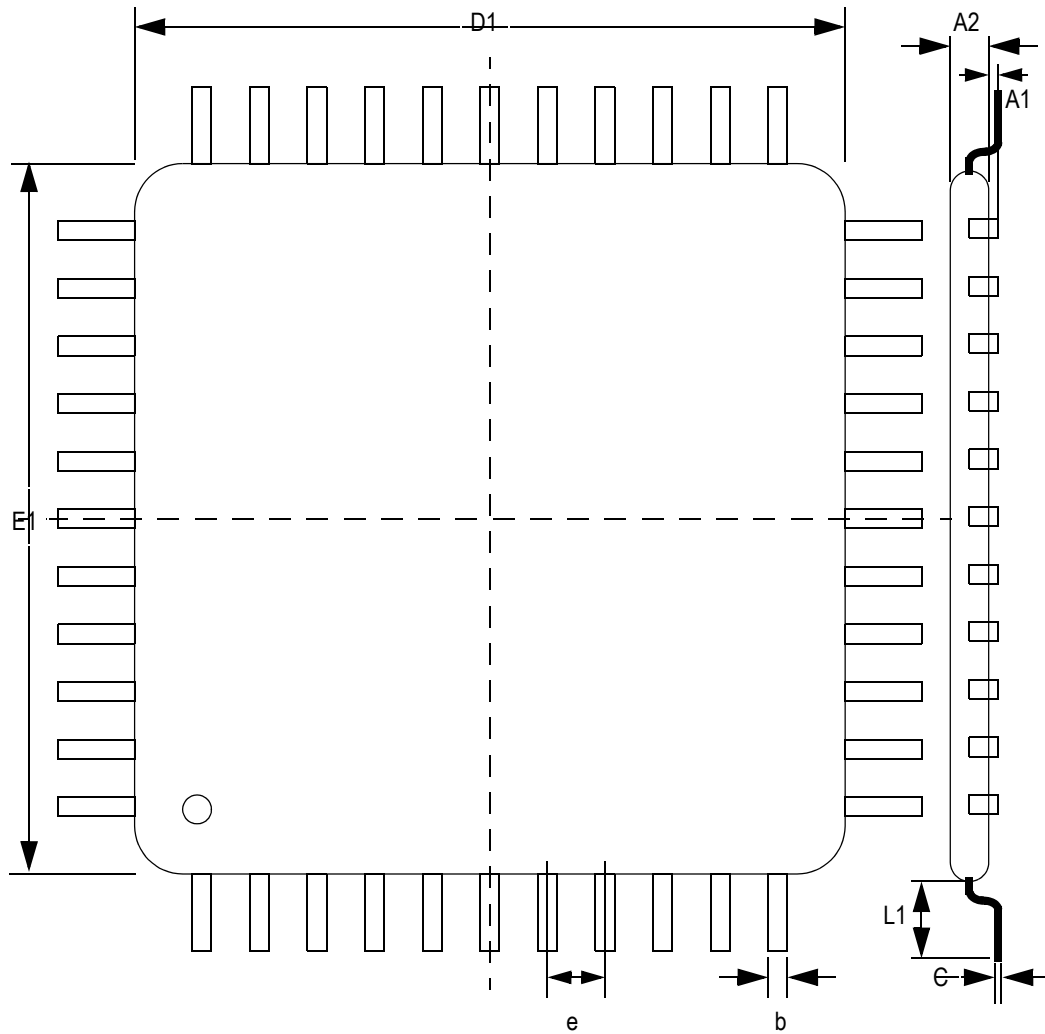

Body Size		Lead Count	Standoff	Body Thickness	Lead Length	Lead Width	Lead Thickness	Lead Pitch
E1	D1		A1	A2	L1	b	c	e
10	10	44	0.1	1.4	1.0	0.3	0.127	0.8

Units: mm

6 mm x 8 mm Fine Pitch BG

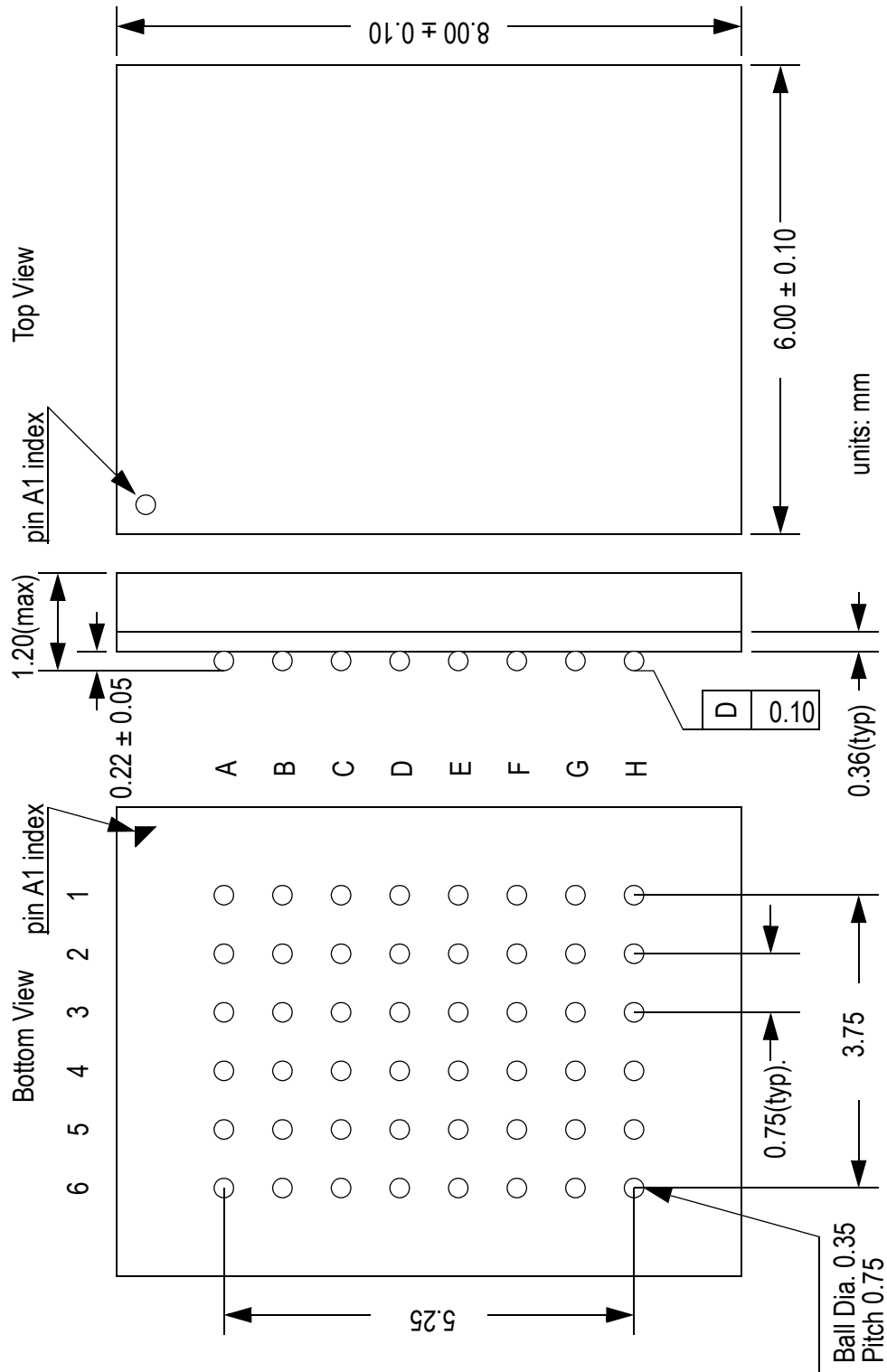

Ordering Information

Part Number*	Package	Access Time	Temp. Range
GS72116ATP-7	400 mil TSOP-II	7 ns	Commercial
GS72116ATP-8	400 mil TSOP-II	8 ns	Commercial
GS72116ATP-10	400 mil TSOP-II	10 ns	Commercial
GS72116ATP-12	400 mil TSOP-II	12 ns	Commercial
GS72116ATP-7I	400 mil TSOP-II	7 ns	Industrial
GS72116ATP-8I	400 mil TSOP-II	8 ns	Industrial
GS72116ATP-10I	400 mil TSOP-II	10 ns	Industrial
GS72116ATP-12I	400 mil TSOP-II	12 ns	Industrial
GS72116AGP-7	RoHS-compliant 400 mil TSOP-II	7 ns	Commercial
GS72116AGP-8	RoHS-compliant 400 mil TSOP-II	8 ns	Commercial
GS72116AGP-10	RoHS-compliant 400 mil TSOP-II	10 ns	Commercial
GS72116AGP-12	RoHS-compliant 400 mil TSOP-II	12 ns	Commercial
GS72116AGP-7I	RoHS-compliant 400 mil TSOP-II	7 ns	Industrial
GS72116AGP-8I	RoHS-compliant 400 mil TSOP-II	8 ns	Industrial
GS72116AGP-10I	RoHS-compliant 400 mil TSOP-II	10 ns	Industrial
GS72116AGP-12I	RoHS-compliant 400 mil TSOP-II	12 ns	Industrial
GS72116AT-7	44-pin TQFP	7 ns	Commercial
GS72116AT-8	44-pin TQFP	8 ns	Commercial
GS72116AT-10	44-pin TQFP	10 ns	Commercial
GS72116AT-12	44-pin TQFP	12 ns	Commercial
GS72116AT-7I	44-pin TQFP	7 ns	Industrial
GS72116AT-8I	44-pin TQFP	8 ns	Industrial
GS72116AT-10I	44-pin TQFP	10 ns	Industrial
GS72116AT-12I	44-pin TQFP	12 ns	Industrial
GS72116AGT-7	RoHS-compliant 44-pin TQFP	7 ns	Commercial
GS72116AGT-8	RoHS-compliant 44-pin TQFP	8 ns	Commercial
GS72116AGT-10	RoHS-compliant 44-pin TQFP	10 ns	Commercial
GS72116AGT-12	RoHS-compliant 44-pin TQFP	12 ns	Commercial

Notes:

- Customers requiring delivery in Tape and Reel should add the character "T" to the end of the part number. For example: GS72116TP-8T.

Ordering Information

Part Number*	Package	Access Time	Temp. Range
GS72116AGT-7I	RoHS-compliant 44-pin TQFP	7 ns	Industrial
GS72116AGT-8I	RoHS-compliant 44-pin TQFP	8 ns	Industrial
GS72116AGT-10I	RoHS-compliant 44-pin TQFP	10 ns	Industrial
GS72116AGT-12I	RoHS-compliant 44-pin TQFP	12 ns	Industrial
GS72116AU-7	6 mm x 8 mm Fine Pitch BGA	7 ns	Commercial
GS72116AU-8	6 mm x 8 mm Fine Pitch BGA	8 ns	Commercial
GS72116AU-10	6 mm x 8 mm Fine Pitch BGA	10 ns	Commercial
GS72116AU-12	6 mm x 8 mm Fine Pitch BGA	12 ns	Commercial
GS72116AU-7I	6 mm x 8 mm Fine Pitch BGA	7 ns	Industrial
GS72116AU-8I	6 mm x 8 mm Fine Pitch BGA	8 ns	Industrial
GS72116AU-10I	6 mm x 8 mm Fine Pitch BGA	10 ns	Industrial
GS72116AU-12I	6 mm x 8 mm Fine Pitch BGA	12 ns	Industrial
GS72116AGU-7	RoHS-compliant 6 mm x 8 mm Fine Pitch BGA	7 ns	Commercial
GS72116AGU-8	RoHS-compliant 6 mm x 8 mm Fine Pitch BGA	8 ns	Commercial
GS72116AGU-10	RoHS-compliant 6 mm x 8 mm Fine Pitch BGA	10 ns	Commercial
GS72116AGU-12	RoHS-compliant 6 mm x 8 mm Fine Pitch BGA	12 ns	Commercial
GS72116AGU-7I	RoHS-compliant 6 mm x 8 mm Fine Pitch BGA	7 ns	Industrial
GS72116AGU-8I	RoHS-compliant 6 mm x 8 mm Fine Pitch BGA	8 ns	Industrial
GS72116AGU-10I	RoHS-compliant 6 mm x 8 mm Fine Pitch BGA	10 ns	Industrial
GS72116AGU-12I	RoHS-compliant 6 mm x 8 mm Fine Pitch BGA	12 ns	Industrial

Notes:

- Customers requiring delivery in Tape and Reel should add the character "T" to the end of the part number. For example: GS72116TP-8T.

2Mb Asynchronous Datasheet Revision History

Rev. Code: Old; New	Types of Changes Format or Content	Revisions
72116A_r1		• Creation of new datasheet
72116A_r1; 72116A_r1_01	Content	• Added 6 ns speed bin to entire document
72116A_r1_01; 72116A_r1_02	Content	• Updated all power numbers • Changed 6 mm x 10 mm FP_BGA package designator from U to X
72116A_r1_02; 72116A_r1_03	Content	• Updated Recommended Operating Conditions table on page 5 • Removed 15 ns bin • Changed FPBGA package from 6 x 10 to 6 x 8 (package U)
72116A_r1_03; 72116A_r1_04	Content	• Removed 6 ns speed bin from entire document • Added 7 ns speed bin to entire document
72116A_r1_04; 72116A_r1_05	Content	• Corrected title of 6 x 8 FPBGA mechanical drawing
72116A_r1_05; 72116A_r1_06	Content/Format	• Updated format • Added RoHS-compliant information for TSOP-II package
72116A_r1_06; 72116A_r1_07	Content	• Added RoHS-compliant information for TQFP and FP-BGA packages
72116A_r1_07; 72116A_r1_08	Content	• Added RoHS-compliant 400 mil SOJ
72116A_r1_08; 72116A_r1_09	Content	• Updated to MP in ordering information table • Removed Status Column from Ordering Information table, removed references to SOJ