

LP2995

DDR Termination Regulator

General Description

The LP2995 linear regulator is designed to meet the JEDEC SSTL-2 and SSTL-3 specifications for termination of DDR-SDRAM. The device contains a high-speed operational amplifier to provide excellent response to load transients. The output stage prevents shoot through while delivering 1.5A continuous current and transient peaks up to 3A in the application as required for DDR-SDRAM termination. The LP2995 also incorporates a V_{SENSE} pin to provide superior load regulation and a V_{REF} output as a reference for the chipset and DDR DIMMS.

Patents Pending

Features

- Low output voltage offset
- Works with +5v, +3.3v and 2.5v rails
- Source and sink current
- Low external component count
- No external resistors required
- Linear topology
- Available in SO-8, PSOP-8 or LLP-16 packages
- Low cost and easy to use

Applications

- DDR Termination Voltage
- SSTL-2
- SSTL-3

Typical Application Circuit

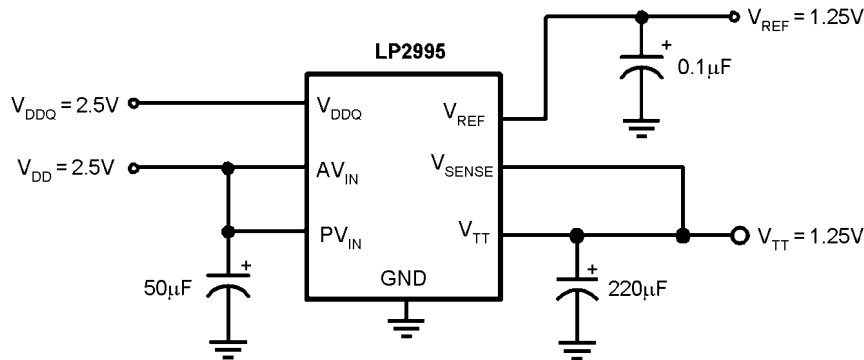

20039302

Connection Diagrams

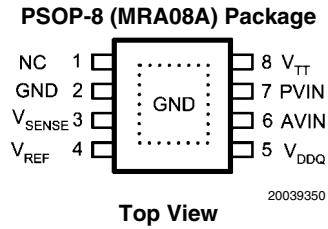
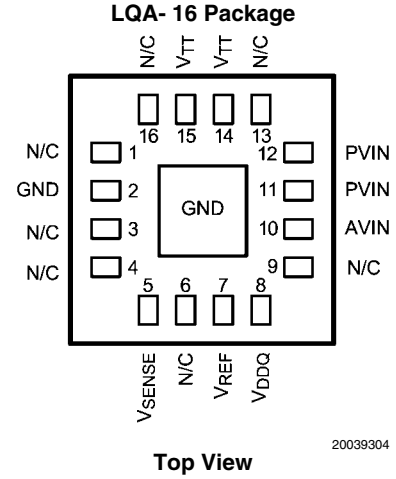
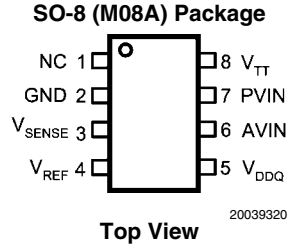

Pin Descriptions

SO-8 Pin or PSOP-8 Pin	LLP Pin	Name	Function
1	1,3,4,6,9, 13,16	NC	No internal connection. Can be used for vias.
2	2	GND	Ground.
3	5	VSENSE	Feedback pin for regulating VTT.
4	7	VREF	Buffered internal reference voltage of VDDQ/2.
5	8	VDDQ	Input for internal reference equal to VDDQ/2.
6	10	AVIN	Analog input pin.
7	11, 12	PVIN	Power input pin.
8	14, 15	VTT	Output voltage for connection to termination resistors.
	EP	EP	Exposed pad thermal connection. Connect to soft Ground.

Ordering Information

Order Number	Package Type	NSC Package Drawing	Supplied As
LP2995M	SO-8	M08A	95 Units per Rail
LP2995MX	SO-8	M08A	2500 Units Tape and Reel
LP2995MR	PSOP-8	MRA08A	95 Units per Rail
LP2995MRX	PSOP-8	MRA08A	2500 Units Tape and Reel
LP2995LQ	LLP-16	LQA16A	1000 Units Tape and Reel
LP2995LQX	LLP-16	LQA16A	4500 Units Tape and Reel

Absolute Maximum Ratings *(Note 1)*

If Military/Aerospace specified devices are required, please contact the National Semiconductor Sales Office/Distributors for availability and specifications.

AVIN to GND	-0.3V to +6V
PVIN to GND	-0.3V to AVIN
VDDQ <i>(Note 2)</i>	-0.3V to +6V
Storage Temp. Range	-65°C to +150°C
Junction Temperature	150°C
PSOP-8 Thermal Resistance (θ_{JA})	43°C/W

SO-8 Thermal Resistance (θ_{JA})	151°C/W
LLP-16 Thermal Resistance (θ_{JA})	51°C/W
Lead Temperature (Soldering, 10 sec)	260°C
ESD Rating <i>(Note 8)</i>	1kV

Operating Range

Junction Temp. Range <i>(Note 6)</i>	0°C to +125°C
AVIN to GND	2.2V to 5.5V
PVIN to GND	2.2V to AVIN

Electrical Characteristics Specifications with standard typeface are for $T_J = 25^\circ\text{C}$ and limits in **boldface type** apply over the full **Operating Temperature Range** ($T_J = 0^\circ\text{C}$ to $+125^\circ\text{C}$). Unless otherwise specified, AVIN = PVIN = 2.5V, VDDQ = 2.5V *(Note 7)*.

Symbol	Parameter	Conditions	Min	Typ	Max	Units
V_{REF}	V_{REF} Voltage	$I_{REF_OUT} = 0\text{mA}$	1.21	1.235	1.26	V
$VOS_{V_{TT}}$	V_{TT} Output Voltage Offset	$I_{OUT} = 0\text{A}$ <i>(Note 3)</i>	-15 -20	0	15 20	mV
$\Delta V_{TT}/V_{TT}$	Load Regulation <i>(Note 4)</i>	$I_{OUT} = 0$ to 1.5A		0.5		%
		$I_{OUT} = 0$ to -1.5A		-0.5		
$Z_{V_{REF}}$	V_{REF} Output Impedance	$I_{REF} = -5\mu\text{A}$ to $+5\mu\text{A}$		5		k Ω
$Z_{V_{DDQ}}$	VDDQ Input Impedance			100		k Ω
I_q	Quiescent Current	$I_{OUT} = 0\text{A}$ <i>(Note 5)</i>		250	400	μA

Note 1: Absolute maximum ratings indicate limits beyond which damage to the device may occur. Operating range indicates conditions for which the device is intended to be functional, but does not guarantee specific performance limits. For guaranteed specifications and test conditions see Electrical Characteristics. The guaranteed specifications apply only for the test conditions listed. Some performance characteristics may degrade when the device is not operated under the listed test conditions.

Note 2: VDDQ voltage must be less than $2 \times (\text{AVIN} - 1)$ or 6V, whichever is smaller.

Note 3: V_{TT} offset is the voltage measurement defined as V_{TT} subtracted from V_{REF} .

Note 4: Load regulation is tested by using a 10ms current pulse and measuring V_{TT} .

Note 5: Quiescent current defined as the current flow into AVIN.

Note 6: At elevated temperatures, devices must be derated based on thermal resistance. The device in the SO-8 package must be derated at $\theta_{JA} = 151^\circ\text{C/W}$ junction to ambient with no heat sink. The device in the LLP-16 must be derated at $\theta_{JA} = 51^\circ\text{C/W}$ junction to ambient.

Note 7: Limits are 100% production tested at 25°C . Limits over the operating temperature range are guaranteed through correlation using Statistical Quality Control (SQC) methods. The limits are used to calculate National's Average Outgoing Quality Level (AOQL).

Note 8: The human body model is a 100pF capacitor discharged through a 1.5k Ω resistor into each pin.

Typical Performance Characteristics

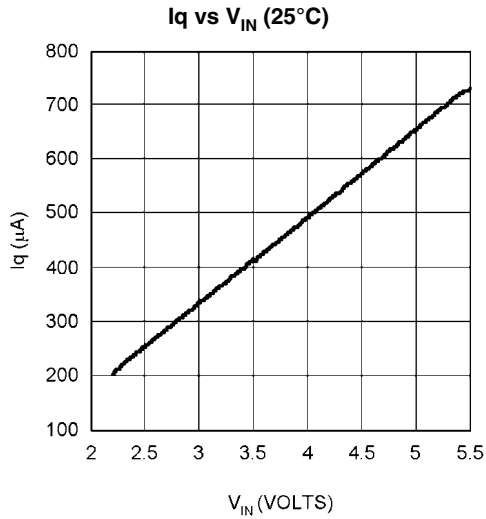

20039309

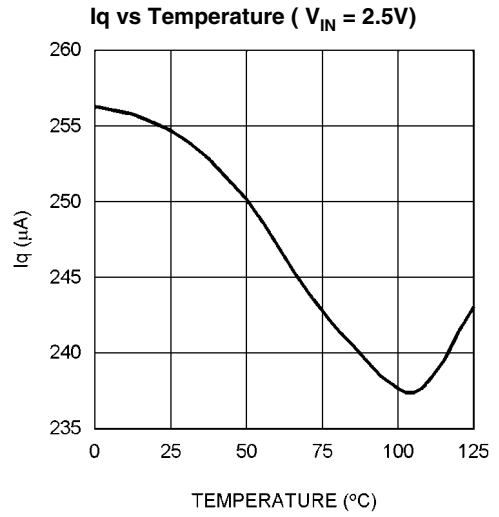

20039310

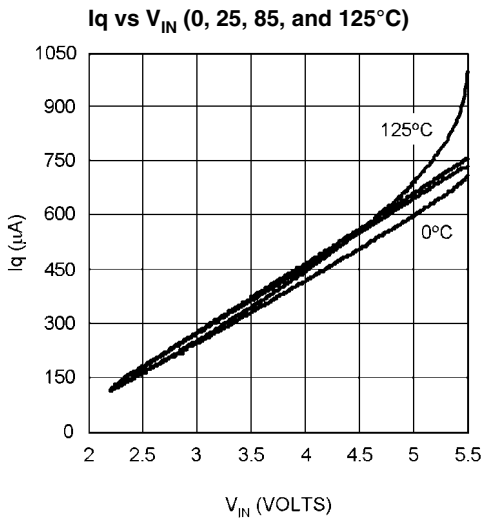

20039311

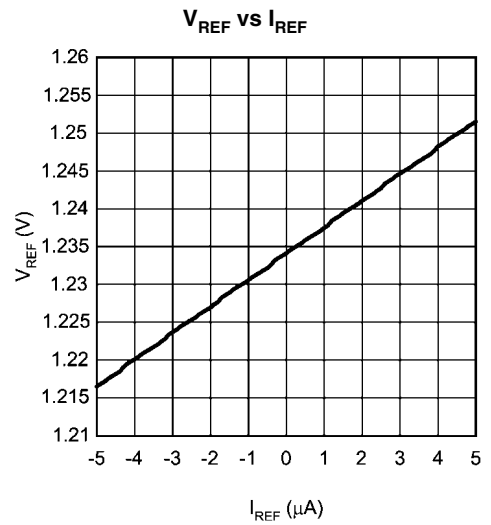

20039312

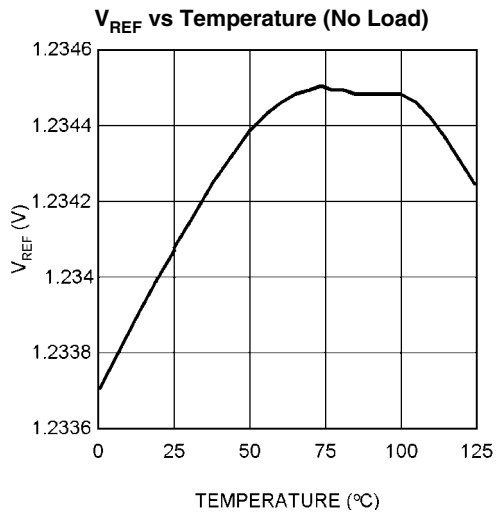

20039313

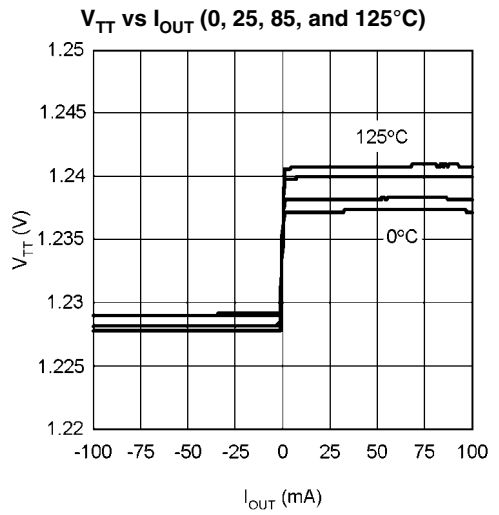

20039314

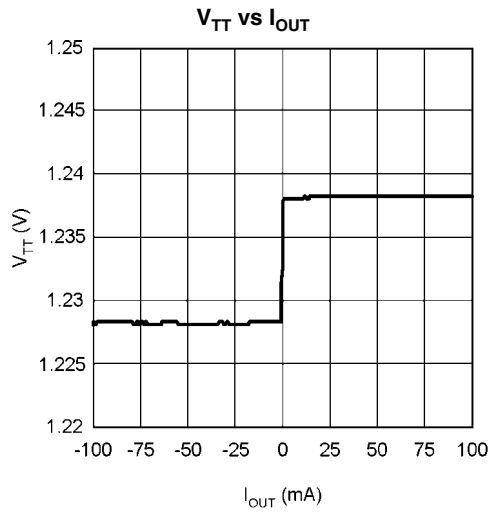

20039315

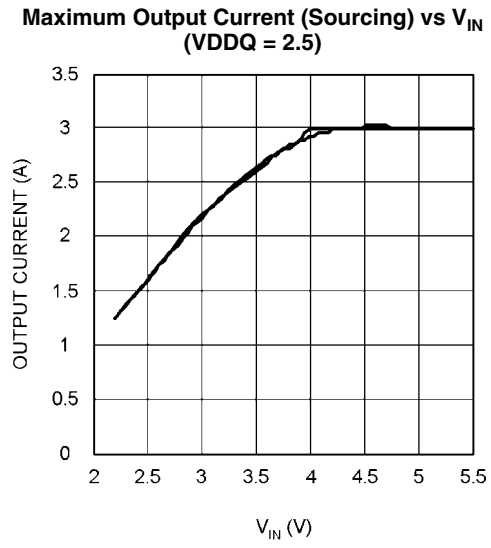

20039316

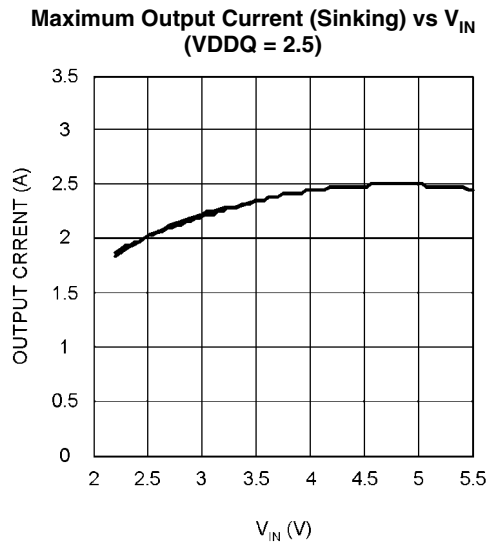

20039317

Block Diagram

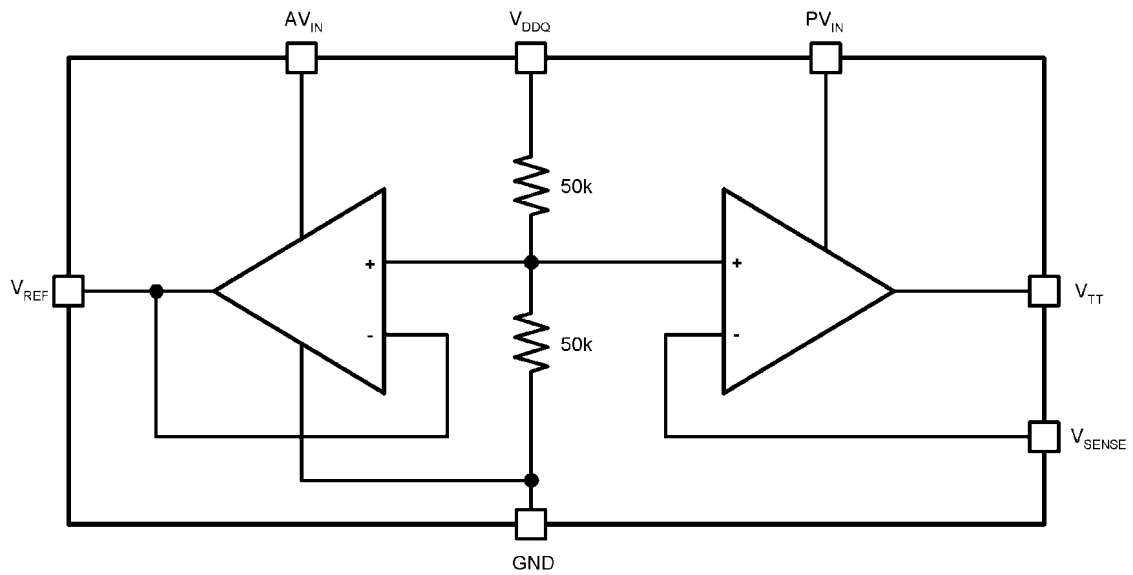

20039301

Description

The LP2995 is a linear bus termination regulator designed to meet the JEDEC requirements of SSTL-2 and SSTL-3. The LP2995 is capable of sinking and sourcing current at the output V_{TT} , regulating the voltage to equal $V_{DDQ} / 2$. A buffered reference voltage that also tracks $V_{DDQ} / 2$ is generated on the V_{REF} pin for providing a global reference to the DDR-SDRAM and Northbridge Chipset. V_{TT} is designed to track the V_{REF} voltage with a tight tolerance over the entire current range while preventing shoot through on the output stage.

Series Stub Termination Logic (SSTL) was created to improve signal integrity of the data transmission across the memory bus. This termination scheme is essential to prevent data error from signal reflections while transmitting at high frequencies encountered with DDR RAM. The most common form of termination is Class II single parallel termination. This involves using one R_S series resistor from the chipset to the memory and one R_T termination resistor. This implementation can be seen below in [Figure 1](#).

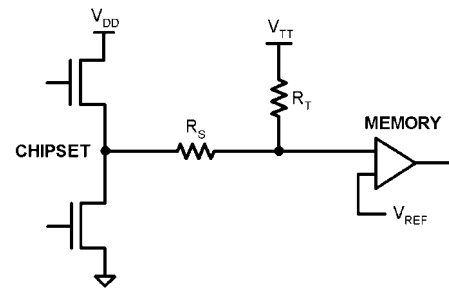

20039308

FIGURE 1.

Typical values for R_S and R_T are 25 Ohms although these can be changed to scale the current requirements from the LP2995. For determination of the current requirements of DDR-SDRAM termination please refer to the accompanying application notes.

Pin Descriptions

AVIN AND PVIN

AVIN and PVIN are the input supply pins for the LP2995. AVIN is used to supply all the internal control circuitry for the two op-amps and the output stage of V_{REF} . PVIN is used exclusively to provide the rail voltage for the output stage on the power operational amplifier used to create V_{TT} . For SSTL-2 applications AVIN and PVIN pins should be connected directly and tied to the 2.5V rail for optimal performance. This eliminates the need for bypassing the two supply pins separately.

VDDQ

VDDQ is the input that is used to create the internal reference voltage for regulating V_{TT} and V_{REF} . This voltage is generated by two internal 50k Ω resistors. This guarantees that V_{TT} and V_{REF} will track $VDDQ / 2$ precisely. The optimal implementation of VDDQ is as a remote sense for the reference input. This can be achieved by connecting VDDQ directly to the 2.5V rail at the DIMM. This ensures that the reference voltage tracks the DDR memory rails precisely without a large voltage drop from the power lines. For SSTL-2 applications VDDQ will be a 2.5V signal, which will create a 1.25V reference voltage on V_{REF} and a 1.25V termination voltage at V_{TT} . For SSTL-3 applications it may be desirable to have a different scaling factor for creating the internal reference voltage besides 0.5. For instance a typical value that is commonly used is to have the reference voltage equal $VDDQ * 0.45$. This can be achieved by placing a resistor in series with the VDDQ pin to effectively change the resistor divider.

V_{SENSE}

The purpose of the sense pin is to provide improved remote load regulation. In most motherboard applications the termination resistors will connect to V_{TT} in a long plane. If the output voltage was regulated only at the output of the LP2995, then the long trace will cause a significant IR drop, resulting in a termination voltage lower at one end of the bus than the other. The V_{SENSE} pin can be used to improve this performance, by connecting it to the middle of the bus. This will provide a better distribution across the entire termination bus.

Note: If remote load regulation is not used, then the V_{SENSE} pin must still be connected to V_{TT} .

V_{REF}

V_{REF} provides the buffered output of the internal reference voltage $VDDQ / 2$. This output should be used to provide the reference voltage for the Northbridge chipset and memory. Since these inputs are typically an extremely high impedance, there should be little current drawn from V_{REF} . For improved performance, an output bypass capacitor can be used, located close to the pin, to help with noise. A ceramic capacitor in the range of 0.1 μ F to 0.01 μ F is recommended.

V_{TT}

V_{TT} is the regulated output that is used to terminate the bus resistors. It is capable of sinking and sourcing current while regulating the output precisely to $VDDQ / 2$. The LP2995 is designed to handle peak transient currents of up to ± 3 A with a fast transient response. The maximum continuous current is a function of V_{IN} and can be viewed in the *TYPICAL PERFORMANCE CHARACTERISTICS* section. If a transient is expected to last above the maximum continuous current rating for a significant amount of time then the output capacitor should be sized large enough to prevent an excessive voltage drop. Despite the fact that the LP2995 is designed to handle

large transient output currents it is not capable of handling these for long durations, under all conditions. The reason for this is the standard packages are not able to thermally dissipate the heat as a result of the internal power loss. If large currents are required for longer durations, then care should be taken to ensure that the maximum junction temperature is not exceeded. Proper thermal derating should always be used (please refer to the Thermal Dissipation section).

Component Selection

INPUT CAPACITOR

The LP2995 does not require a capacitor for input stability, but it is recommended for improved performance during large load transients to prevent the input rail from dropping. The input capacitor should be located as close as possible to the PVIN pin. Several recommendations exist dependent on the application required. A typical value recommended for AL electrolytic capacitors is 50 μ F. Ceramic capacitors can also be used, a value in the range of 10 μ F with X5R or better would be an ideal choice. The input capacitance can be reduced if the LP2995 is placed close to the bulk capacitance from the output of the 2.5V DC-DC converter.

OUTPUT CAPACITOR

The LP2995 has been designed to be insensitive of output capacitor size or ESR (Equivalent Series Resistance). This allows the flexibility to use any capacitor desired. The choice for output capacitor will be determined solely on the application and the requirements for load transient response of V_{TT} . As a general recommendation the output capacitor should be sized above 100 μ F with a low ESR for SSTL applications with DDR-SDRAM. The value of ESR should be determined by the maximum current spikes expected and the extent at which the output voltage is allowed to droop. Several capacitor options are available on the market and a few of these are highlighted below:

AL - It should be noted that many aluminum electrolytics only specify impedance at a frequency of 120 Hz, which indicates they have poor high frequency performance. Only aluminum electrolytics that have an impedance specified at a higher frequency (between 20 kHz and 100 kHz) should be used for the LP2995. To improve the ESR several AL electrolytics can be combined in parallel for an overall reduction. An important note to be aware of is the extent at which the ESR will change over temperature. Aluminum electrolytic capacitors can have their ESR rapidly increase at cold temperatures.

Ceramic - Ceramic capacitors typically have a low capacitance, in the range of 10 to 100 μ F range, but they have excellent AC performance for bypassing noise because of very low ESR (typically less than 10 m Ω). However, some dielectric types do not have good capacitance characteristics as a function of voltage and temperature. Because of the typically low value of capacitance it is recommended to use ceramic capacitors in parallel with another capacitor such as an aluminum electrolytic. A dielectric of X5R or better is recommended for all ceramic capacitors.

Hybrid - Several hybrid capacitors such as OS-CON and SP are available from several manufacturers. These offer a large capacitance while maintaining a low ESR. These are the best solution when size and performance are critical, although their cost is typically higher than any other capacitor.

Capacitor recommendations for different application circuits can be seen in the accompanying application notes with supporting evaluation boards.

Thermal Dissipation

Since the LP2995 is a linear regulator any current flow from V_{TT} will result in internal power dissipation generating heat. To prevent damaging the part from exceeding the maximum allowable junction temperature, care should be taken to derate the part dependent on the maximum expected ambient temperature and power dissipation. The maximum allowable internal temperature rise (T_{Rmax}) can be calculated given the maximum ambient temperature (T_{Amax}) of the application and the maximum allowable junction temperature (T_{Jmax}).

$$T_{Rmax} = T_{Jmax} - T_{Amax}$$

From this equation, the maximum power dissipation (P_{Dmax}) of the part can be calculated:

$$P_{Dmax} = T_{Rmax} / \theta_{JA}$$

The θ_{JA} of the LP2995 will be dependent on several variables: the package used; the thickness of copper; the number of vias and the airflow. For instance, the θ_{JA} of the SO-8 is 163°C/W with the package mounted to a standard 8x4 2-layer board with 1oz. copper, no airflow, and 0.5W dissipation at room temperature. This value can be reduced to 151.2°C/W by changing to a 3x4 board with 2 oz. copper that is the JEDEC standard. *Figure 2* shows how the θ_{JA} varies with airflow for the two boards mentioned.

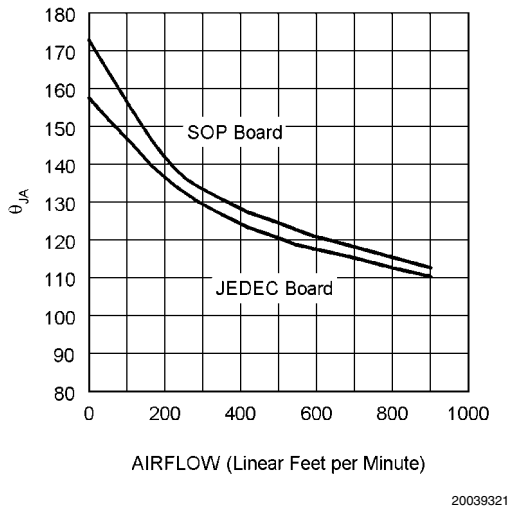

FIGURE 2. θ_{JA} vs Airflow (SO-8)

Layout is also extremely critical to maximize the output current with the LLP package. By simply placing vias under the DAP the θ_{JA} can be lowered significantly. *Figure 3* shows the LLP thermal data when placed on a 4-layer JEDEC board with copper thickness of 0.5/1/1/0.5 oz. The number of vias, with

a pitch of 1.27 mm, has been increased to the maximum of 4 where a θ_{JA} of 50.41°C/W can be obtained. Via wall thickness for this calculation is 0.036 mm for 1oz. Copper.

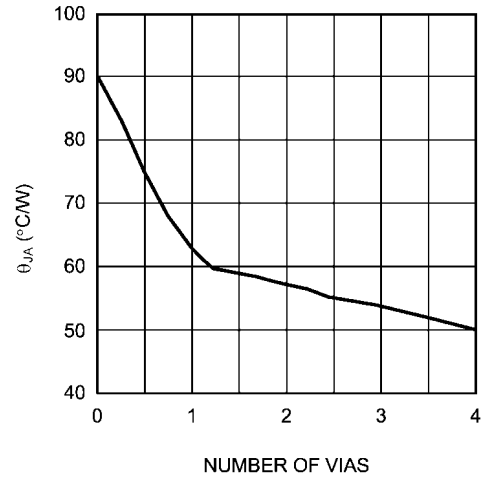

FIGURE 3. LLP-16 θ_{JA} vs # of Vias (4 Layer JEDEC Board)

Additional improvements in lowering the θ_{JA} can also be achieved with a constant airflow across the package. Maintaining the same conditions as above and utilizing the 2x2 via array, *Figure 4* shows how the θ_{JA} varies with airflow.

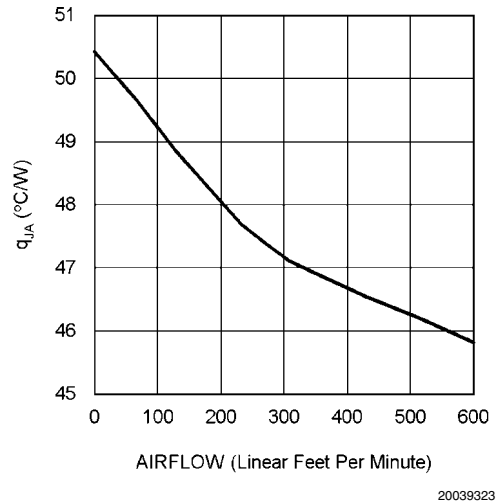

FIGURE 4. θ_{JA} vs Airflow Speed (JEDEC Board with 4 Vias)

Typical Application Circuits

The typical application circuit used for SSTL-2 termination schemes with DDR-SDRAM can be seen in [Figure 5](#).

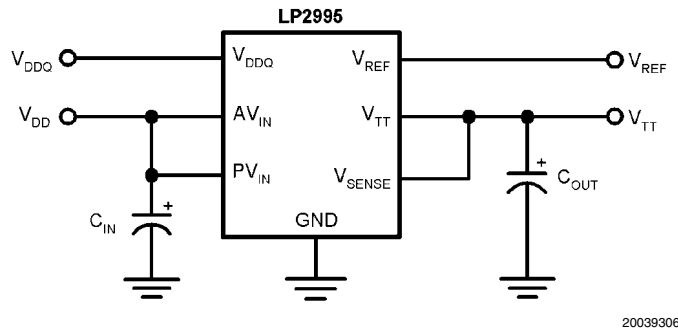

FIGURE 5. SSTL-2 Implementation

For SSTL-3 and other applications it may be desirable to change internal reference voltage scaling from $V_{DDQ} * 0.5$. An external resistor in series with the V_{DDQ} pin can be used to lower the reference voltage. Internally two $50\text{ k}\Omega$ resistors

set the output V_{TT} to be equal to $V_{DDQ} * 0.5$. The addition of a $11.1\text{ k}\Omega$ external resistor will change the internal reference voltage causing the two outputs to track $V_{DDQ} * 0.45$. An implementation of this circuit can be seen in [Figure 6](#).

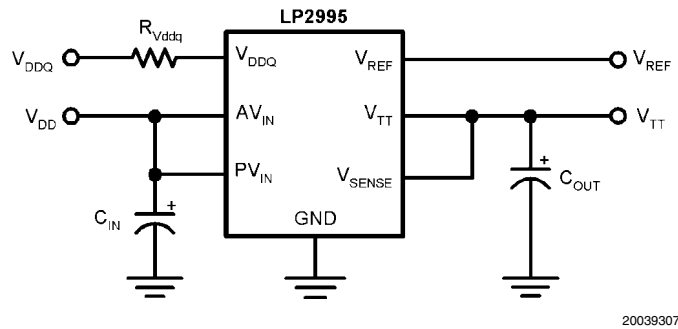

FIGURE 6. SSTL-3 Implementation

Another application that is sometimes required is to increase the V_{TT} output voltage from the scaling factor of $V_{DDQ} * 0.5$. This can be accomplished independently of V_{REF} by using a

resistor divider network between V_{TT} , V_{SENSE} and Ground. An example of this circuit can be seen in [Figure 7](#).

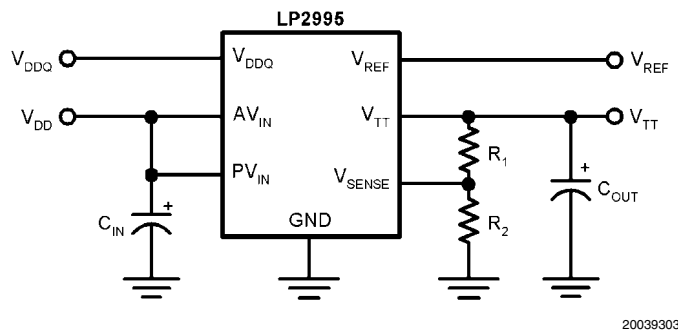
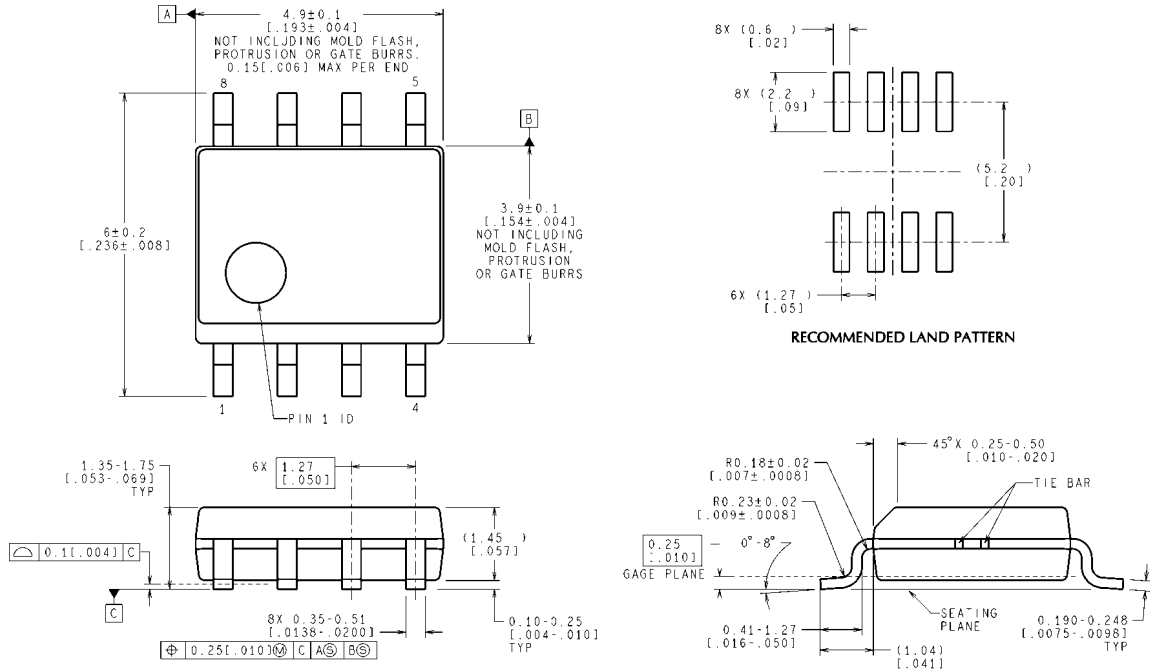

FIGURE 7.

PCB Layout Considerations

1. AVIN and PVIN should be tied together for optimal performance. A local bypass capacitor should be placed as close as possible to the PVIN pin.
2. GND should be connected to a ground plane with multiple vias for improved thermal performance.
3. V_{SENSE} should be connected to the V_{TT} termination bus at the point where regulation is required. For motherboard applications an ideal location would be at the center of the termination bus.
4. VDDQ can be connected remotely to the VDDQ rail input at either the DIMM or the Chipset. This provides the most accurate point for creating the reference voltage.
5. V_{REF} should be bypassed with a 0.01 μF or 0.1 μF ceramic capacitor for improved performance. This capacitor should be located as close as possible to the V_{REF} pin.

Physical Dimensions inches (millimeters) unless otherwise noted



CONTROLLING DIMENSION IS MILLIMETER
VALUES IN [] ARE INCHES
DIMENSIONS IN () FOR REFERENCE ONLY

**8-Lead Small Outline Package (M8)
NS Package Number M08A**

M08A (Rev M)

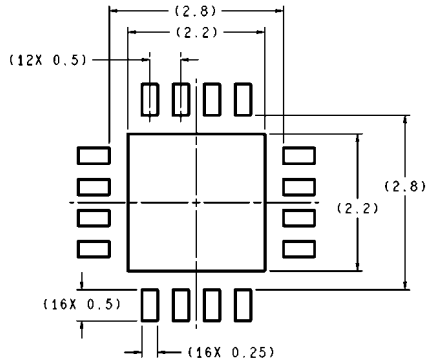

DIMENSIONS ARE IN MILLIMETERS

RECOMMENDED LAND PATTERN
1:1 RATION WITH PKG SOLDER PADS

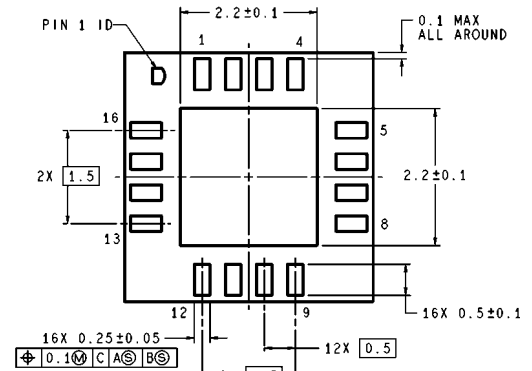
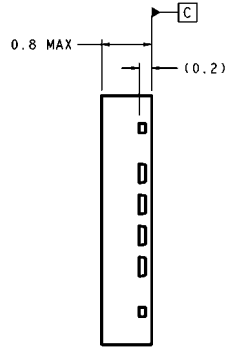
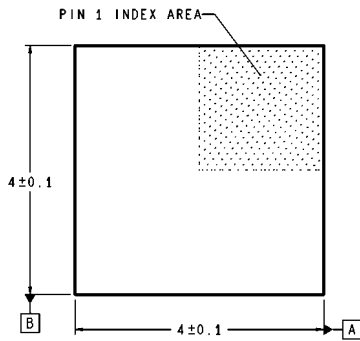

LQA16A (Rev A)

16-Lead LLP Package (LD)
NS Package Number LQA16A

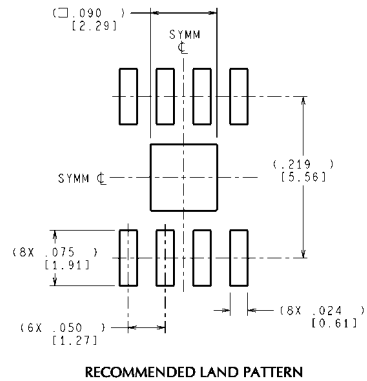
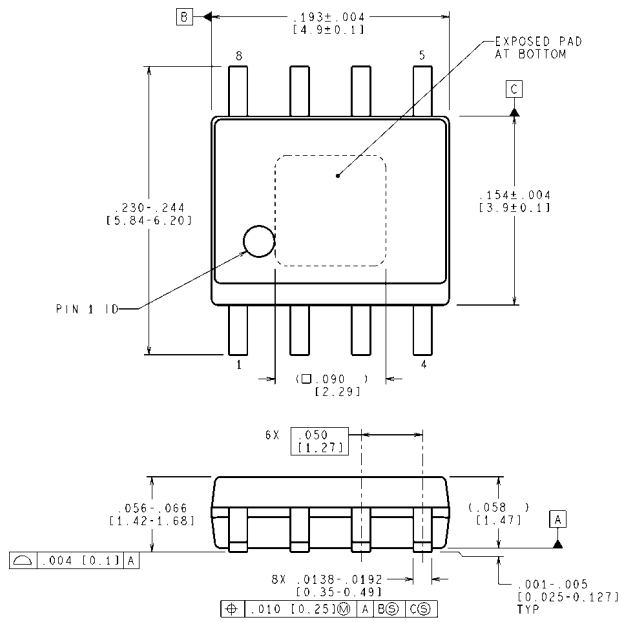

RECOMMENDED LAND PATTERN

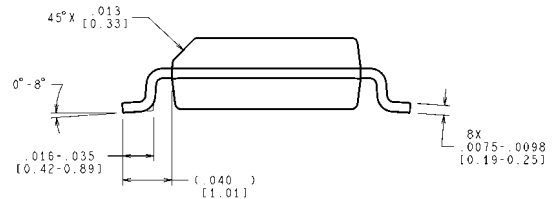

CONTROLLING DIMENSION IS INCH
VALUES IN [] ARE MILLIMETERS
DIMENSIONS IN () FOR REFERENCE ONLY

8-Lead PSOP Package (PSOP-8)
NS Package Number MRA08A

MRA08A (Rev D)

Notes

LP2995

Notes

For more National Semiconductor product information and proven design tools, visit the following Web sites at:
www.national.com

Products		Design Support	
Amplifiers	www.national.com/amplifiers	WEBENCH® Tools	www.national.com/webench
Audio	www.national.com/audio	App Notes	www.national.com/appnotes
Clock and Timing	www.national.com/timing	Reference Designs	www.national.com/refdesigns
Data Converters	www.national.com/adc	Samples	www.national.com/samples
Interface	www.national.com/interface	Eval Boards	www.national.com/evalboards
LVDS	www.national.com/lvds	Packaging	www.national.com/packaging
Power Management	www.national.com/power	Green Compliance	www.national.com/quality/green
Switching Regulators	www.national.com/switchers	Distributors	www.national.com/contacts
LDOs	www.national.com/lido	Quality and Reliability	www.national.com/quality
LED Lighting	www.national.com/led	Feedback/Support	www.national.com/feedback
Voltage References	www.national.com/vref	Design Made Easy	www.national.com/easy
PowerWise® Solutions	www.national.com/powerwise	Applications & Markets	www.national.com/solutions
Serial Digital Interface (SDI)	www.national.com/sdi	Mil/Aero	www.national.com/milaero
Temperature Sensors	www.national.com/tempensors	SolarMagic™	www.national.com/solarmagic
PLL/VCO	www.national.com/wireless	PowerWise® Design University	www.national.com/training

THE CONTENTS OF THIS DOCUMENT ARE PROVIDED IN CONNECTION WITH NATIONAL SEMICONDUCTOR CORPORATION ("NATIONAL") PRODUCTS. NATIONAL MAKES NO REPRESENTATIONS OR WARRANTIES WITH RESPECT TO THE ACCURACY OR COMPLETENESS OF THE CONTENTS OF THIS PUBLICATION AND RESERVES THE RIGHT TO MAKE CHANGES TO SPECIFICATIONS AND PRODUCT DESCRIPTIONS AT ANY TIME WITHOUT NOTICE. NO LICENSE, WHETHER EXPRESS, IMPLIED, ARISING BY ESTOPPEL OR OTHERWISE, TO ANY INTELLECTUAL PROPERTY RIGHTS IS GRANTED BY THIS DOCUMENT.

TESTING AND OTHER QUALITY CONTROLS ARE USED TO THE EXTENT NATIONAL DEEMS NECESSARY TO SUPPORT NATIONAL'S PRODUCT WARRANTY. EXCEPT WHERE MANDATED BY GOVERNMENT REQUIREMENTS, TESTING OF ALL PARAMETERS OF EACH PRODUCT IS NOT NECESSARILY PERFORMED. NATIONAL ASSUMES NO LIABILITY FOR APPLICATIONS ASSISTANCE OR BUYER PRODUCT DESIGN. BUYERS ARE RESPONSIBLE FOR THEIR PRODUCTS AND APPLICATIONS USING NATIONAL COMPONENTS. PRIOR TO USING OR DISTRIBUTING ANY PRODUCTS THAT INCLUDE NATIONAL COMPONENTS, BUYERS SHOULD PROVIDE ADEQUATE DESIGN, TESTING AND OPERATING SAFEGUARDS.

EXCEPT AS PROVIDED IN NATIONAL'S TERMS AND CONDITIONS OF SALE FOR SUCH PRODUCTS, NATIONAL ASSUMES NO LIABILITY WHATSOEVER, AND NATIONAL DISCLAIMS ANY EXPRESS OR IMPLIED WARRANTY RELATING TO THE SALE AND/OR USE OF NATIONAL PRODUCTS INCLUDING LIABILITY OR WARRANTIES RELATING TO FITNESS FOR A PARTICULAR PURPOSE, MERCHANTABILITY, OR INFRINGEMENT OF ANY PATENT, COPYRIGHT OR OTHER INTELLECTUAL PROPERTY RIGHT.

LIFE SUPPORT POLICY

NATIONAL'S PRODUCTS ARE NOT AUTHORIZED FOR USE AS CRITICAL COMPONENTS IN LIFE SUPPORT DEVICES OR SYSTEMS WITHOUT THE EXPRESS PRIOR WRITTEN APPROVAL OF THE CHIEF EXECUTIVE OFFICER AND GENERAL COUNSEL OF NATIONAL SEMICONDUCTOR CORPORATION. As used herein:

Life support devices or systems are devices which (a) are intended for surgical implant into the body, or (b) support or sustain life and whose failure to perform when properly used in accordance with instructions for use provided in the labeling can be reasonably expected to result in a significant injury to the user. A critical component is any component in a life support device or system whose failure to perform can be reasonably expected to cause the failure of the life support device or system or to affect its safety or effectiveness.

National Semiconductor and the National Semiconductor logo are registered trademarks of National Semiconductor Corporation. All other brand or product names may be trademarks or registered trademarks of their respective holders.

Copyright© 2010 National Semiconductor Corporation

For the most current product information visit us at www.national.com



National Semiconductor Americas Technical Support Center
 Email: support@nsc.com
 Tel: 1-800-272-9959

National Semiconductor Europe Technical Support Center
 Email: europe.support@nsc.com

National Semiconductor Asia Pacific Technical Support Center
 Email: ap.support@nsc.com

National Semiconductor Japan Technical Support Center
 Email: jpn.feedback@nsc.com