

ASSP

# VOLTAGE DETECTOR

## MB3761

### DESCRIPTION

Designed for voltage detector applications, the Fujitsu MB3761 is a dual comparator with a built-in high precision reference voltage generator. Outputs are open-collector outputs and enable use of the OR-connection between both channels. Both channels have hysteresis control outputs. Because of a wide power supply voltage range and a low power supply current, the MB3761 is suitable for power supply monitors and battery backup systems.

### FEATURES

- Wide power supply voltage range: 2.5 V to 40 V
- Low power and small voltage dependency supply current: 250  $\mu$ A Typ
- Built-in stable low voltage generator: 1.20 V Typ
- Easy-to-add hysteresis characteristics.
- Package:
  - 8-pin Plastic SIP Package (Suffix: -PS)
  - 8-pin Plastic DIP Package (Suffix: -P)
  - 8-pin Plastic SOP Package (Suffix: -PF)

### PACKAGE

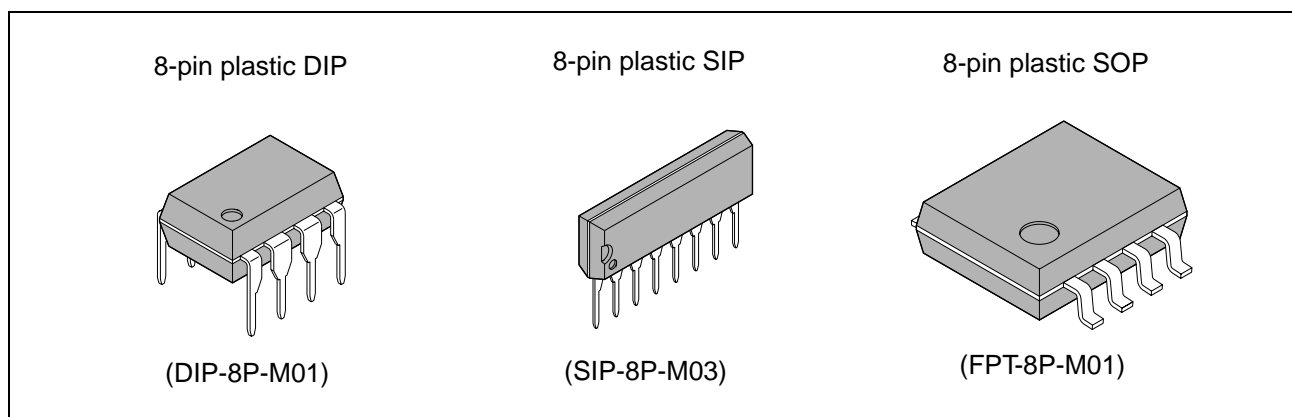

Note : This device contains circuitry to protect the inputs against damage due to high static voltages or electric fields. However, it is advised that normal precautions be taken to avoid application of any voltage higher than maximum rated voltages to this high impedance circuit.



# MB3761

## ■ PIN ASSIGNMENT

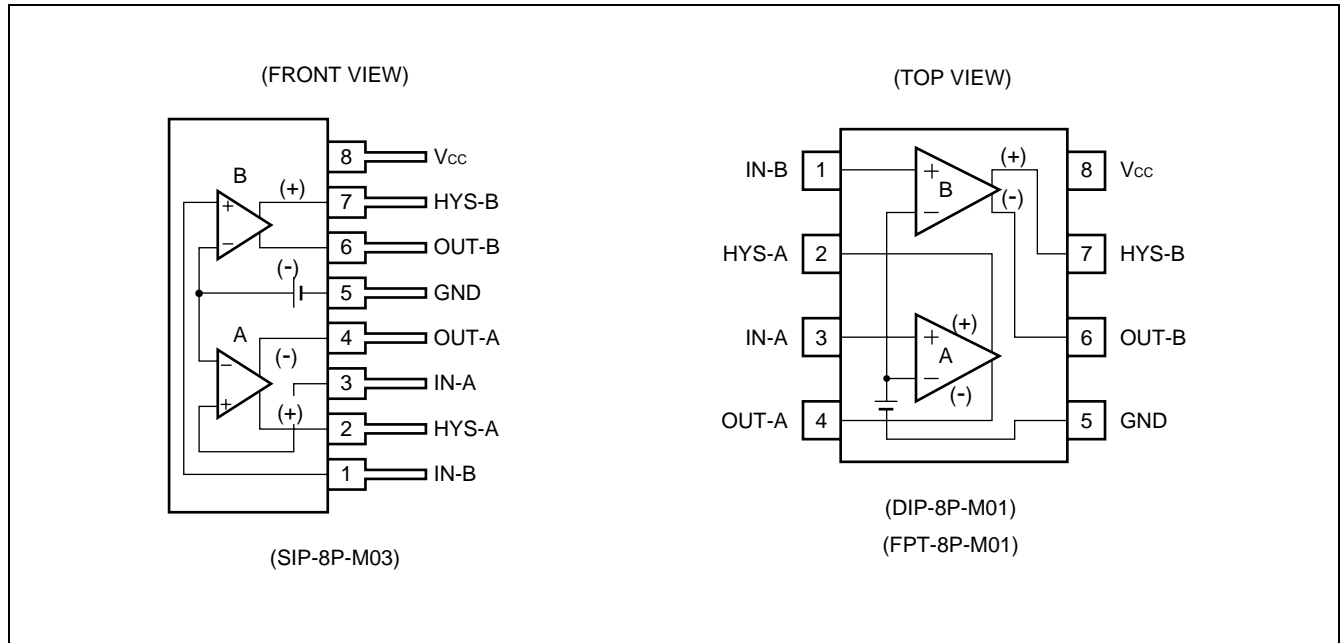

## ■ ABSOLUTE MAXIMUM RATINGS

Parameter	Symbol	Rating		Unit
		Min	Max	
Power Supply Voltage	V <sub>CC</sub>	—	41	V
Output Voltage	V <sub>O</sub>	—	41	V
Output Current	I <sub>O</sub>	—	50	mA
Input Voltage	V <sub>IN</sub>	- 0.3	+ 6.5	V
Power Dissipation	P <sub>D</sub>	—	350 (T <sub>A</sub> ≤ +70°C)	mW
Storage Temperature	T <sub>STG</sub>	- 55	+ 125	°C

WARNING: Semiconductor devices can be permanently damaged by application of stress (voltage, current, temperature, etc.) in excess of absolute maximum ratings. Do not exceed these ratings.

## ■ RECOMMENDED OPERATING CONDITIONS

Parameter	Symbol	Value		Unit
		Min	Max	
Power Supply Voltage	V <sub>CC</sub>	2.5	40	V
Operating Temperature	T <sub>A</sub>	- 20	+ 75	°C
Output Current at pin 4	I <sub>O4</sub>	—	4.5	mA
Output Current at pin 6	I <sub>O6</sub>	—	3.0	mA

WARNING: The recommended operating conditions are required in order to ensure the normal operation of the semiconductor device. All of the device's electrical characteristics are warranted when the device is operated within these ranges.

Always use semiconductor devices within their recommended operating condition ranges. Operation outside these ranges may adversely affect reliability and could result in device failure.

No warranty is made with respect to uses, operating conditions, or combinations not represented on the data sheet. Users considering application outside the listed conditions are advised to contact their FUJITSU representatives beforehand.

## ■ ELECTRICAL CHARACTERISTICS

( $T_A=+25^{\circ}\text{C}$ ,  $V_{CC}=5\text{ V}$ )

Parameter	Symbol	Conditions	Value			Unit
			Min	Typ	Max	
Power Supply Voltage	ICCL	$V_{CC}=40\text{ V}$ , $V_{IL}=1.0\text{ V}$	-	250	400	$\mu\text{A}$
	ICCH	$V_{CC}=40\text{ V}$ , $V_{IH}=1.5\text{ V}$	-	400	600	$\mu\text{A}$
Threshold Voltage	$V_{TH}$	$I_O=2\text{ mA}$ , $V_O=1\text{ V}$	1.15	1.20	1.25	V
Deviation of Threshold Voltage	$\Delta V_{TH1}$	$2.5\text{ V} \leq V_{CC} \leq 5.5\text{ V}$	-	3	12	mV
	$\Delta V_{TH2}$	$4.5\text{ V} \leq V_{CC} \leq 40\text{ V}$	-	10	40	mV
Offset Voltage between Outputs	$V_{OOSA}$	$I_{OA}=4.5\text{ mA}$ , $V_{OA}=2\text{ V}$ , $I_{HA}=20\text{ }\mu\text{A}$ , $V_{HA}=3\text{ V}$	-	2.0	-	mV
	$V_{OSSB}$	$I_{OB}=3\text{ mA}$ , $V_{OB}=2\text{ V}$ , $I_{HB}=3\text{ mA}$ , $V_{HB}=2\text{ V}$	-	2.0	-	mV
Temperature Coefficient of Threshold Voltage	$\alpha$	$-20^{\circ}\text{C} \leq T_A \leq +70^{\circ}\text{C}$	-	$\pm 0.05$	-	$\text{mV}/^{\circ}\text{C}$
Difference Voltage on Threshold Voltage between Channel	$\Delta V_{THAB}$		-10	-	-10	mV
Input Current	$I_{IL}$	$V_{IL}=1.0\text{ V}$	-	5		nA
	$I_{IH}$	$V_{IH}=1.5\text{ V}$	-	100	500	nA
Output Leakage Current	$I_{OH}$	$V_O=40\text{ V}$ , $V_{IL}=1.0\text{ V}$	-	-	1	$\mu\text{A}$
Hysteresis Output Leakage Current	$I_{HLA}$	$V_{CC}=40\text{ V}$ , $V_{HA}=0\text{ V}$ , $V_{IL}=1.0\text{ V}$	-	-	0.1	$\mu\text{A}$
	$I_{HHB}$	$V_{HB}=40\text{ V}$ , $V_{IH}=1.5\text{ V}$	-	-	1	$\mu\text{A}$
Output Sink Current	$I_{OLA}$	$V_O=1.0\text{ V}$ , $V_{IH}=1.5\text{ V}$	6	12	-	mA
	$I_{OLB}$	$V_O=1.0\text{ V}$ , $V_{IH}=1.5\text{ V}$	4	10	-	mA
Hysteresis Current	$I_{HHA}$	$V_H=0\text{ V}$ , $V_{IH}=1.5\text{ V}$	40	80	-	$\mu\text{A}$
	$I_{HLB}$	$V_H=1.0\text{ V}$ , $V_{IL}=1.0\text{ V}$	4	10	-	mA
Output Saturation Voltage	$V_{OLA}$	$I_O=4.5\text{ mA}$ , $V_{IH}=1.5\text{ V}$	-	120	400	mV
	$V_{OLB}$	$I_O=3.0\text{ mA}$ , $V_{IH}=1.5\text{ V}$	-	120	400	mV
Hysteresis Saturation	$V_{HHA}$	$I_H=20\text{ }\mu\text{A}$ , $V_{IH}=1.5\text{ V}$	-	50	200	mV
	$V_{HLB}$	$I_H=3.0\text{ mA}$ , $V_{IL}=1.0\text{ V}$	-	120	400	mV
Output Delay Time	$t_{PHL}$	$R_L=5\text{ k}\Omega$	-	2	-	$\mu\text{s}$
	$t_{PLH}$	$R_L=5\text{ k}\Omega$	-	3	-	$\mu\text{s}$

## EQUIVALENT CIRCUIT

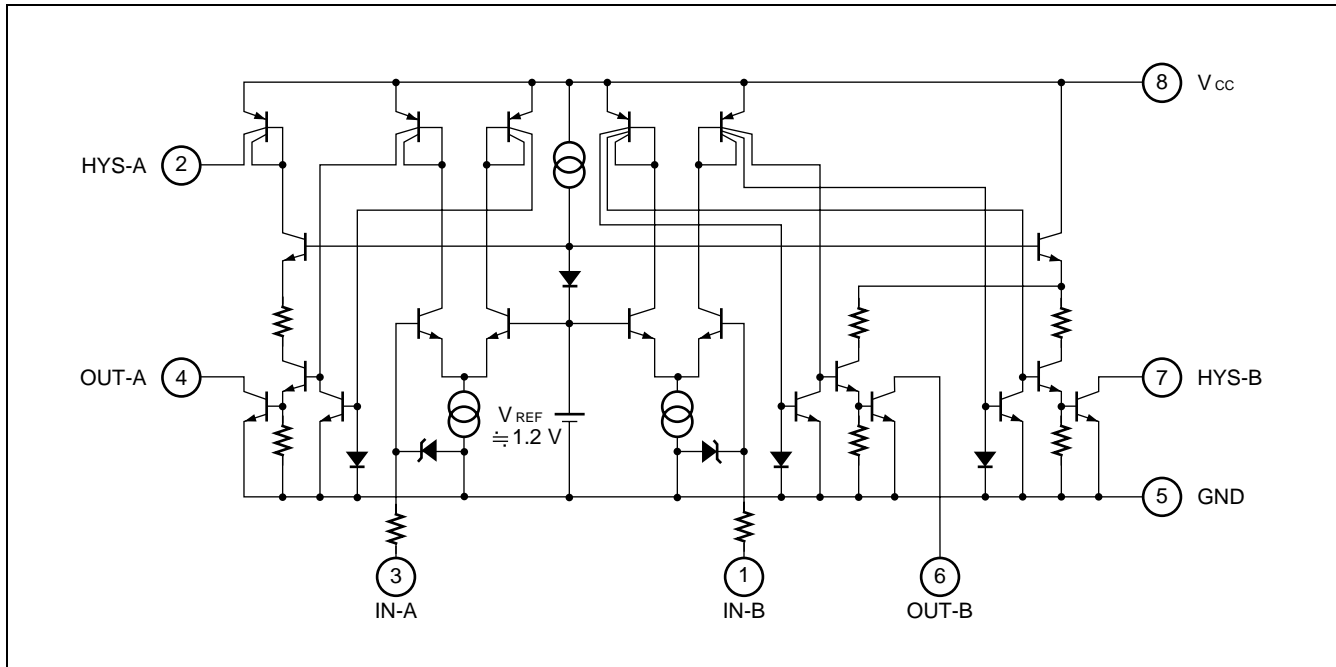

## OPERATIONAL DEFINITIONS

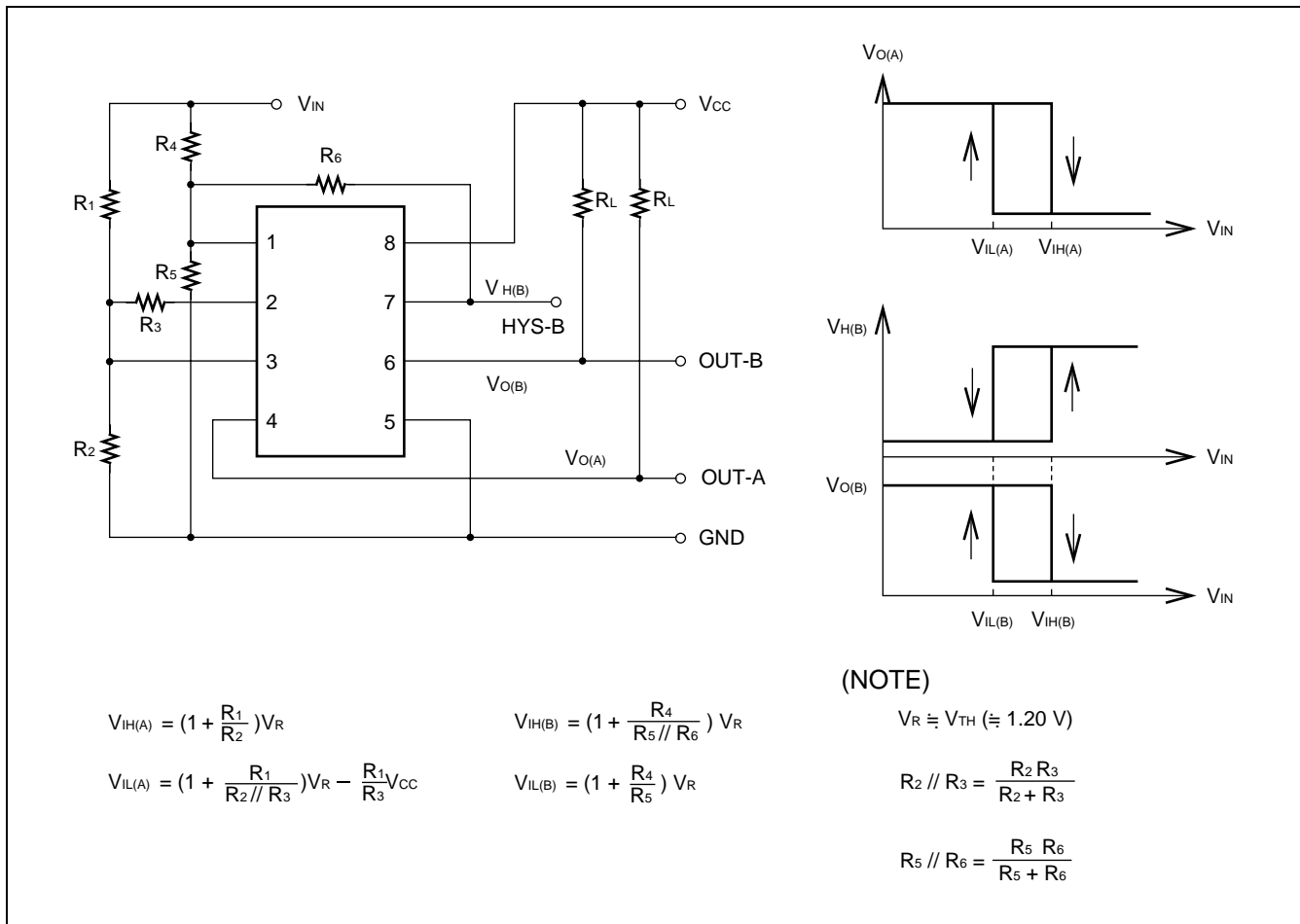

## TYPICAL PERFORMANCE CHARACTERISTICS

Power Supply Current vs. Power Supply Voltage

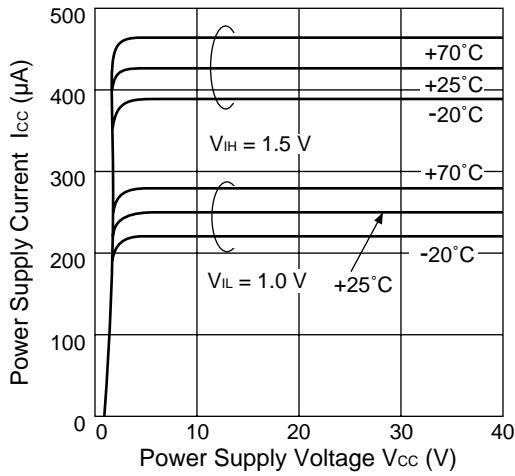

Hysteresis (A) Current vs. Power Supply Voltage

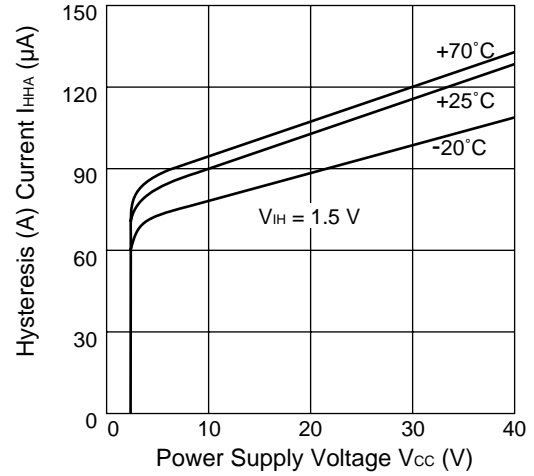

Output (A) Voltage vs. Output (A) Current

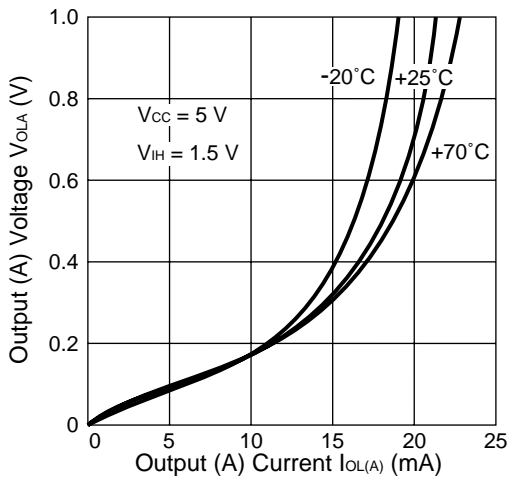

Output (B) Voltage vs. Output (B) Current

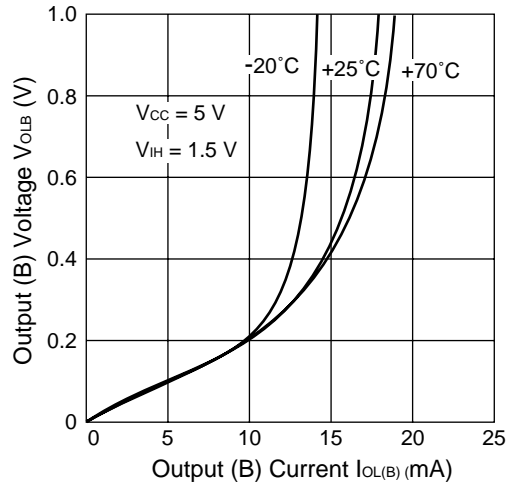

Threshold Voltage vs. Power Supply Voltage

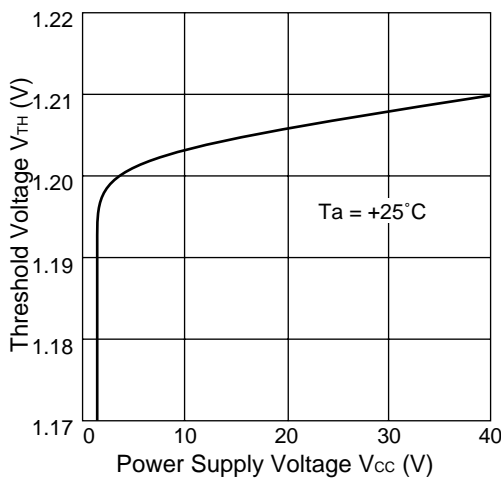

Threshold Voltage vs. Temperature

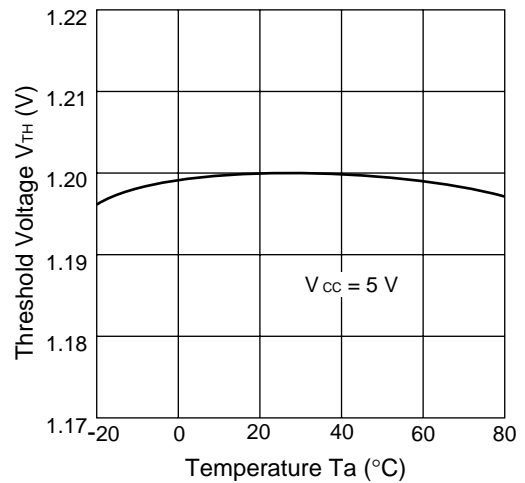

## APPLICATION EXAMPLES

### 1. Addition of Hysteresis

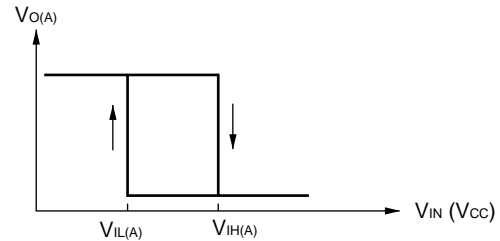
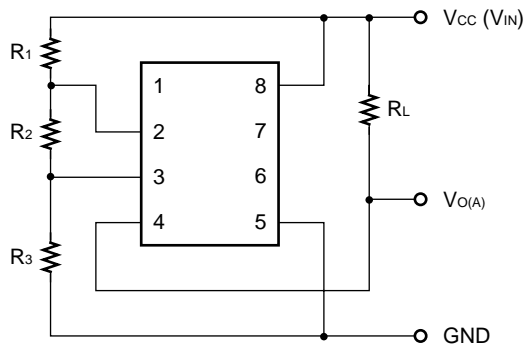

$$V_{IH(A)} \cong \left(1 + \frac{R_1 + R_2}{R_3}\right) V_R$$

$$V_{IL(A)} \cong \left(1 + \frac{R_2}{R_3}\right) V_R$$

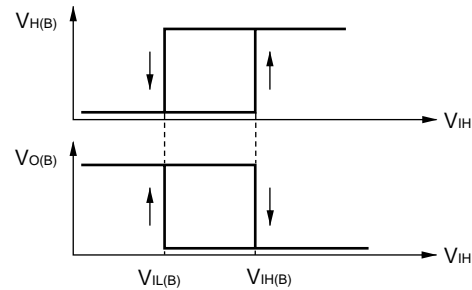
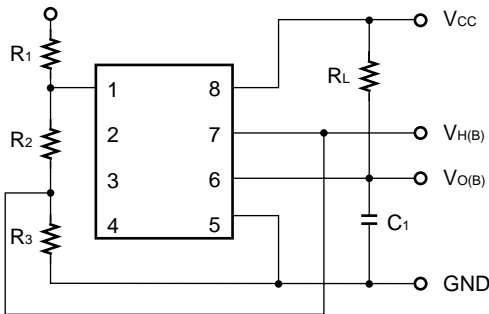

$$V_{IH(B)} \cong \left(1 + \frac{R_1}{R_2}\right) V_R$$

$$V_{IL(B)} \cong \left(1 + \frac{R_1}{R_2 + R_3}\right) V_R$$

Note : All calculations occur with the output voltage at 0. The hysteresis values are adjusted for load condition and saturation voltage.

### 2. Voltage Detection for Alarm

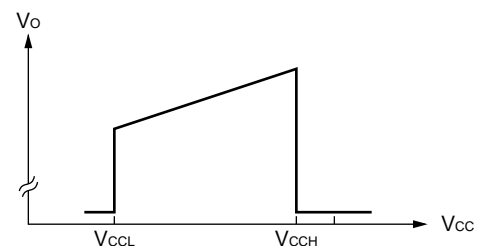
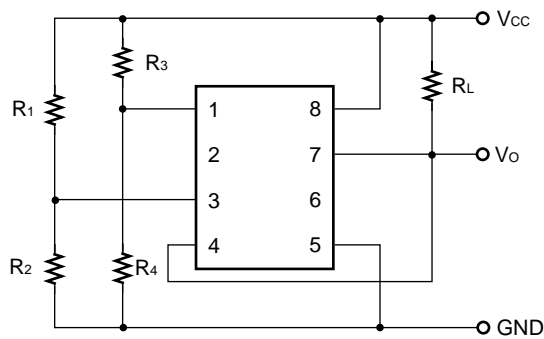

$$V_{CCCH} = \left(1 + \frac{R_1}{R_2}\right) V_R$$

$$V_{CCCL} = \left(1 + \frac{R_3}{R_4}\right) V_R$$

$$V_{CCCL} \geq 2.5 \text{ V}$$

For hysteresis, a positive feedback from pin 2 or 7 is required.

### 3. Voltage Detection for Alarm

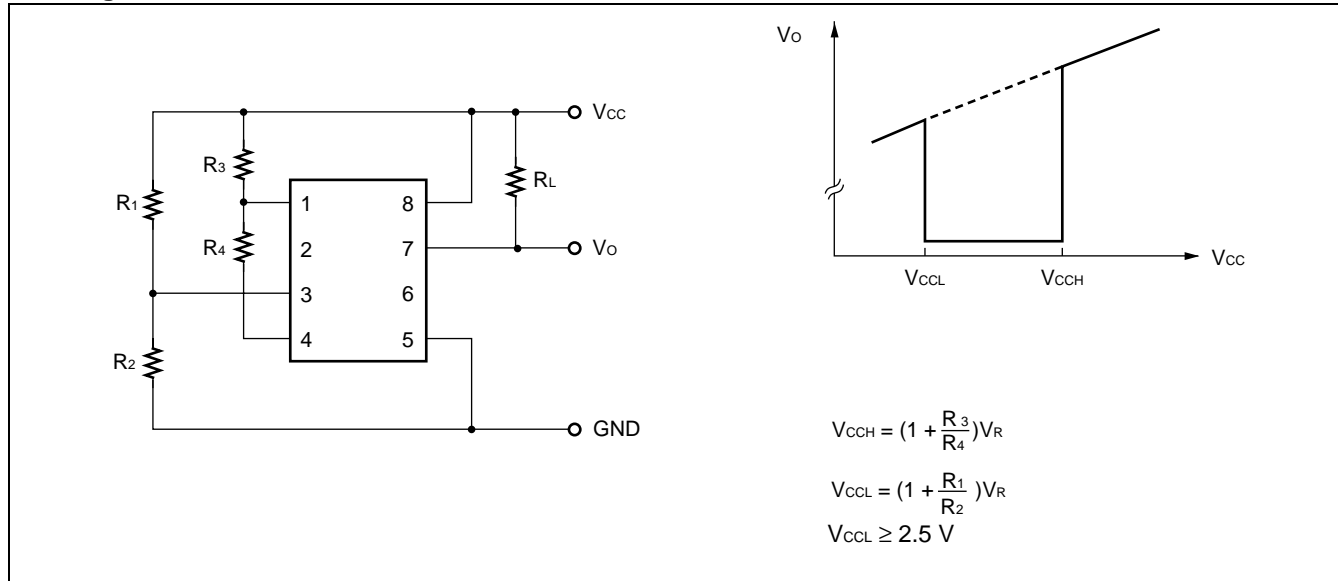

### 4. Programmable Zener

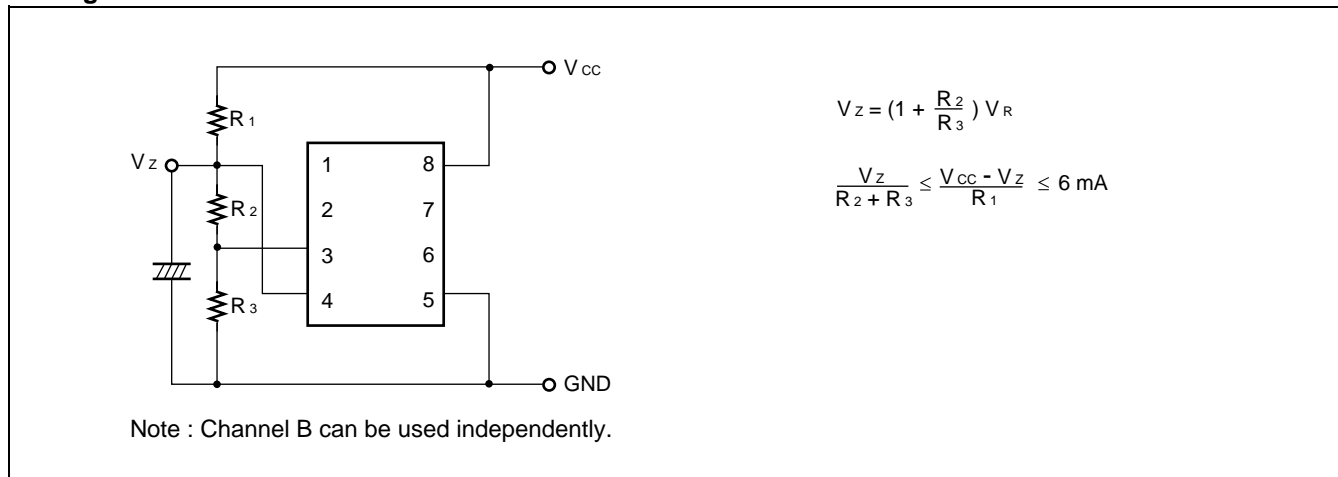



## 5. Recovery Reset Circuit

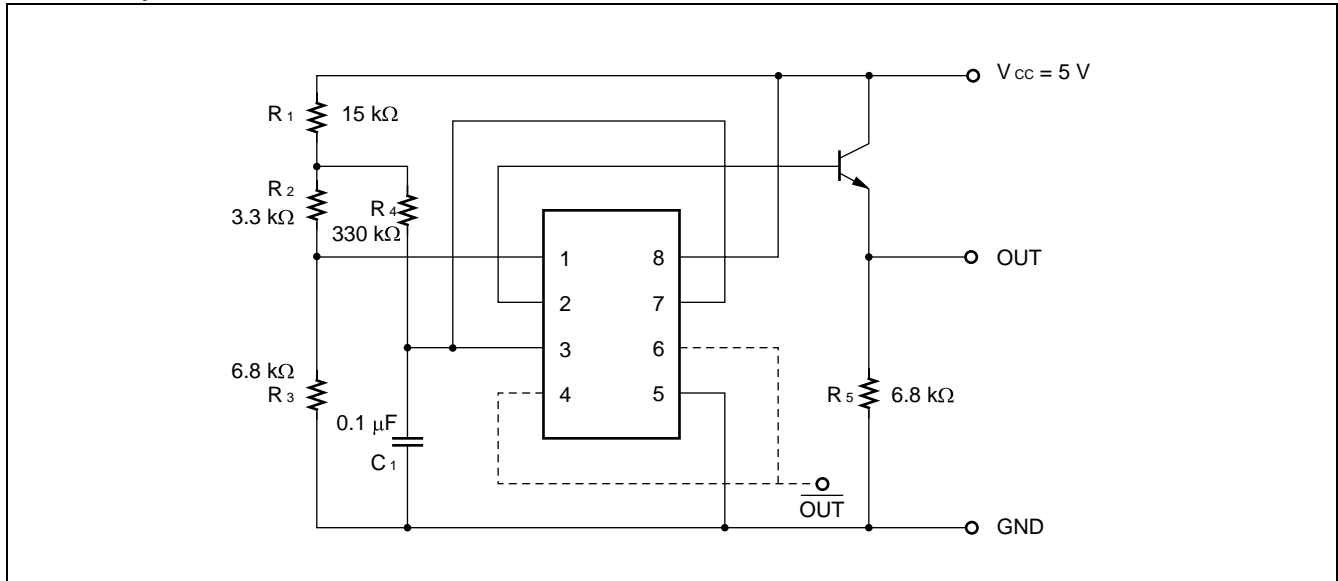

## ■ TYPICAL CHARACTERISTICS

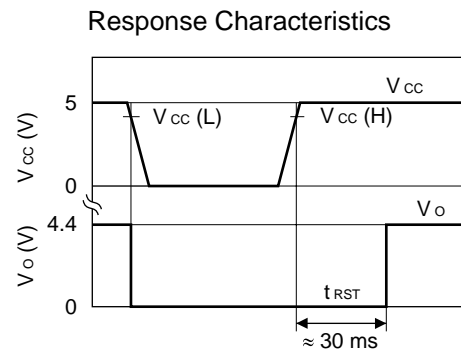
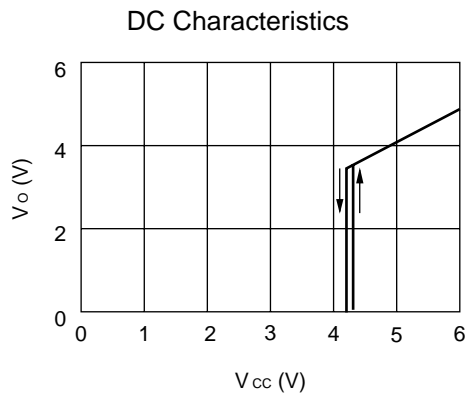

- Voltage Threshold Levels ( $V_{CC(L)}$  and  $V_{CC(H)}$ ) and Hysteresis Width can be changed by the resistors ( $R_1$  through  $R_4$ ).

$$V_{CC(L)} = \frac{R_1 + R_2 + R_3}{R_3} V_{TH}$$

$$V_{CC(H)} = V_{CC(L)} + \frac{R_1 (R_2 + R_3)}{R_3 R_4} V_{TH}$$

- Power-On Reset Time is provided by the following approximate equation:

$$t_{RST} = -C_1 R_4 \cdot \ln \left\{ 1 - \frac{V_{TH}}{V_{CC}} \left( 1 + \frac{R_1}{R_2 + R_3} \right) \right\}$$

- The recommended value of  $h_{FE}$  of the external transistor is from 50 to 200.
- In the case of an instant power fail, the remaining charge in  $C_1$  effects  $t_{RST}$ .
- If necessary, the reversed output is provided on HYS terminal

## ■ NOTES ON USE

- Take account of common impedance when designing the earth line on a printed wiring board.
- Take measures against static electricity.
  - For semiconductors, use antistatic or conductive containers.
  - When storing or carrying a printed circuit board after chip mounting, put it in a conductive bag or container.
  - The work table, tools and measuring instruments must be grounded.
  - The worker must put on a grounding device containing 250 kΩ to 1 MΩ resistors in series.
- Do not apply a negative voltage
  - Applying a negative voltage of -0.3 V or less to an LSI may generate a parasitic transistor, resulting in malfunction.

## ■ ORDERING INFORMATION

Part number	Package	Remarks
MB3761M	8-pin Plastic DIP (DIP-8P-M01)	
MB3761PS	8-pin Plastic SIP (SIP-8P-M03)	
MB3761PF	8-pin Plastic SOP (FPT-8P-M01)	

# MB3761

## ■ PACKAGE DIMENSION

8-pin Plastic DIP  
(DIP-8P-M01)

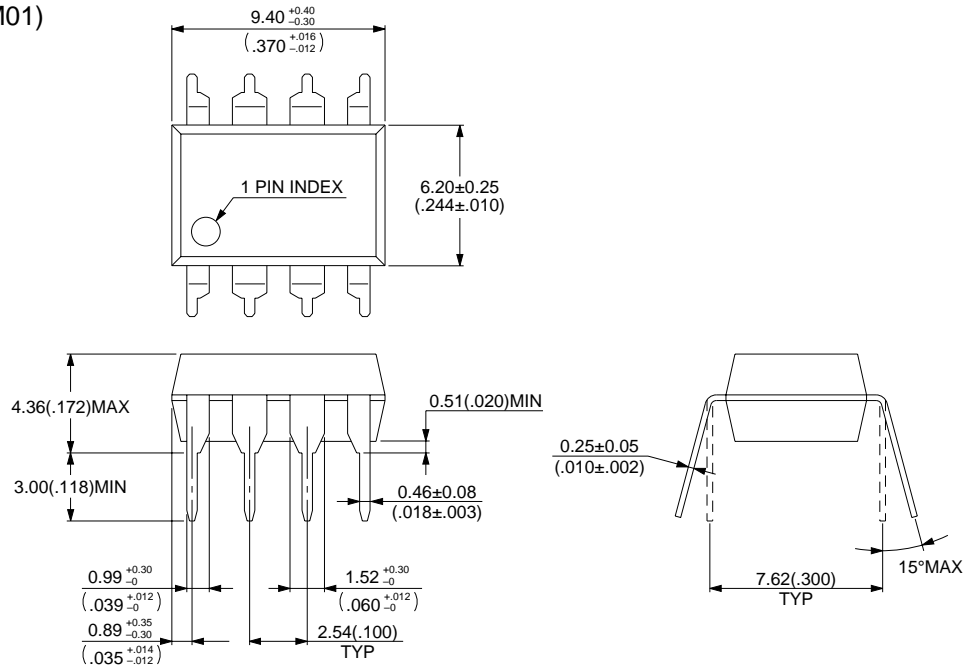

© 1994 FUJITSU LIMITED D08006S-2C-3

Dimensions in mm (inches) .

Note : The values in parentheses are reference values.

(Continued)

## 8-pin Plastic SIP (SIP-8P-M03)

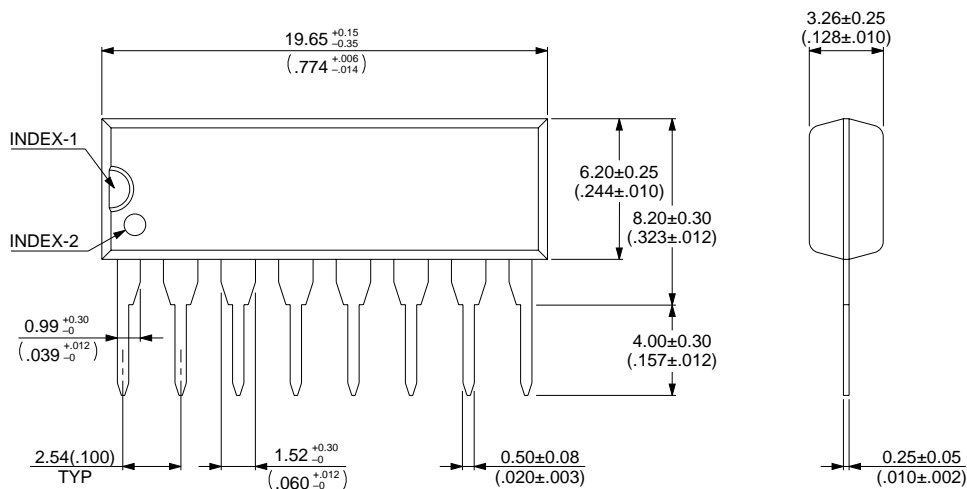

© 1994 FUJITSU LIMITED S08010S-3C-2

Dimensions in mm (inches) .

Note : The values in parentheses are reference values.

(Continued)

# MB3761

## 8-pin Plastic SOP (FPT-8P-M01)

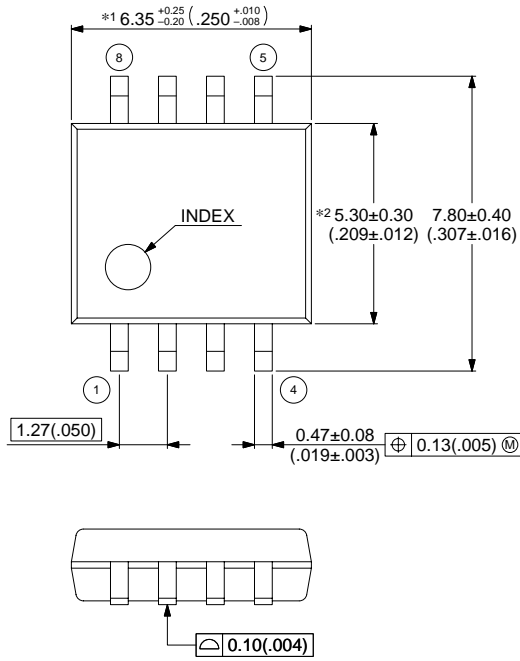

- Note 1) \*1 : These dimensions include resin protrusion.  
 Note 2) \*2 : These dimensions do not include resin protrusion.  
 Note 3) Pins width and pins thickness include plating thickness.  
 Note 4) Pins width do not include tie bar cutting remainder.

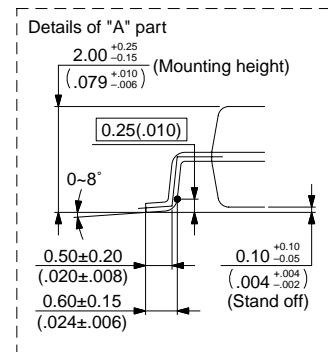
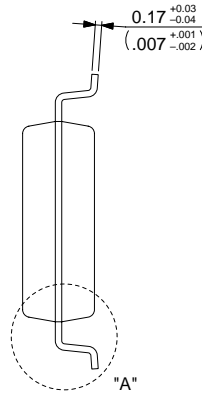

Dimensions in mm (inches) .  
 Note : The values in parentheses are reference values

## FUJITSU LIMITED

All Rights Reserved.

The contents of this document are subject to change without notice. Customers are advised to consult with FUJITSU sales representatives before ordering.

The information, such as descriptions of function and application circuit examples, in this document are presented solely for the purpose of reference to show examples of operations and uses of Fujitsu semiconductor device; Fujitsu does not warrant proper operation of the device with respect to use based on such information. When you develop equipment incorporating the device based on such information, you must assume any responsibility arising out of such use of the information. Fujitsu assumes no liability for any damages whatsoever arising out of the use of the information.

Any information in this document, including descriptions of function and schematic diagrams, shall not be construed as license of the use or exercise of any intellectual property right, such as patent right or copyright, or any other right of Fujitsu or any third party or does Fujitsu warrant non-infringement of any third-party's intellectual property right or other right by using such information. Fujitsu assumes no liability for any infringement of the intellectual property rights or other rights of third parties which would result from the use of information contained herein.

The products described in this document are designed, developed and manufactured as contemplated for general use, including without limitation, ordinary industrial use, general office use, personal use, and household use, but are not designed, developed and manufactured as contemplated (1) for use accompanying fatal risks or dangers that, unless extremely high safety is secured, could have a serious effect to the public, and could lead directly to death, personal injury, severe physical damage or other loss (i.e., nuclear reaction control in nuclear facility, aircraft flight control, air traffic control, mass transport control, medical life support system, missile launch control in weapon system), or (2) for use requiring extremely high reliability (i.e., submersible repeater and artificial satellite).

Please note that Fujitsu will not be liable against you and/or any third party for any claims or damages arising in connection with above-mentioned uses of the products.

Any semiconductor devices have an inherent chance of failure. You must protect against injury, damage or loss from such failures by incorporating safety design measures into your facility and equipment such as redundancy, fire protection, and prevention of over-current levels and other abnormal operating conditions.

If any products described in this document represent goods or technologies subject to certain restrictions on export under the Foreign Exchange and Foreign Trade Law of Japan, the prior authorization by Japanese government will be required for export of those products from Japan.

F0308

© FUJITSU LIMITED Printed in Japan