

3.3 V 16 K/32 K × 36 FLEX36™ Synchronous Dual-Port Static RAM

Features

- True dual-ported memory cells which allow simultaneous access of the same memory location
- Two Flow-Through/Pipelined devices
 - 16K × 36 organization (CY7C09569V)
 - 32K × 36 organization (CY7C09579V)
- 0.25-micron CMOS for optimum speed/power
- Three modes
 - Flow-Through
 - Pipelined
 - Burst
- Bus-Matching Capabilities on Right Port (×36 to ×18 or ×9)
- Byte-Select Capabilities on Left Port
- 100-MHz Pipelined Operation
- High-speed clock to data access 5/6/8 ns
- 3.3 V Low operating power
 - Active = 250 mA (typical)
 - Standby = 10 μA (typical)
- Fully synchronous interface for ease of use
- Burst counters increment addresses internally
 - Shorten cycle times
 - Minimize bus noise
 - Supported in Flow-Through and Pipelined modes
- Counter Address Read Back via I/O lines
- Single Chip Enable
- Automatic power-down
- Commercial and Industrial Temperature Ranges
- Compact package
 - 144-pin TQFP (20 × 20 × 1.4 mm)
 - 144-pin Pb-free TQFP (20 × 20 × 1.4 mm)
 - 172-ball BGA (1.0-mm pitch) (15 × 15 × 0.51 mm)

Logic Block Diagram

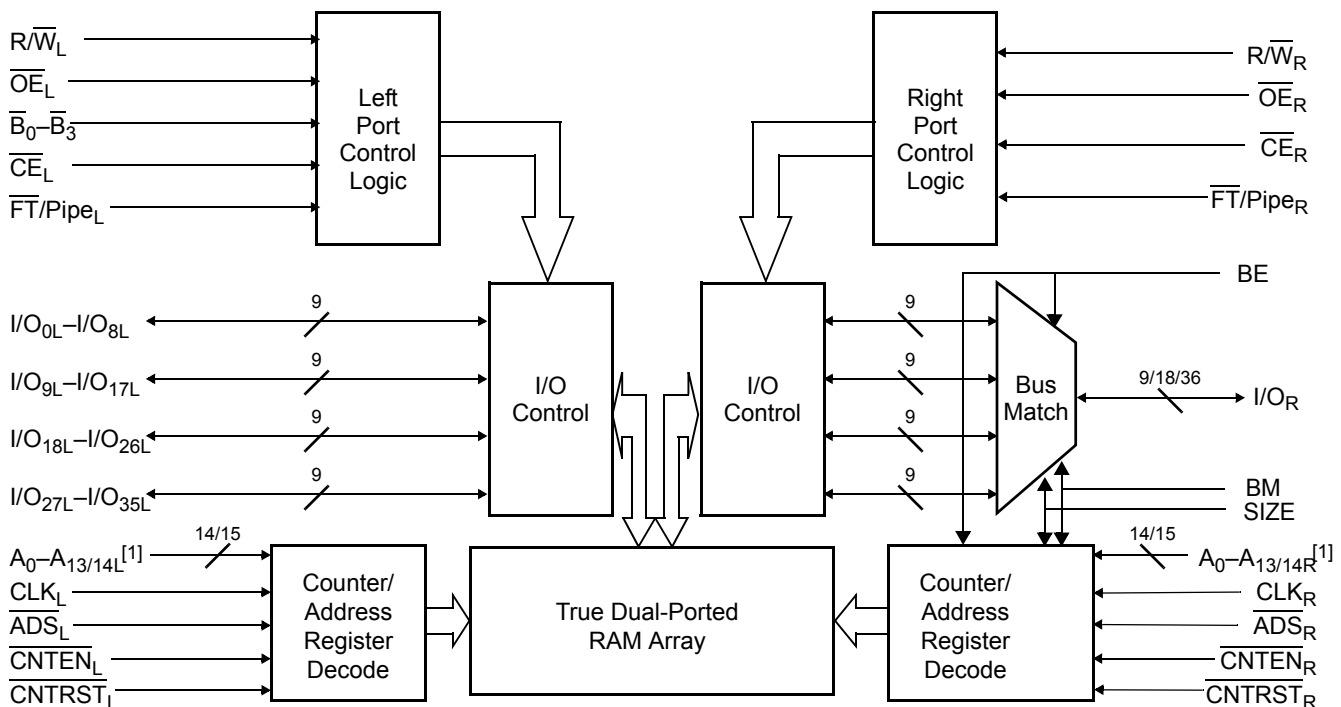

Note

1. A₀-A₁₃ for 16K; A₀-A₁₄ for 32K devices.

Functional Description

The CY7C09569V and CY7C09579V are high-speed 3.3 V synchronous CMOS 16K and 32K × 36 dual-port static RAMs. Two ports are provided, permitting independent, simultaneous access for reads and writes to any location in memory. Registers on control, address, and data lines allow for minimal set-up and hold times. In pipelined output mode, data is registered for decreased cycle time. Clock to data valid $t_{CD2} = 5$ ns (pipelined). Flow-through mode can also be used to bypass the pipelined output register to eliminate access latency. In flow-through mode data will be available $t_{CD1} = 12.5$ ns after the address is clocked into the device. Pipelined output or flow-through mode is selected via the FT/Pipe pin.

Each port contains a burst counter on the input address register. The internal write pulse width is independent of the external R/W LOW duration. The internal write pulse is self-timed to allow the shortest possible cycle times.

A HIGH on \overline{CE} for one clock cycle will power down the internal circuitry to reduce the static power consumption. In the pipelined mode, one cycle is required with \overline{CE} LOW to reactivate the outputs.

Counter Enable Inputs are provided to stall the operation of the address input and utilize the internal address generated by the internal counter for fast interleaved memory applications. A port's burst counter is loaded with the port's Address Strobe (ADS). When the port's Count Enable (CNTEN) is asserted, the address counter will increment on each LOW-to-HIGH transition of that port's clock signal. This will read/write one word from/into each successive address location until CNTEN is deasserted. The counter can address the entire memory array and will loop back to the start. Counter Reset (CNTRST) is used to reset the burst counter.

All parts are available in 144-pin Thin Quad Plastic Flatpack (TQFP), 144-pin Pb-free Thin Quad Plastic Flatpack (TQFP) and 172-ball Ball Grid Array (BGA) packages.

Contents

Pin Configurations	4	Pipelined Read with Address Counter Advance	19
Selection Guide	6	Flow-Through Read with	
Pin Definitions	6	Address Counter Advance	19
Maximum Ratings	7	Write with Address Counter Advance	
Operating Range	7	(Flow-Through or Pipelined Outputs)	20
Electrical Characteristics	7	Counter Reset (Pipelined Outputs)	21
Capacitance	7	Counter Reset (Flow-Through Outputs)	22
AC Test Load and Waveforms	8	Pipelined Read of State of Address Counter	23
Switching Characteristics	9	Flow-Through Read of State of	
Switching Waveforms	11	Address Counter	23
Read Cycle for		Read/Write and Enable Operation	24
Flow-Through Output (FT/PIPE = VIL)	11	Address Counter Control Operation	24
Read Cycle for		Right Port Configuration	25
Pipelined Operation (FT/PIPE = VIH)	11	Right Port Operation	25
Bus Match Read Cycle for		Readout of Internal Address Counter	25
Flow-Through Output (FT/PIPE = VIL)	12	Left Port Operation	25
Bus Match Read Cycle		Counter Operation	26
for Pipelined Operation (FT/PIPE = VIH)	12	Bus Match Operation	26
Bank Select Pipelined Read	13	Long-Word (36-bit) Operation	26
Left Port Write to		Word (18-bit) Operation	27
Flow-Through Right Port Read	13	Byte (9-bit) Operation	27
Pipelined Read-to-Write-to-Read (OE = VIL)	14	Ordering Information	28
Pipelined Read-to-Write-to-Read		16K × 36 3.3 V Synchronous Dual-Port SRAM	28
(OE Controlled)	15	32K × 36 3.3 V Synchronous Dual-Port SRAM	28
Bus Match Pipelined Read-to-Write-to-Read		Ordering Code Definitions	28
(OE = VIL)	16	Package Diagrams	29
Flow-Through Read-to-Write-to-Read		Sales, Solutions, and Legal Information	32
(OE = VIL)	17	Worldwide Sales and Design Support	32
Flow-Through Read-to-Write-to-Read		Products	32
(OE Controlled)	17	PSoC Solutions	32
Bus Match Flow-Through Read-to-Write-to-Read			
(OE = VIL)	18		

Pin Configurations

144-pin Thin Quad Flatpack (TQFP) Top View

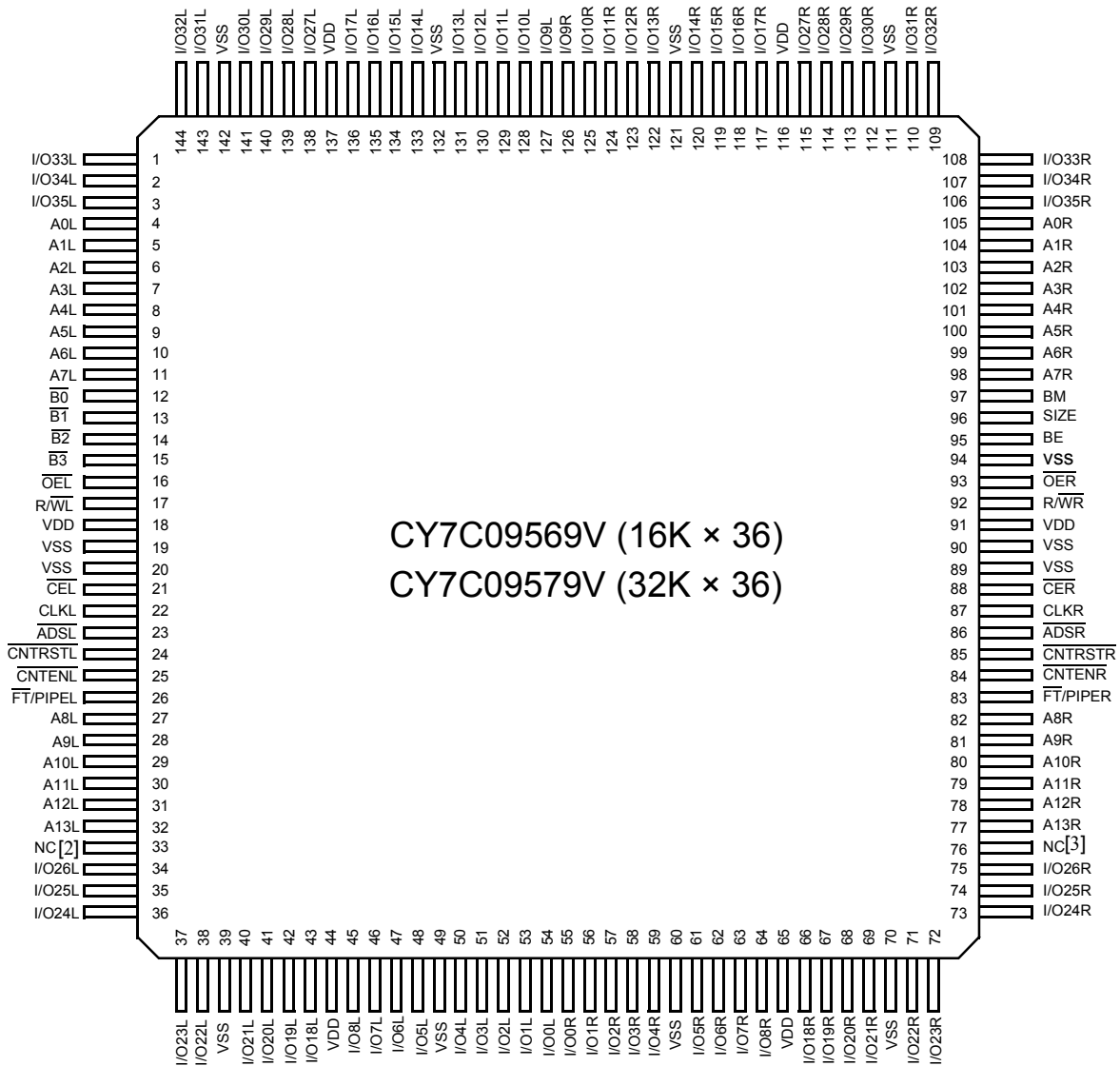

Notes

2. This pin is A14L for CY7C09579V.
3. This pin is A14R for CY7C09579V.

172-ball Ball Grid Array (BGA)

Top View

	1	2	3	4	5	6	7	8	9	10	11	12	13	14
A	I/O32L	I/O30L	NC	VSS	I/O13L	VDD	I/O11L	I/O11R	VDD	I/O13R	VSS	NC	I/O30R	I/O32R
B	A0L	I/O33L	I/O29	I/O17L	I/O14L	I/O12L	I/O9L	I/O9R	I/O12R	I/O14R	I/O17R	I/O29R	I/O33R	A0R
C	NC	A1L	I/O31L	I/O27L	NC	I/O15L	I/O10L	I/O10R	I/O15R	NC	I/O27R	I/O31R	A1R	NC
D	A2L	A3L	I/O35L	I/O34L	I/O28L	I/O16L	VSS	VSS	I/O16R	I/O28R	I/O34R	I/O35R	A3R	A2R
E	A4L	A5L	NC	$\overline{B0L}$	NC	NC			NC	NC	BM	NC	A5R	A4R
F	VDD	A6L	A7L	$\overline{B1L}$	NC					NC	SIZE	A7R	A6R	VDD
G	\overline{OEL}	$\overline{B2L}$	$\overline{B3L}$	\overline{CEL}							\overline{CER}	VSS	BE	\overline{OER}
H	VSS	$\overline{R/WL}$	A8L	CLKL							CLKR	A8R	$\overline{R/WR}$	VSS
J	A9L	A10L	VSS	\overline{ADSL}	NC					NC	\overline{ADSR}	VSS	A10R	A9R
K	A11L	A12L	NC	\overline{CNRSTL}	NC	NC			NC	NC	\overline{CNRSTR}	NC	A12R	A11R
L	$\overline{FT/PIPEL}$	A13L	\overline{CNTENL}	I/O26L	I/O25L	I/O19L	VSS	VSS	I/O19R	I/O25R	I/O26R	\overline{CNTENR}	A13R	$\overline{FT/PIPER}$
M	NC	NC ^[2]	I/O22L	I/O18L	NC	I/O7L	I/O2L	I/O2R	I/O7R	NC	I/O18R	I/O22R	NC ^[3]	NC
N	I/O24L	I/O20L	I/O8L	I/O6L	I/O5L	I/O3L	I/O0L	I/O0R	I/O3R	I/O5R	I/O6R	I/O8R	I/O20R	I/O24R
P	I/O23L	I/O21L	NC	VSS	I/O4L	VDD	I/O1L	I/O1R	VDD	I/O4R	VSS	NC	I/O21R	I/O23R

Selection Guide

	CY7C09579V -100	CY7C09579V -83	CY7C09579V -67	Unit
f_{MAX2} (Pipelined)	100	83	67	MHz
Max. Access Time (Clock to Data, Pipelined)	5	6	8	ns
Typical Operating Current I_{CC}	250	240	230	mA
Typical Standby Current for I_{SB1} (Both Ports TTL Level)	30	25	25	mA
Typical Standby Current for I_{SB3} (Both Ports CMOS Level)	10	10	10	μ A

Pin Definitions

Left Port	Right Port	Description
$A_{0L}-A_{13/14L}$	$A_{0R}-A_{13/14R}$	Address Inputs (A_0-A_{13} for 16K, A_0-A_{14} for 32K devices).
ADS_L	ADS_R	Address Strobe Input. Used as an address qualifier. This signal should be asserted LOW to assert the part using the externally supplied address on Address Pins. To load this address into the Burst Address Counter both ADS and CNTEN have to be LOW. ADS is disabled if CNTRST is asserted LOW
\overline{CE}_L	\overline{CE}_R	Chip Enable Input.
CLK_L	CLK_R	Clock Signal. This input can be free-running or strobed. Maximum clock input rate is f_{MAX} .
\overline{CNTEN}_L	\overline{CNTEN}_R	Counter Enable Input. Asserting this signal LOW increments the burst address counter of its respective port on each rising edge of CLK. CNTEN is disabled if CNTRST is asserted LOW.
\overline{CNTRST}_L	\overline{CNTRST}_R	Counter Reset Input. Asserting this signal LOW resets the burst address counter of its respective port to zero. CNTRST is not disabled by asserting ADS or CNTEN.
$I/O_{0L}-I/O_{35L}$	$I/O_{0R}-I/O_{35R}$	Data Bus Input/Output.
\overline{OE}_L	\overline{OE}_R	Output Enable Input. This signal must be asserted LOW to enable the I/O data pins during read operations.
R/\overline{W}_L	R/\overline{W}_R	Read/Write Enable Input. This signal is asserted LOW to write to the dual port memory array. For read operations, assert this pin HIGH.
$\overline{FT}/PIPE_L$	$\overline{FT}/PIPE_R$	Flow-Through/Pipelined Select Input. For flow-through mode operation, assert this pin LOW. For pipelined mode operation, assert this pin HIGH.
$\overline{B}_{0L}-\overline{B}_{3L}$		Byte Select Inputs. Asserting these signals enable read and write operations to the corresponding bytes of the memory array.
	BM, SIZE	Select Pins for Bus Matching. See Bus Matching for details.
	BE	Big Endian Pin. See Bus Matching for details.
V_{SS}		Ground Input.
V_{DD}		Power Input.

Maximum Ratings ^[4]

Exceeding maximum ratings may shorten the useful life of the device. User guidelines are not tested.

Storage Temperature -65 °C to +150 °C
 Ambient Temperature with
 Power Applied -55 °C to +125 °C
 Supply Voltage to Ground Potential.....-0.5 V to +4.6 V
 DC Voltage Applied to
 Outputs in High Z State -0.5 V to V_{DD} + 0.5 V
 DC Input Voltage -0.5 V to V_{DD} + 0.5 V^[5]

Output Current into Outputs (LOW)..... 20 mA
 Static Discharge Voltage..... > 2001 V
 Latch-Up Current..... > 200 mA

Operating Range

Range	Ambient Temperature	V _{DD}
Commercial	0 °C to +70 °C	3.3 V ± 165 mV
Industrial	-40 °C to +85 °C	3.3 V ± 165 mV

Electrical Characteristics

Over the Operating Range

Parameter	Description	CY7C09579V									Unit	
		-100			-83			-67				
		Min.	Typ.	Max.	Min.	Typ.	Max.	Min.	Typ.	Max.		
V _{OH}	Output HIGH Voltage (V _{DD} = Min., I _{OH} = -4.0 mA)	2.4	-	-	2.4	-	-	2.4	-	-	V	
V _{OL}	Output LOW Voltage (V _{DD} = Min., I _{OL} = +4.0 mA)	-	-	0.4	-	-	0.4	-	-	0.4	V	
V _{IH}	Input HIGH Voltage	2.0	-	-	2.0	-	-	2.0	-	-	V	
V _{IL}	Input LOW Voltage	-	-	0.8	-	-	0.8	-	-	0.8	V	
I _{OZ}	Output Leakage Current	-10	-	10	-10	-	10	-10	-	10	µA	
I _{CC}	Operating Current (V _{DD} = Max., I _{OUT} = 0 mA) Outputs Disabled	Commercial	-	250	385	-	240	360	-	230	340	mA
		Industrial	-	-	-	-	270	385	-	-	-	mA
I _{SB1}	Standby Current (Both Ports TTL Level) CE _L & CE _R ≥ V _{IH} , f = f _{MAX}	Commercial	-	30	75	-	25	70	-	25	65	mA
		Industrial	-	-	-	-	35	85	-	-	-	mA
I _{SB2}	Standby Current (One Port TTL Level) CE _L CE _R ≥ V _{IH} , f = f _{MAX}	Commercial	-	170	220	-	160	210	-	150	200	mA
		Industrial	-	-	-	-	170	235	-	-	-	mA
I _{SB3}	Standby Current (Both Ports CMOS Level) CE _L & CE _R ≥ V _{DD} - 0.2V, f = 0	Commercial	-	0.01	1	-	0.01	1	-	0.01	1	mA
		Industrial	-	-	-	-	0.01	1	-	-	-	mA
I _{SB4}	Standby Current (One Port CMOS Level) CE _L CE _R ≥ V _{IH} , f = f _{MAX}	Commercial	-	150	200	-	140	190	-	130	180	mA
		Industrial	-	-	-	-	150	200	-	-	-	mA

Capacitance

Parameter	Description	Test Conditions	Max.	Unit
C _{IN}	Input Capacitance	T _A = 25 °C, f = 1 MHz, V _{DD} = 3.3 V	10	pF
C _{OUT}	Output Capacitance		10	pF

Notes

- The voltage on any input or I/O pin can not exceed the power pin during power-up.
- Pulse width < 20 ns.

AC Test Load and Waveforms

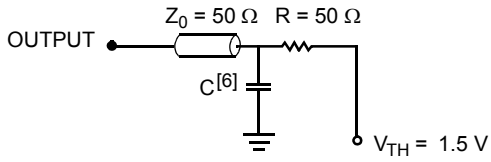

(a) Normal Load (Load 1)

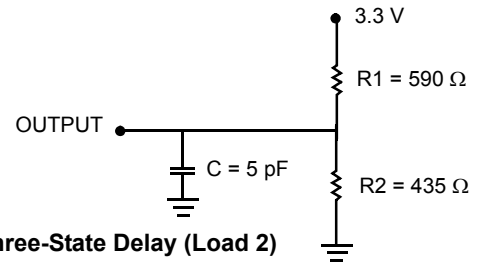

(b) Three-State Delay (Load 2)

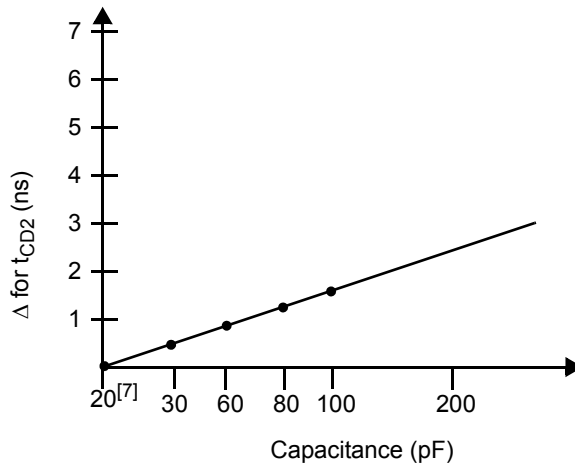
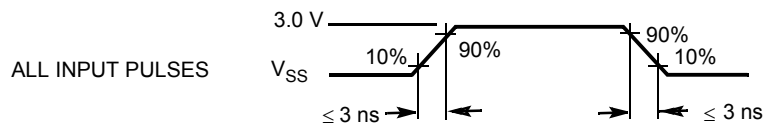

(b) Load Derating Curve

Notes

- 6. External AC Test Load Capacitance = 10 pF.
- 7. (Internal I/O pad Capacitance = 10 pF) + AC Test Load.

Switching Characteristics

Over the Operating Range

Parameter	Description	CY7C09579V						Unit
		-100		-83		-67		
		Min	Max	Min	Max	Min	Max	
f _{MAX1}	f _{Max} Flow-Through	–	67	–	45	–	40	MHz
f _{MAX2}	f _{Max} Pipelined	–	100	–	83	–	67	MHz
t _{CYC1}	Clock Cycle Time - Flow-Through	15	–	22	–	25	–	ns
t _{CYC2}	Clock Cycle Time - Pipelined	10	–	12	–	15	–	ns
t _{CH1}	Clock HIGH Time - Flow-Through	6.5	–	7.5	–	8.5	–	ns
t _{CL1}	Clock LOW Time - Flow-Through	6.5	–	7.5	–	8.5	–	ns
t _{CH2}	Clock HIGH Time - Pipelined	4	–	5	–	6.5	–	ns
t _{CL2}	Clock LOW Time - Pipelined	4	–	5	–	6.5	–	ns
t _R	Clock Rise Time	–	3	–	3	–	3	ns
t _F	Clock Fall Time	–	3	–	3	–	3	ns
t _{SA}	Address Set-Up Time	3.5	–	4	–	4	–	ns
t _{HA}	Address Hold Time	0.5	–	0.5	–	0.5	–	ns
t _{SB}	Byte Select Set-Up Time	3.5	–	4	–	4	–	ns
t _{HB}	Byte Select Hold Time	0.5	–	0.5	–	0.5	–	ns
t _{SC}	Chip Enable Set-Up Time	3.5	–	4	–	4	–	ns
t _{HC}	Chip Enable Hold Time	0.5	–	0.5	–	0.5	–	ns
t _{SW}	R/W Set-Up Time	3.5	–	4	–	4	–	ns
t _{HW}	R/W Hold Time	0.5	–	0.5	–	0.5	–	ns
t _{SD}	Input Data Set-Up Time	3.5	–	4	–	4	–	ns
t _{HD}	Input Data Hold Time	0.5	–	0.5	–	0.5	–	ns
t _{SAD}	ADS Set-Up Time	3.5	–	4	–	4	–	ns
t _{HAD}	ADS Hold Time	0.5	–	0.5	–	0.5	–	ns
t _{SCN}	CNTEN Set-Up Time	3.5	–	4	–	4	–	ns
t _{HCN}	CNTEN Hold Time	0.5	–	0.5	–	0.5	–	ns
t _{SRST}	CNTRST Set-Up Time	3.5	–	4	–	4	–	ns
t _{HRST}	CNTRST Hold Time	0.5	–	0.5	–	0.5	–	ns
t _{OE}	Output Enable to Data Valid	–	8	–	9	–	10	ns
t _{OLZ} ^[8, 9]	OE to Low Z	2	–	2	–	2	–	ns
t _{OHZ} ^[8, 9]	OE to High Z	1	7	1	7	1	7	ns
t _{CD1}	Clock to Data Valid - Flow-Through	–	12.5	–	18	–	20	ns
t _{CD2}	Clock to Data Valid - Pipelined	–	5	–	6	–	8	ns
t _{CA1}	Clock to Counter Address Valid - Flow-Through	–	12.5	–	18	–	20	ns
t _{CA2}	Clock to Counter Address Valid - Pipelined	–	9	–	10	–	11	ns
t _{DC}	Data Output Hold After Clock HIGH	2	–	2	–	2	–	ns

Notes

- 8. This parameter is guaranteed by design, but it is not production tested.
- 9. Test conditions used are Load 2.

Switching Characteristics

Over the Operating Range (*continued*)

Parameter	Description	CY7C09579V						Unit
		-100		-83		-67		
		Min	Max	Min	Max	Min	Max	
$t_{CKHZ}^{[10, 11]}$	Clock HIGH to Output High Z	2	6	2	7	2	8	ns
$t_{CKLZ}^{[10, 11]}$	Clock HIGH to Output Low Z	2	–	2	–	2	–	ns
Port to Port Delays								
t_{CWDD}	Write Port Clock HIGH to Read Data Delay	–	30	–	35	–	35	ns
t_{CCS}	Clock to Clock Set-Up Time	–	9	–	10	–	12	ns

Notes

10. This parameter is guaranteed by design, but it is not production tested.
 11. Test conditions used are Load 2.

Switching Waveforms

Read Cycle for Flow-Through Output ($\overline{\text{FT}}/\text{PIPE} = V_{\text{IL}}$)^[12, 13, 14, 15]

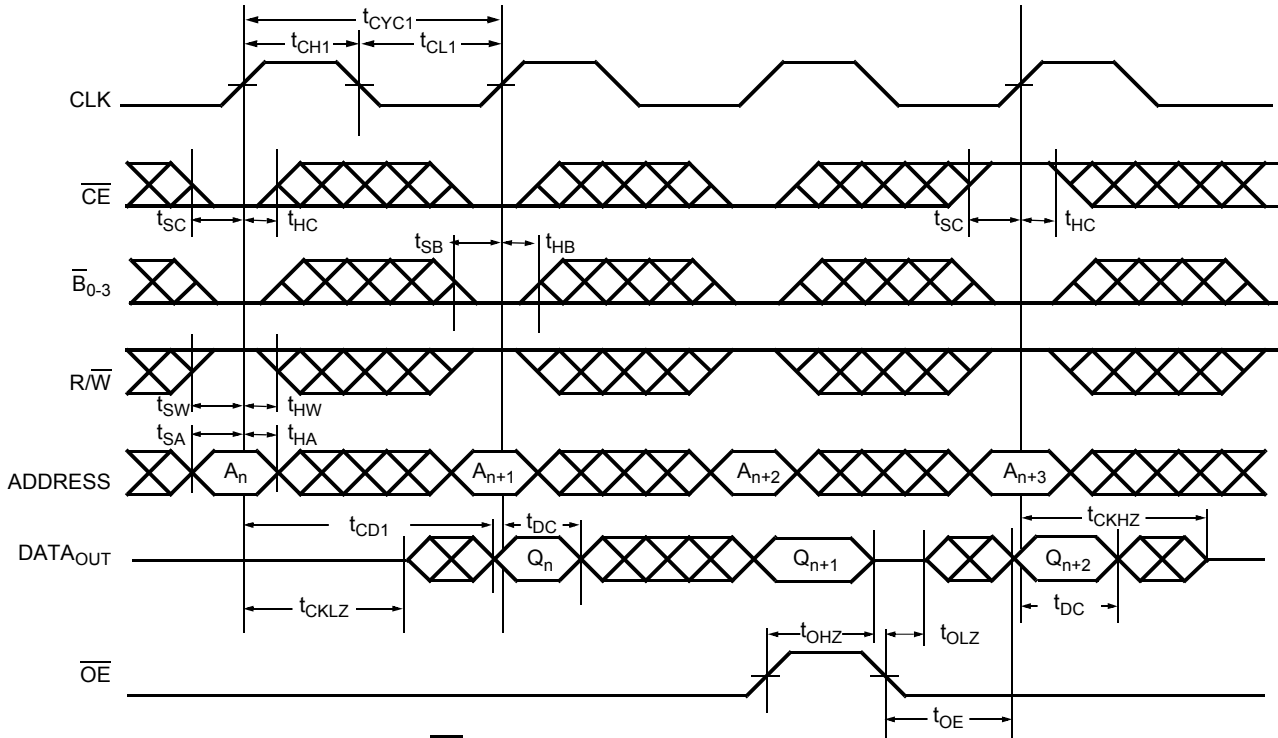

Read Cycle for Pipelined Operation ($\overline{\text{FT}}/\text{PIPE} = V_{\text{IH}}$)^[12, 13, 14, 15]

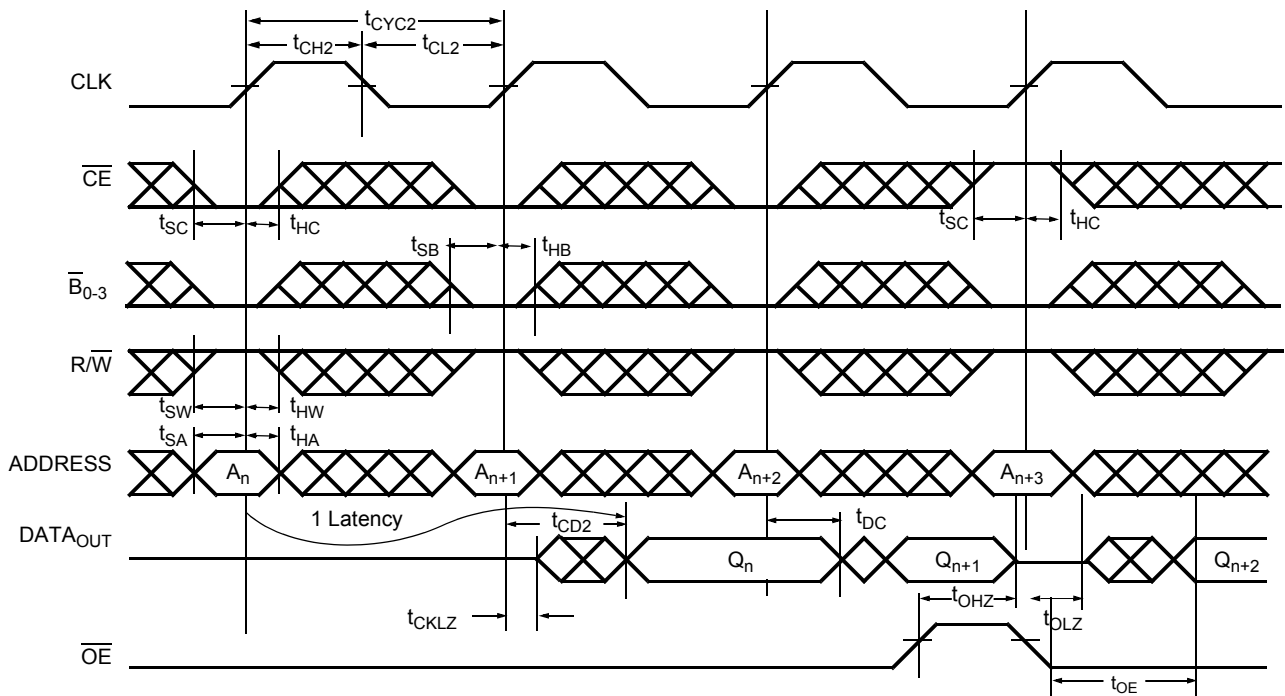

Notes

12. $\overline{\text{OE}}$ is asynchronously controlled; all other inputs are synchronous to the rising clock edge.
13. $\text{ADS} = V_{\text{IL}}$, $\text{CNTEN} = V_{\text{IL}}$ and $\text{CNTRST} = V_{\text{IH}}$.
14. The output is disabled (high-impedance state) by $\overline{\text{CE}} = V_{\text{IH}}$ following the next rising edge of the clock.
15. Addresses do not have to be accessed sequentially since $\text{ADS} = V_{\text{IL}}$ constantly loads the address on the rising edge of the CLK. Numbers are for reference only.

Switching Waveforms (continued)

Bank Select Pipelined Read^[21, 22]

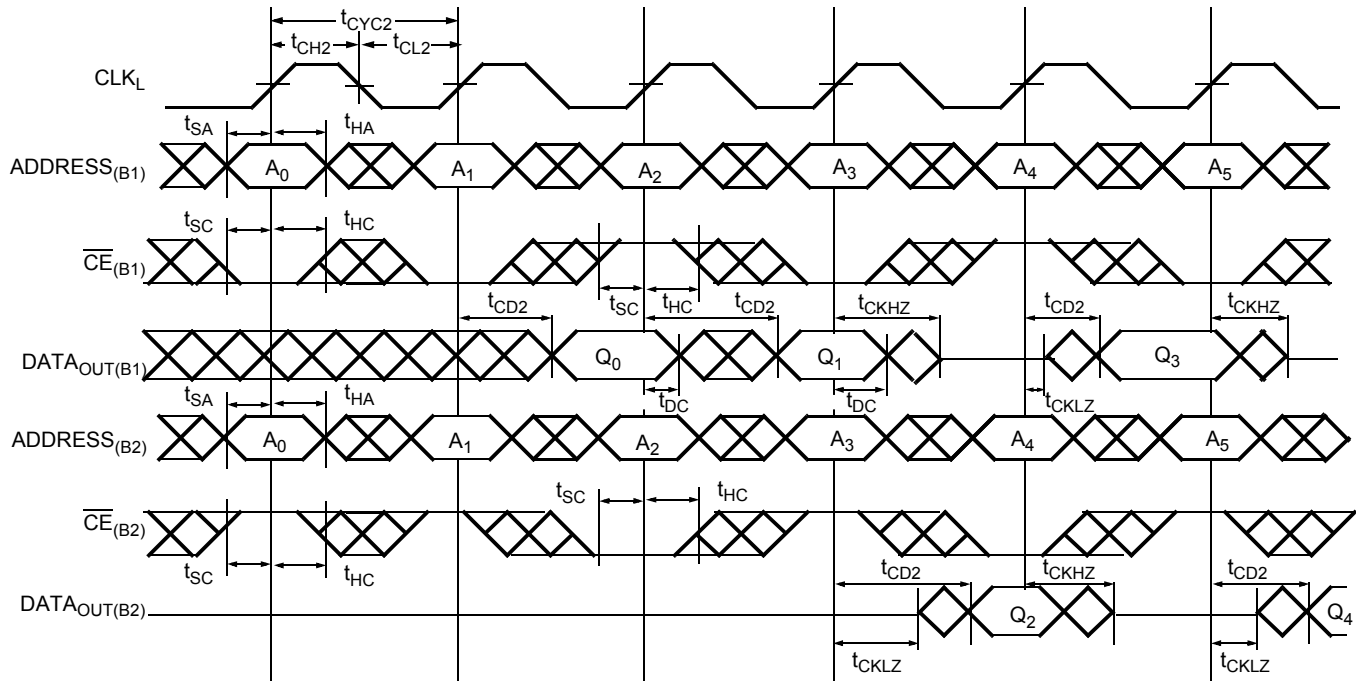

Left Port Write to Flow-Through Right Port Read^[22, 23, 24, 25, 26]

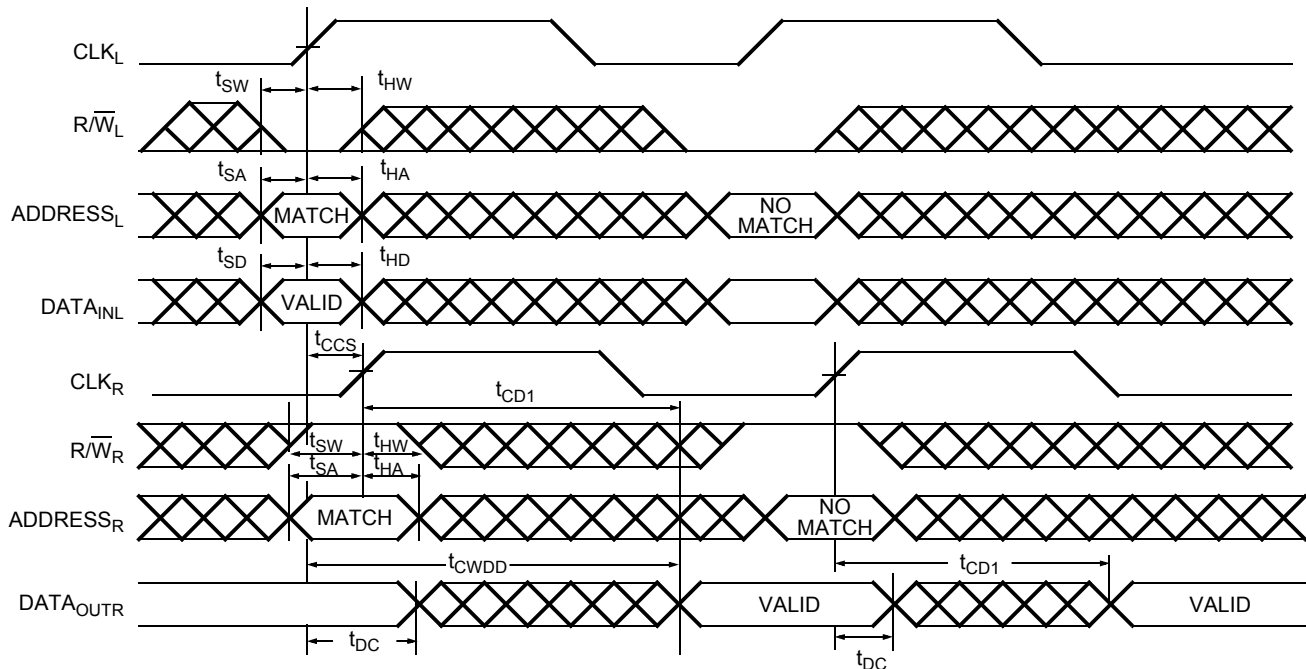

Notes

21. In this depth expansion example, B1 represents Bank #1 and B2 is Bank #2; Each Bank consists of one Cypress dual-port device from this data sheet.
22. $\overline{ADDRESS}_{(B1)} = \overline{ADDRESS}_{(B2)}$.
23. $B0 = B1 = B2 = B3 = BM = SIZE = \overline{ADS} = \overline{CNTEN} = V_{IL}$, $\overline{CNTRST} = V_{IH}$.
24. The same waveforms apply for a right port write to flow-through left port read.
25. $\overline{CE} = B0 = B1 = B2 = B3 = \overline{ADS} = \overline{CNTEN} = V_{IL}$, $\overline{CNTRST} = V_{IH}$.
26. If $t_{CCS} \leq$ maximum specified, then data from right port READ is not valid until the maximum specified for t_{CWDD} . If $t_{CCS} >$ maximum specified, then data is not valid until $t_{CCS} + t_{CD1}$ (t_{CWDD} does not apply in this case).

Switching Waveforms (continued)

Pipelined Read-to-Write-to-Read ($\overline{OE} = V_{IL}$)^[27, 28, 29, 30]

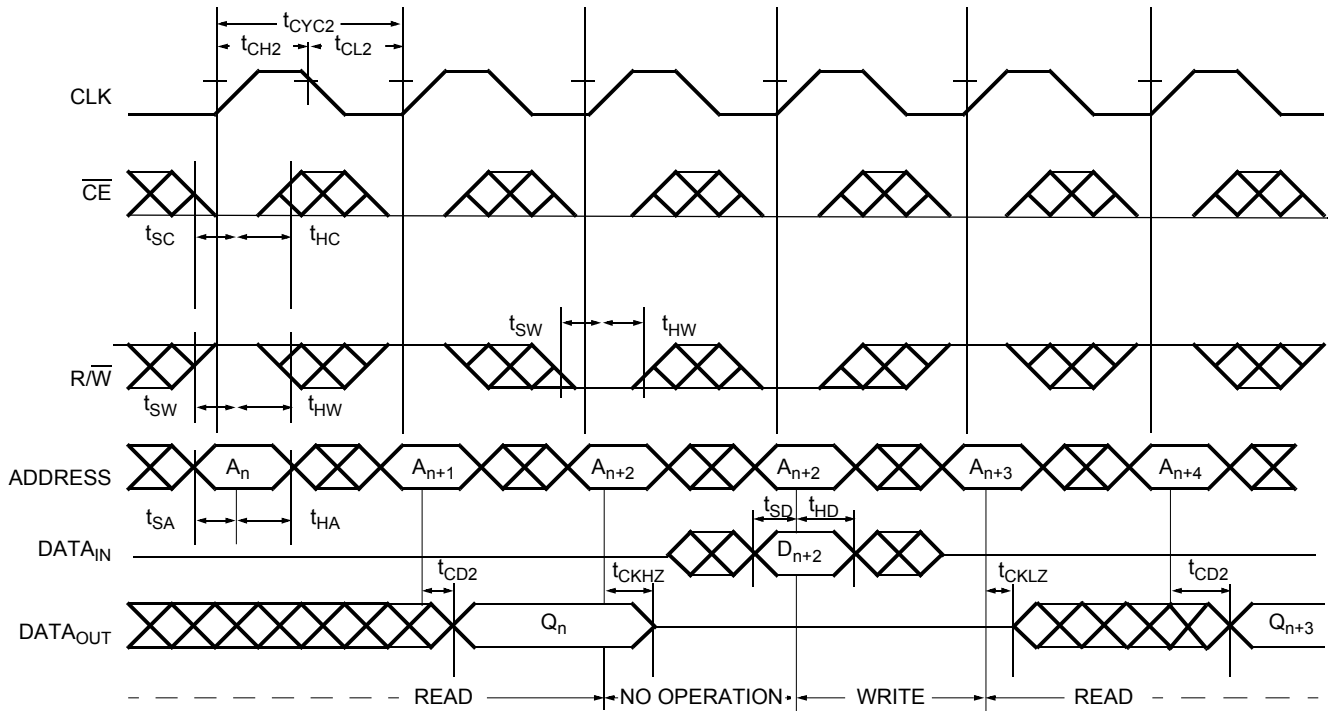

Notes

- 27. Addresses do not have to be accessed sequentially since $\overline{ADS} = V_{IL}$ constantly loads the address on the rising edge of the CLK. Numbers are for reference only.
- 28. Output state (HIGH, LOW, or High-Impedance) is determined by the previous cycle control signals.
- 29. $CE = ADS = CNTEN = V_{IL}$; $CNTRST = V_{IH}$.
- 30. During "No Operation," data in memory at the selected address may be corrupted and should be rewritten to ensure data integrity.

Switching Waveforms (continued)

Pipelined Read-to-Write-to-Read (\overline{OE} Controlled)^[31, 32, 33, 34]

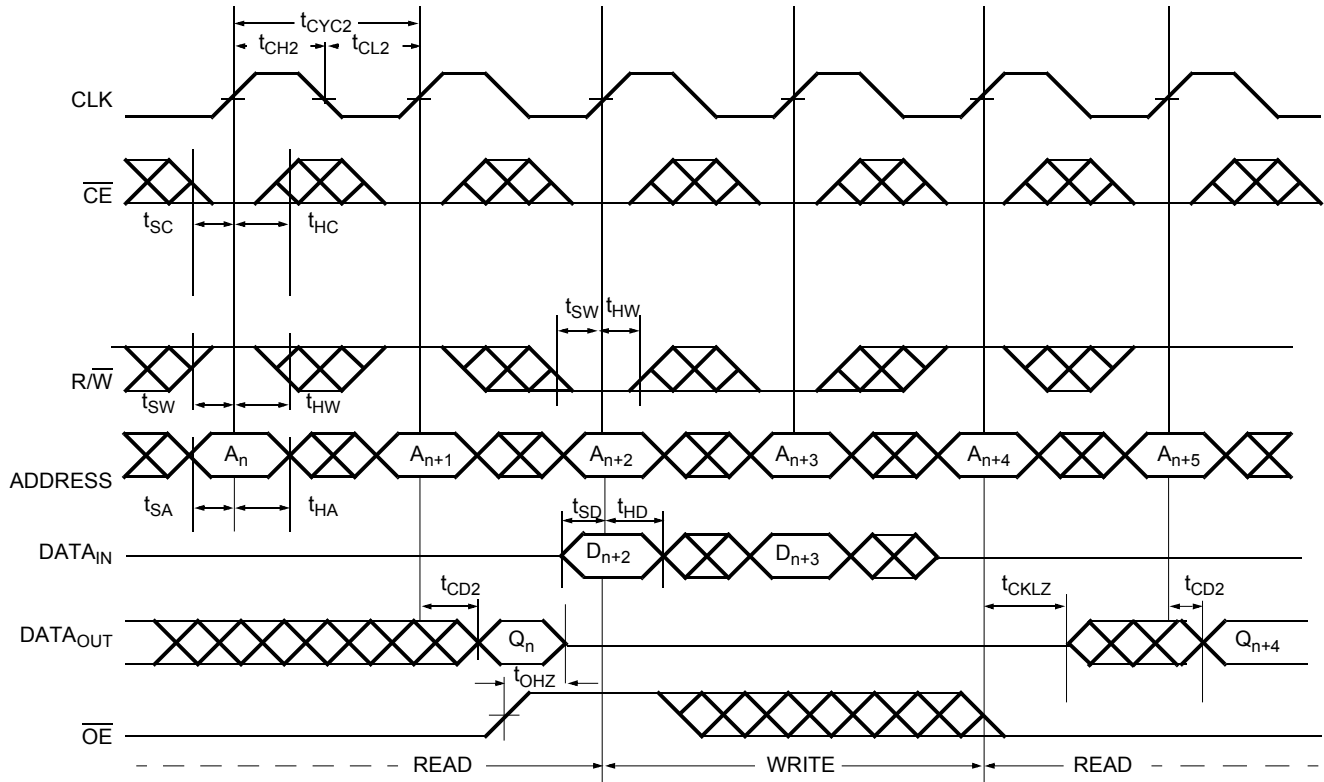

Notes

- 31. Test conditions used are Load 2.
- 32. Output state (HIGH, LOW, or High-Impedance) is determined by the previous cycle control signals.
- 33. CE = ADS = CNTEN = V_{IL}; CNTRST = V_{IH}.
- 34. During "No Operation," data in memory at the selected address may be corrupted and should be rewritten to ensure data integrity.

Switching Waveforms (continued)

Bus Match Pipelined Read-to-Write-to-Read ($\overline{OE} = V_{IL}$) [35, 36, 37, 38, 39, 40, 41]

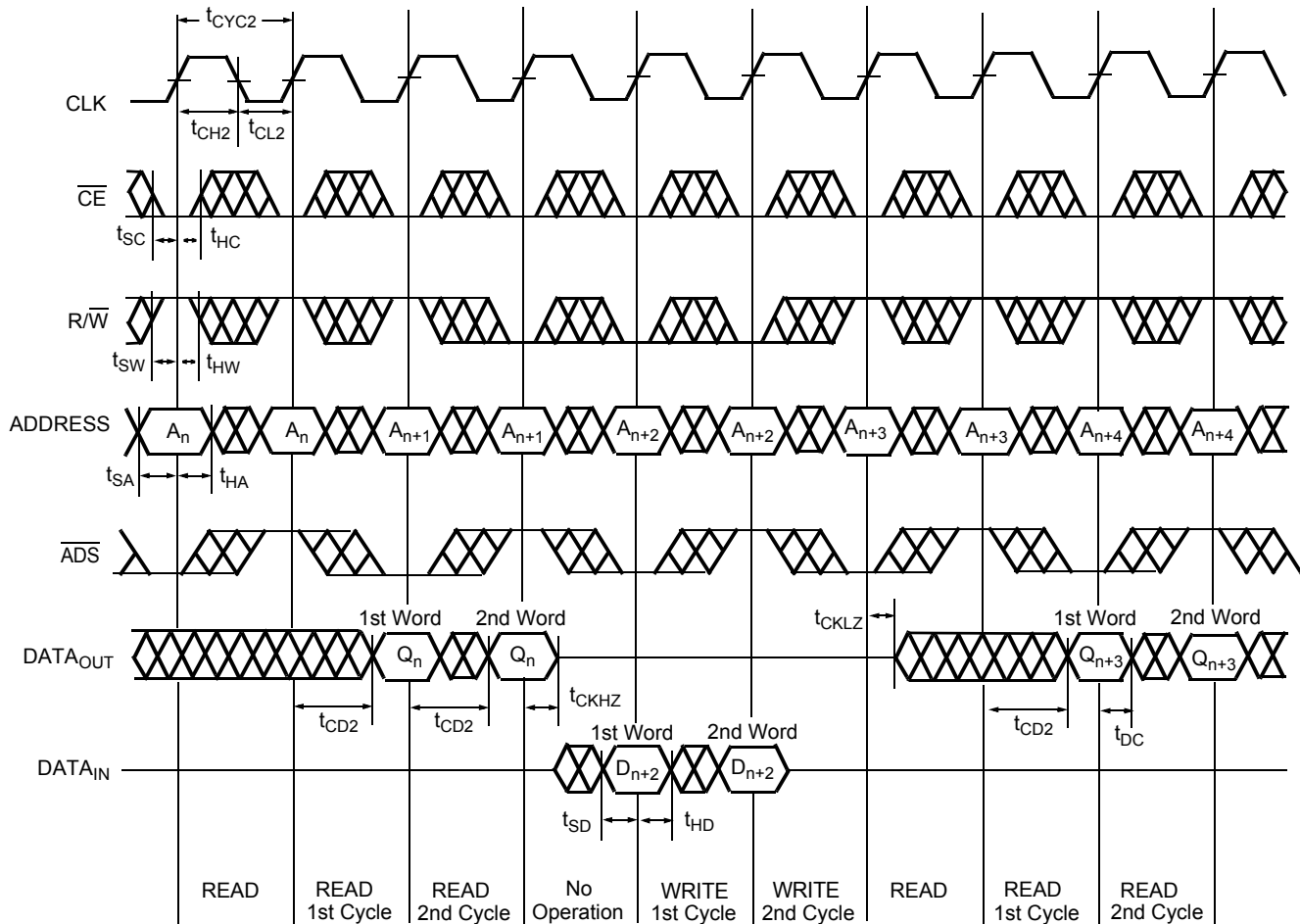

Notes

- 35. Test conditions used are Load 2.
- 36. Timing shown is for x18 bus matching; x9 bus matching is similar with 4 cycles between address inputs.
- 37. See table "Right Port Operation" for data output on first and subsequent cycles.
- 38. $\overline{CNTEN} = V_{IL}$. In x9 and x18 Bus Matching Burst Mode operations (Write or Read), \overline{ADS} can toggle on the rising edge of every clock cycle or it can be at V_{IH} level all the time except when loading the initial external address (i.e. $\overline{ADS} = V_{IL}$ only required when reading or writing the first Byte or Word).
- 39. $\overline{CE} = \overline{ADS} = \overline{CNTEN} = V_{IL}$; $\overline{CNTRST} = V_{IH}$.
- 40. During "No Operation," data in memory at the selected address may be corrupted and should be rewritten to ensure data integrity.
- 41. BM, SIZE, and BE must be reconfigured 1 cycle before operation is guaranteed. BM, SIZE, and BE should remain static for any particular port configuration.

Switching Waveforms (continued)

Flow-Through Read-to-Write-to-Read ($\overline{OE} = V_{IL}$)^[42, 43, 44, 45, 46, 47]

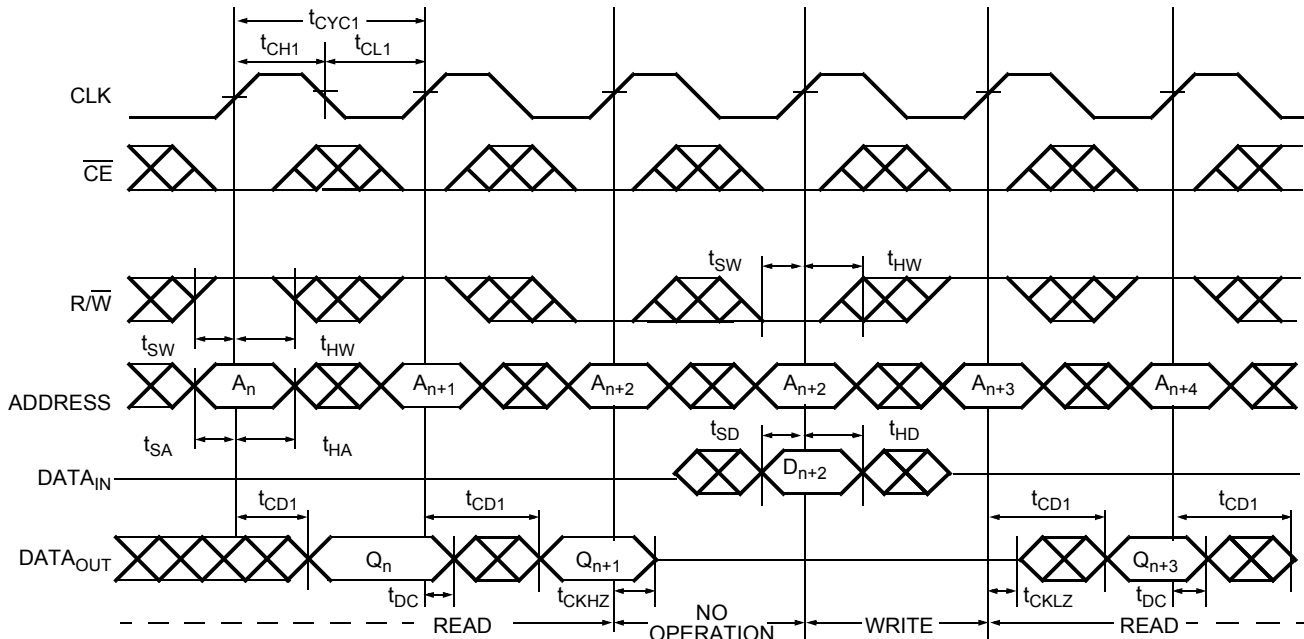

Flow-Through Read-to-Write-to-Read (\overline{OE} Controlled)^[42, 43, 46, 47, 48]

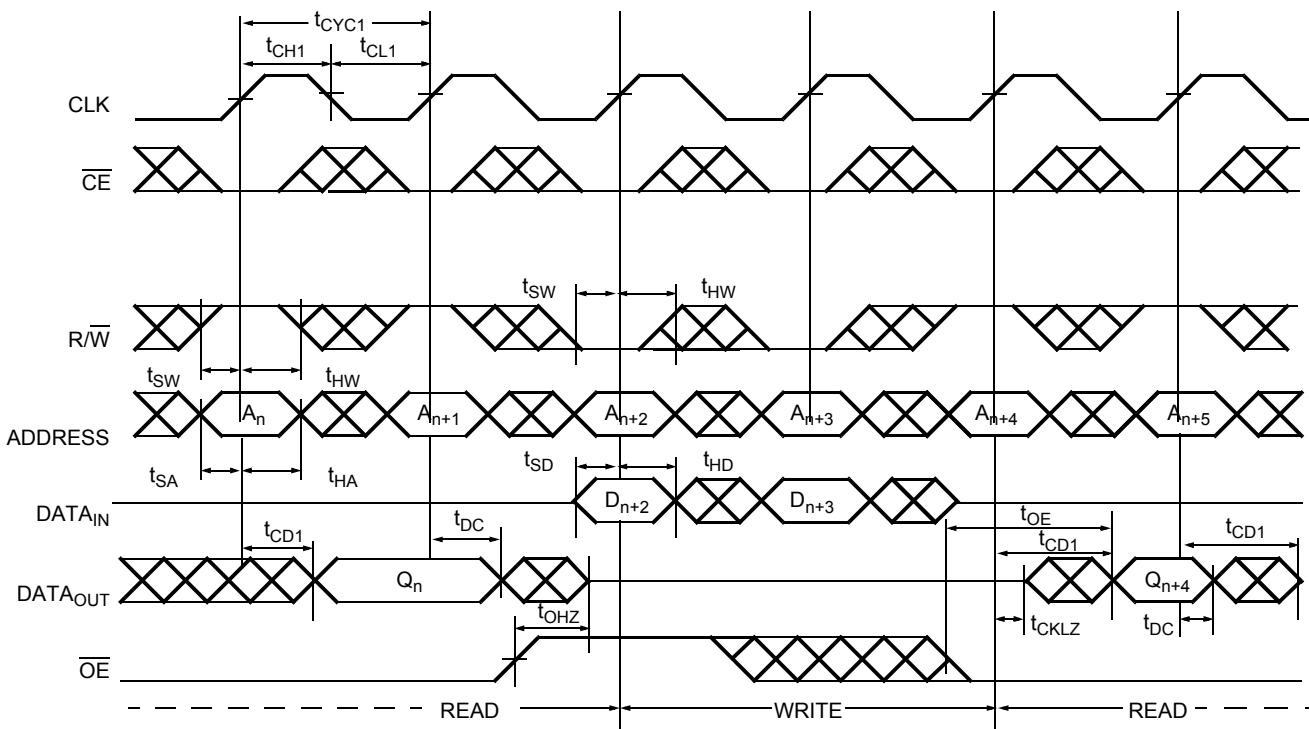

Notes

- 42. $\overline{ADS} = V_{IL}$, $\overline{CNTEN} = V_{IL}$ and $\overline{CNTRST} = V_{IH}$.
- 43. Addresses do not have to be accessed sequentially since $\overline{ADS} = V_{IL}$ constantly loads the address on the rising edge of the CLK. Numbers are for reference only.
- 44. Timing shown is for x18 bus matching; x9 bus matching is similar with 4 cycles between address inputs.
- 45. See table "Right Port Operation" for data output on first and subsequent cycles.
- 46. $\overline{CE} = \overline{ADS} = \overline{CNTEN} = V_{IL}$; $\overline{CNTRST} = V_{IH}$.
- 47. During "No Operation," data in memory at the selected address may be corrupted and should be rewritten to ensure data integrity.
- 48. Output state (HIGH, LOW, or High-Impedance) is determined by the previous cycle control signals.

Switching Waveforms (continued)

Bus Match Flow-Through Read-to-Write-to-Read ($\overline{OE} = V_{IL}$)^[49, 50, 51, 52, 53, 54, 55]

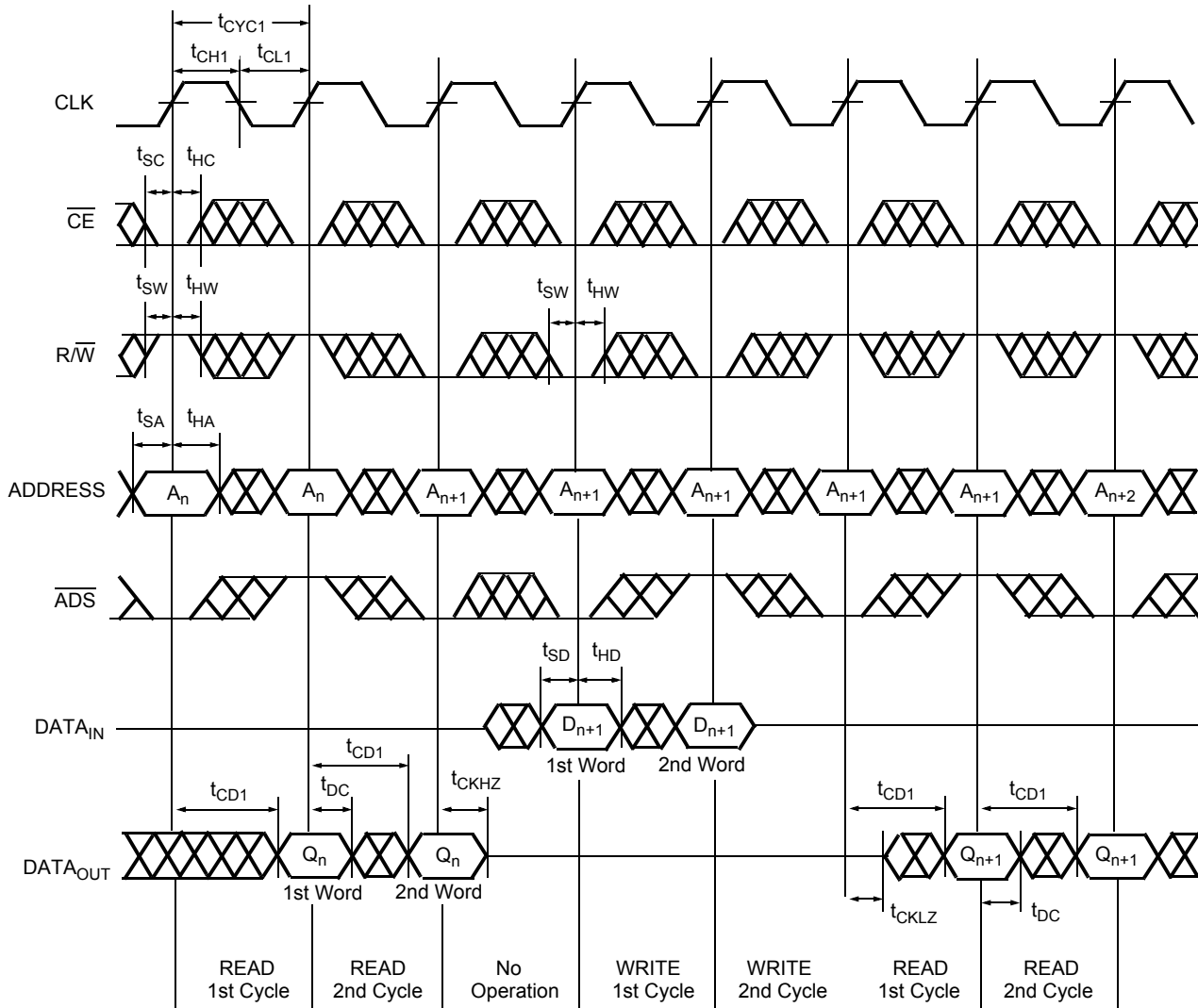

Notes

- 49. Test conditions used are Load 2.
- 50. Timing shown is for x18 bus matching; x9 bus matching is similar with 4 cycles between address inputs.
- 51. See table "Right Port Operation" for data output on first and subsequent cycles.
- 52. $\overline{CNTEN} = V_{IL}$. In x9 and x18 Bus Matching Burst Mode operations (Write or Read), \overline{ADS} can toggle on the rising edge of every clock cycle or it can be at V_{IH} level all the time except when loading the initial external address (i.e. $\overline{ADS} = V_{IL}$ only required when reading or writing the first Byte or Word).
- 53. $\overline{CE} = \overline{ADS} = \overline{CNTEN} = V_{IL}$; $\overline{CNTRST} = V_{IH}$.
- 54. During "No Operation," data in memory at the selected address may be corrupted and should be rewritten to ensure data integrity.
- 55. BM, SIZE, and BE must be reconfigured 1 cycle before operation is guaranteed. BM, SIZE, and BE should remain static for any particular port configuration.

Switching Waveforms (continued)

Pipelined Read with Address Counter Advance^[56]

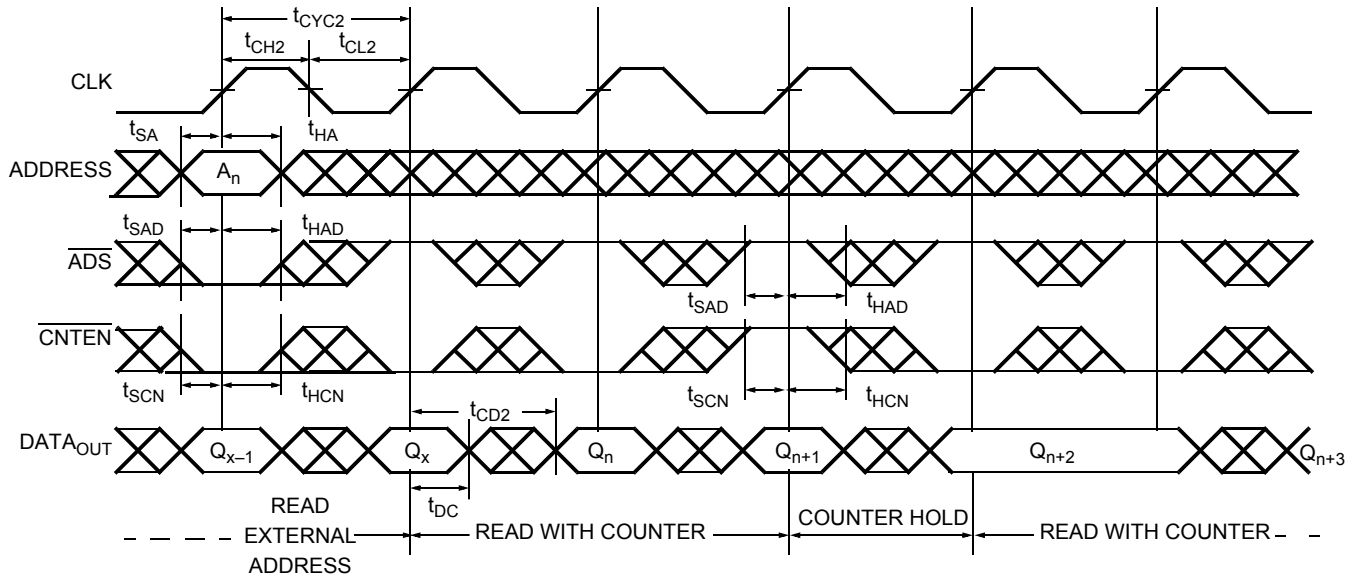

Flow-Through Read with Address Counter Advance^[56]

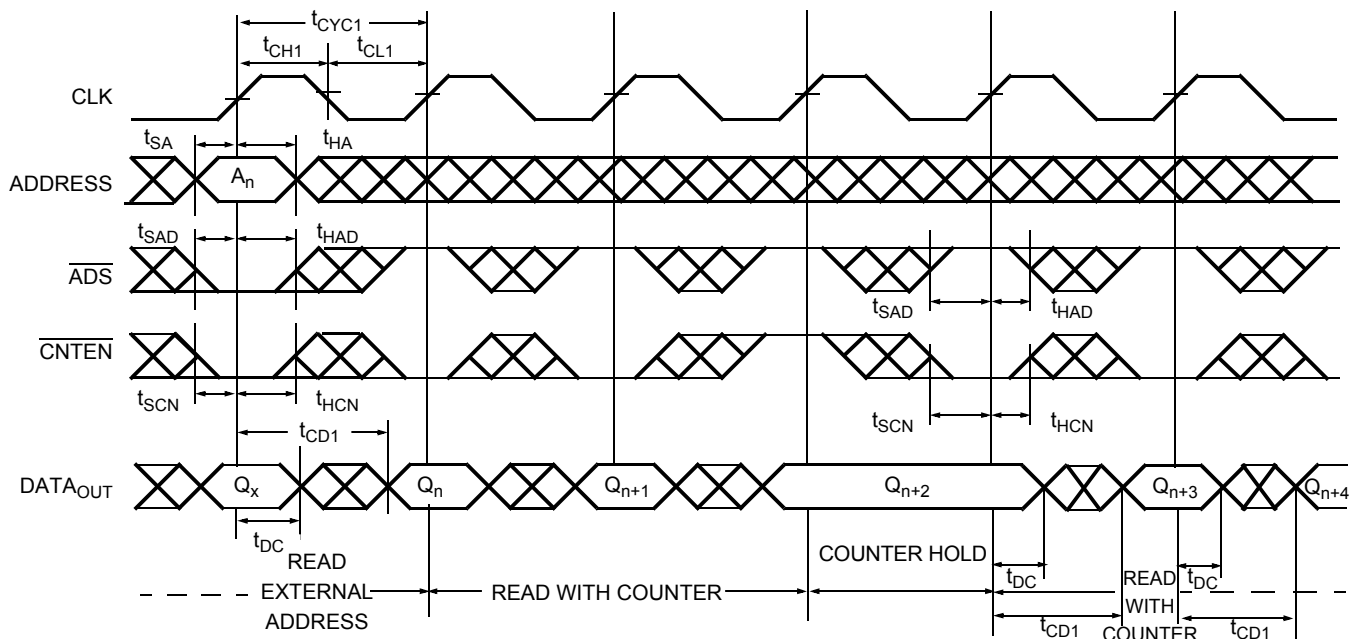

Note
56. $\overline{CE} = \overline{OE} = V_{IL}$; $R/\overline{W} = \overline{CNTRST} = V_{IH}$.

Switching Waveforms (continued)

Write with Address Counter Advance (Flow-Through or Pipelined Outputs)^[57, 58]

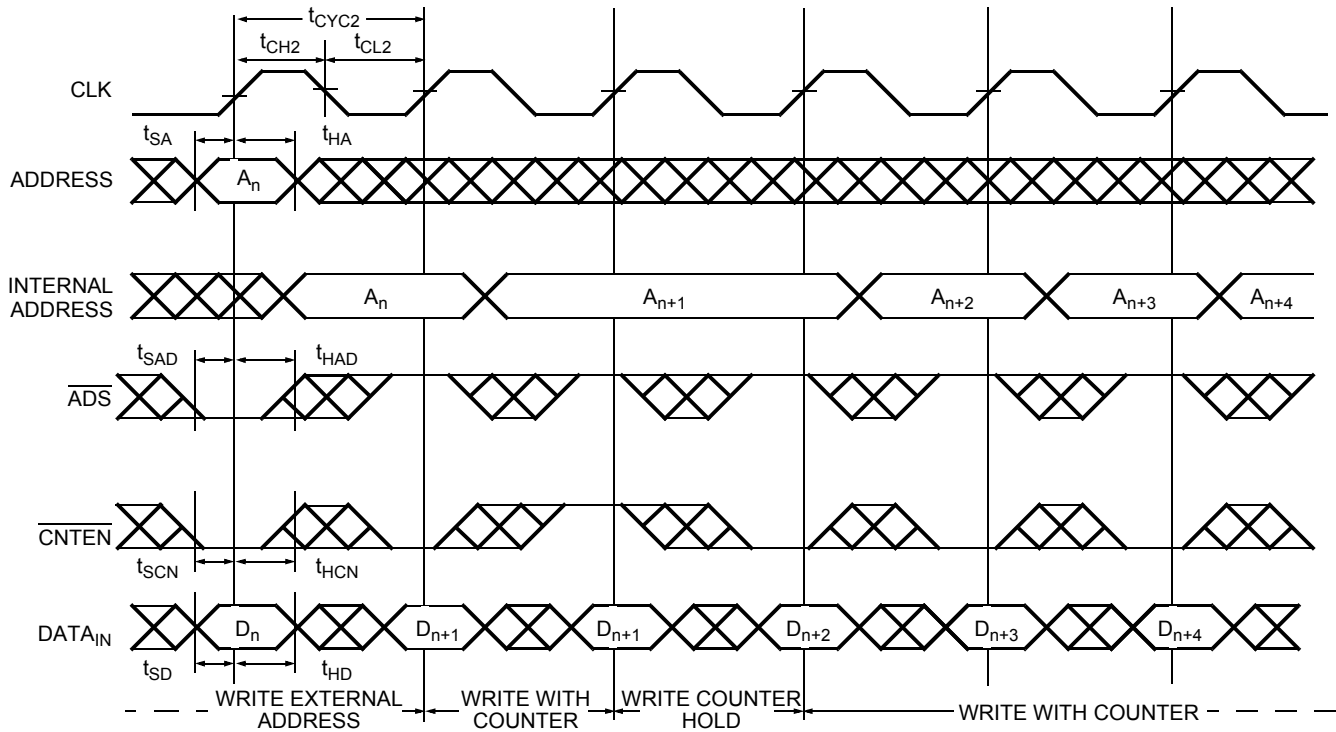

Notes

57. $\overline{CE} = \overline{B0} = \overline{B1} = \overline{B2} = \overline{B3} = R\overline{W} = V_{IL}$; $\overline{CNTRST} = V_{IH}$.

58. The "Internal Address" is equal to the "External Address" when $\overline{ADS} = \overline{CNTEN} = V_{IL}$ and $\overline{CNTRST} = V_{IH}$.

Switching Waveforms (continued)

Counter Reset (Pipelined Outputs)^[59, 60, 61, 62, 63]

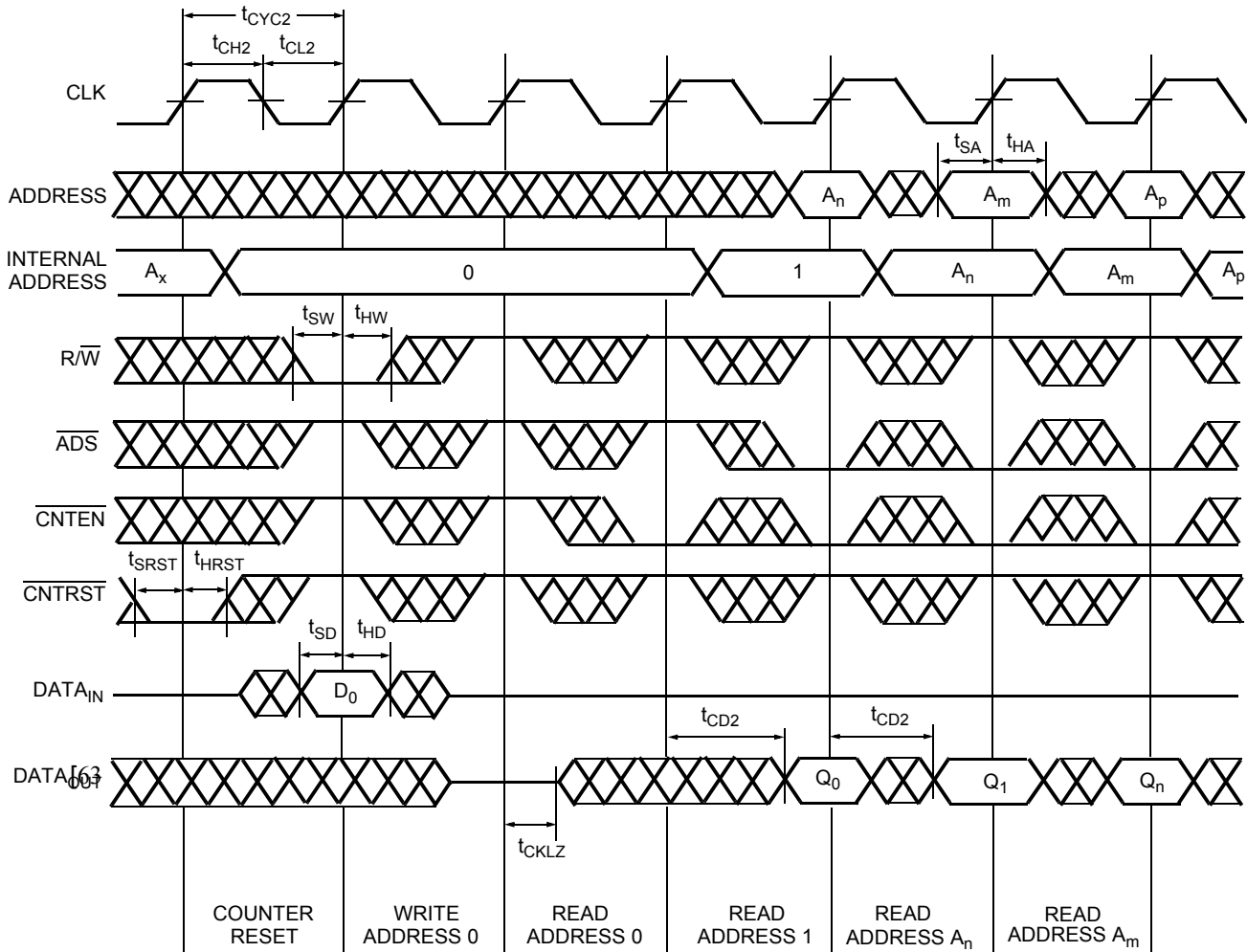

Notes

- 59. Test conditions used are Load 2.
- 60. Output state (HIGH, LOW, or High-Impedance) is determined by the previous cycle control signals.
- 61. $CE = B0 = B1 = B2 = B3 = V_{IL}$.
- 62. No dead cycle exists during counter reset. A READ or WRITE cycle may be coincidental with the counter reset.
- 63. Output state (HIGH, LOW, or High-Impedance) is determined by the previous cycle control signals. Ideally, DATA_{OUT} should be in the High-Impedance state during a valid WRITE cycle.

Switching Waveforms (continued)

Counter Reset (Flow-Through Outputs) [64, 65, 66, 67, 68]

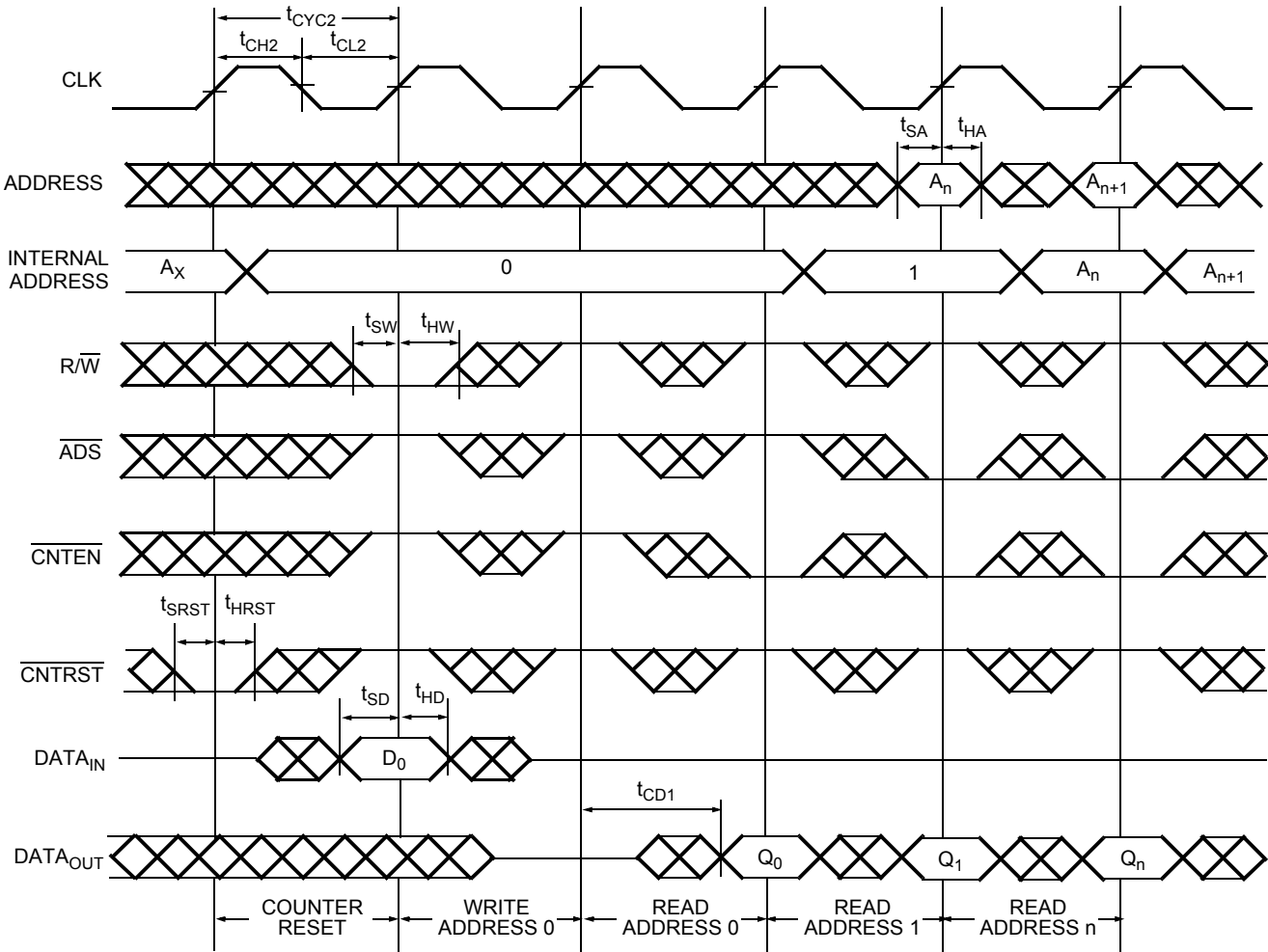

Notes

- 64. Output state (HIGH, LOW, or High-Impedance) is determined by the previous cycle control signals.
- 65. During "No Operation," data in memory at the selected address may be corrupted and should be rewritten to ensure data integrity.
- 66. $CE = B0 = B1 = B2 = B3 = V_{IL}$.
- 67. No dead cycle exists during counter reset. A READ or WRITE cycle may be coincidental with the counter reset.
- 68. Output state (HIGH, LOW, or High-Impedance) is determined by the previous cycle control signals. Ideally, DATA_{OUT} should be in the High-Impedance state during a valid WRITE cycle.

Switching Waveforms (continued)

Pipelined Read of State of Address Counter [69, 70, 71]

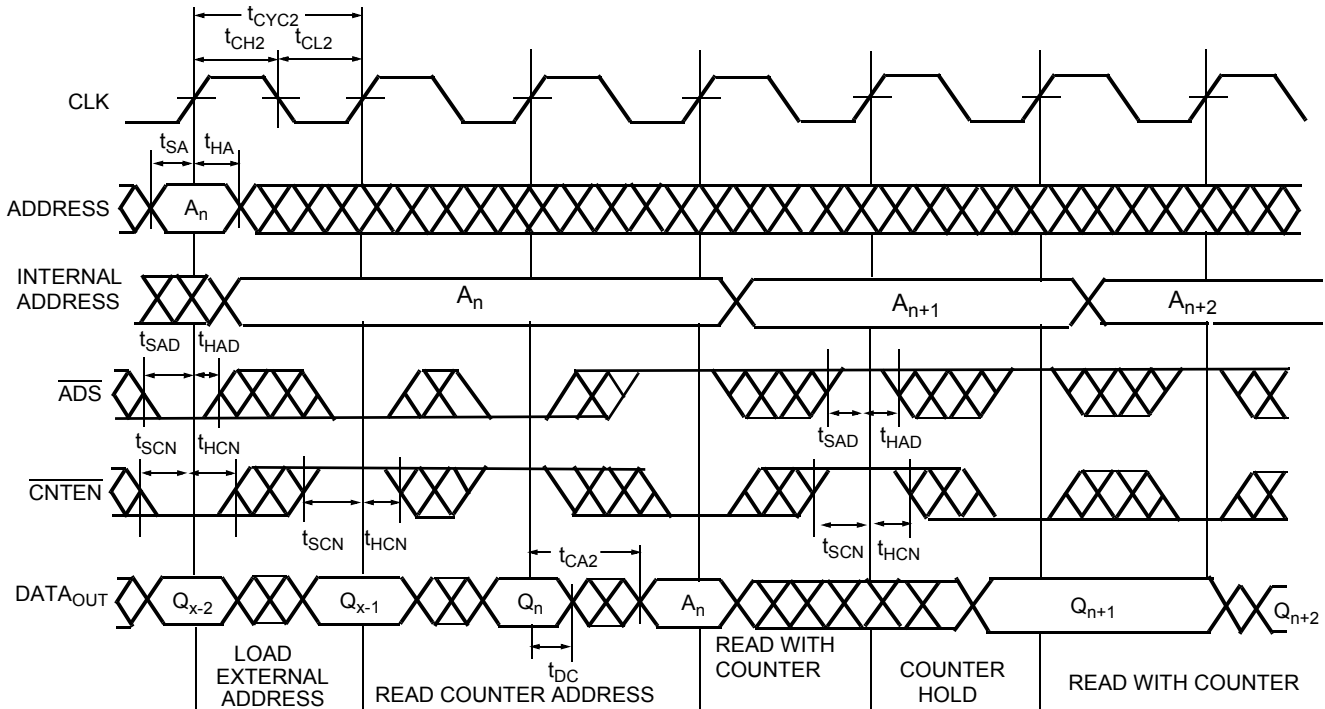

Flow-Through Read of State of Address Counter [69, 70, 72]

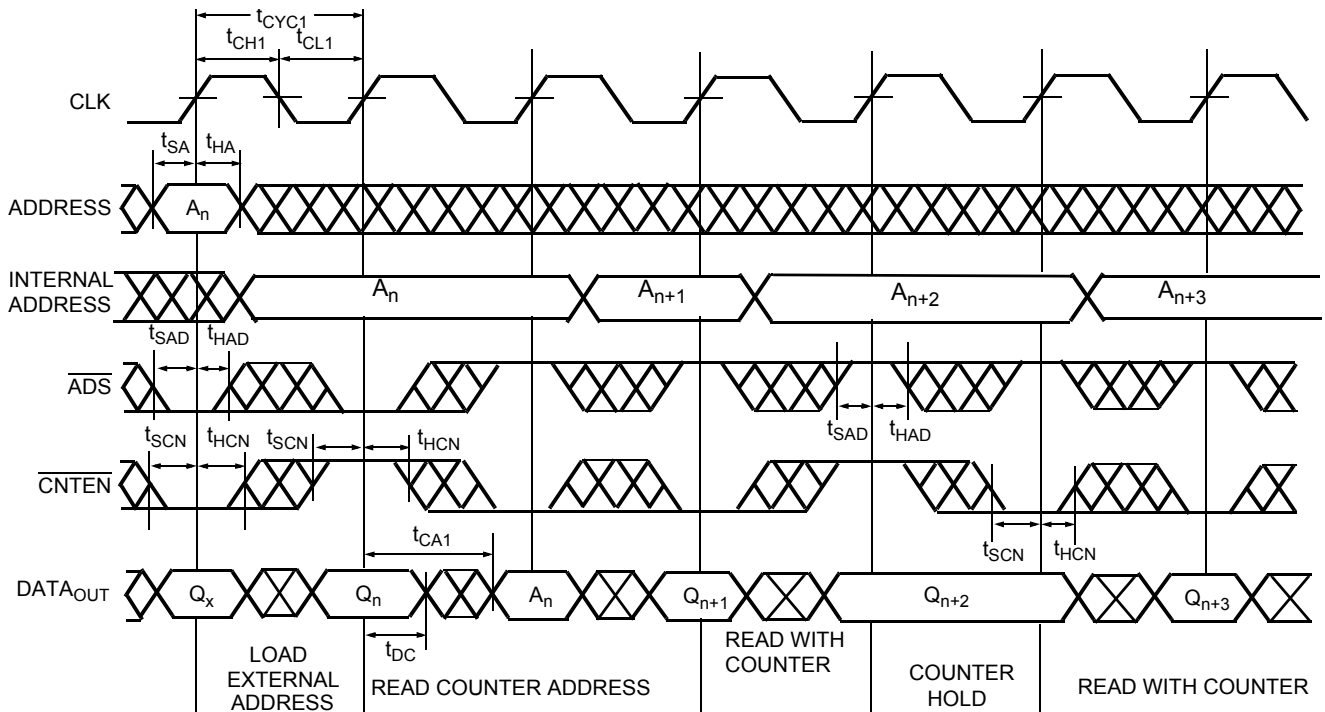

Notes



69. $\overline{CE} = \overline{OE} = V_{IL}$; $R/\overline{W} = \overline{CNT\overline{RST}} = V_{IH}$.

70. When reading ADDRESS_{OUT} in x9 Bus Match mode, readout of A_n is extended by 1 cycle.





71. For Pipelined address counter read, signals from address counter operation table from must be valid for 2 consecutive cycles for x36 and x18 mode and for 3 consecutive cycles for x9 mode.

72. For flow-through address counter read, signals from address counter operation table must be valid for consecutive cycles for x36.

Read/Write and Enable Operation^[73, 74, 75]

Inputs				Outputs	Operation
OE	CLK	CE	R/W	I/O ₀ -I/O ₃₅	
X		H	X	High Z	Deselected ^[76]
X		L	L	D _{IN}	Write
L		L	H	D _{OUT}	Read ^[76]
H	X	L	X	High Z	Outputs Disabled

Address Counter Control Operation^[73, 77]

Address	Previous Address	CLK	OE	R/W	ADS	CNTEN	CNTRST	Mode	Operation
X	X		X	X	X	X	L	Reset	Counter Reset
A _n	X		X	X	L	L	H	Load	Address Load into Counter
A _n	A _n		L	H	L	H	H	Hold + Read	External Address Blocked - Counter Address Readout
X	A _n		X	X	H	H	H	Hold	External Address Blocked - Counter Disabled
X	A _n		X	X	H	L	H	Increment	Counter Increment

Notes

73. "X" = "Don't Care." "H" = V_{IHI}. "L" = V_{IL}.

74. ADS, CNTEN, CNTRST = "Don't Care."

75. OE is an asynchronous input signal.

76. When CE changes state in the pipelined mode, deselection and read happen in the following clock cycle.

77. Counter operation is independent of CE.

Right Port Configuration^[78, 79]

BM	SIZE	Configuration	I/O Pins used
0	0	x36	I/O _{0R-35R}
1	0	x18	I/O _{0R-17R}
1	1	x9	I/O _{0R-8R}

Right Port Operation^[80]

Configuration	BE	Data on 1st Cycle	Data on 2nd Cycle	Data on 3rd Cycle	Data on 4th Cycle
x18	0	DQ _{0R-17R}	DQ _{18R-35R}	-	-
x18	1	DQ _{18R-35R}	DQ _{0R-17R}	-	-
x9	0	DQ _{0R-8R}	DQ _{9R-17R}	DQ _{18R-26R}	DQ _{27R-35R}
x9	1	DQ _{27R-35R}	DQ _{18R-26R}	DQ _{9R-17R}	DQ _{0R-8R}

Readout of Internal Address Counter^[81]

Configuration	Address on 1st Cycle	I/O Pins used on 1st Cycle	Address on 2nd Cycle	I/O Pins used on 2nd Cycle
Left Port x36	A _{0L-14L}	I/O _{3L-17L}	-	-
Right Port x36	A _{0R-14R}	I/O _{3R-17R}	-	-
Right Port x18	WA, A _{0R-14R}	I/O _{2R-17R}	-	-
Right Port x9	A _{6R-14R}	I/O _{0R-8R}	BA, WA, A _{0R-5R}	I/O _{1R-8R}

Left Port Operation

Control Pin	Effect
$\overline{B0}$	I/O ₀₋₈ Byte Control
$\overline{B1}$	I/O ₉₋₁₇ Byte Control
$\overline{B2}$	I/O ₁₈₋₂₆ Byte Control
$\overline{B3}$	I/O ₂₇₋₃₅ Byte Control

Notes

78. BM, SIZE, and BE must be reconfigured 1 cycle before operation is guaranteed. BM, SIZE, and BE should remain static for any particular port configuration.

79. In x36 mode, BE input is a "Don't Care."

80. DQ represents data output of the chip.

81. x18 and x9 configuration apply to right port only.

Counter Operation

The CY7C09569V/09579V Dual-Port RAM (DPRAM) contains on-chip address counters (one for each port) for the synchronous members of the product family. Besides the main x36 format, the right port allows bus matching (x18 or x9, user-selectable). An internal sub-counter provides the extra addresses required to sequence out the 36-bit word in 18-bit or 9-bit increments. The sub-counter counts up in the “Little Endian” mode, and counts down if the user has chosen the “Big Endian” mode. The address counter is required to be in increment mode in order for the sub-counter to sequence out the second word (in x18 mode) or the remaining three bytes (in x9 mode).

For a x36 format (the only active format on the left port), each address counter in the CY7C09579V uses addresses (A₀₋₁₄).

For the right port (allowing for the bus-matching feature), a maximum of two address bits (out of a 2-bit sub-counter) are added.

1. $\overline{ADS}_{L/R}$ (pin #23/86) is a port's address strobe, allowing the loading of that port's burst counters if the corresponding $\overline{CNTEN}_{L/R}$ pin is active as well.
2. $\overline{CNTEN}_{L/R}$ (pin #25/84) is a port's count enable, provided to stall the operation of the address input and utilize the internal address generated by the internal counter for fast interleaved memory applications; when asserted, the address counter will increment on each positive transition of that port's clock signal.
3. $\overline{CNTRST}_{L/R}$ (pin #24/85) is a port's burst counter reset.

A new read-back (Hold+Read Mode) feature has been added, which is different between the left and right port due to the bus matching feature provided only for the right port. In read-back mode the internal address of the counter will be read from the data I/Os as shown in Figure 1.

Figure 1. Counter Operation Diagram

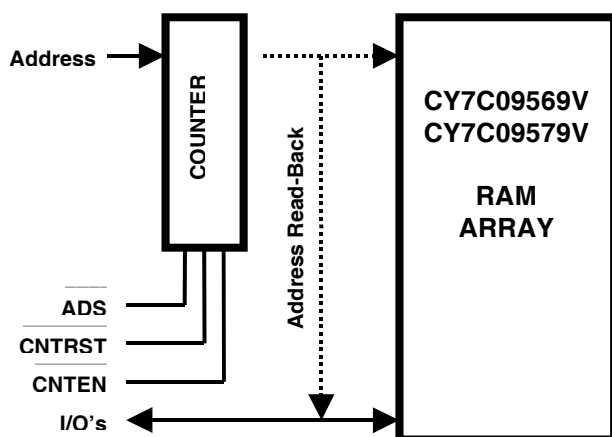

Note

82. Even though a logic level applied to a “Don't Care” input will not change the logical operation of the dual-port, inputs that are temporarily a “Don't Care” (along with unused inputs) must not be allowed to float. They must be forced either HIGH or LOW.

Bus Match Operation

The right port of the CY7C09569V/09579V 16K/32Kx36 dual-port SRAM can be configured in a 36-bit long-word, 18-bit word, or 9-bit byte format for data I/O. The data lines are divided into four lanes, each consisting of 9 bits (byte-size data lines).

Figure 2. Bus Match Operation Diagram

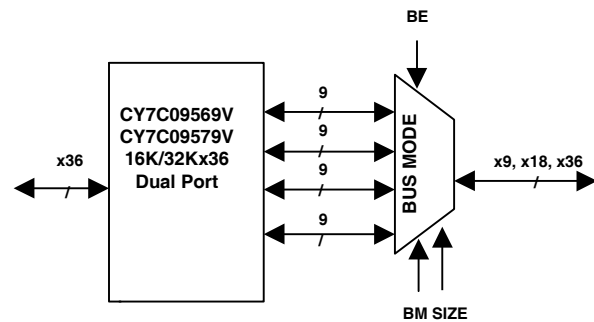

The Bus Match Select (BM) pin works with Bus Size Select (SIZE) and Big Endian Select (BE) to select the bus width (long-word, word, or byte) and data sequencing arrangement for the right port of the dual-port device. A logic “0” applied to both the Bus Match Select (BM) pin and to the Bus Size Select (SIZE) pin will select long-word (36-bit) operation. A logic “1” level applied to the Bus Match Select (BM) pin will enable whether byte or word bus width operation on the right port I/Os depending on the logic level applied to the SIZE pin. The level of Bus Match Select (BM) must be static throughout normal device operation.

The Bus Size Select (SIZE) pin selects either a byte or word data arrangement on the right port when the Bus Match Select (BM) pin is HIGH. A logic “1” on the SIZE pin when the BM pin is HIGH selects a byte bus (9-bit) data arrangement. A logic “0” on the SIZE pin when the BM pin is HIGH selects a word bus (18-bit) data arrangement. The level of the Bus Size Select (SIZE) must also be static throughout normal device operation.

The Big Endian Select (BE) pin is a multiple-function pin during word or byte bus selection (BM = 1). BE is used in Big Endian Select mode to determine the order by which bytes (or words) of data are transferred through the right data port. A logic “0” on the BE pin will select Little Endian data sequencing arrangement and a logic “1” on the BE pin will select a Big Endian data sequencing arrangement. Under these circumstances, the level on the BE pin should be static throughout dual-port operation.

Long-Word (36-bit) Operation

Bus Match Select (BM) and Bus Size Select (SIZE) set to a logic “0” will enable standard cycle long-word (36-bit) operation. In this mode, the right port's I/O operates essentially in an identical fashion to the left port of the dual-port SRAM. However no Byte Select control is available. All 36 bits of the long-word are shifted into and out of the right port's I/O buffer stages. All read and write timing parameters may be identical with respect to the two data ports. When the right port is configured for a long-word size, Big-Endian Select (BE) pin has no application and their inputs are “Don't Care”^[82] for the external user.

Word (18-bit) Operation

Word (18-bit) bus sizing operation is enabled when Bus Match Select (BM) is set to a logic "1" and the Bus Size Select (SIZE) pin is set to a logic "0." In this mode, 18 bits of data are ported through I/O_{0R-17R}. The level applied to the Big Endian (BE) pin determines the right port data I/O sequencing order (Big Endian or Little Endian).

During word (18-bit) bus size operation, a logic LOW applied to the BE pin will select Little Endian operation. In this case, the least significant data word is read from the right port first or written to the right port first. A logic "1" on the BE pin during word (18-bit) bus size operation will select Big Endian operation resulting in the most significant data word being transferred through the right port first. Internally, the data will be stored in the appropriate 36-bit LSB or MSB I/O memory location. Device operation requires a minimum of two clock cycles to read or write during word (18-bit) bus size operation. An internal sub-counter automatically increments the right port multiplexer control when Little or Big Endian operation is in effect.

Byte (9-bit) Operation

Byte (9-bit) bus sizing operation is enabled when Bus Match Select (BM) is set to a logic "1" and the Bus Size Select (SIZE) pin is set to a logic "1." In this mode, 9 bits of data are ported through I/O_{0R-8R}.

Big Endian and Little Endian data sequencing is available for dual-port operation. The level applied to the Big Endian pin (BE) under these circumstances will determine the right port data I/O sequencing order (Big or Little Endian). A logic LOW applied to the BE pin during byte (9-bit) bus size operation will select Little Endian operation. In this case, the least significant data byte is read from the right port first or written to the right port first. A logic "1" on the BE pin during byte (9-bit) bus size operation will select Big Endian operation resulting in the most significant data word to be transferred through the right port first. Internally, the data will be stored in the appropriate 36-bit LSB or MSB I/O memory location. Device operation requires a minimum of four clock cycles to read or write during byte (9-bit) bus size operation. An internal sub-counter automatically increments the right port multiplexer control when Little or Big Endian operation is in effect. When transferring data in byte (9-bit) bus match format, the unused I/O pins (I/O_{9RQ-35R}) are three-stated.

Ordering Information

16K × 36 3.3 V Synchronous Dual-Port SRAM

Speed (MHz)	Ordering Code	Package Name	Package Type	Operating Range
100	CY7C09569V-100AXC	A144	144-pin Pb-free Thin Quad Flat Pack	Commercial
	CY7C09569V-100BBC	BB172	172-ball Ball Grid Array (BGA)	

32K × 36 3.3 V Synchronous Dual-Port SRAM

Speed (MHz)	Ordering Code	Package Name	Package Type	Operating Range
100	CY7C09579V-100AC	A144	144-pin Thin Quad Flat Pack	Commercial
	CY7C09579V-100AXC	A144	144-pin Pb-free Thin Quad Flat Pack	
	CY7C09579V-100BBC	BB172	172-ball Ball Grid Array (BGA)	
83	CY7C09579V-83AC	A144	144-pin Thin Quad Flat Pack	Commercial
	CY7C09579V-83AXC	A144	144-pin Pb-free Thin Quad Flat Pack	
	CY7C09579V-83BBC	BB172	172-ball Ball Grid Array (BGA)	

Ordering Code Definitions

CY 7C 09 5 X9 V - XXX X X X

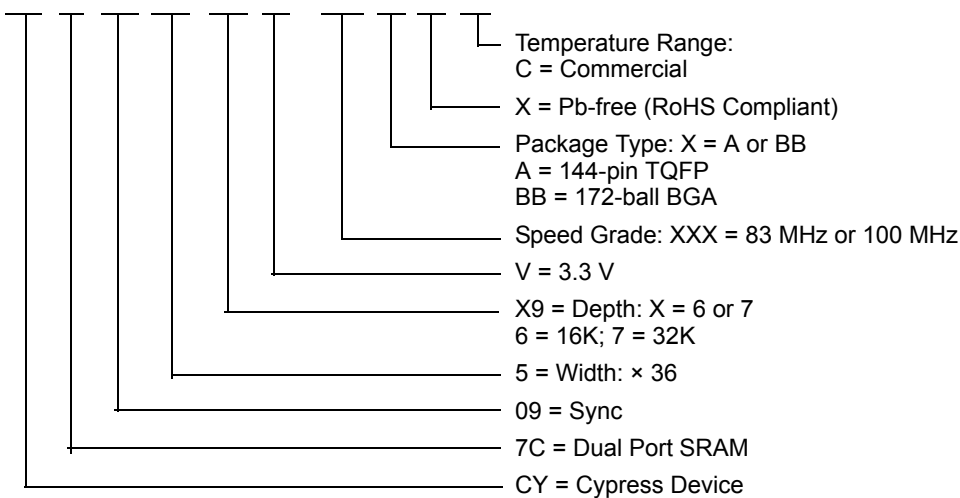

Package Diagrams

Figure 3. 144-pin TQFP (20 × 20 × 1.4 mm)

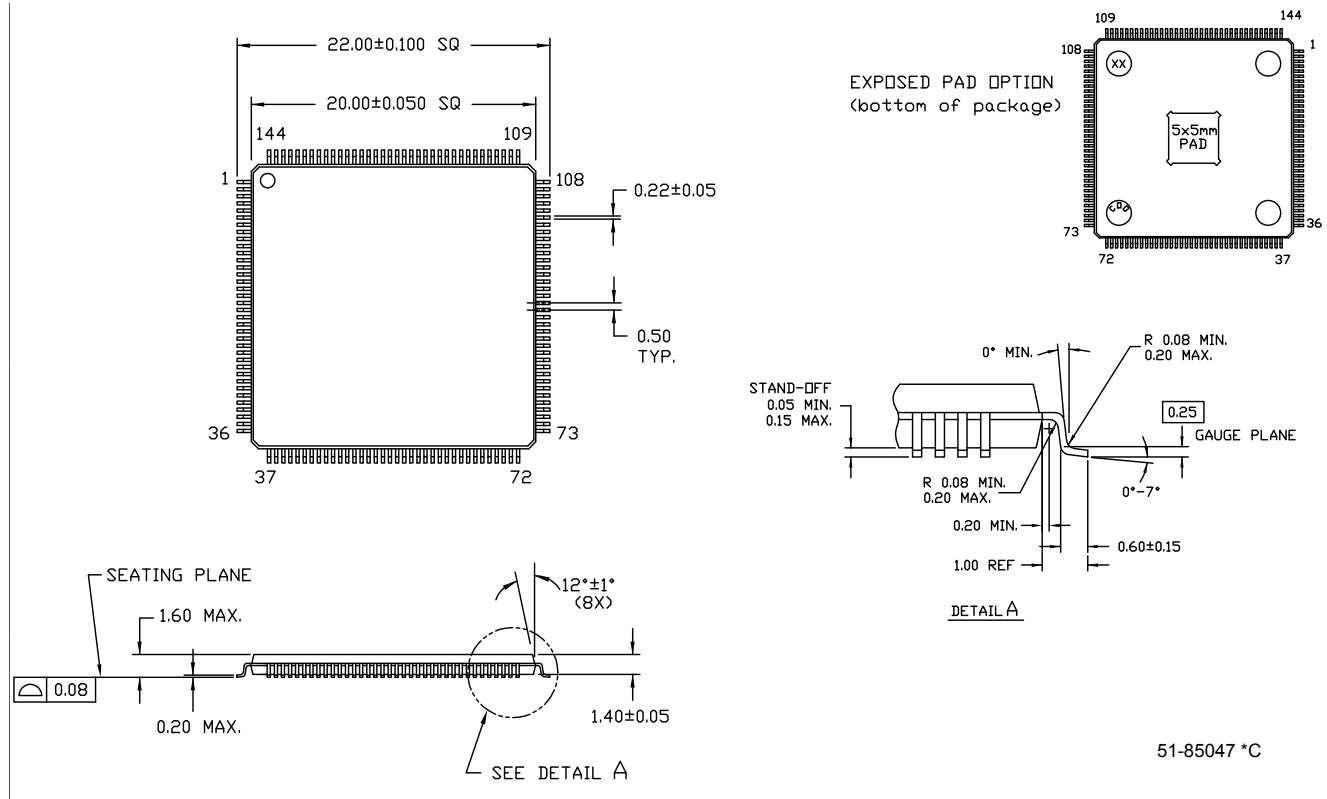
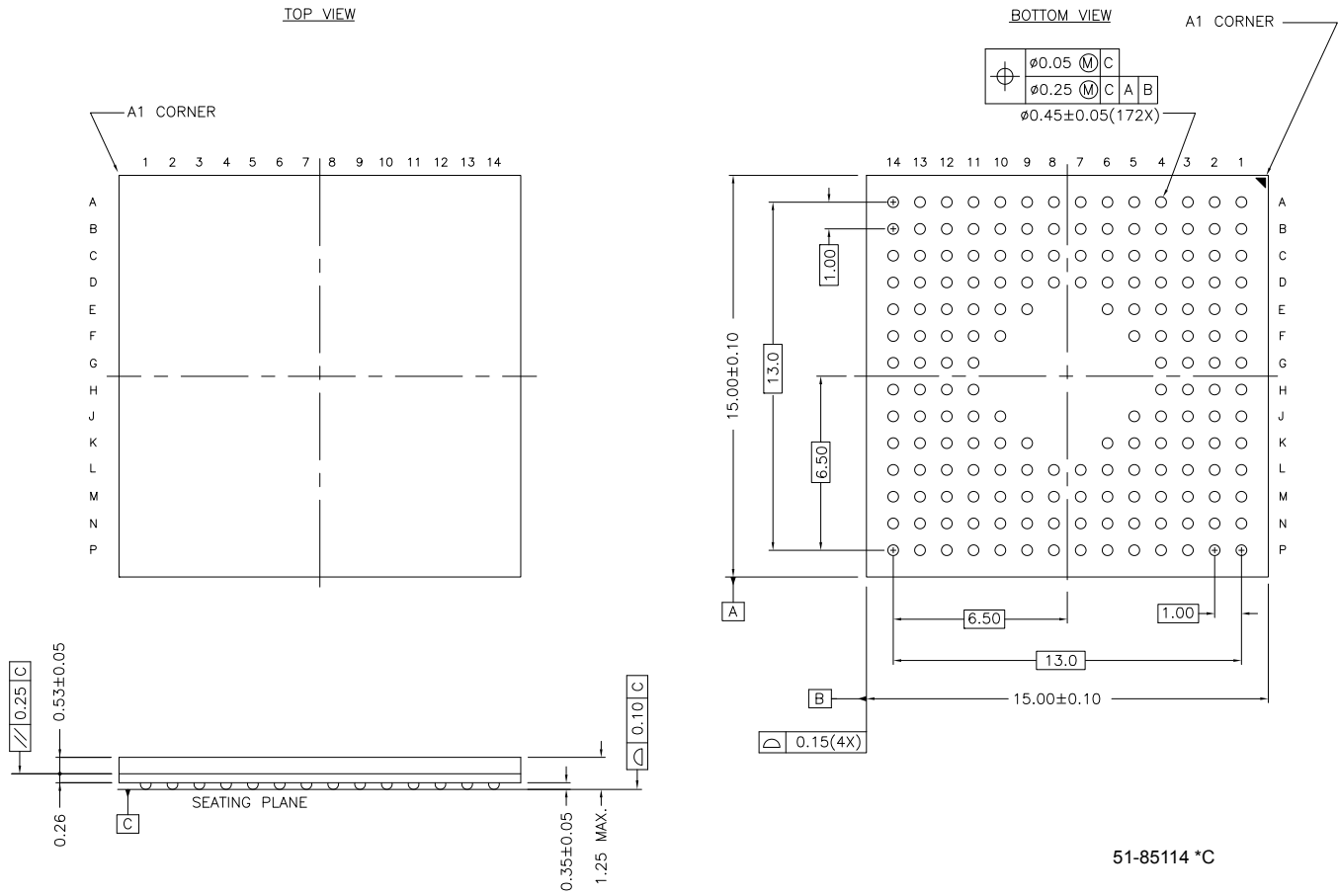

Figure 4. 172-ball FBGA (15 × 15 × 1.25 mm)



Document History Page

Document Title: CY7C09569V/CY7C09579V 3.3 V 16 K/32 K × 36 FLEx36™ Synchronous Dual-Port Static RAM Document Number: 38-06054				
REV.	ECN NO.	Issue Date	Orig. of Change	Description of Change
**	110213	12/16/01	SZV	Change from Spec number: 38-00743 to 38-06054
*A	122304	12/27/02	RBI	Power up requirements added to Maximum Ratings Information
*B	349775	See ECN	RUY	Added Pb-Free Information
*C	2897215	03/22/10	RAME	Removed inactive parts from ordering information. Updated package diagrams.
*D	3110406	12/14/2010	ADMU	Added Ordering Code Definitions . Minor edits and updated in new template.

Sales, Solutions, and Legal Information

Worldwide Sales and Design Support

Cypress maintains a worldwide network of offices, solution centers, manufacturer's representatives, and distributors. To find the office closest to you, visit us at [Cypress Locations](#).

Products

Automotive	cypress.com/go/automotive
Clocks & Buffers	cypress.com/go/clocks
Interface	cypress.com/go/interface
Lighting & Power Control	cypress.com/go/powerpsoc cypress.com/go/plc
Memory	cypress.com/go/memory
Optical & Image Sensing	cypress.com/go/image
PSoC	cypress.com/go/psoc
Touch Sensing	cypress.com/go/touch
USB Controllers	cypress.com/go/USB
Wireless/RF	cypress.com/go/wireless

PSoC Solutions

psoc.cypress.com/solutions
PSoC 1 | PSoC 3 | PSoC 5

© Cypress Semiconductor Corporation, 2001-2010. The information contained herein is subject to change without notice. Cypress Semiconductor Corporation assumes no responsibility for the use of any circuitry other than circuitry embodied in a Cypress product. Nor does it convey or imply any license under patent or other rights. Cypress products are not warranted nor intended to be used for medical, life support, life saving, critical control or safety applications, unless pursuant to an express written agreement with Cypress. Furthermore, Cypress does not authorize its products for use as critical components in life-support systems where a malfunction or failure may reasonably be expected to result in significant injury to the user. The inclusion of Cypress products in life-support systems application implies that the manufacturer assumes all risk of such use and in doing so indemnifies Cypress against all charges.

Any Source Code (software and/or firmware) is owned by Cypress Semiconductor Corporation (Cypress) and is protected by and subject to worldwide patent protection (United States and foreign), United States copyright laws and international treaty provisions. Cypress hereby grants to licensee a personal, non-exclusive, non-transferable license to copy, use, modify, create derivative works of, and compile the Cypress Source Code and derivative works for the sole purpose of creating custom software and or firmware in support of licensee product to be used only in conjunction with a Cypress integrated circuit as specified in the applicable agreement. Any reproduction, modification, translation, compilation, or representation of this Source Code except as specified above is prohibited without the express written permission of Cypress.

Disclaimer: CYPRESS MAKES NO WARRANTY OF ANY KIND, EXPRESS OR IMPLIED, WITH REGARD TO THIS MATERIAL, INCLUDING, BUT NOT LIMITED TO, THE IMPLIED WARRANTIES OF MERCHANTABILITY AND FITNESS FOR A PARTICULAR PURPOSE. Cypress reserves the right to make changes without further notice to the materials described herein. Cypress does not assume any liability arising out of the application or use of any product or circuit described herein. Cypress does not authorize its products for use as critical components in life-support systems where a malfunction or failure may reasonably be expected to result in significant injury to the user. The inclusion of Cypress' product in a life-support systems application implies that the manufacturer assumes all risk of such use and in doing so indemnifies Cypress against all charges.

Use may be limited by and subject to the applicable Cypress software license agreement.