

**3.3V 16K/32K/64K x 16/18**  
**Synchronous Dual-Port Static RAM**

**Features**

- True dual-ported memory cells that allow simultaneous access of the same memory location
- Six flow through/pipelined devices:
  - 16K x 16/18 organization (CY7C09269V/369V)
  - 32K x 16/18 organization (CY7C09279V/379V)
  - 64K x 16/18 organization (CY7C09289V/389V)
- Three modes:
  - Flow through
  - Pipelined
  - Burst
- Pipelined output mode on both ports allows fast 100 MHz operation
- 0.35 micron CMOS for optimum speed and power
- High speed clock to data access: 6.5<sup>[1,2]</sup>, 7.5<sup>[2]</sup>, 9, 12 ns (max)
- 3.3V low operating power:
  - Active = 115 mA (typical)
  - Standby = 10 μA (typical)
- Fully synchronous interface for easier operation
- Burst counters increment addresses internally:
  - Shorten cycle times
  - Minimize bus noise
  - Supported in flow through and pipelined modes
- Dual chip enables easy depth expansion
- Upper and lower byte controls for bus matching
- Automatic power down
- Commercial and industrial temperature ranges
- Pb-Free 100-pin TQFP package available

**Logic Block Diagram**

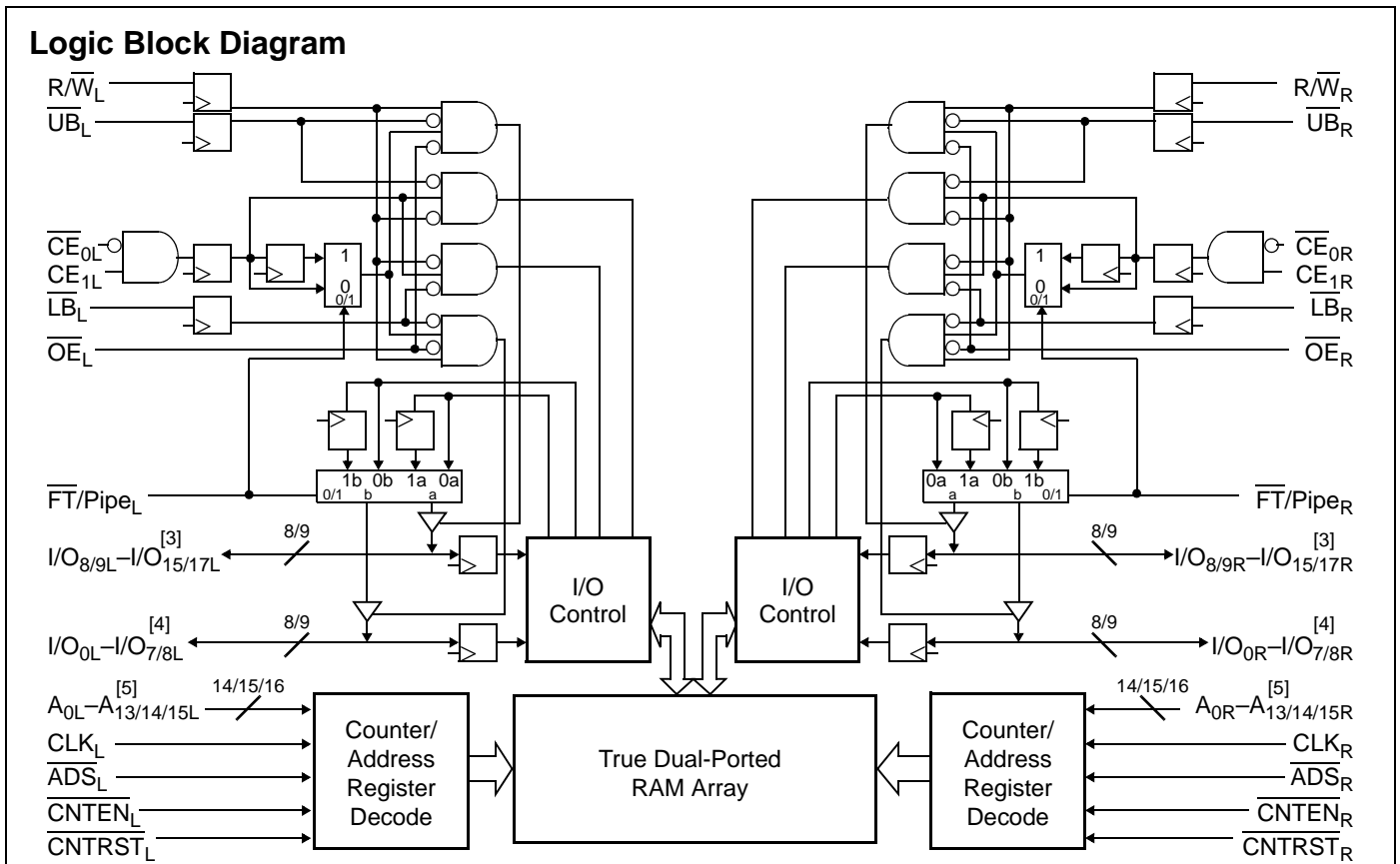

**Notes**

1. Call for availability.
2. See page 6 for Load Conditions.
3. I/O<sub>8</sub>-I/O<sub>15</sub> for x16 devices; I/O<sub>9</sub>-I/O<sub>17</sub> for x18 devices.
4. I/O<sub>0</sub>-I/O<sub>7</sub> for x16 devices. I/O<sub>0</sub>-I/O<sub>8</sub> for x18 devices.
5. A<sub>0</sub>-A<sub>13</sub> for 16K; A<sub>0</sub>-A<sub>14</sub> for 32K; A<sub>0</sub>-A<sub>15</sub> for 64K devices.

## Pinouts

**Figure 1. 100-Pin TQFP (Top View)**

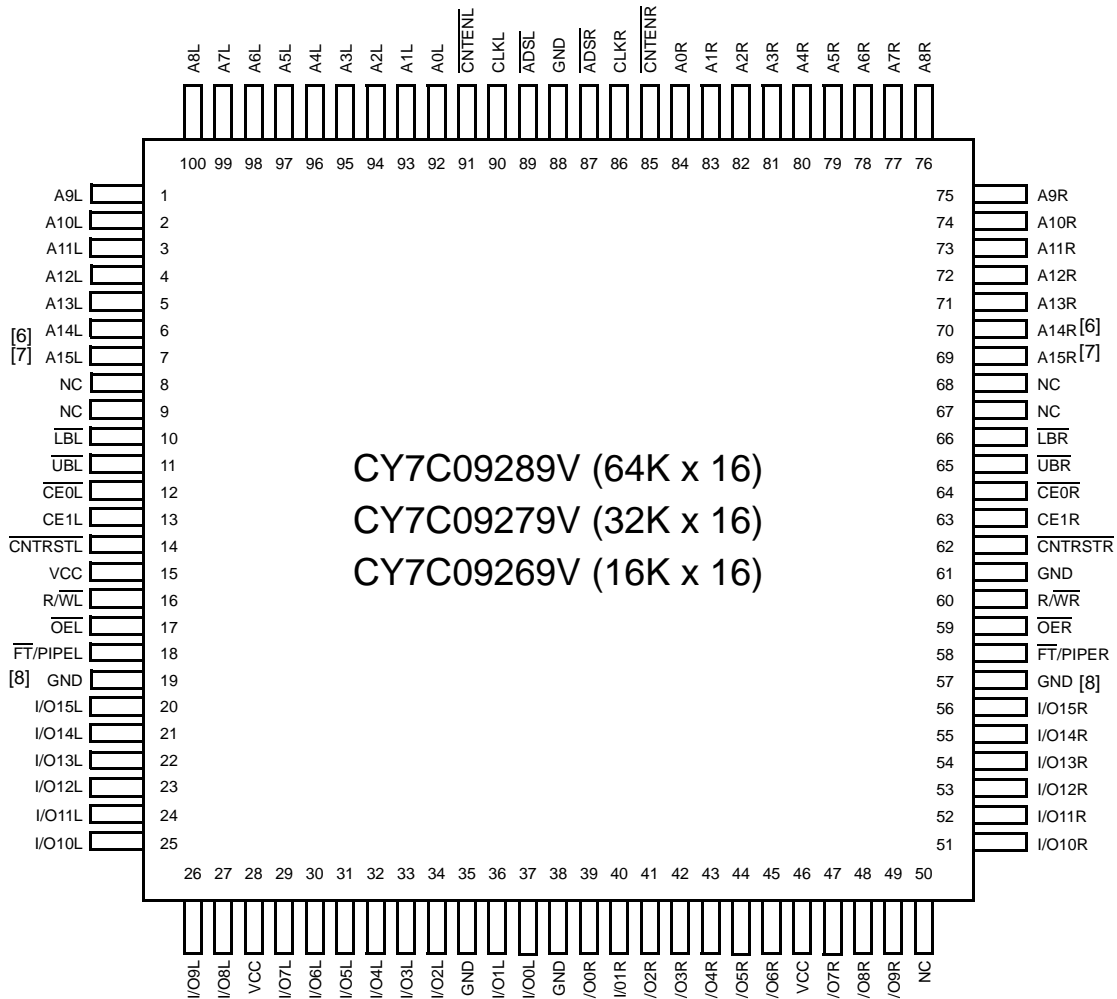

### Notes

6. This pin is NC for CY7C09269V.
7. This pin is NC for CY7C09269V and CY7C09279V.
8. For CY7C09269V and CY7C09279V, pin #18 connected to V<sub>CC</sub> is pin compatible to an IDT 5V x16 pipelined device; connecting pin #18 and #58 to GND is pin compatible to an IDT 5V x16 flow through device.

**Pinouts** (continued)

**Figure 2. 100-Pin TQFP (Top View)**

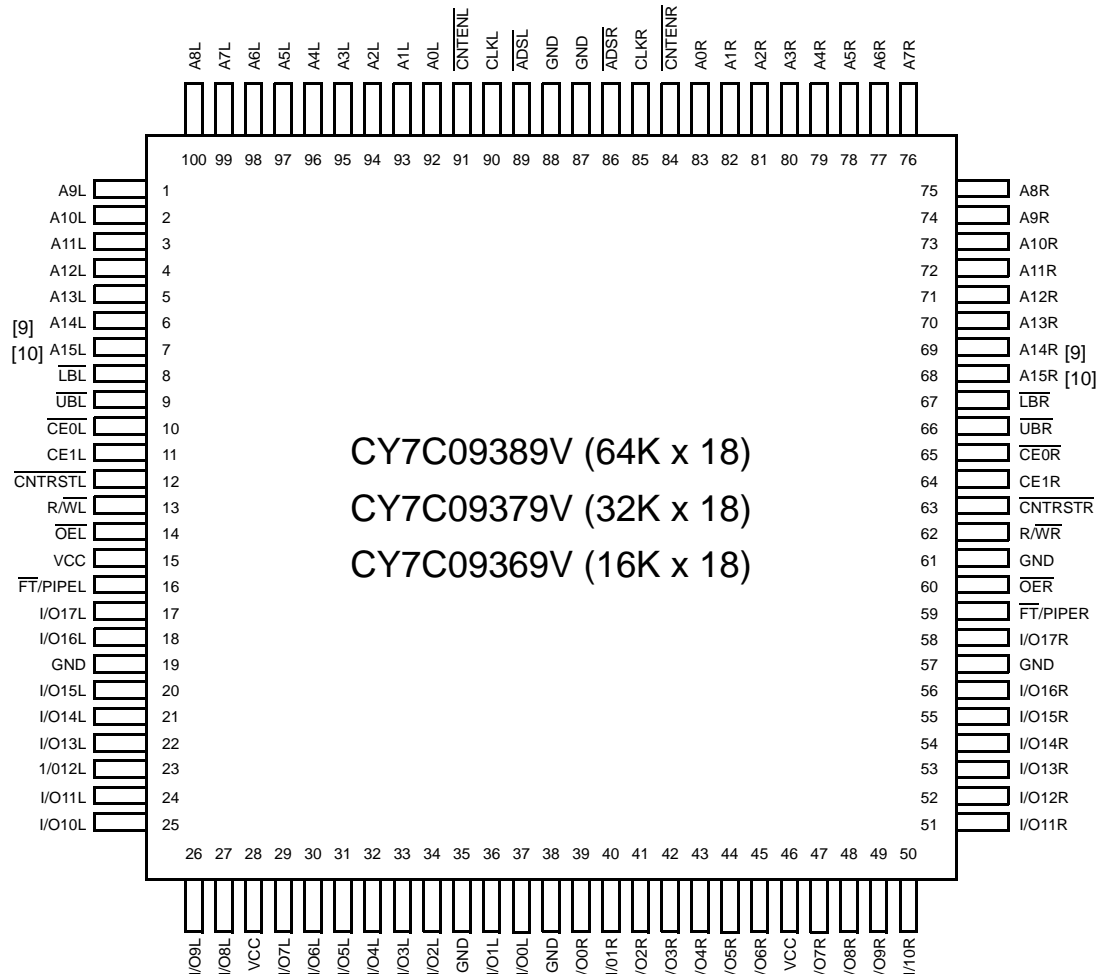

**Selection Guide**

Specifications	CY7C09269V/79V/89V CY7C09369V/79V/89V	CY7C09269V/79V/89V CY7C09369V/79V/89V	CY7C09269V/79V/89V CY7C09369V/79V/89V	CY7C09269V/79V/89V CY7C09369V/79V/89V
	<b>-6</b> <sup>[1, 2]</sup>	<b>-7</b> <sup>[2]</sup>	<b>-9</b>	<b>-12</b>
f <sub>MAX2</sub> (MHz) (Pipelined)	100	83	67	50
Max. Access Time (ns) (Clock to Data, Pipelined)	6.5	7.5	9	12
Typical Operating Current I <sub>CC</sub> (mA)	175	155	135	115
Typical Standby Current for I <sub>SB1</sub> (mA) (Both Ports TTL Level)	25	25	20	20
Typical Standby Current for I <sub>SB3</sub> (μA) (Both Ports CMOS Level)	10	10	10	10

**Notes**

- 9. This pin is NC for CY7C09369V.
- 10. This pin is NC for CY7C09369V and CY7C09379V.

## Pin Definitions

Left Port	Right Port	Description
A <sub>0L</sub> -A <sub>15L</sub>	A <sub>0R</sub> -A <sub>15R</sub>	<b>Address Inputs</b> (A <sub>0</sub> -A <sub>14</sub> for 32K, A <sub>0</sub> -A <sub>13</sub> for 16K devices).
ADS <sub>L</sub>	ADS <sub>R</sub>	<b>Address Strobe Input.</b> Used as an address qualifier. This signal must be asserted LOW to access the part using an externally supplied address. Asserting this signal LOW also loads the burst counter with the address present on the address pins.
CE <sub>0L</sub> , CE <sub>1L</sub>	CE <sub>0R</sub> , CE <sub>1R</sub>	<b>Chip Enable Input.</b> To select either the left or right port, both CE <sub>0</sub> AND CE <sub>1</sub> must be asserted to their active states (CE <sub>0</sub> ≤ V <sub>IL</sub> and CE <sub>1</sub> ≥ V <sub>IH</sub> ).
CLK <sub>L</sub>	CLK <sub>R</sub>	<b>Clock Signal.</b> This input can be free running or strobed. Maximum clock input rate is f <sub>MAX</sub> .
CNTEN <sub>L</sub>	CNTEN <sub>R</sub>	<b>Counter Enable Input.</b> Asserting this signal <u>LOW</u> increments the <u>burst address</u> counter of its respective port on each rising edge of CLK. CNTEN is disabled if ADS or CNTRST are asserted LOW.
CNTRST <sub>L</sub>	CNTRST <sub>R</sub>	<b>Counter Reset Input.</b> Asserting this signal <u>LOW</u> <u>resets</u> the <u>burst address</u> counter of its respective port to zero. CNTRST is not disabled by asserting ADS or CNTEN.
I/O <sub>0L</sub> -I/O <sub>17L</sub>	I/O <sub>0R</sub> -I/O <sub>17R</sub>	<b>Data Bus Input/Output</b> (I/O <sub>0</sub> -I/O <sub>15</sub> for x16 devices).
LB <sub>L</sub>	LB <sub>R</sub>	<b>Lower Byte Select Input.</b> Asserting this signal LOW enables read and write operations to the <u>lower byte</u> . (I/O <sub>0</sub> -I/O <sub>8</sub> for x18, I/O <sub>0</sub> -I/O <sub>7</sub> for x16) of the memory array. For read operations both the LB and OE signals must be asserted to drive output data on the lower byte of the data pins.
UB <sub>L</sub>	UB <sub>R</sub>	<b>Upper Byte Select Input.</b> Same function as LB, but to the upper byte (I/O <sub>8/9L</sub> -I/O <sub>15/17L</sub> ).
OE <sub>L</sub>	OE <sub>R</sub>	<b>Output Enable Input.</b> This signal must be asserted LOW to enable the I/O data pins during read operations.
R/W <sub>L</sub>	R/W <sub>R</sub>	<b>Read/Write Enable Input.</b> This signal is asserted LOW to write to the dual port memory array. For read operations, assert this pin HIGH.
FT/PIPE <sub>L</sub>	FT/PIPE <sub>R</sub>	<b>Flow Through/Pipelined Select Input.</b> For flow through mode operation, assert this pin LOW. For pipelined mode operation, assert this pin HIGH.
GND		<b>Ground Input.</b>
NC		<b>No Connect.</b>
V <sub>CC</sub>		<b>Power Input.</b>

## Functional Description

The CY7C09269V/79V/89V and CY7C09369V/79V/89V are high speed 3.3V synchronous CMOS 16K, 32K, and 64K x 16/18 dual-port static RAMs. Two ports are provided, permitting independent, simultaneous access for reads and writes to any location in memory<sup>[11]</sup>. Registers on control, address, and data lines allow for minimal setup and hold times. In pipelined output mode, data is registered for decreased cycle time. Clock to data valid t<sub>CD2</sub> = 6.5 ns<sup>[1, 2]</sup> (pipelined). Flow through mode can also be used to bypass the pipelined output register to eliminate access latency. In flow through mode, data is available t<sub>CD1</sub> = 18 ns after the address is clocked into the device. Pipelined output or flow through mode is selected through the FT/Pipe pin.

Each port contains a burst counter on the input address register. The internal write pulse width is independent of the LOW to HIGH transition of the clock signal. The internal write pulse is self timed to allow the shortest possible cycle times.

A HIGH on CE<sub>0</sub> or LOW on CE<sub>1</sub> for one clock cycle powers down the internal circuitry to reduce the static power consumption. The use of multiple Chip Enables enables easier banking of multiple chips for depth expansion configurations. In the pipelined mode, one cycle is required with CE<sub>0</sub> LOW and CE<sub>1</sub> HIGH to reactivate the outputs.

Counter enable inputs are provided to stall the operation of the address input and use the internal address generated by the internal counter for fast interleaved memory applications. A port's burst counter is loaded with the port's Address Strobe (ADS). When the port's Count Enable (CNTEN) is asserted, the address counter increments on each LOW to HIGH transition of that port's clock signal. This reads/writes one word from or into each successive address location, until CNTEN is deasserted. The counter can address the entire memory array and loop back to the start. Counter Reset (CNTRST) is used to reset the burst counter.

All parts are available in 100-pin Thin Quad Plastic Flatpack (TQFP) packages.

### Note

11. When writing simultaneously to the same location, the final value cannot be guaranteed.

## Maximum Ratings <sup>[12]</sup>

Exceeding maximum ratings may impair the useful life of the device. These user guidelines are not tested.

Storage Temperature ..... -65°C to +150°C  
 Ambient Temperature with  
 Power Applied..... -55°C to +125°C  
 Supply Voltage to Ground Potential ..... -0.5V to +4.6V  
 DC Voltage Applied to Outputs  
 in High Z State ..... -0.5V to  $V_{CC}+0.5V$

DC Input Voltage ..... -0.5V to  $V_{CC}+0.5V$   
 Output Current into Outputs (LOW)..... 20 mA  
 Static Discharge Voltage..... > 1100V  
 (per MIL-STD-883, Method 3015)  
 Latch up Current..... > 200 mA

## Operating Range

Range	Ambient Temperature	$V_{CC}$
Commercial	0°C to +70°C	3.3V ± 300 mV
Industrial	-40°C to +85°C	3.3V ± 300 mV

## Electrical Characteristics

Over the Operating Range

Parameter	Description	CY7C09269V/79V/89V CY7C09369V/79V/89V											Unit		
		-6 <sup>[1, 2]</sup>			-7 <sup>[2]</sup>			-9			-12				
		Min	Typ	Max	Min	Typ	Max	Min	Typ	Max	Min	Typ		Max	
$V_{OH}$	Output HIGH Voltage ( $V_{CC} = \text{Min}$ , $I_{OH} = -4.0 \text{ mA}$ )	2.4			2.4			2.4			2.4			V	
$V_{OL}$	Output LOW Voltage ( $V_{CC} = \text{Min}$ , $I_{OH} = +4.0 \text{ mA}$ )			0.4			0.4			0.4			0.4	V	
$V_{IH}$	Input HIGH Voltage	2.0			2.0			2.0			2.0			V	
$V_{IL}$	Input LOW Voltage			0.8			0.8			0.8			0.8	V	
$I_{OZ}$	Output Leakage Current	-10		10	-10		10	-10		10	-10		10	μA	
$I_{CC}$	Operating Current ( $V_{CC} = \text{Max}$ , $I_{OUT} = 0 \text{ mA}$ ) Outputs Disabled	Com'l.		175	320		155	275		135	230		115	180	mA
		Indust.					275	390		185	300				mA
$I_{SB1}$	Standby Current (Both Ports TTL Level) <sup>[13]</sup> $\overline{CE}_L \ \& \ \overline{CE}_R \geq V_{IH}$ , $f = f_{MAX}$	Com'l.		25	95		25	85		20	75		20	70	mA
		Indust.					85	120		35	85				mA
$I_{SB2}$	Standby Current (One Port TTL Level) <sup>[13]</sup> $\overline{CE}_L \   \ \overline{CE}_R \geq V_{IH}$ , $f = f_{MAX}$	Com'l.		115	175		105	165		95	155		85	140	mA
		Indust.					165	210		105	165				mA
$I_{SB3}$	Standby Current (Both Ports CMOS Level) <sup>[13]</sup> $\overline{CE}_L \ \& \ \overline{CE}_R \geq V_{CC} - 0.2V$ , $f = 0$	Com'l.		10	250		10	250		10	250		10	250	μA
		Indust.					10	250		10	250				μA
$I_{SB4}$	Standby Current (One Port CMOS Level) <sup>[13]</sup> $\overline{CE}_L \   \ \overline{CE}_R \geq V_{IH}$ , $f = f_{MAX}$	Com'l.		105	135		95	125		85	115		75	100	mA
		Indust.					125	170		95	125				mA

## Capacitance

Tested initially and after any design or process changes that may affect these parameters.

Parameter	Description	Test Conditions	Max	Unit
$C_{IN}$	Input Capacitance	$T_A = 25^\circ\text{C}$ , $f = 1 \text{ MHz}$ , $V_{CC} = 3.3V$	10	pF
$C_{OUT}$	Output Capacitance		10	pF

### Notes

12. The voltage on any input or I/O pin can not exceed the power pin during power up.

13.  $\overline{CE}_L$  and  $\overline{CE}_R$  are internal signals. To select either the left or right port, both  $\overline{CE}_0 \leq V_{IL}$  and  $CE_1 \geq V_{IH}$ .

Figure 3. AC Test Loads and Waveforms

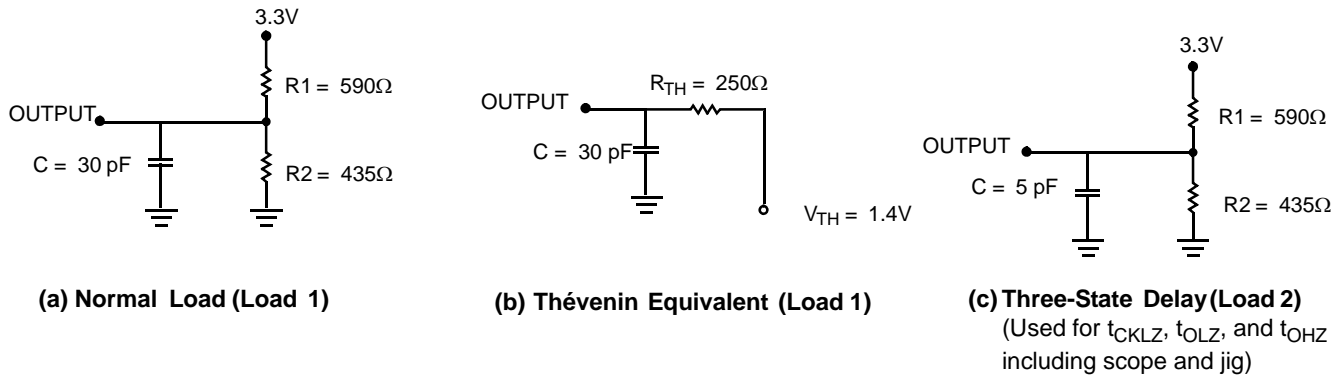
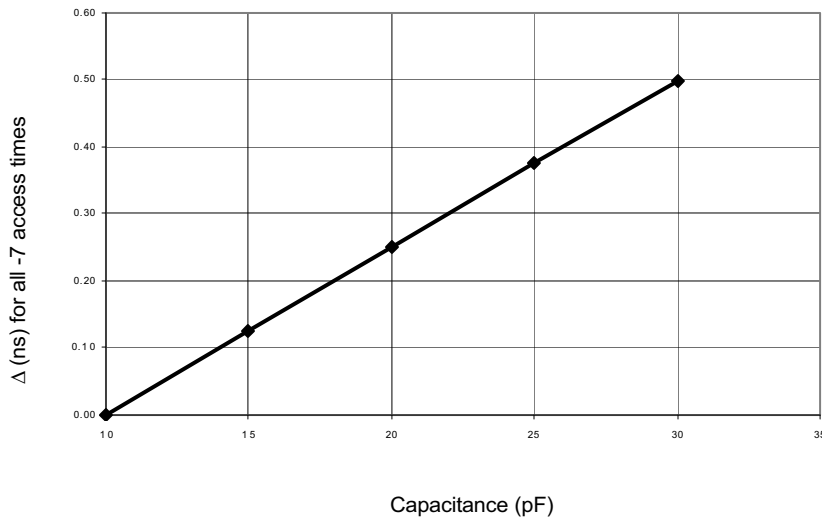

Figure 4. AC Test Loads (Applicable to -6 and -7 only) [14]



(b) Load Derating Curve

**Note**  
14. Test Conditions: C = 10 pF.

## Switching Characteristics

Over the Operating Range

Parameter	Description	CY7C09269V/79V/89V CY7C09369V/79V/89V								Unit
		-6 <sup>[1, 2]</sup>		-7 <sup>[2]</sup>		-9		-12		
		Min	Max	Min	Max	Min	Max	Min	Max	
f <sub>MAX1</sub>	f <sub>Max</sub> Flow Through		53		45		40		33	MHz
f <sub>MAX2</sub>	f <sub>Max</sub> Pipelined		100		83		67		50	MHz
t <sub>CYC1</sub>	Clock Cycle Time - Flow Through	19		22		25		30		ns
t <sub>CYC2</sub>	Clock Cycle Time - Pipelined	10		12		15		20		ns
t <sub>CH1</sub>	Clock HIGH Time - Flow Through	6.5		7.5		12		12		ns
t <sub>CL1</sub>	Clock LOW Time - Flow Through	6.5		7.5		12		12		ns
t <sub>CH2</sub>	Clock HIGH Time - Pipelined	4		5		6		8		ns
t <sub>CL2</sub>	Clock LOW Time - Pipelined	4		5		6		8		ns
t <sub>R</sub>	Clock Rise Time		3		3		3		3	ns
t <sub>F</sub>	Clock Fall Time		3		3		3		3	ns
t <sub>SA</sub>	Address Set-Up Time	3.5		4		4		4		ns
t <sub>HA</sub>	Address Hold Time	0		0		1		1		ns
t <sub>SC</sub>	Chip Enable Setup Time	3.5		4		4		4		ns
t <sub>HC</sub>	Chip Enable Hold Time	0		0		1		1		ns
t <sub>SW</sub>	R/W Set-Up Time	3.5		4		4		4		ns
t <sub>HW</sub>	R/W Hold Time	0		0		1		1		ns
t <sub>SD</sub>	Input Data Setup Time	3.5		4		4		4		ns
t <sub>HD</sub>	Input Data Hold Time	0		0		1		1		ns
t <sub>SAD</sub>	$\overline{\text{ADS}}$ Set-Up Time	3.5		4		4		4		ns
t <sub>HAD</sub>	$\overline{\text{ADS}}$ Hold Time	0		0		1		1		ns
t <sub>SCN</sub>	$\overline{\text{CNTEN}}$ Setup Time	3.5		4.5		5		5		ns
t <sub>HCN</sub>	$\overline{\text{CNTEN}}$ Hold Time	0		0		1		1		ns
t <sub>SRST</sub>	$\overline{\text{CNRST}}$ Setup Time	3.5		4		4		4		ns
t <sub>HRST</sub>	$\overline{\text{CNRST}}$ Hold Time	0		0		1		1		ns
t <sub>OE</sub>	Output Enable to Data Valid		8		9		10		12	ns
t <sub>OLZ</sub> <sup>[15,16]</sup>	$\overline{\text{OE}}$ to Low Z	2		2		2		2		ns
t <sub>OHZ</sub> <sup>[15,16]</sup>	$\overline{\text{OE}}$ to High Z	1	7	1	7	1	7	1	7	ns
t <sub>CD1</sub>	Clock to Data Valid - Flow Through		15		18		20		25	ns
t <sub>CD2</sub>	Clock to Data Valid - Pipelined		6.5		7.5		9		12	ns
t <sub>DC</sub>	Data Output Hold After Clock HIGH	2		2		2		2		ns
t <sub>CKZ</sub> <sup>[15,16]</sup>	Clock HIGH to Output High Z	2	9	2	9	2	9	2	9	ns
t <sub>CKZ</sub> <sup>[15,16]</sup>	Clock HIGH to Output Low Z	2		2		2		2		ns
<b>Port to Port Delays</b>										
t <sub>CWDD</sub>	Write Port Clock HIGH to Read Data Delay		30		35		40		40	ns
t <sub>CCS</sub>	Clock to Clock Setup Time		9		10		15		15	ns

### Notes

15. Test conditions used are Load 2.

16. This parameter is guaranteed by design, but it is not production tested.

## Switching Waveforms

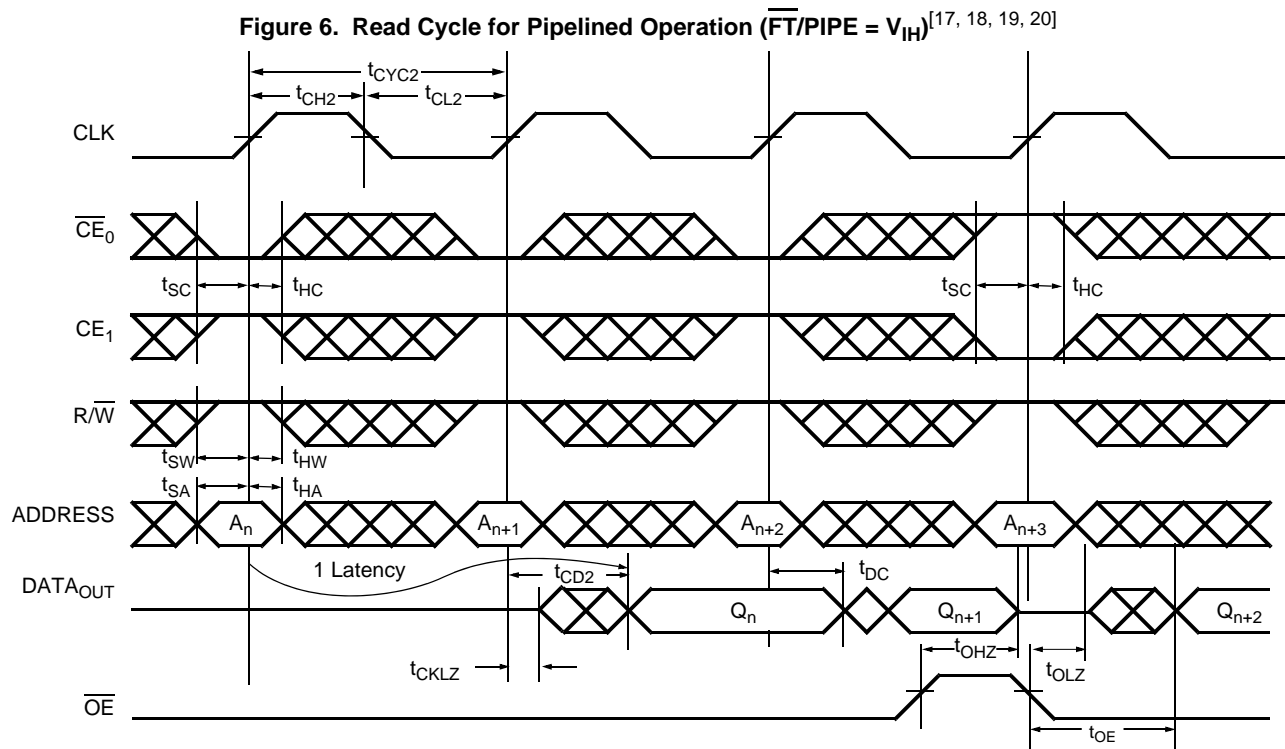
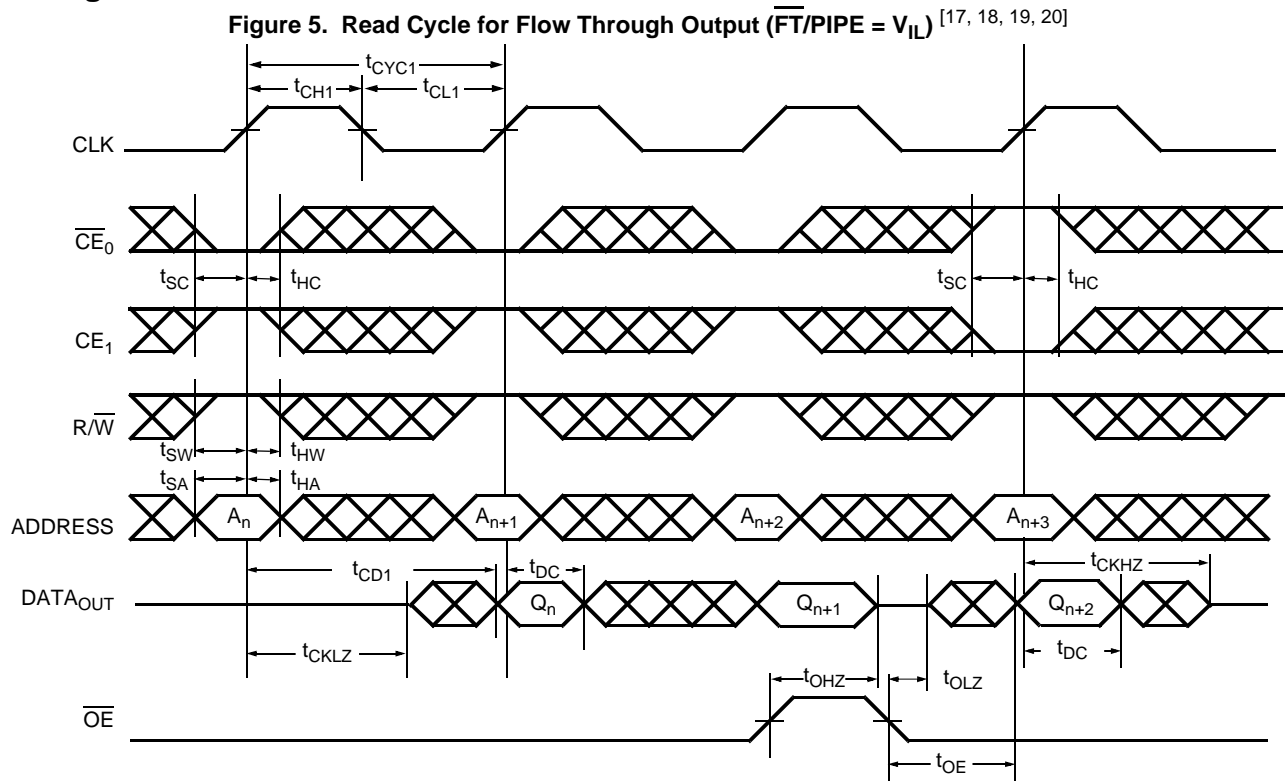

### Notes

17.  $\overline{\text{OE}}$  is asynchronously controlled; all other inputs are synchronous to the rising clock edge.
18.  $\text{ADS} = V_{\text{IL}}$ ,  $\text{CNTEN}$  and  $\text{CNTRST} = V_{\text{IH}}$ .
19. The output is disabled (high impedance state) by  $\overline{\text{CE}}_0 = V_{\text{IH}}$  or  $\text{CE}_1 = V_{\text{IL}}$  following the next rising edge of the clock.
20. Addresses do not have to be accessed sequentially since  $\text{ADS} = V_{\text{IL}}$  constantly loads the address on the rising edge of the CLK. Numbers are for reference only.



Switching Waveforms (continued)

Figure 7. Bank Select Pipelined Read<sup>[21, 22]</sup>

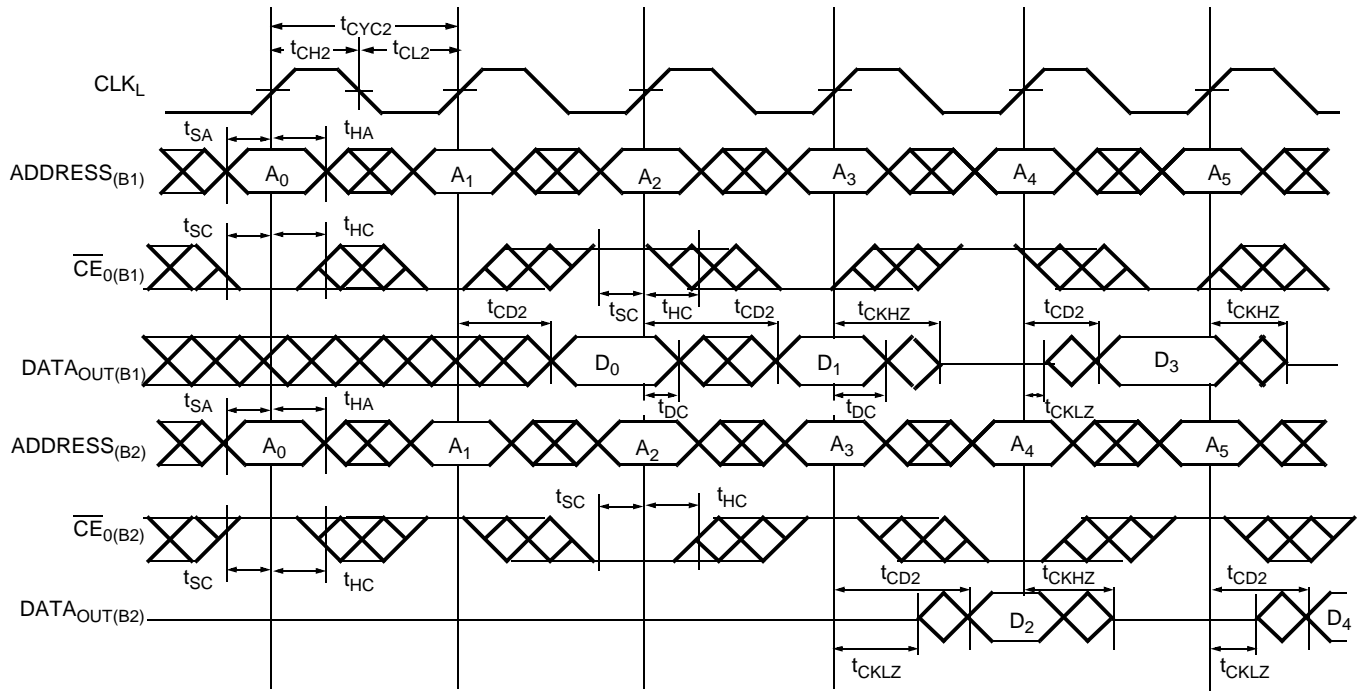
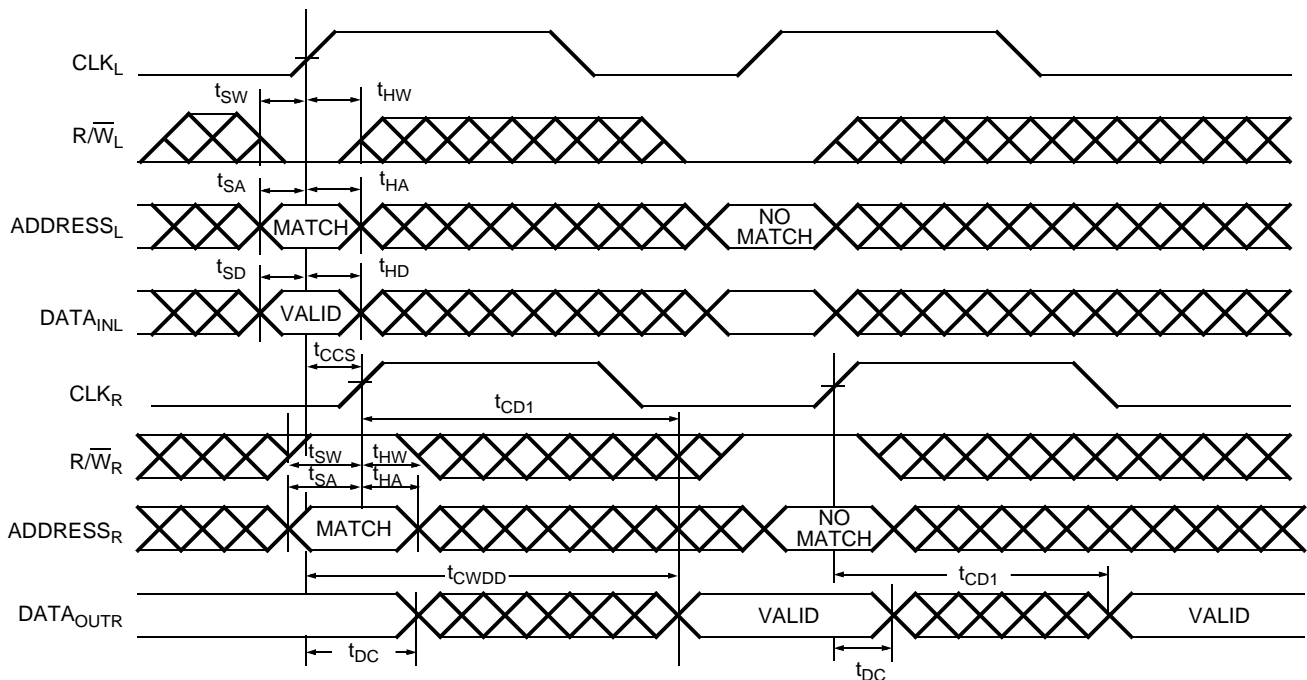

Figure 8. Left Port Write to Flow Through Right Port Read<sup>[23, 24, 25, 26]</sup>



Notes

21. In this depth expansion example, B1 represents Bank #1 and B2 is Bank #2; Each Bank consists of one Cypress dual-port device from this datasheet.
22.  $ADDRESS_{(B1)} = ADDRESS_{(B2)}$ .
23. The same waveforms apply for a right port write to flow through left port read.
24.  $CE_{0, UB, LB, and ADS} = V_{IL}$ ;  $CE_1, CNTEN, and CNTRST = V_{IH}$ .
25.  $OE = V_{IL}$  for the Right Port, which is being read from.  $OE = V_{IH}$  for the Left Port, which is being written to.
26. If  $t_{CCS} \leq$  maximum specified, then data from right port READ is not valid until the maximum specified for  $t_{CWDD}$ . If  $t_{CCS} >$  maximum specified, then data is not valid until  $t_{CCS} + t_{CD1} \cdot t_{CWDD}$  does not apply in this case.

Switching Waveforms (continued)

Figure 9. Pipelined Read-to-Write-to-Read ( $\overline{OE} = V_{IL}$ )<sup>[20, 27, 28, 29]</sup>

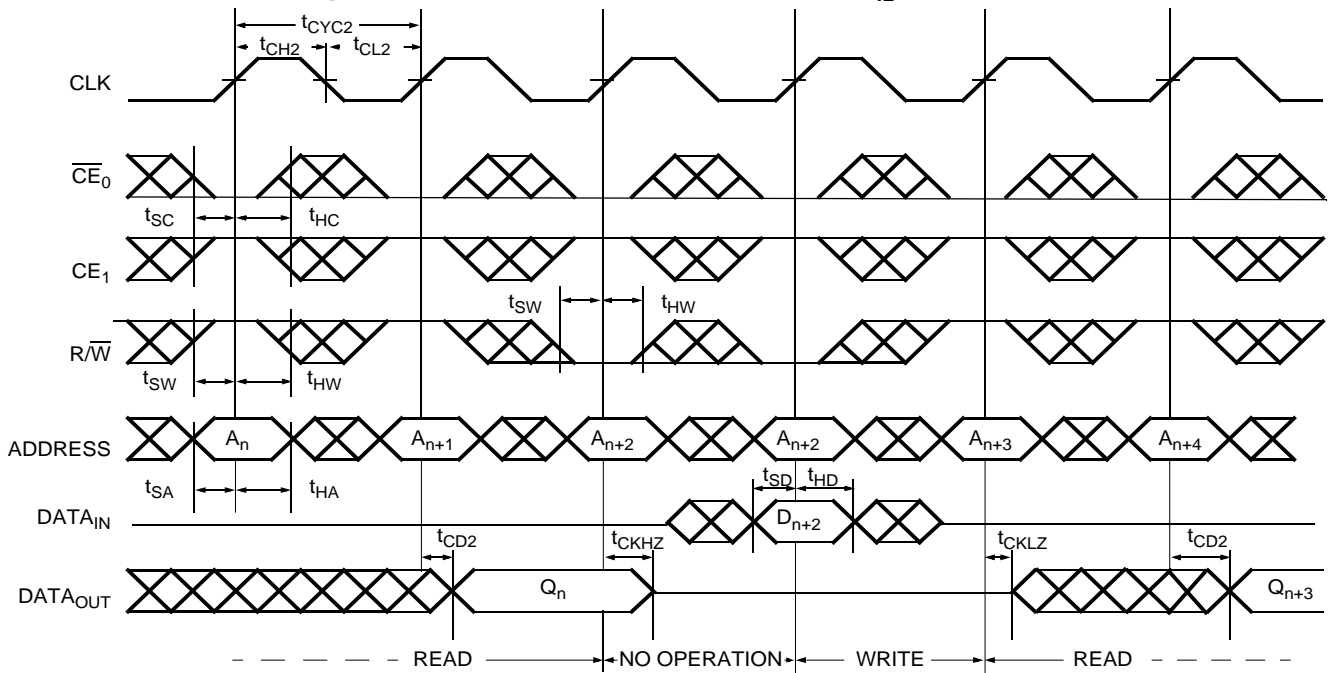
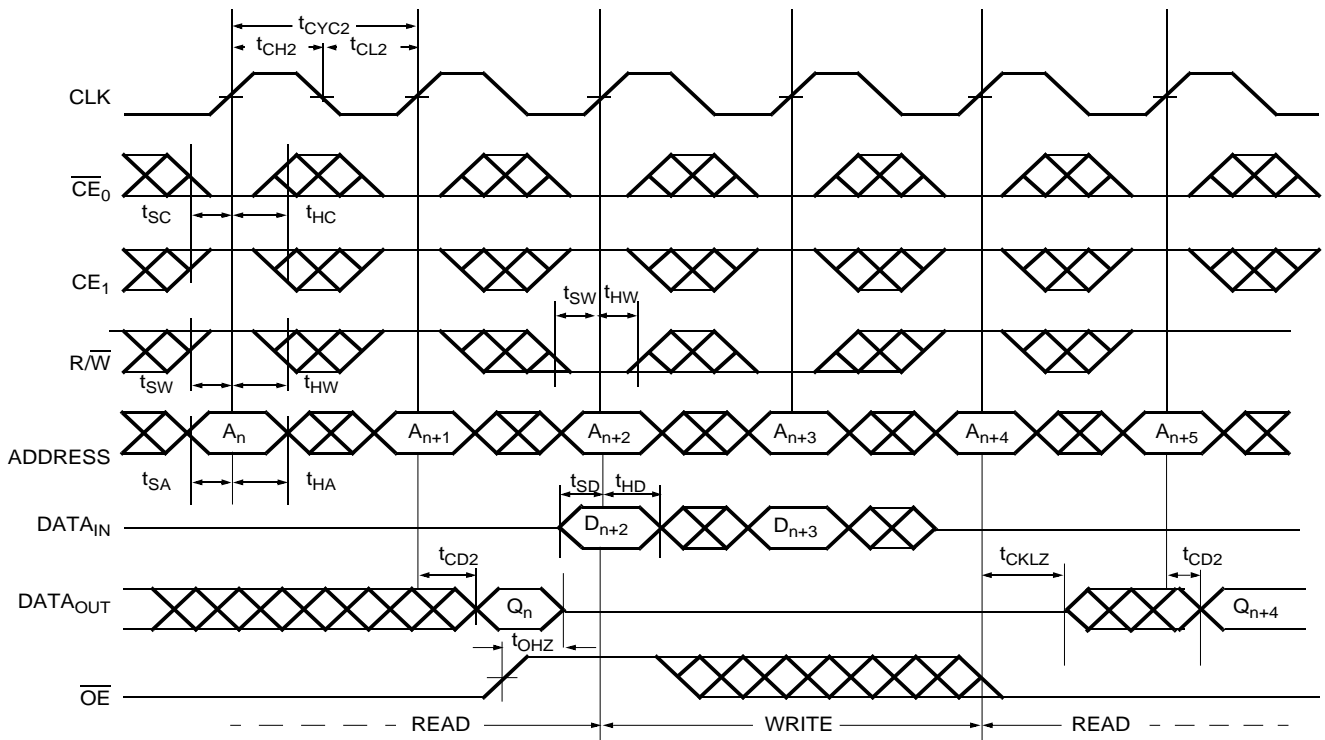

Figure 10. Pipelined Read-to-Write-to-Read ( $\overline{OE}$  Controlled)<sup>[20, 27, 28, 29]</sup>



Notes

- 27. Output state (High, LOW, or high impedance) is determined by the previous cycle control signals.
- 28.  $\overline{CE}_0$  and  $\overline{ADS} = V_{IL}$ ;  $\overline{CE}_1$ ,  $\overline{CNTEN}$ , and  $\overline{CNTRST} = V_{IH}$ .
- 29. During "No Operation", data in memory at the selected address may be corrupted and must be rewritten to ensure data integrity.

Switching Waveforms (continued)

Figure 11. Flow Through Read-to-Write-to-Read ( $\overline{OE} = V_{IL}$ )<sup>[18, 20, 28, 29]</sup>

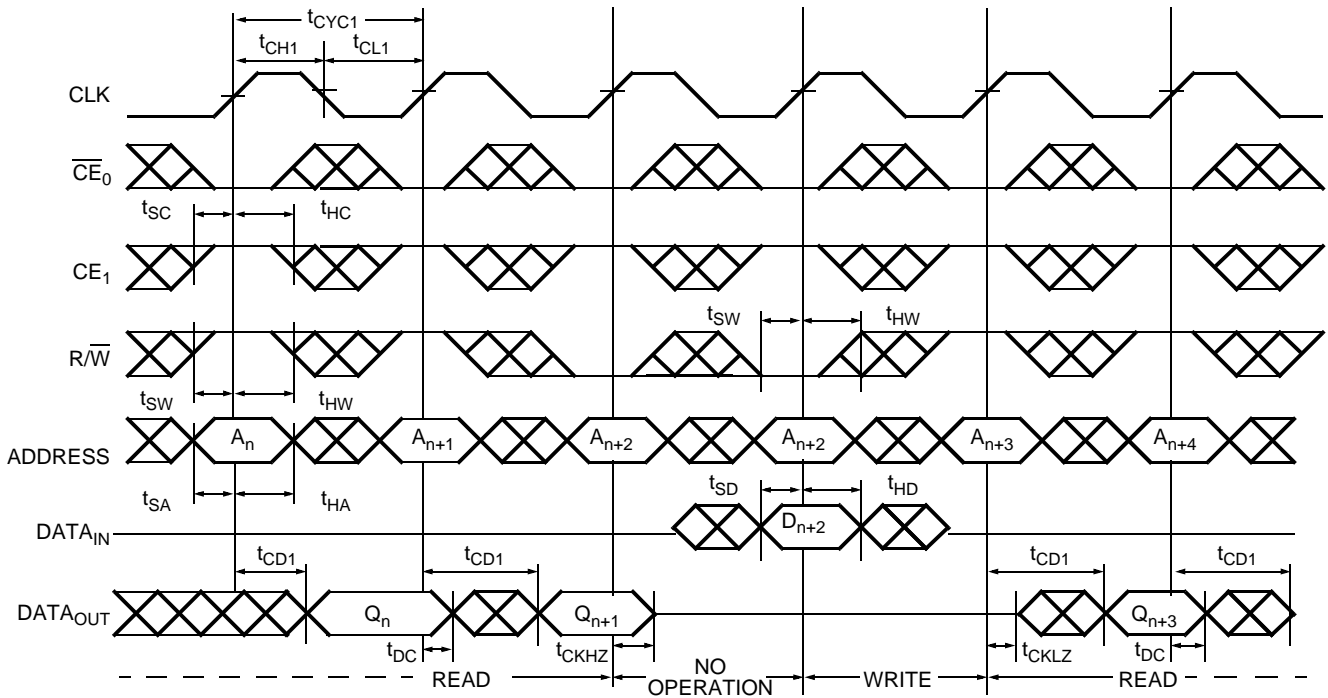
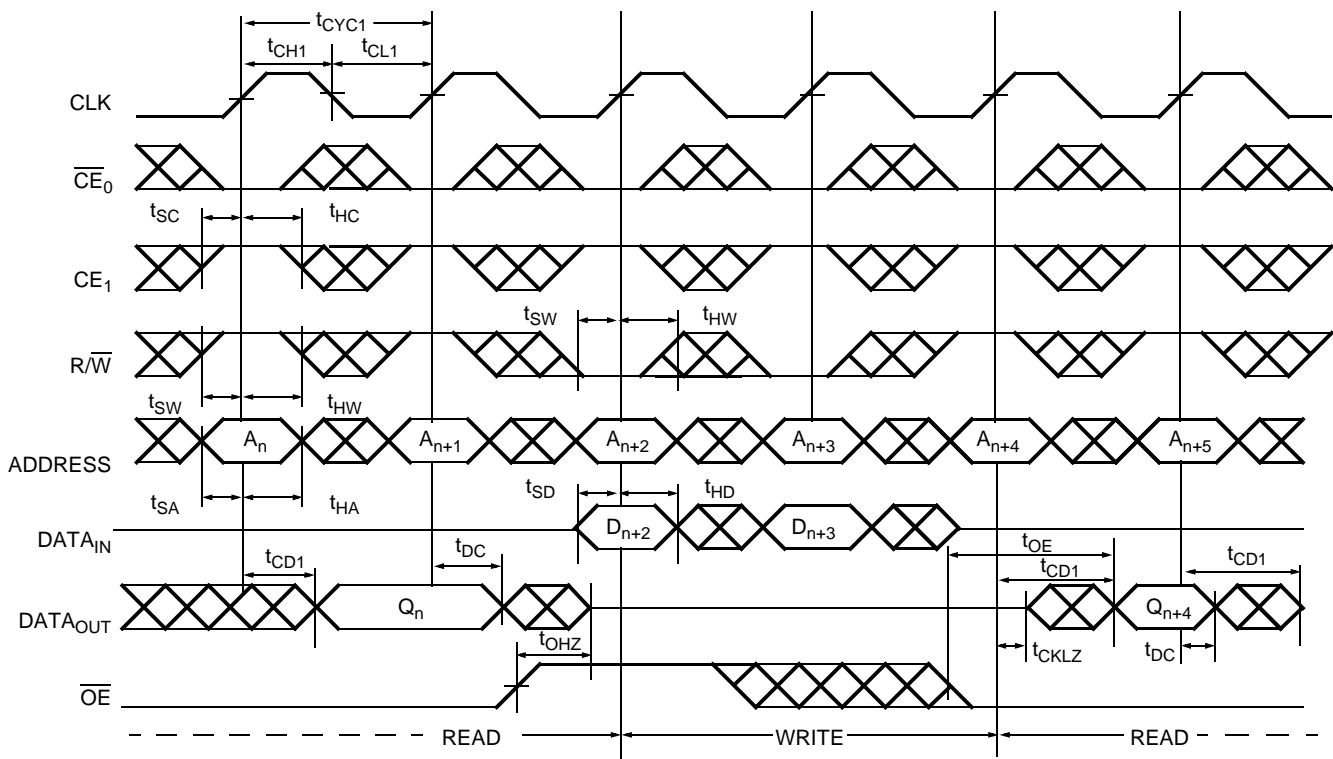

Figure 12. Flow Through Read-to-Write-to-Read ( $\overline{OE}$  Controlled)<sup>[18, 20, 27, 28, 29]</sup>



Switching Waveforms (continued)

Figure 13. Pipelined Read with Address Counter Advance<sup>[30]</sup>

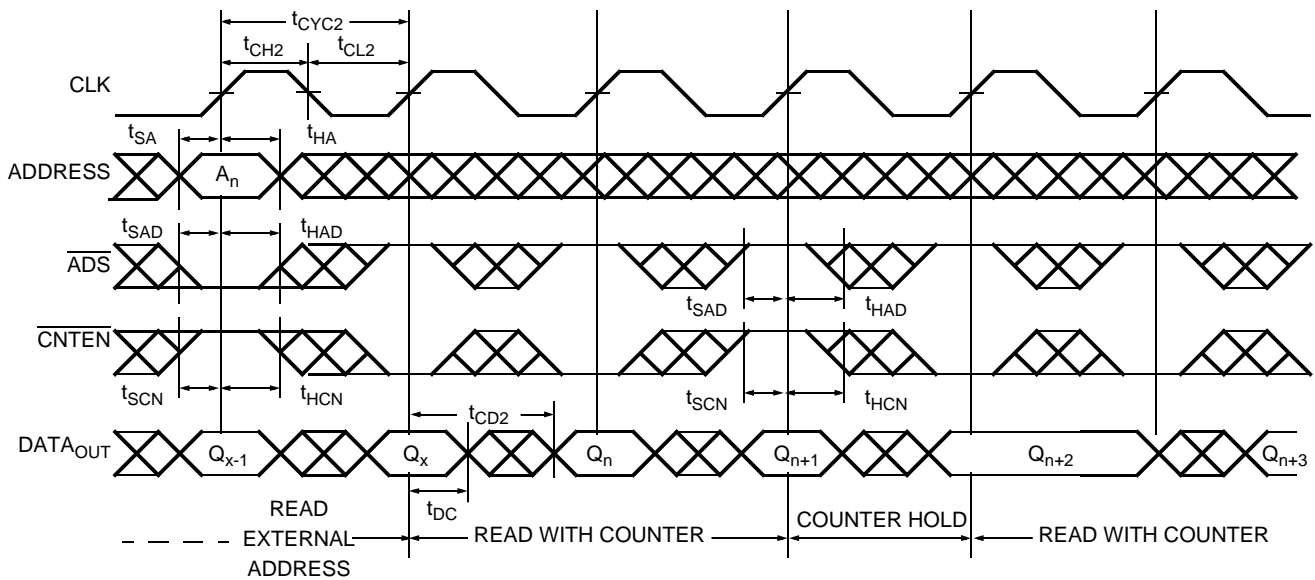
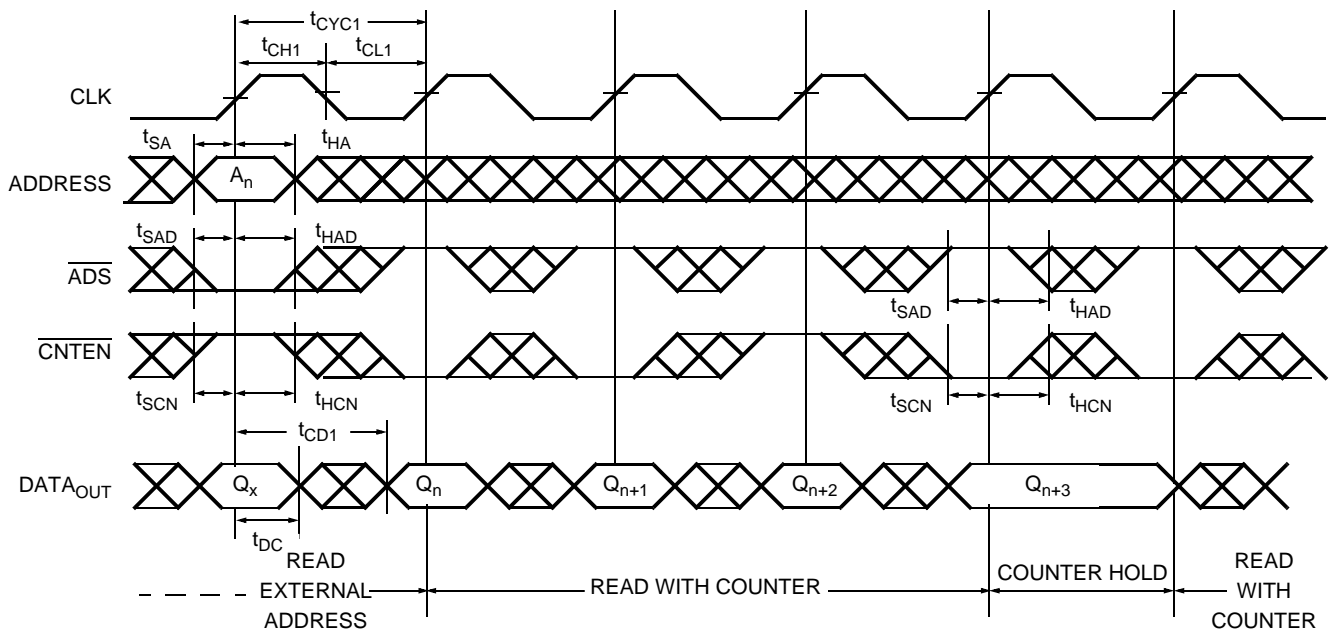

Figure 14. Flow Through Read with Address Counter Advance<sup>[30]</sup>



Note  
30.  $\overline{CE}_0$  and  $\overline{OE} = V_{IL}$ ;  $CE_1$ ,  $R/\overline{W}$  and  $\overline{CNTNST} = V_{IH}$ .

Switching Waveforms (continued)

Figure 15. Write with Address Counter Advance (Flow Through or Pipelined Outputs)<sup>[31, 32]</sup>

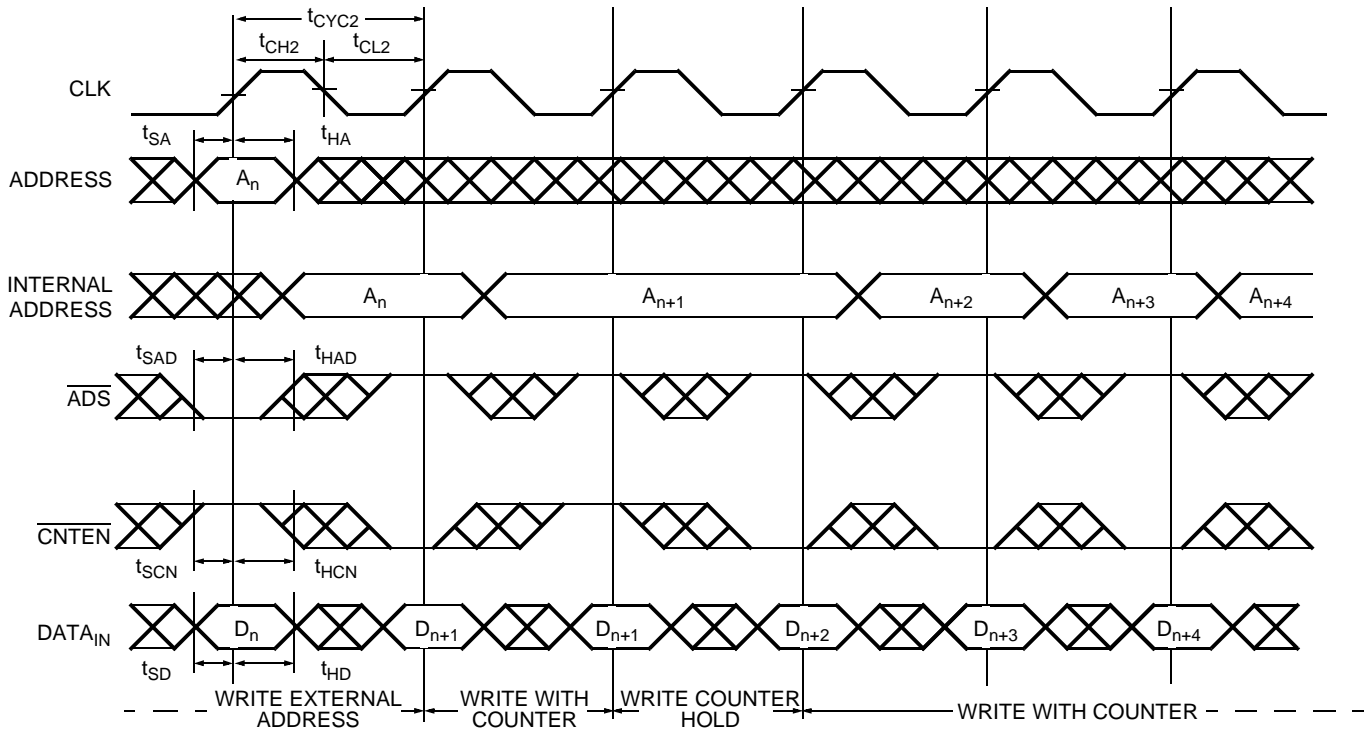

Notes

31.  $\overline{CE}_0, \overline{UB}, \overline{LB}$ , and  $R/\overline{W} = V_{IL}$ ;  $CE_1$  and  $\overline{CNTRST} = V_{IH}$ .

32. The "Internal Address" is equal to the "External Address" when  $\overline{ADS} = V_{IL}$  and equals the counter output when  $\overline{ADS} = V_{IH}$ .

Switching Waveforms (continued)

Figure 16. Counter Reset (Pipelined Outputs)<sup>[20, 27, 33, 34]</sup>

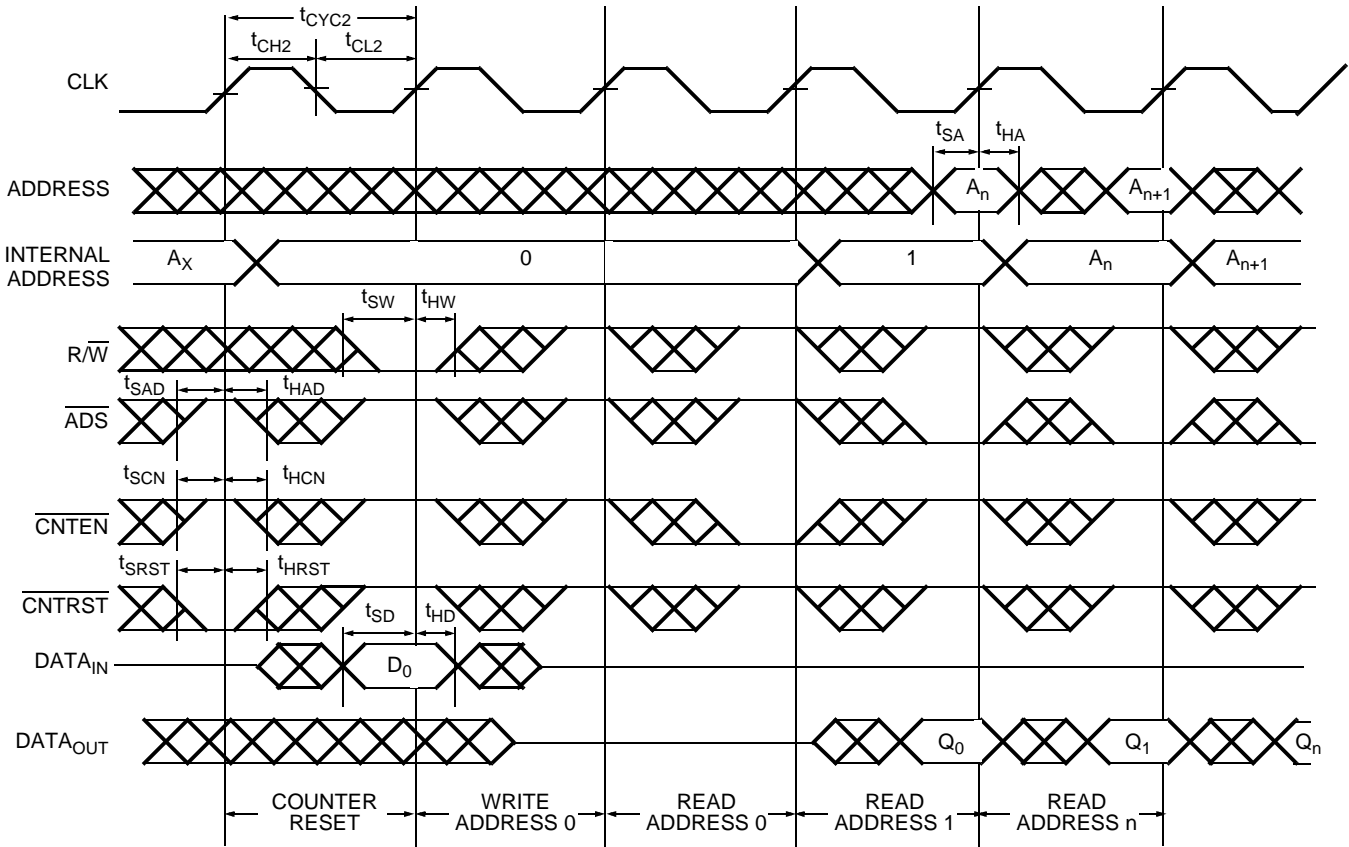





Notes





33.  $\overline{CE}_0$ ,  $\overline{UB}$ , and  $\overline{LB} = V_{IL}$ ;  $CE_1 = V_{IH}$ .

34. No dead cycle exists during counter reset. A READ or WRITE cycle may be coincidental with the counter reset.

### Read/Write and Enable Operation<sup>[35, 36, 37]</sup>

Inputs					Outputs	Operation
OE	CLK	CE <sub>0</sub>	CE <sub>1</sub>	R/W	I/O <sub>0</sub> –I/O <sub>17</sub>	
X		H	X	X	High-Z	Deselected <sup>[38]</sup>
X		X	L	X	High-Z	Deselected <sup>[38]</sup>
X		L	H	L	D <sub>IN</sub>	Write
L		L	H	H	D <sub>OUT</sub>	Read <sup>[35]</sup>
H	X	L	H	X	High-Z	Outputs Disabled

### Address Counter Control Operation<sup>[35, 39, 40, 41]</sup>

Address	Previous Address	CLK	ADS	CNTEN	CNTRST	I/O	Mode	Operation
X	X		X	X	L	D <sub>out(0)</sub>	Reset	Counter Reset to Address 0
A <sub>n</sub>	X		L	X	H	D <sub>out(n)</sub>	Load	Address Load into Counter
X	A <sub>n</sub>		H	H	H	D <sub>out(n)</sub>	Hold	External Address Blocked—Counter Disabled
X	A <sub>n</sub>		H	L	H	D <sub>out(n+1)</sub>	Increment	Counter Enabled—Internal Address Generation
X	A <sub>n</sub>		H	L	H	D <sub>out(n+1)</sub>	Increment	Counter Enabled—Internal Address Generation

#### Notes

35. "X" = "Don't Care", "H" = V<sub>IH</sub>, "L" = V<sub>IL</sub>.

36. ADS, CNTEN, CNTRST = "Don't Care".

37. OE is an asynchronous input signal.

38. When CE changes state in the pipelined mode, deselection and read happen in the following clock cycle.

39. CE<sub>0</sub> and OE = V<sub>IL</sub>; CE<sub>1</sub> and R/W = V<sub>IH</sub>.

40. Data shown for flow through mode; pipelined mode output is delayed by one cycle.

41. Counter operation is independent of CE<sub>0</sub> and CE<sub>1</sub>.

## Ordering Information

### 16K x16 3.3V Synchronous Dual-Port SRAM

Speed (ns)	Ordering Code	Package Diagram	Package Type	Operating Range
6.5 <sup>[1, 2]</sup>	CY7C09269V-6AC	51-85048	100-Pin Thin Quad Flat Pack	Commercial
	CY7C09269V-6AXC		100-Pin Thin Quad Flat Pack (Pb-Free)	
7.5 <sup>[2]</sup>	CY7C09269V-7AC	51-85048	100-Pin Thin Quad Flat Pack	Commercial
	CY7C09269V-7AXC		100-Pin Thin Quad Flat Pack (Pb-Free)	
9	CY7C09269V-9AC	51-85048	100-Pin Thin Quad Flat Pack	Commercial
	CY7C09269V-9AXC		100-Pin Thin Quad Flat Pack (Pb-Free)	
	CY7C09269V-9AI	51-85048	100-Pin Thin Quad Flat Pack	Industrial
12	CY7C09269V-12AC	51-85048	100-Pin Thin Quad Flat Pack	Commercial
	CY7C09269V-12AXC		100-Pin Thin Quad Flat Pack (Pb-Free)	

### 32K x16 3.3V Synchronous Dual-Port SRAM

Speed (ns)	Ordering Code	Package Diagram	Package Type	Operating Range
6.5 <sup>[1, 2]</sup>	CY7C09279V-6AC	51-85048	100-Pin Thin Quad Flat Pack	Commercial
	CY7C09279V-6AXC		100-Pin Thin Quad Flat Pack (Pb-Free)	
7.5 <sup>[2]</sup>	CY7C09279V-7AC	51-85048	100-Pin Thin Quad Flat Pack	Commercial
	CY7C09279V-7AXC		100-Pin Thin Quad Flat Pack (Pb-Free)	
9	CY7C09279V-9AC	51-85048	100-Pin Thin Quad Flat Pack	Commercial
	CY7C09279V-9AI	51-85048	100-Pin Thin Quad Flat Pack	Industrial
12	CY7C09279V-12AC	51-85048	100-Pin Thin Quad Flat Pack	Commercial
	CY7C09279V-12AXC		100-Pin Thin Quad Flat Pack (Pb-Free)	

### 64K x16 3.3V Synchronous Dual-Port SRAM

Speed (ns)	Ordering Code	Package Diagram	Package Type	Operating Range
6.5 <sup>[1, 2]</sup>	CY7C09289V-6AC	51-85048	100-Pin Thin Quad Flat Pack	Commercial
	CY7C09289V-6AXC		100-Pin Thin Quad Flat Pack (Pb-Free)	
7.5 <sup>[2]</sup>	CY7C09289V-7AC	51-85048	100-Pin Thin Quad Flat Pack	Commercial
	CY7C09289V-7AXC		100-Pin Thin Quad Flat Pack (Pb-Free)	
9	CY7C09289V-9AC	51-85048	100-Pin Thin Quad Flat Pack	Commercial
	CY7C09289V-9AXC		100-Pin Thin Quad Flat Pack (Pb-Free)	
	CY7C09289V-9AI	51-85048	100-Pin Thin Quad Flat Pack	Industrial
	CY7C09289V-9AXI		100-Pin Thin Quad Flat Pack (Pb-Free)	
12	CY7C09289V-12AC	51-85048	100-Pin Thin Quad Flat Pack	Commercial
	CY7C09289V-12AXC		100-Pin Thin Quad Flat Pack (Pb-Free)	



**Ordering Information** (Continued)

**16K x18 3.3V Synchronous Dual-Port SRAM**

Speed (ns)	Ordering Code	Package Diagram	Package Type	Operating Range
6.5 <sup>[1, 2]</sup>	CY7C09369V-6AC	51-85048	100-Pin Thin Quad Flat Pack	Commercial
	CY7C09369V-6AXC		100-Pin Thin Quad Flat Pack (Pb-Free)	
7.5 <sup>[2]</sup>	CY7C09369V-7AC	51-85048	100-Pin Thin Quad Flat Pack	Commercial
	CY7C09369V-7AXC		100-Pin Thin Quad Flat Pack (Pb-Free)	
	CY7C09369V-7AI	51-85048	100-Pin Thin Quad Flat Pack	Industrial
9	CY7C09369V-9AC	51-85048	100-Pin Thin Quad Flat Pack	Commercial
	CY7C09369V-9AXC		100-Pin Thin Quad Flat Pack (Pb-Free)	
	CY7C09369V-9AI	51-85048	100-Pin Thin Quad Flat Pack	Industrial
12	CY7C09369V-12AC	51-85048	100-Pin Thin Quad Flat Pack	Commercial
	CY7C09369V-12AXC		100-Pin Thin Quad Flat Pack (Pb-Free)	

**32K x18 3.3V Synchronous Dual-Port SRAM**

Speed (ns)	Ordering Code	Package Diagram	Package Type	Operating Range
6.5 <sup>[1, 2]</sup>	CY7C09379V-6AC	51-85048	100-Pin Thin Quad Flat Pack	Commercial
	CY7C09379V-6AXC		100-Pin Thin Quad Flat Pack (Pb-Free)	
7.5 <sup>[2]</sup>	CY7C09379V-7AC	51-85048	100-Pin Thin Quad Flat Pack	Commercial
9	CY7C09379V-9AC	51-85048	100-Pin Thin Quad Flat Pack	Commercial
	CY7C09379V-9AI	51-85048	100-Pin Thin Quad Flat Pack	Industrial
12	CY7C09379V-12AC	51-85048	100-Pin Thin Quad Flat Pack	Commercial
	CY7C09379V-12AXC		100-Pin Thin Quad Flat Pack (Pb-Free)	
	CY7C09379V-12AXCT		100-Pin Thin Quad Flat Pack (Pb-Free)	

**64K x18 3.3V Synchronous Dual-Port SRAM**

Speed (ns)	Ordering Code	Package Diagram	Package Type	Operating Range
6.5 <sup>[1, 2]</sup>	CY7C09389V-6AC	51-85048	100-Pin Thin Quad Flat Pack	Commercial
	CY7C09389V-6AXC		100-Pin Thin Quad Flat Pack (Pb-Free)	
7.5 <sup>[2]</sup>	CY7C09389V-7AC	51-85048	100-Pin Thin Quad Flat Pack	Commercial
	CY7C09389V-7AXC		100-Pin Thin Quad Flat Pack (Pb-Free)	
9	CY7C09389V-9AC	51-85048	100-Pin Thin Quad Flat Pack	Commercial
	CY7C09389V-9AXC		100-Pin Thin Quad Flat Pack (Pb-Free)	
	CY7C09389V-9AI	51-85048	100-Pin Thin Quad Flat Pack	Industrial
	CY7C09389V-9AXI		100-Pin Thin Quad Flat Pack (Pb-Free)	
12	CY7C09389V-12AC	51-85048	100-Pin Thin Quad Flat Pack	Commercial
	CY7C09389V-12AXC		100-Pin Thin Quad Flat Pack (Pb-Free)	

Package Diagrams

Figure 17. 100-Pin Thin Plastic Quad Flat Pack (TQFP), 51-85048

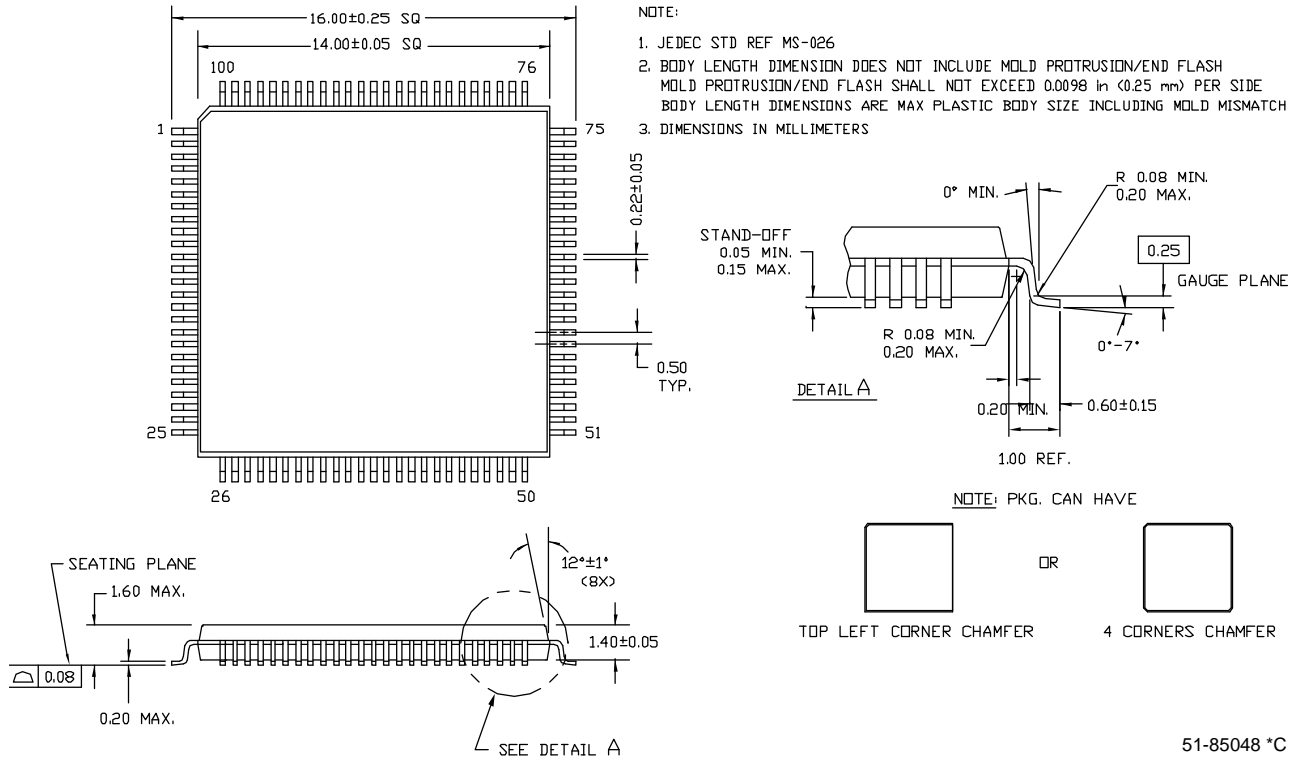

## Document History Page

Document Title: CY7C09269V/79V/89V CY7C09369V/79V/89V 3.3V 16K/32K/64K x 16/18 Synchronous Dual-Port Static RAM				
Document Number: 38-06056				
Revision	ECN	Submission Date	Orig. of Change	Description of Change
**	110215	12/18/01	SZV	Change from Spec number: 38-00668 to 38-06056
*A	122306	12/27/02	RBI	Power up requirements added to Maximum Ratings Information
*B	344354	See ECN	PCX	Added Pb-Free Part Ordering Information
*C	2678221	03/25/2009	VKN/AESA	Added CY7C09379V-12AXCT part. Updated 51-85048 to *C.

## Sales, Solutions, and Legal Information

### Worldwide Sales and Design Support

Cypress maintains a worldwide network of offices, solution centers, manufacturer's representatives, and distributors. To find the office closest to you, visit us at [cypress.com/sales](http://cypress.com/sales).

#### Products

PSoC	<a href="http://psoc.cypress.com">psoc.cypress.com</a>
Clocks & Buffers	<a href="http://clocks.cypress.com">clocks.cypress.com</a>
Wireless	<a href="http://wireless.cypress.com">wireless.cypress.com</a>
Memories	<a href="http://memory.cypress.com">memory.cypress.com</a>
Image Sensors	<a href="http://image.cypress.com">image.cypress.com</a>

#### PSoC Solutions

General	<a href="http://psoc.cypress.com/solutions">psoc.cypress.com/solutions</a>
Low Power/Low Voltage	<a href="http://psoc.cypress.com/low-power">psoc.cypress.com/low-power</a>
Precision Analog	<a href="http://psoc.cypress.com/precision-analog">psoc.cypress.com/precision-analog</a>
LCD Drive	<a href="http://psoc.cypress.com/lcd-drive">psoc.cypress.com/lcd-drive</a>
CAN 2.0b	<a href="http://psoc.cypress.com/can">psoc.cypress.com/can</a>
USB	<a href="http://psoc.cypress.com/usb">psoc.cypress.com/usb</a>

© Cypress Semiconductor Corporation, 2001-2009. The information contained herein is subject to change without notice. Cypress Semiconductor Corporation assumes no responsibility for the use of any circuitry other than circuitry embodied in a Cypress product. Nor does it convey or imply any license under patent or other rights. Cypress products are not warranted nor intended to be used for medical, life support, life saving, critical control or safety applications, unless pursuant to an express written agreement with Cypress. Furthermore, Cypress does not authorize its products for use as critical components in life-support systems where a malfunction or failure may reasonably be expected to result in significant injury to the user. The inclusion of Cypress products in life-support systems application implies that the manufacturer assumes all risk of such use and in doing so indemnifies Cypress against all charges.

Any Source Code (software and/or firmware) is owned by Cypress Semiconductor Corporation (Cypress) and is protected by and subject to worldwide patent protection (United States and foreign), United States copyright laws and international treaty provisions. Cypress hereby grants to licensee a personal, non-exclusive, non-transferable license to copy, use, modify, create derivative works of, and compile the Cypress Source Code and derivative works for the sole purpose of creating custom software and or firmware in support of licensee product to be used only in conjunction with a Cypress integrated circuit as specified in the applicable agreement. Any reproduction, modification, translation, compilation, or representation of this Source Code except as specified above is prohibited without the express written permission of Cypress.

Disclaimer: CYPRESS MAKES NO WARRANTY OF ANY KIND, EXPRESS OR IMPLIED, WITH REGARD TO THIS MATERIAL, INCLUDING, BUT NOT LIMITED TO, THE IMPLIED WARRANTIES OF MERCHANTABILITY AND FITNESS FOR A PARTICULAR PURPOSE. Cypress reserves the right to make changes without further notice to the materials described herein. Cypress does not assume any liability arising out of the application or use of any product or circuit described herein. Cypress does not authorize its products for use as critical components in life-support systems where a malfunction or failure may reasonably be expected to result in significant injury to the user. The inclusion of Cypress' product in a life-support systems application implies that the manufacturer assumes all risk of such use and in doing so indemnifies Cypress against all charges.

Use may be limited by and subject to the applicable Cypress software license agreement.