

REVISIONS			
LTR	DESCRIPTION	DATE (YR-MO-DA)	APPROVED
A	Update drawing to current requirements. Editorial changes throughout. - gap	02-05-22	Raymond Monnin
B	Case outline X descriptive designator changed from CMGA15-P84C to CMGA3-P84C. Boilerplate update, part of 5 year review. ksr	08-01-22	Robert Heber

REV																				
SHEET																				
REV	B	B	B	B	B	B														
SHEET	15	16	17	18	19	20														
REV STATUS OF SHEETS	REV			B	B	B	B	B	B	B	B	B	B	B	B	B	B	B	B	B
	SHEET			1	2	3	4	5	6	7	8	9	10	11	12	13	14			
PMIC N/A	PREPARED BY Kenneth Rice						DEFENSE SUPPLY CENTER COLUMBUS COLUMBUS, OHIO 43218-3990 http://www.dsccl.dla.mil													
STANDARD MICROCIRCUIT DRAWING THIS DRAWING IS AVAILABLE FOR USE BY ALL DEPARTMENTS AND AGENCIES OF THE DEPARTMENT OF DEFENSE AMSC N/A	CHECKED BY Jeff Bowling																			
	APPROVED BY Raymond Monnin						MICROCIRCUIT, MEMORY, DIGITAL, CMOS, ELECTRICALLY ALTERABLE FLASH PROGRAMMABLE LOGIC DEVICE, MONOLITHIC SILICON													
	DRAWING APPROVAL DATE 97-06-27																			
	REVISION LEVEL B						SIZE A	CAGE CODE 67268	5962-97598											
						SHEET 1 OF 20														

1. SCOPE

1.1 Scope. This drawing documents two product assurance class levels consisting of high reliability (device classes Q and M) and space application (device class V). A choice of case outlines and lead finishes are available and are reflected in the Part or Identifying Number (PIN). When available, a choice of Radiation Hardness Assurance (RHA) levels are reflected in the PIN.

1.2 PIN. The PIN is as shown in the following example:

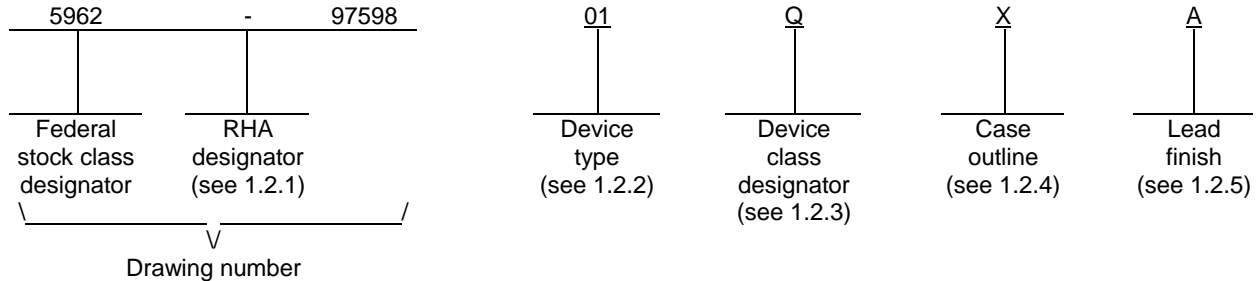

1.2.1 RHA designator. Device classes Q and V RHA marked devices meet the MIL-PRF-38535 specified RHA levels and are marked with the appropriate RHA designator. Device class M RHA marked devices meet the MIL-PRF-38535, appendix A specified RHA levels and are marked with the appropriate RHA designator. A dash (-) indicates a non-RHA device.

1.2.2 Device type(s). The device type(s) identify the circuit function as follows:

<u>Device type</u>	<u>Generic number</u>	<u>Circuit function</u>	<u>Toggle Speed (Mhz)</u>
01	7C374i	128 Macrocell CPLD	66
02	7C374i	128 Macrocell CPLD	83

1.2.3 Device class designator. The device class designator is a single letter identifying the product assurance level as follows:

<u>Device class</u>	<u>Device requirements documentation</u>
M	Vendor self-certification to the requirements for MIL-STD-883 compliant, non-JAN class level B microcircuits in accordance with MIL-PRF-38535, appendix A
Q or V	Certification and qualification to MIL-PRF-38535

1.2.4 Case outline(s). The case outline(s) are as designated in MIL-STD-1835 and as follows:

<u>Outline letter</u>	<u>Descriptive designator</u>	<u>Terminals</u>	<u>Package style</u>
X	CMGA3-P84C	84	Pin grid array
Y	GQCC1-J84	84	J leaded chip carrier

1.2.5 Lead finish. The lead finish is as specified in MIL-PRF-38535 for device classes Q and V or MIL-PRF-38535, appendix A for device class M.

STANDARD MICROCIRCUIT DRAWING DEFENSE SUPPLY CENTER COLUMBUS COLUMBUS, OHIO 43218-3990	SIZE A		5962-97598
		REVISION LEVEL B	SHEET 2

1.3 Absolute maximum ratings. 1/

Supply voltage range (V_{CC})	-2.0 V dc to +7.0 V dc
Programming supply voltage range (V_{PP})	-2.0 V dc to +13.5 V dc 2/
DC input voltage range	-2.0 V dc to +7.0 V dc 2/
Maximum power dissipation	2.5 W 3/
Lead temperature (soldering, 10 seconds)	+260°C
Thermal resistance, junction-to-case (θ_{JC}):	
Case outline X and Y	See MIL-STD-1835
Junction temperature (T_J)	+175°C 4/
Storage temperature range	-65°C to +150°C
Endurance	25 erase/write cycles (minimum)
Data retention	10 years (minimum)

1.4 Recommended operating conditions. 5/

Case operating temperature range (T_C)	-55°C to +125°C
Supply voltage relative to ground (V_{CC})	+4.5 V dc minimum to +5.5 V dc maximum
Ground voltage (GND)	0 V dc
Input high voltage (V_{IH})	2.0 V dc minimum
Input low voltage (V_{IL})	0.8 V dc maximum

2. APPLICABLE DOCUMENTS

2.1 Government specification, standards, and handbooks. The following specification, standards, and handbooks form a part of this drawing to the extent specified herein. Unless otherwise specified, the issues of these documents are those cited in the solicitation or contract.

DEPARTMENT OF DEFENSE SPECIFICATION

MIL-PRF-38535 - Integrated Circuits, Manufacturing, General Specification for.

DEPARTMENT OF DEFENSE STANDARDS

MIL-STD-883 - Test Method Standard Microcircuits.
MIL-STD-1835 - Interface Standard Electronic Component Case Outlines.

DEPARTMENT OF DEFENSE HANDBOOKS

MIL-HDBK-103 - List of Standard Microcircuit Drawings.
MIL-HDBK-780 - Standard Microcircuit Drawings.

(Copies of these documents are available online at <http://assist.daps.dla.mil/quicksearch/> or <http://assist.daps.dla.mil> from the Standardization Document Order Desk, 700 Robins Avenue, Building 4D, Philadelphia, PA 19111-5094.)

2.2 Non-Government publications. The following document(s) form a part of this document to the extent specified herein. Unless otherwise specified, the issues of these documents are those cited in the solicitation.

ELECTRONICS INDUSTRIES ASSOCIATION (EIA)

JEDEC Standard EIA/JESD78 - IC Latch-Up Test.

(Applications for copies should be addressed to the Electronics Industries Association, 2500 Wilson Boulevard, Arlington, VA 22201; <http://www.jedec.org>.)

(Non-Government standards and other publications are normally available from the organizations that prepare or distribute the documents. These documents also may be available in or through libraries or other informational services.)

- 1/ Stresses above the absolute maximum rating may cause permanent damage to the device. Extended operation at the maximum levels may degrade performance and affect reliability.
- 2/ Minimum dc input voltage is -0.5 V, which may overshoot to -2.0 V for periods less than 20 ns. Maximum dc voltage on output pins is $V_{CC} + 0.5$ V, which may overshoot to +7.0 V for periods less than 20 ns under load conditions.
- 3/ Must withstand the added P_D due to short circuit test (e.g., I_{OS}).
- 4/ Maximum junction temperature shall not be exceeded except for allowable short duration burn-in screening conditions in accordance with method 5004 of MIL-STD-883.
- 5/ All voltage values in this drawing are with respect to V_{SS} .

STANDARD MICROCIRCUIT DRAWING DEFENSE SUPPLY CENTER COLUMBUS COLUMBUS, OHIO 43218-3990	SIZE A		5962-97598
		REVISION LEVEL B	SHEET 3

2.3 Order of precedence. In the event of a conflict between the text of this drawing and the references cited herein, the text of this drawing takes precedence. Nothing in this document, however, supersedes applicable laws and regulations unless a specific exemption has been obtained.

3. REQUIREMENTS

3.1 Item requirements. The individual item requirements for device classes Q and V shall be in accordance with MIL-PRF-38535 and as specified herein or as modified in the device manufacturer's Quality Management (QM) plan. The modification in the QM plan shall not affect the form, fit, or function as described herein. The individual item requirements for device class M shall be in accordance with MIL-PRF-38535, appendix A for non-JAN class level B devices and as specified herein.

3.2 Design, construction, and physical dimensions. The design, construction, and physical dimensions shall be as specified in MIL-PRF-38535 and herein for device classes Q and V or MIL-PRF-38535, appendix A and herein for device class M.

3.2.1 Case outlines. The case outlines shall be in accordance with 1.2.4 herein.

3.2.2 Terminal connections. The terminal connections shall be as specified on figure 1.

3.2.3 Truth table. The truth table shall be as specified on figure 2.

3.3 Electrical performance characteristics and postirradiation parameter limits. Unless otherwise specified herein, the electrical performance characteristics and postirradiation parameter limits are as specified in table I and shall apply over the full case operating temperature range.

3.4 Electrical test requirements. The electrical test requirements shall be the subgroups specified in table IIA. The electrical tests for each subgroup are defined in table I.

3.5 Marking. The part shall be marked with the PIN listed in 1.2 herein. In addition, the manufacturer's PIN may also be marked. For packages where marking of the entire SMD PIN number is not feasible due to space limitations, the manufacturer has the option of not marking the "5962-" on the device. For RHA product using this option, the RHA designator shall still be marked. Marking for device classes Q and V shall be in accordance with MIL-PRF-38535. Marking for device class M shall be in accordance with MIL-PRF-38535, appendix A.

3.5.1 Certification/compliance mark. The certification mark for device classes Q and V shall be a "QML" or "Q" as required in MIL-PRF-38535. The compliance mark for device class M shall be a "C" as required in MIL-PRF-38535, appendix A.

3.6 Certificate of compliance. For device classes Q and V, a certificate of compliance shall be required from a QML-38535 listed manufacturer in order to supply to the requirements of this drawing (see 6.6.1 herein). For device class M, a certificate of compliance shall be required from a manufacturer in order to be listed as an approved source of supply in MIL-HDBK-103 (see 6.6.2 herein). The certificate of compliance submitted to DSCC-VA prior to listing as an approved source of supply for this drawing shall affirm that the manufacturer's product meets, for device classes Q and V, the requirements of MIL-PRF-38535 and herein or for device class M, the requirements of MIL-PRF-38535, appendix A and herein.

3.7 Certificate of conformance. A certificate of conformance as required for device classes Q and V in MIL-PRF-38535 or for device class M in MIL-PRF-38535, appendix A shall be provided with each lot of microcircuits delivered to this drawing.

3.8 Notification of change for device class M. For device class M, notification to DSCC-VA of change of product (see 6.2 herein) involving devices acquired to this drawing is required for any change that affects this drawing.

3.9 Verification and review for device class M. For device class M, DSCC, DSCC's agent, and the acquiring activity retain the option to review the manufacturer's facility and applicable required documentation. Offshore documentation shall be made available onshore at the option of the reviewer.

3.10 Microcircuit group assignment for device class M. Device class M devices covered by this drawing shall be in microcircuit group number 42 (see MIL-PRF-38535, appendix A).

3.11 Processing CPLDs. All testing requirements and quality assurance provisions herein shall be satisfied by the manufacturer prior to delivery.

3.11.1 Erasure of CPLDs. When specified, devices shall be erased in accordance with the procedures and characteristics specified in 4.6 herein.

STANDARD MICROCIRCUIT DRAWING DEFENSE SUPPLY CENTER COLUMBUS COLUMBUS, OHIO 43218-3990	SIZE A		5962-97598
		REVISION LEVEL B	SHEET 4

3.11.2 Programmability of CPLDs. When specified, devices shall be programmed to the specified pattern using the procedures and characteristics specified in 4.7 herein.

3.11.3 Verification of erasure or programmed CPLDs. When specified, devices shall be verified as either programmed (see 4.7 herein) to the specified pattern or erased (see 4.6 herein). As a minimum, verification shall consist of performing a functional test (subgroup 7) to verify that all bits are in the proper state. Any bit that does not verify to be in the proper state shall constitute a device failure, and shall be removed from the lot.

3.12 Endurance. A reprogrammability test shall be completed as part of the vendor's reliability monitor. This reprogrammability test shall be done only for initial characterization and after any design or process changes which may affect the reprogrammability of the device. The methods and procedures may be vendor specific, but shall be under document control and shall be made available upon request.

3.13 Data Retention. A data retention stress test shall be completed as part of the vendor's reliability monitors. This test shall be done for initial characterization and after any design or process changes which may affect data retention. The methods and procedures may be vendor specific, but shall guarantee the number of years listed in section 1.3 herein over the full military temperature range. The vendor's procedure shall be kept under document control and shall be made available upon request of the acquiring or preparing activity, along with the test data.

4. VERIFICATION

4.1 Sampling and inspection. For device classes Q and V, sampling and inspection procedures shall be in accordance with MIL-PRF-38535 or as modified in the device manufacturer's Quality Management (QM) plan. The modification in the QM plan shall not affect the form, fit, or function as described herein. For device class M, sampling and inspection procedures shall be in accordance with MIL-PRF-38535, appendix A.

4.2 Screening. For device classes Q and V, screening shall be in accordance with MIL-PRF-38535, and shall be conducted on all devices prior to qualification and technology conformance inspection. For device class M, screening shall be in accordance with method 5004 of MIL-STD-883, and shall be conducted on all devices prior to quality conformance inspection.

4.2.1 Additional criteria for device class M.

- a. Delete the sequence specified as initial (pre-burn-in) electrical parameters through interim (post-burn-in) electrical parameters of method 5004 and substitute lines 1 through 6 of table IIA herein.
- b. Prior to burn-in, the devices shall be programmed (see 4.7 herein) with a checkerboard pattern or equivalent (manufacturers at their option may employ an equivalent pattern provided it is topologically true alternating bit pattern). The pattern shall be read before and after burn-in. Devices having bits not in the proper state after burn-in shall constitute a device failure and shall be removed from the lot. The manufacturer as an option may use built-in test circuitry by testing the entire lot to verify programmability and AC performance without programming the user array.
- c. Burn-in test, method 1015 of MIL-STD-883.
 - (1) Test condition D. The test circuit shall be maintained by the manufacturer under document revision level control and shall be made available to the preparing or acquiring activity upon request. The test circuit shall specify the inputs, outputs, biases, and power dissipation, as applicable, in accordance with the intent specified in method 1015.
 - (2) $T_A = +125^\circ\text{C}$, minimum.
- d. Interim and final electrical test parameters shall be as specified in table IIA herein.

4.2.2 Additional criteria for device classes Q and V.

- a. The burn-in test duration, test condition and test temperature, or approved alternatives shall be as specified in the device manufacturer's QM plan in accordance with MIL-PRF-38535. The burn-in test circuit shall be maintained under document revision level control of the device manufacturer's Technology Review Board (TRB) in accordance with MIL-PRF-38535 and shall be made available to the acquiring or preparing activity upon request. The test circuit shall specify the inputs, outputs, biases, and power dissipation, as applicable, in accordance with the intent specified in method 1015 of MIL-STD-883.

STANDARD MICROCIRCUIT DRAWING DEFENSE SUPPLY CENTER COLUMBUS COLUMBUS, OHIO 43218-3990	SIZE A		5962-97598
		REVISION LEVEL B	SHEET 5

- b. Interim and final electrical test parameters shall be as specified in table IIA herein.
- c. Additional screening for device class V beyond the requirements of device class Q shall be as specified in MIL-PRF-38535, appendix B.

4.3 Qualification inspection for device classes Q and V. Qualification inspection for device classes Q and V shall be in accordance with MIL-PRF-38535. Inspections to be performed shall be those specified in MIL-PRF-38535 and herein for groups A, B, C, D, and E inspections (see 4.4.1 through 4.4.4).

4.4 Conformance inspection. Technology conformance inspection for classes Q and V shall be in accordance with MIL-PRF-38535 including groups A, B, C, D, and E inspections and as specified herein. Quality conformance inspection for device class M shall be in accordance with MIL-PRF-38535, appendix A and as specified herein. Inspections to be performed for device class M shall be those specified in method 5005 of MIL-STD-883 and herein for groups A, B, C, D, and E inspections (see 4.4.1 through 4.4.4).

4.4.1 Group A inspection.

- a. Tests shall be as specified in table IIA herein.
- b. Subgroups 5 and 6 of table I of method 5005 of MIL-STD-883 shall be omitted.
- c. For device class M, subgroups 7, 8A and 8B tests shall be sufficient to verify the truth table. For device classes Q and V, subgroups 7, 8A and 8B shall include verifying the functionality of the device.
- d. O/V (latch-up) tests shall be measured only for initial qualification and after any design or process changes which may affect the performance of the device. For device class M, procedures and circuits shall be maintained under document revision level control by the manufacturer and shall be made available to the preparing activity or acquiring activity upon request. For device classes Q and V, the procedures and circuits shall be under the control of the device manufacturer's TRB in accordance with MIL-PRF-38535 and shall be made available to the preparing activity or acquiring activity upon request. Testing shall be on all pins, on five devices with zero failures. Latch-up test shall be considered destructive. Information contained in EIA/JESD 78 may be used for reference.
- e. Subgroup 4 (C_{IN} and C_{OUT} measurements) shall be measured only for initial qualification and after any process or design changes which may affect input or output capacitance. Capacitance shall be measured between the designated terminal and GND at a frequency of 1 MHz. Sample size is three devices with no failures, and all input and output terminals tested.

4.4.2 Group C inspection. The group C inspection end-point electrical parameters shall be as specified in table IIA herein.

4.4.2.1 Additional criteria for device class M. Steady-state life test conditions, method 1005 of MIL-STD-883:

- a. Test condition D. The test circuit shall be maintained by the manufacturer under document revision level control and shall be made available to the preparing or acquiring activity upon request. The test circuit shall specify the inputs, outputs, biases, and power dissipation, as applicable, in accordance with the intent specified in method 1005 of MIL-STD-883.
- b. $T_A = +125^\circ\text{C}$, minimum.
- c. Test duration: 1,000 hours, except as permitted by method 1005 of MIL-STD-883.

4.4.2.2 Additional criteria for device classes Q and V. The steady-state life test duration, test condition and test temperature, or approved alternatives shall be as specified in the device manufacturer's QM plan in accordance with MIL-PRF-38535. The test circuit shall be maintained under document revision level control by the device manufacturer's TRB in accordance with MIL-PRF-38535 and shall be made available to the acquiring or preparing activity upon request. The test circuit shall specify the inputs, outputs, biases, and power dissipation, as applicable, in accordance with the intent specified in method 1005 of MIL-STD-883.

4.4.3 Group D inspection. The group D inspection end-point electrical parameters shall be as specified in table IIA herein.

STANDARD MICROCIRCUIT DRAWING DEFENSE SUPPLY CENTER COLUMBUS COLUMBUS, OHIO 43218-3990	SIZE A		5962-97598
		REVISION LEVEL B	SHEET 6

TABLE I. Electrical performance characteristics.

Test	Symbol	Conditions 4.5 V ≤ V _{CC} ≤ 5.5 V -55°C ≤ T _C ≤ +125°C unless otherwise specified	Group A Subgroups	Device types	Limits		Unit
					Min	Max	
High Level output voltage	V _{OH}	V _{CC} = 4.5 V, V _{IL} = 0.8V I _{OH} = -2.0 mA, V _{IH} = 2.0 V	1, 2, 3	All	2.4		V
Low level output voltage	V _{OL}	V _{CC} = 4.5 V, I _{OL} = 12.0 mA V _{IL} = 0.8 V, V _{IH} = 2.0 V		All		0.5	V
High level input voltage <u>1/</u>	V _{IH}			All	2.0	7.0	V
Low level input voltage <u>1/</u>	V _{IL}			All	-0.5	0.8	V
Input leakage current	I _{IX}	V _{CC} = 5.5 V, V _{IN} = 0 V and 5.5 V		All	-10	+10	μA
Output leakage current	I _{OZ}	V _{CC} = 5.5 V, V _{IN} = output disabled and 5.5 V		All	-50	+50	μA
Output short circuit current <u>2/ 3/</u>	I _{OS}	V _{CC} = 5.5 V, V _{OUT} = 0.5 V		All	-30	-160	mA
Power supply current <u>4/</u>	I _{CC}	V _{CC} = 5.5 V, I _{OUT} = 0 mA, V _{IN} = 0 V and 5.5 V f = 1.0 MHz		All		250	mA
Input bus hold low sustained current	I _{BHL}	V _{CC} = 4.5 V, V _{IL} = 0.8 V		All	+75		μA
Input bus hold high sustained current	I _{BHH}	V _{CC} = 4.5 V, V _{IH} = 2.0 V		All	-75		μA
Input bus hold low sustained overdrive current	I _{BHLO}	V _{CC} = 5.5 V		All		+500	μA
Input bus hold high sustained overdrive current	I _{BHHO}	V _{CC} = 5.5 V		All		-500	μA
Input capacitance <u>2/</u>	C _{IN}	V _{IN} = 5.0 V, f = 1MHz See 4.4.1e	4	All		8	pF
Output capacitance <u>2/</u>	C _{OUT}		4	All	5	15	pF
Functional test		See 4.4.1c	7, 8A, 8B	All			
Input to combinatorial output <u>5/</u>	t _{PD}	See figures 3 and 4 (circuit A)	9, 10, 11	01		20	ns
				02		15	
Input to output through transparent input or output latch <u>5/ 6/</u>	t _{PDL}			01		22	ns
					02		

See footnotes at end of table.

STANDARD MICROCIRCUIT DRAWING DEFENSE SUPPLY CENTER COLUMBUS COLUMBUS, OHIO 43218-3990	SIZE A		5962-97598
		REVISION LEVEL B	SHEET 7

TABLE I. Electrical performance characteristics - Continued.

Test	Symbol	Conditions 4.5 V ≤ V _{CC} ≤ 5.5 V -55°C ≤ T _C ≤ +125°C unless otherwise specified	Group A Subgroups	Device types	Limits		Unit
					Min	Max	
Input to output through transparent input or output latches <u>5/ 6/</u>	t _{PDLL}	See figures 3 and 4 (circuit A)	9, 10, 11	01		24	ns
				02		19	
Input to output enable <u>5/ 6/</u>	t _{EA}	See figures 3 and 4 (circuit B)		01		24	ns
				02		19	
Input to output disable <u>5/ 6/</u>	t _{ER}			01		24	ns
				02		19	
Clock or latch enable input high time <u>2/ 5/</u>	t _{WH}	See figures 3 and 4 (circuit A)		01	5		ns
				02	4		
Clock or latch enable input low time <u>2/ 5/</u>	t _{WL}			01	5		ns
				02	4		
Input register or latch set-up time <u>5/</u>	t _{IS}			01	4		ns
				02	3		
Input register or latch hold time <u>5/</u>	t _{IH}			01	4		ns
				02	3		
Input register clock or latch enable to combinatorial output <u>5/</u>	t _{ICO}			01		24	ns
				02		19	
Input register clock or latch enable to output through transparent output latch <u>5/ 6/</u>	t _{ICOL}			01		26	ns
				02		21	
Clock or latch enable to output <u>5/</u>	t _{CO}			01		10	ns
				02		8	
Register or latch data hold time <u>5/</u>	t _H			All	0		ns
Set-up time from input to clock or latch enable <u>5/</u>	t _S			01	10		ns
				02	8		

See footnotes at end of table.

STANDARD MICROCIRCUIT DRAWING DEFENSE SUPPLY CENTER COLUMBUS COLUMBUS, OHIO 43218-3990	SIZE A		5962-97598
		REVISION LEVEL B	SHEET 8

TABLE I. Electrical performance characteristics - Continued.

Test	Symbol	Conditions 4.5 V ≤ V _{CC} ≤ 5.5 V -55°C ≤ T _C ≤ +125°C unless otherwise specified	Group A Subgroups	Device types	Limits		Unit
					Min	Max	
Set-up time from input through transparent latch to output register clock or latch enable <u>5/ 6/</u>	t _{SL}	See figures 3 and 4 (circuit A)	9, 10, 11	01	20		ns
				02	15		
Output clock or latch enable to output delay (through memory array) <u>5/ 6/</u>	t _{CO2}			01		24	ns
				02		19	
Output clock or latch enable to output clock or latch enable (through memory array) <u>5/ 6/</u>	t _{SCS}			01	15		ns
				02	12		
Hold time for input through transparent latch from output register clock or latch enable <u>5/ 6/</u>	t _{HL}			All	0		ns
Maximum frequency with internal feedback in output register mode (least of 1/t _{SCS} , 1/(t _S + 1/t _H), or 1/t _{CO}) <u>2/ 5/</u>	f _{MAX1}			01	66		MHz
				02	83		
Maximum frequency data path in output register/latched mode (lesser of 1/(t _{WL} + t _{WH}), 1/(t _S + t _H), or 1/t _{CO}) <u>2/ 5/</u>	f _{MAX2}			01	100		
				02	125		
Maximum frequency with external feedback (lesser of 1/(t _{CO} + t _S), or 1/(t _{WL} + t _{WH}) <u>2/ 5/</u>	f _{MAX3}			01	50		
				02	67.5		
Maximum frequency in pipelined mode (least of 1/(t _{CO} + t _{IS}), 1/t _{ICS} , 1/(t _{WL} + t _{WH}), 1/(t _{IS} + t _{IH}), or 1/t _{SCS}) <u>2/ 5/</u>	f _{MAX4}			01	66.6		
				02	83.3		
Output data stable from output clock minus input register hold time for device <u>2/ 5/ 7/</u>	t _{OH} -t _{IH}			All	0		ns
Input register clock to output register clock <u>6/</u>	t _{ICS}			01	15		ns
				02	12		
Asynchronous preset width <u>2/ 5/ 6/</u>	t _{PW}			01	20		ns
				02	15		
Asynchronous preset recovery time <u>2/ 5/ 6/</u>	t _{PR}			01	22		ns
				02	17		

See footnotes at end of table.

STANDARD MICROCIRCUIT DRAWING DEFENSE SUPPLY CENTER COLUMBUS COLUMBUS, OHIO 43218-3990	SIZE A		5962-97598
		REVISION LEVEL B	SHEET 9

TABLE I. Electrical performance characteristics - Continued.

Test	Symbol	Conditions 4.5 V ≤ V _{CC} ≤ 5.5 V -55°C ≤ T _C ≤ +125°C unless otherwise specified	Group A Subgroups	Device types	Limits		Unit
					Min	Max	
Asynchronous preset to output <u>5/ 6/</u>	t _{PO}	See figures 3 and 4 (circuit A)	9, 10, 11	01		26	ns
				02		21	
Asynchronous reset width <u>5/ 6/</u>	t _{RW}			01	20		ns
				02	15		
Asynchronous reset recovery time <u>5/ 6/</u>	t _{RR}			01	22		ns
				02	17		
Asynchronous reset to output <u>5/ 6/</u>	t _{RO}			01		26	ns
				02		21	
Top controller frequency	f _{TAP}		All	500		KHz	

1/ These are absolute values with respect to device ground, and all overshoots due to system or tester noise are included.

2/ Tested initially and after any design or process changes that affect this parameter.

3/ Not more than one output should be tested at a time. Duration of the short circuit should not exceed 1 second. V_{OUT} = 0.5 V has been chosen to avoid test problems caused by tester ground degradation.

4/ Measured with 16-bit counter programmed into each logic block.

5/ All AC parameters are measured with 16 outputs switching.

6/ May not be tested but shall be guaranteed to the limits specified in table I.

7/ This specification is intended to guarantee interface compatibility with the other members of the device family, contact manufacturer for additional information.

STANDARD MICROCIRCUIT DRAWING DEFENSE SUPPLY CENTER COLUMBUS COLUMBUS, OHIO 43218-3990	SIZE A		5962-97598
		REVISION LEVEL B	SHEET 10

Case outline X

Device type	All		Device type	All
Terminal number	Terminal symbol		Terminal number	Terminal symbol
A1	I/O		G1	CLK/I
A2	I/O		G2	I/O
A3	I/O		G3	GND
A4	I/O		G9	CLK/I
A5	V _{CC}		G10	I/O
A6	GND		G11	I/O
A7	I/O		H1	I/O
A8	I/O		H2	I/O
A9	I/O		H10	I/O
A10	I/O		H11	I/O
A11	I/O		J1	I/O
B1	I/O		J2	I/O
B2	GND		J5	I/O
B3	I/O		J6	V _{CC}
B4	I/O		J7	GND
B5	I/O		J10	I/O
B6	I/O		J11	I/O
B7	I/O		K1	I/O
B8	I/O		K2	GND
B9	I/O		K3	I/O
B10	GND		K4	I/O
B11	I/O		K5	I/O
C1	I/O		K6	I
C2	I/O		K7	I/O
C5	I/O		K8	I/O
C6	V _{CC}		K9	I/O
C7	ISREN		K10	GND
C10	I/O		K11	I/O
C11	I/O		L1	I/O
D1	I/O		L2	I/O
D2	I/O		L3	I/O
D10	I/O		L4	I/O
D11	I/O		L5	I/O
E1	I/O		L6	I/O
E2	I/O		L7	V _{CC}
E3	I/O		L8	I/O
E9	I/O		L9	I/O
E10	I/O		L10	I/O
E11	CLK/I		L11	I/O
F1	I/O			
F2	CLK/I			
F3	V _{CC}			
F9	V _{CC}			
F10	I/O			
F11	GND			

FIGURE 1. Terminal connections.

STANDARD MICROCIRCUIT DRAWING DEFENSE SUPPLY CENTER COLUMBUS COLUMBUS, OHIO 43218-3990	SIZE A		5962-97598
		REVISION LEVEL B	SHEET 11

Case outline Y

Device type	All	Device type	All	Device type	All
Terminal number	Terminal symbol	Terminal number	Terminal symbol	Terminal number	Terminal symbol
1	GND	29	I/O	57	I/O
2	V _{CC}	30	I/O	58	I/O
3	I/O	31	I/O	59	I/O
4	I/O	32	GND	60	I/O
5	I/O	33	I/O	61	I/O
6	I/O	34	I/O	62	CLK/I
7	I/O	35	I/O/SMODE	63	V _{CC}
8	I/O	36	I/O	64	GND
9	I/O	37	I/O	65	CLK/I
10	I/O	38	I/O	66	I/O
11	GND	39	I/O	67	I/O
12	I/O	40	I/O	68	I/O
13	I/O	41	I	69	I/O
14	I/O/SCLK	42	V _{CC}	70	I/O
15	I/O	43	GND	71	I/O
16	I/O	44	V _{CC}	72	I/O/SDI
17	I/O	45	I/O	73	I/O
18	I/O	46	I/O	74	GND
19	I/O	47	I/O	75	I/O
20	CLK/I	48	I/O	76	I/O
21	V _{CC}	49	I/O	77	I/O
22	GND	50	I/O	78	I/O
23	CLK/I	51	I/O/SDO	79	I/O
24	I/O	52	I/O	80	I/O
25	I/O	53	GND	81	I/O
26	I/O	54	I/O	82	I/O
27	I/O	55	I/O	83	ISREN
28	I/O	56	I/O	84	V _{CC}

FIGURE 1. Terminal connections - Continued.

STANDARD MICROCIRCUIT DRAWING DEFENSE SUPPLY CENTER COLUMBUS COLUMBUS, OHIO 43218-3990	SIZE A		5962-97598
		REVISION LEVEL B	SHEET 12

Truth table		
Input pins		Output pins
I/CLK	I	I/O
X	X	Z

- NOTES:
1. X = Don't care
 2. Z = High impedance

FIGURE 2. Truth table (unprogrammed).

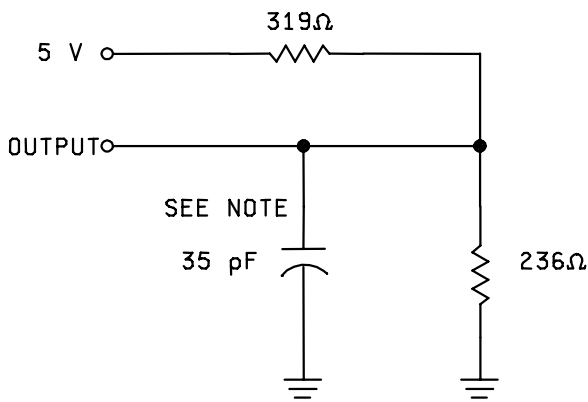

CIRCUIT A
OUTPUT LOAD

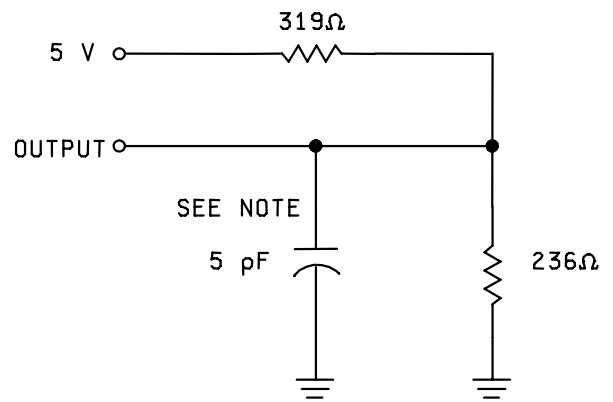

CIRCUIT B
OUTPUT LOAD (tEA and tER)

THEVENIN EQUIVALENT

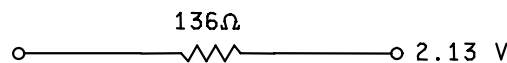

NOTE: INCLUDING SCOPE AND JIG (MINIMUM VALUES).

FIGURE 3. Output load circuits and test conditions.

STANDARD MICROCIRCUIT DRAWING DEFENSE SUPPLY CENTER COLUMBUS COLUMBUS, OHIO 43218-3990	SIZE A		5962-97598
		REVISION LEVEL B	SHEET 13

Test Waveforms

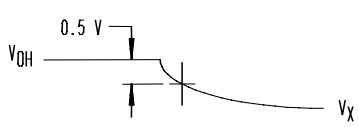
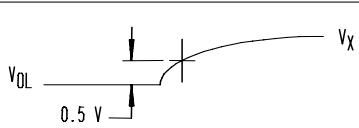
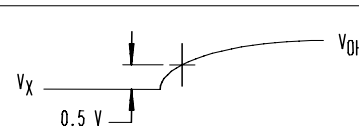
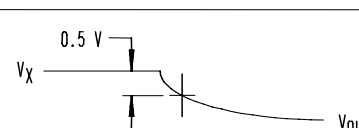
PARAMETER	V_X	OUTPUT WAVEFORM - MEASUREMENT LEVEL
$t_{ER(-)}$	1.5 V	
$t_{ER(+)}$	2.6 V	
$t_{EA(+)}$	1.5 V	
$t_{EA(-)}$	V_{thc}	

Input pulses

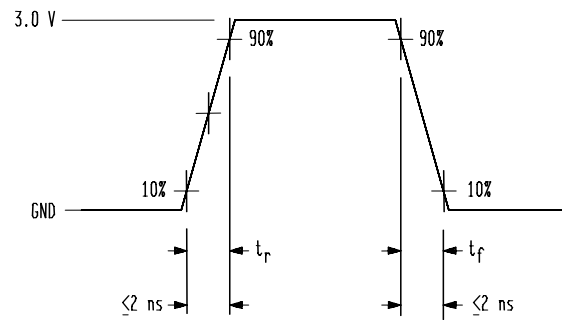

FIGURE 3. Output load circuits and test conditions - Continued.

**STANDARD
MICROCIRCUIT DRAWING**
DEFENSE SUPPLY CENTER COLUMBUS
COLUMBUS, OHIO 43218-3990

SIZE
A

5962-97598

REVISION LEVEL
B

SHEET
14

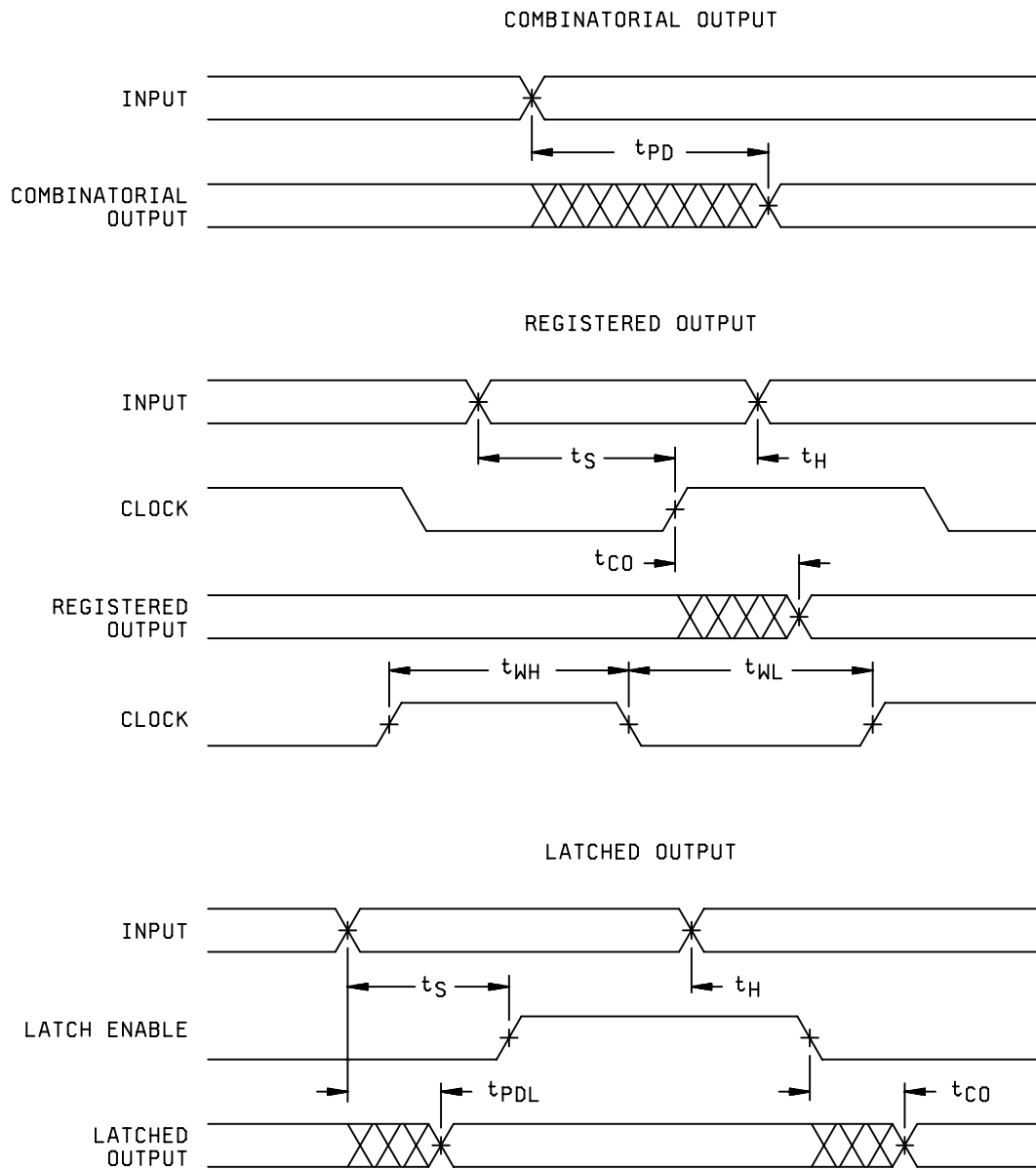

FIGURE 4. Switching waveforms.

**STANDARD
MICROCIRCUIT DRAWING**
DEFENSE SUPPLY CENTER COLUMBUS
COLUMBUS, OHIO 43218-3990

SIZE
A

5962-97598

REVISION LEVEL
B

SHEET
15

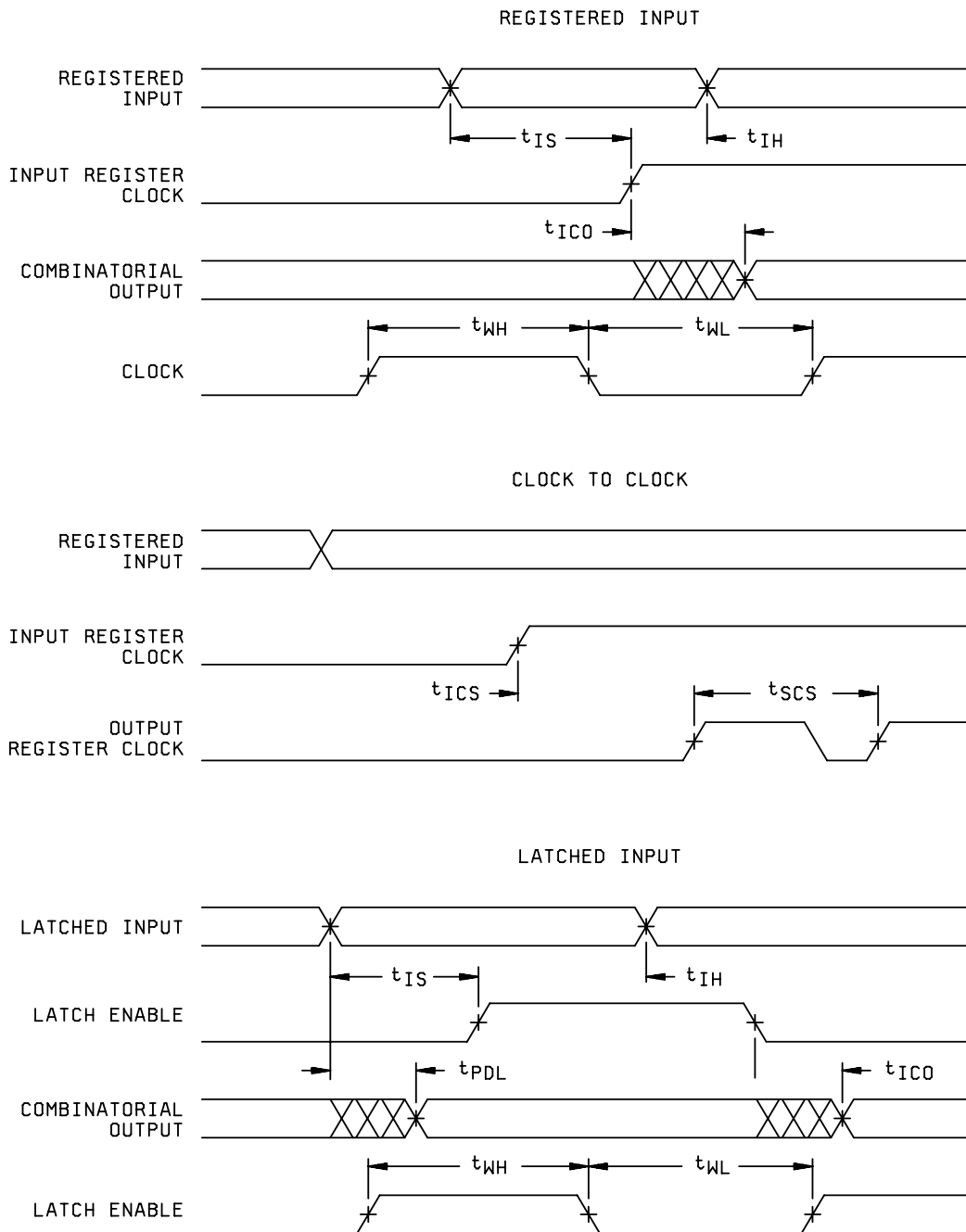

FIGURE 4. Switching waveforms - Continued.

STANDARD MICROCIRCUIT DRAWING DEFENSE SUPPLY CENTER COLUMBUS COLUMBUS, OHIO 43218-3990	SIZE A		5962-97598
		REVISION LEVEL B	SHEET 16

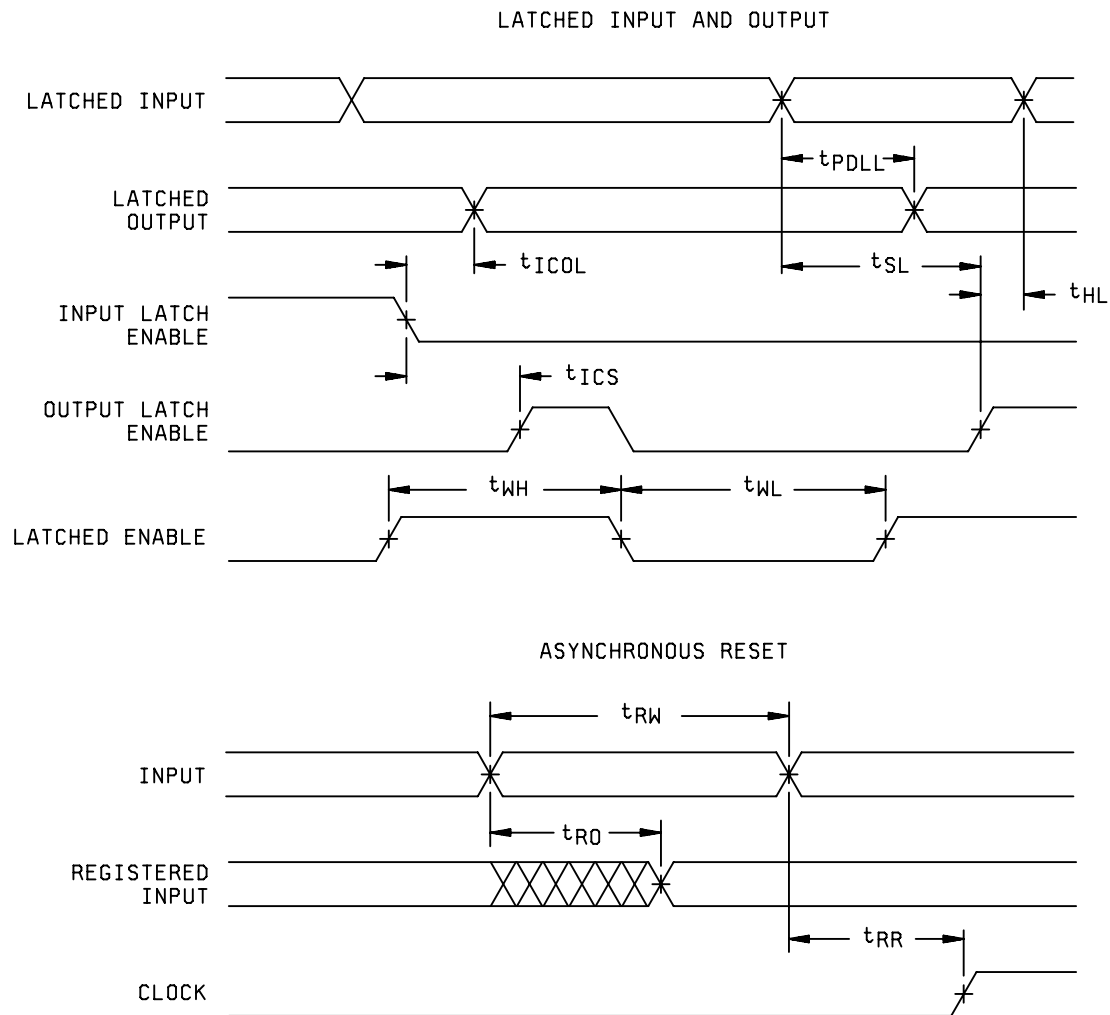

FIGURE 4. Switching waveforms - Continued.

STANDARD MICROCIRCUIT DRAWING DEFENSE SUPPLY CENTER COLUMBUS COLUMBUS, OHIO 43218-3990	SIZE A		5962-97598
		REVISION LEVEL B	SHEET 17

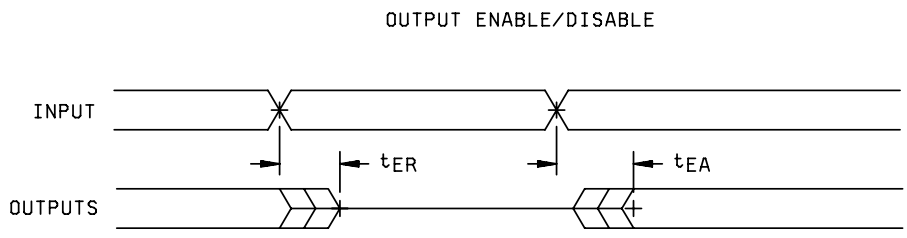
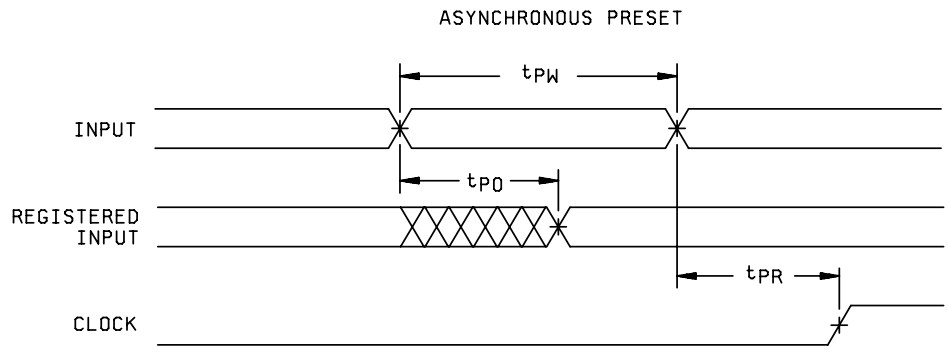

FIGURE 4. Switching waveforms - Continued.

STANDARD MICROCIRCUIT DRAWING DEFENSE SUPPLY CENTER COLUMBUS COLUMBUS, OHIO 43218-3990	SIZE A		5962-97598
		REVISION LEVEL B	SHEET 18

TABLE IIA. Electrical test requirements. 1/ 2/ 3/ 4/ 5/ 6/ 7/

Line no.	Test requirements	Subgroups (in accordance with MIL-STD-883, TM 5005, table I)	Subgroups (in accordance with MIL-PRF-38535, table III)	
		Device class M	Device class Q	Device class V
1	Interim electrical parameters (see 4.2)			1, 7, 9 or 2, 8A, 10
2	Static burn-in (method 1015)	Not required	Not required	Required
3	Same as line 1			1*, 7* Δ
4	Dynamic burn-in (method 1015)	Required	Required	Required
5	Final electrical parameters (see 4.2)	1*, 2, 3, 7*, 8A, 8B, 9, 10, 11	1*, 2, 3, 7*, 8A, 8B, 9, 10, 11	1*, 2, 3, 7*, 8A, 8B, 9, 10, 11
6	Group A test requirements (see 4.4)	1, 2, 3, 4**, 7, 8A, 8B, 9, 10, 11	1, 2, 3, 4**, 7, 8A, 8B, 9, 10, 11	1, 2, 3, 4**, 7, 8A, 8B, 9, 10, 11
7	Group C end-point electrical parameters (see 4.4)	2, 3, 7, 8A, 8B	2, 3, 7, 8A, 8B	1, 2, 3, 7, 8A, 8B, 9, 10, 11 Δ
8	Group D end-point electrical parameters (see 4.4)	2, 3, 8A, 8B	2, 3, 8A, 8B	2, 3, 8A, 8B
9	Group E end-point electrical parameters (see 4.4)	1, 7, 9	1, 7, 9	1, 7, 9

1/ Blank spaces indicate tests are not applicable.

2/ Any or all subgroups may be combined when using high-speed testers.

3/ Subgroups 7, 8A, and 8B functional tests shall verify the truth table.

4/ * indicates PDA applies to subgroup 1 and 7.

5/ ** see 4.4.1e.

6/ Δ indicates delta limit (see table IIB) shall be required where specified, and the delta values shall be computed with reference to the previous interim electrical parameters (see line 1).

7/ See 4.4.1d.

TABLE IIB. Delta limits at +25°C.

Parameter 1/	Device types
	All
I_{OZ}	± 10% of the specified value in table I
I_{IX}	± 10% of the specified value in table I

1/ The above parameter shall be recorded before and after the required burn-in and life tests to determine the delta Δ.

STANDARD MICROCIRCUIT DRAWING DEFENSE SUPPLY CENTER COLUMBUS COLUMBUS, OHIO 43218-3990	SIZE A		5962-97598
		REVISION LEVEL B	SHEET 19

4.4.4 Group E inspection. Group E inspection is required only for parts intended to be marked as radiation hardness assured (see 3.5 herein).

- a. End-point electrical parameters shall be as specified in table IIA herein.
- b. For device classes Q and V, the devices or test vehicle shall be subjected to radiation hardness assured tests as specified in MIL-PRF-38535 for the RHA level being tested. For device class M, the devices shall be subjected to radiation hardness assured tests as specified in MIL-PRF-38535, appendix A for the RHA level being tested. All device classes must meet the postirradiation end-point electrical parameter limits as defined in table I at $T_A = +25^{\circ}\text{C} \pm 5^{\circ}\text{C}$, after exposure, to the subgroups specified in table IIA herein.
- c. When specified in the purchase order or contract, a copy of the RHA delta limits shall be supplied.

4.5 Delta measurements for device class V. Delta measurements, as specified in table IIA, shall be made and recorded before and after the required burn-in screens and steady-state life tests to determine delta compliance. The electrical parameters to be measured, with associated delta limits are listed in table IIB. The device manufacturer may, at his option, either perform delta measurements or within 24 hours after life test perform final electrical parameter tests, subgroups 1, 7, and 9.

4.6 Erasure procedures. Erasure procedures shall be as specified by the device manufacturer and shall be made available upon request.

4.7 Programming procedures. The programming procedures shall be as specified by the device manufacturer and shall be made available upon request.

5. PACKAGING

5.1 Packaging requirements. The requirements for packaging shall be in accordance with MIL-PRF-38535 for device classes Q and V or MIL-PRF-38535, appendix A for device class M.

6. NOTES

6.1 Intended use. Microcircuits conforming to this drawing are intended for use for Government microcircuit applications (original equipment), design applications, and logistics purposes.

6.1.1 Replaceability. Microcircuits covered by this drawing will replace the same generic device covered by a contractor prepared specification or drawing.

6.1.2 Substitutability. Device class Q devices will replace device class M devices.

6.2 Configuration control of SMD's. All proposed changes to existing SMD's will be coordinated with the users of record for the individual documents. This coordination will be accomplished using DD Form 1692, Engineering Change Proposal.

6.3 Record of users. Military and industrial users should inform Defense Supply Center Columbus (DSCC) when a system application requires configuration control and which SMD's are applicable to that system. DSCC will maintain a record of users and this list will be used for coordination and distribution of changes to the drawings. Users of drawings covering microelectronic devices (FSC 5962) should contact DSCC-VA, telephone (614) 692-0544.

6.4 Comments. Comments on this drawing should be directed to DSCC-VA, Columbus, Ohio 43218-3990, or telephone (614) 692-0547.

6.5 Abbreviations, symbols, and definitions. The abbreviations, symbols, and definitions used herein are defined in MIL-PRF-38535 and MIL-HDBK-1331.

6.6 Sources of supply.

6.6.1 Sources of supply for device classes Q and V. Sources of supply for device classes Q and V are listed in QML-38535. The vendors listed in QML-38535 have submitted a certificate of compliance (see 3.6 herein) to DSCC-VA and have agreed to this drawing.

6.6.2 Approved sources of supply for device class M. Approved sources of supply for class M are listed in MIL-HDBK-103. The vendors listed in MIL-HDBK-103 have agreed to this drawing and a certificate of compliance (see 3.6 herein) has been submitted to and accepted by DSCC-VA.

STANDARD MICROCIRCUIT DRAWING DEFENSE SUPPLY CENTER COLUMBUS COLUMBUS, OHIO 43218-3990	SIZE A		5962-97598
		REVISION LEVEL B	SHEET 20

STANDARD MICROCIRCUIT DRAWING BULLETIN

DATE: 08-01-22

Approved sources of supply for SMD 5962-97598 are listed below for immediate acquisition information only and shall be added to MIL-HDBK-103 and QML-38535 during the next revision. MIL-HDBK-103 and QML-38535 will be revised to include the addition or deletion of sources. The vendors listed below have agreed to this drawing and a certificate of compliance has been submitted to and accepted by DSCC-VA. This information bulletin is superseded by the next dated revision of MIL-HDBK-103 and QML-38535. DSCC maintains an online database of all current sources of supply at <http://www.dscclia.mil/Programs/Smcr/>.

Standard microcircuit drawing PIN <u>1/</u>	Vendor CAGE number	Vendor similar PIN <u>2/</u>
5962-9759801QXC <u>3/</u>	0C7V7	CY7C374i-66GMB
5962-9759801QYA	0C7V7	CY7C374i-66YMB
5962-9759802QXC	0C7V7	CY7C374i-83GMB
5962-9759802QYA	0C7V7	CY7C374i-83YMB

- 1/ The lead finish shown for each PIN representing a hermetic package is the most readily available from the manufacturer listed for that part. If the desired lead finish is not listed contact the vendor to determine its availability.
- 2/ Caution. Do not use this number for item acquisition. Items acquired to this number may not satisfy the performance requirements of this drawing.
- 3/ The approved source has indicated an end of life of 08-05-2003

Vendor CAGE
number

0C7V7

Vendor name
and address

QP Semiconductor
2945 Oakmead Village Court
Santa Clara, CA 95051

The information contained herein is disseminated for convenience only and the Government assumes no liability whatsoever for any inaccuracies in the information bulletin.