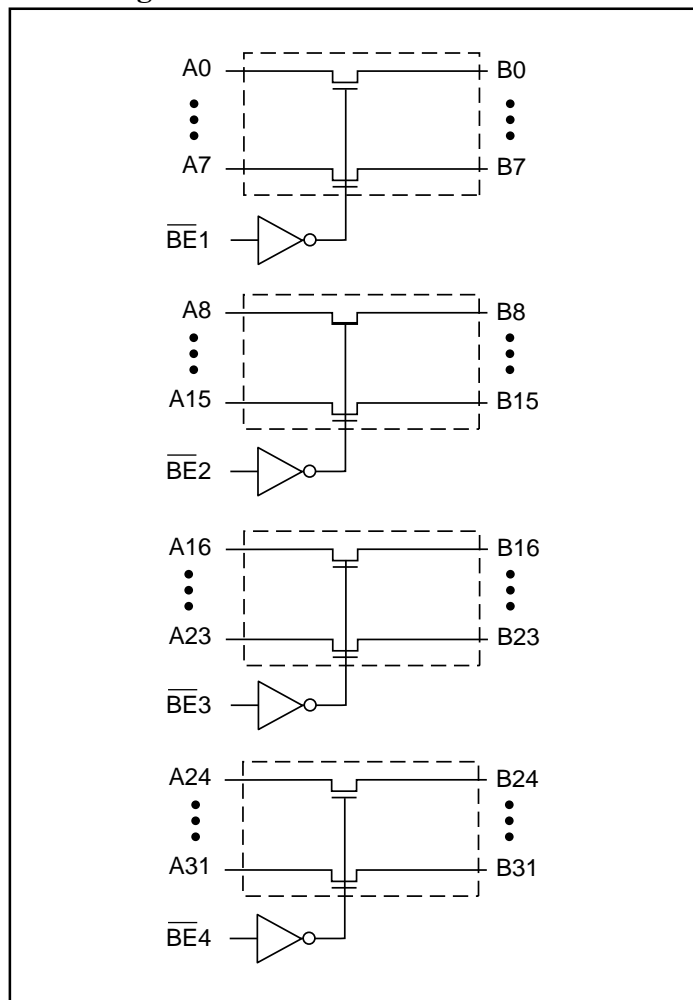

**2.5V/3.3V, High Bandwidth, Hot Insertion
32-Bit, 2-Port, Bus Switch**
Features

- Near-Zero propagation delay
- 5-ohm switches connect inputs to outputs
- 2.5V Supply Voltage Operation
- Permits Hot Insertion
- 5V I/O Tolerant
- High Bandwidth Operation (>400 MHz)
- Packaging (Pb-free & Green available):
 - 80-pin 150-mil wide plastic BQSOP (B)

Description

Pericom Semiconductor's PI3C34X245 is a 2.5V or 3.3V, 32-bit, 2-port bus switch designed with a low On-Resistance (5-ohms) allowing inputs to be connected directly to outputs. The bus switch creates no additional propagational delay or additional ground bounce noise. The switches are turned ON by the Bus Enable (\overline{BE}) input signal. It is very useful in switching signals that have high bandwidth (>400MHz).

Block Diagram

Pin Description

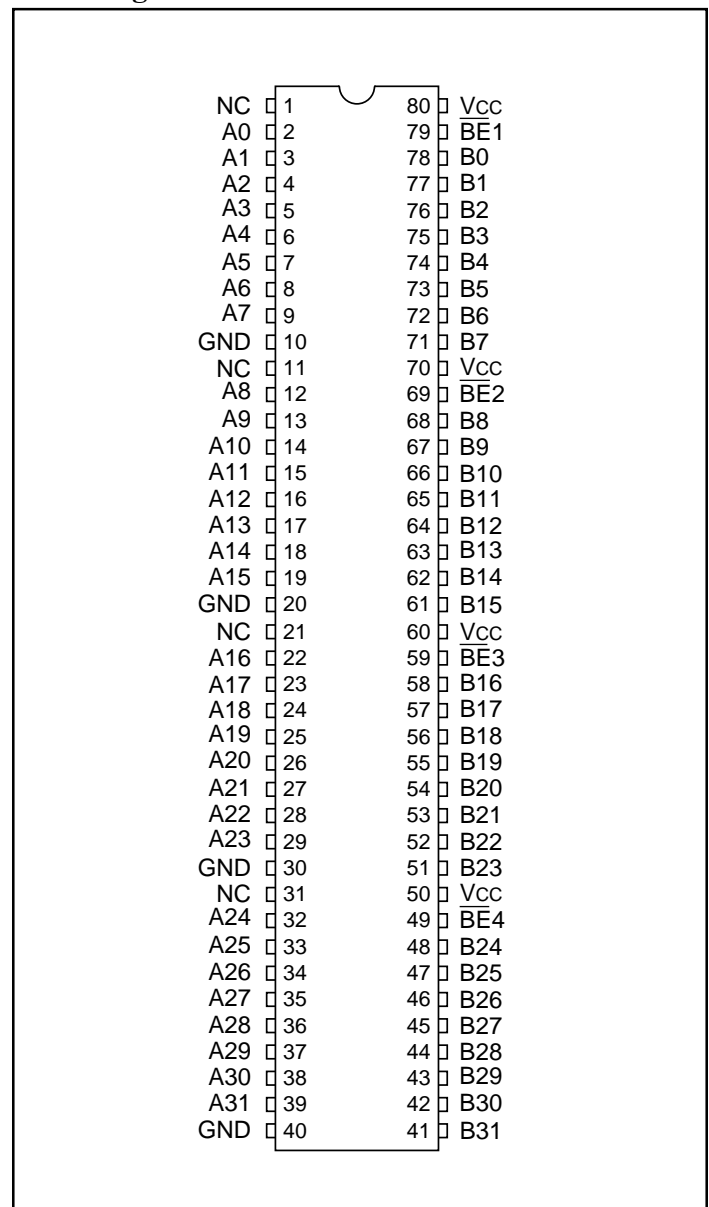
Pin Name	Description
\overline{BE}_n	Bus Enable Input (Active LOW)
A0 – A31	Bus A
B0 – B31	Bus B

Pin Configuration

Maximum Ratings

(Above which the useful life may be impaired. For user guidelines, not tested.)

Storage Temperature	-65°C to +150°C
Ambient Temperature with Power Applied	-40°C to +85°C
Supply Voltage to Ground Potential	-0.5V to +4.6V
DC Input Voltage	-0.5V to +5.5V
DC Output Current	120mA
Power Dissipation	0.5W

Note:

Stresses greater than those listed under MAXIMUM RATINGS may cause permanent damage to the device. This is a stress rating only and functional operation of the device at these or any other conditions above those indicated in the operational sections of this specification is not implied. Exposure to absolute maximum rating conditions for extended periods may affect reliability.

DC Electrical Characteristics (Over Operating Range, $T_A = -40^\circ\text{C}$ to $+85^\circ\text{C}$, $V_{CC} = 3.3\text{V} \pm 10\%$)

Parameters	Description	Test Conditions ⁽¹⁾	Min.	Typ ⁽²⁾	Max.	Units
V_{IH}	Input HIGH Voltage	Guaranteed Logic HIGH Level	2.0			V
V_{IL}	Input LOW Voltage	Guaranteed Logic LOW Level	-0.5		0.8	
I_{IH}	Input HIGH Current	$V_{CC} = \text{Max.}, V_{IN} = V_{CC}$			± 1	μA
I_{IL}	Input LOW Current	$V_{CC} = \text{Max.}, V_{IN} = \text{GND}$			± 1	
I_{OZH}	High Impedance Output Current	$0 \leq A, B \leq V_{CC}$			± 1	
V_{IK}	Clamp Diode Voltage	$V_{CC} = \text{Min.}, I_{IN} = -18\text{mA}$		-0.73	-1.2	V
R_{ON}	Switch On Resistance ⁽³⁾	$V_{CC} = \text{Min.}, V_{IN} = 0.0\text{V}, I_{ON} = 48\text{mA}$ $V_{CC} = \text{Min.}, V_{IN} = 2.4\text{V}, I_{ON} = 15\text{mA}$		5 8	7 15	Ω

Capacitance ($T_A = 25^\circ\text{C}$, $f = 1\text{MHz}$)

Parameters ⁽⁴⁾	Description	Test Conditions	Typ.	Units
C_{IN}	Input Capacitance	$V_{IN} = 0\text{V}$	3.5	pF
C_{OFF}	A/B Capacitance, Switch Off		5.0	
C_{ON}	A/B Capacitance, Switch On		10.0	

Notes:

1. For Max. or Min. conditions, use appropriate value specified under Electrical Characteristics for the applicable device type.
2. Typical values are at $V_{CC} = 3.3\text{V}$, $T_A = 25^\circ\text{C}$ ambient and maximum loading.
3. Measured by the voltage drop between A and B pin at indicated current through the switch. On-Resistance is determined by the lower of the voltages on the two (A,B) pins.
4. This parameter is determined by device characterization but is not production tested.

Power Supply Characteristics

Parameters	Description	Test Conditions ⁽¹⁾		Min.	Typ ⁽²⁾	Max.	Units
I_{CC}	Quiescent Power Supply Current	$V_{CC} = \text{Max.}$	$V_{IN} = \text{GND or } V_{CC}$	—	1.0	2.0	mA
ΔI_{CC}	Supply Current per Input @ TTL HIGH		$V_{IN} = 3.0\text{V}^{(3)}$	—	—	2.5	

Notes:

1. For Max. or Min. conditions, use appropriate value specified under Electrical Characteristics for the applicable device.
2. Typical values are at $V_{CC} = 3.3\text{V}$, +25°C ambient.
3. Per driven input (control input only); A and B pins do not contribute to ΔI_{CC} .

Switching Characteristics over 3.3V Operating Range

Parameters	Description	Conditions	PI3C34X245		Units
			Com.		
			Min.	Max.	
t_{PLH} t_{PHL}	Propagation Delay ^(2,3) Ax to Bx	$C_L = 50\text{pF}$ $R_L = 500 \text{ ohms}$		0.25	ns
t_{PZH} t_{PZL}	Bus Enable Time $\overline{\text{BE}}$ to Ax or Bx	$C_L = 50\text{pF}$ $R_L = 500 \text{ ohms}$ $R = 500 \text{ ohms}$	1.5	6.5	
t_{PHZ} t_{PLZ}	Bus Disable Time $\overline{\text{BE}}$ to Ax or Bx		1.5	5.5	

Switching Characteristics over 2.5V Operating Range

Parameters	Description	Conditions	PI3C34X245		Units
			Com.		
			Min.	Max.	
t_{PLH} t_{PHL}	Propagation Delay ^(2,3) Ax to Bx	$C_L = 50\text{pF}$ $R_L = 500 \text{ ohms}$		0.25	ns
t_{PZH} t_{PZL}	Bus Enable Time $\overline{\text{BE}}$ to Ax or Bx	$C_L = 50\text{pF}$ $R_L = 500 \text{ ohms}$ $R = 500 \text{ ohms}$	1.5	9.8	
t_{PHZ} t_{PLZ}	Bus Disable Time $\overline{\text{BE}}$ to Ax or Bx		1.5	8.3	

Notes:

1. See test circuit and waveforms.
2. This parameter is guaranteed but not tested on Propagation Delays.
3. The bus switch contributes no propagational delay other than the RC delay of the On-Resistance of the switch and the load capacitance. The time constant for the switch alone is of the order of 0.25ns for 50pF load. Since this time constant is much smaller than the rise/fall times of typical driving signals, it adds very little propagational delay to the system. Propagational delay of the bus switch when used in a system is determined by the driving circuit on the driving side of the switch and its interaction with the load on the driven side.

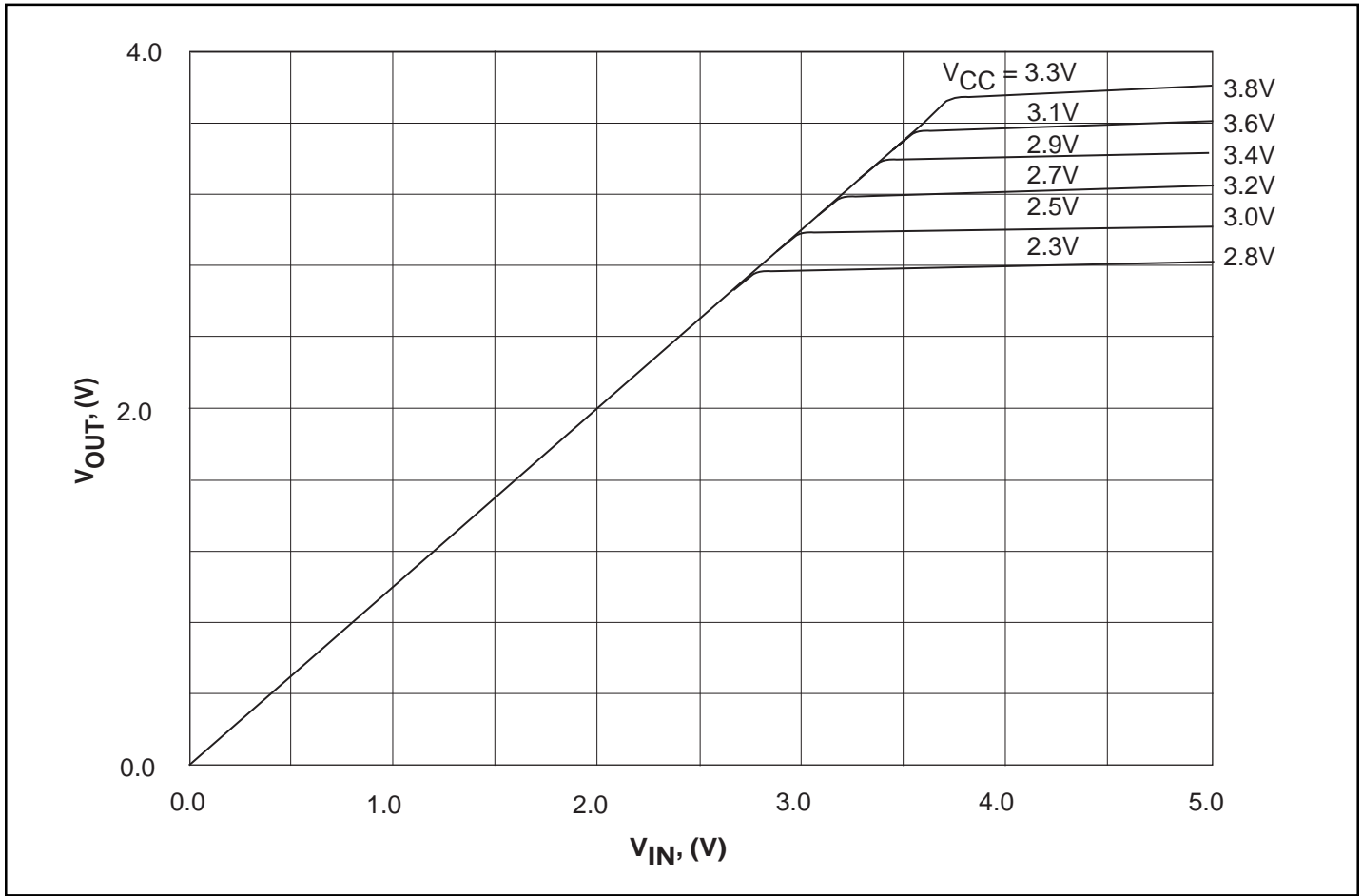

Output Voltage vs. Input Voltage over Various Supply Voltages

Packaging MEchanical: 80-pin 150-mil Wide Plastic BQSOP (B)

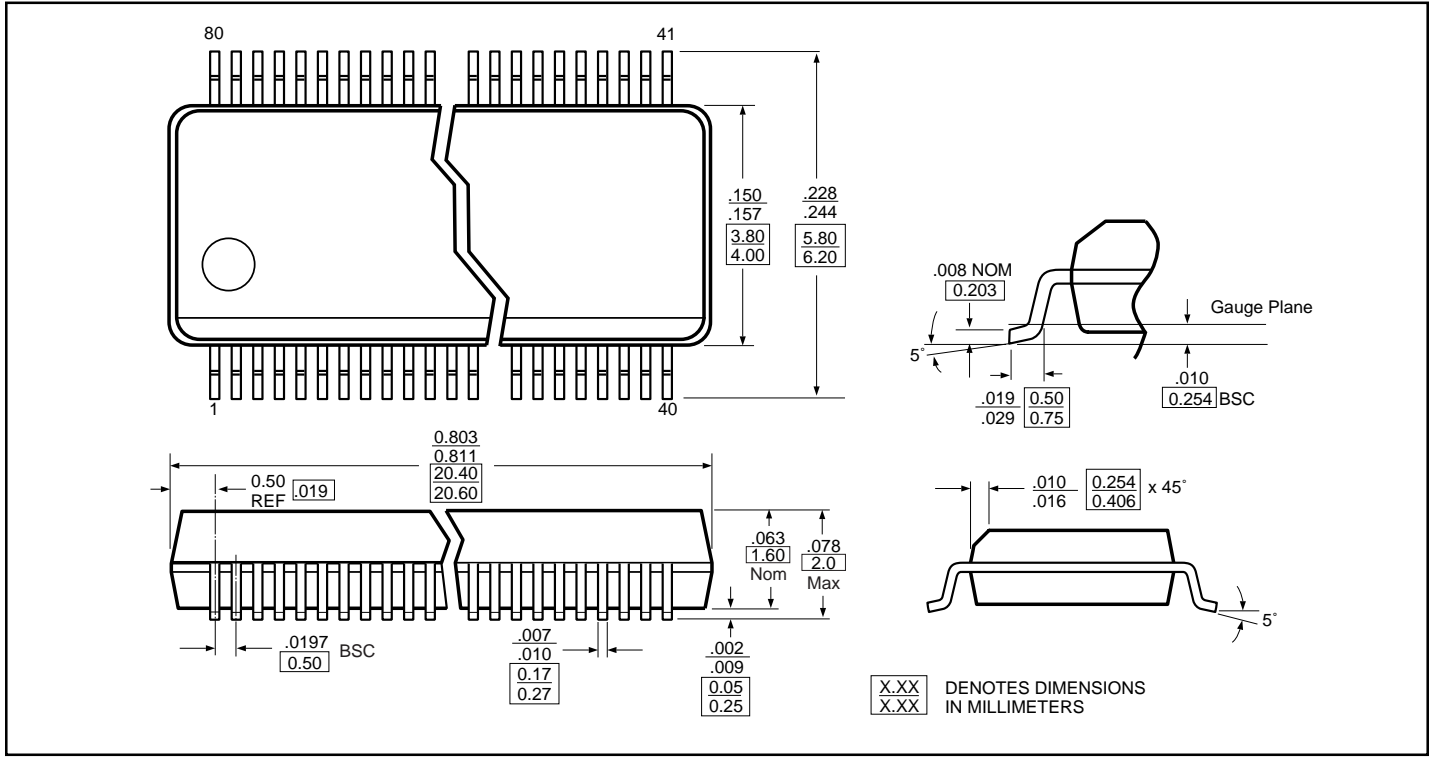

Ordering Information

Ordering Code	Package Code	Package Type
PI3C34X245B	B	80-pin BQSOP
PI3C34X245BE	B	Pb-free & Green, 80-pin BQSOP

Notes:

1. Thermal characteristics can be found on the company web site at www.pericom.com/packaging/