

To our customers,

Old Company Name in Catalogs and Other Documents

On April 1st, 2010, NEC Electronics Corporation merged with Renesas Technology Corporation, and Renesas Electronics Corporation took over all the business of both companies. Therefore, although the old company name remains in this document, it is a valid Renesas Electronics document. We appreciate your understanding.

Renesas Electronics website: <http://www.renesas.com>

April 1st, 2010
Renesas Electronics Corporation

Issued by: Renesas Electronics Corporation (<http://www.renesas.com>)

Send any inquiries to <http://www.renesas.com/inquiry>.

Notice

1. All information included in this document is current as of the date this document is issued. Such information, however, is subject to change without any prior notice. Before purchasing or using any Renesas Electronics products listed herein, please confirm the latest product information with a Renesas Electronics sales office. Also, please pay regular and careful attention to additional and different information to be disclosed by Renesas Electronics such as that disclosed through our website.
2. Renesas Electronics does not assume any liability for infringement of patents, copyrights, or other intellectual property rights of third parties by or arising from the use of Renesas Electronics products or technical information described in this document. No license, express, implied or otherwise, is granted hereby under any patents, copyrights or other intellectual property rights of Renesas Electronics or others.
3. You should not alter, modify, copy, or otherwise misappropriate any Renesas Electronics product, whether in whole or in part.
4. Descriptions of circuits, software and other related information in this document are provided only to illustrate the operation of semiconductor products and application examples. You are fully responsible for the incorporation of these circuits, software, and information in the design of your equipment. Renesas Electronics assumes no responsibility for any losses incurred by you or third parties arising from the use of these circuits, software, or information.
5. When exporting the products or technology described in this document, you should comply with the applicable export control laws and regulations and follow the procedures required by such laws and regulations. You should not use Renesas Electronics products or the technology described in this document for any purpose relating to military applications or use by the military, including but not limited to the development of weapons of mass destruction. Renesas Electronics products and technology may not be used for or incorporated into any products or systems whose manufacture, use, or sale is prohibited under any applicable domestic or foreign laws or regulations.
6. Renesas Electronics has used reasonable care in preparing the information included in this document, but Renesas Electronics does not warrant that such information is error free. Renesas Electronics assumes no liability whatsoever for any damages incurred by you resulting from errors in or omissions from the information included herein.
7. Renesas Electronics products are classified according to the following three quality grades: “Standard”, “High Quality”, and “Specific”. The recommended applications for each Renesas Electronics product depends on the product’s quality grade, as indicated below. You must check the quality grade of each Renesas Electronics product before using it in a particular application. You may not use any Renesas Electronics product for any application categorized as “Specific” without the prior written consent of Renesas Electronics. Further, you may not use any Renesas Electronics product for any application for which it is not intended without the prior written consent of Renesas Electronics. Renesas Electronics shall not be in any way liable for any damages or losses incurred by you or third parties arising from the use of any Renesas Electronics product for an application categorized as “Specific” or for which the product is not intended where you have failed to obtain the prior written consent of Renesas Electronics. The quality grade of each Renesas Electronics product is “Standard” unless otherwise expressly specified in a Renesas Electronics data sheets or data books, etc.
 - “Standard”: Computers; office equipment; communications equipment; test and measurement equipment; audio and visual equipment; home electronic appliances; machine tools; personal electronic equipment; and industrial robots.
 - “High Quality”: Transportation equipment (automobiles, trains, ships, etc.); traffic control systems; anti-disaster systems; anti-crime systems; safety equipment; and medical equipment not specifically designed for life support.
 - “Specific”: Aircraft; aerospace equipment; submersible repeaters; nuclear reactor control systems; medical equipment or systems for life support (e.g. artificial life support devices or systems), surgical implantations, or healthcare intervention (e.g. excision, etc.), and any other applications or purposes that pose a direct threat to human life.
8. You should use the Renesas Electronics products described in this document within the range specified by Renesas Electronics, especially with respect to the maximum rating, operating supply voltage range, movement power voltage range, heat radiation characteristics, installation and other product characteristics. Renesas Electronics shall have no liability for malfunctions or damages arising out of the use of Renesas Electronics products beyond such specified ranges.
9. Although Renesas Electronics endeavors to improve the quality and reliability of its products, semiconductor products have specific characteristics such as the occurrence of failure at a certain rate and malfunctions under certain use conditions. Further, Renesas Electronics products are not subject to radiation resistance design. Please be sure to implement safety measures to guard them against the possibility of physical injury, and injury or damage caused by fire in the event of the failure of a Renesas Electronics product, such as safety design for hardware and software including but not limited to redundancy, fire control and malfunction prevention, appropriate treatment for aging degradation or any other appropriate measures. Because the evaluation of microcomputer software alone is very difficult, please evaluate the safety of the final products or system manufactured by you.
10. Please contact a Renesas Electronics sales office for details as to environmental matters such as the environmental compatibility of each Renesas Electronics product. Please use Renesas Electronics products in compliance with all applicable laws and regulations that regulate the inclusion or use of controlled substances, including without limitation, the EU RoHS Directive. Renesas Electronics assumes no liability for damages or losses occurring as a result of your noncompliance with applicable laws and regulations.
11. This document may not be reproduced or duplicated, in any form, in whole or in part, without prior written consent of Renesas Electronics.
12. Please contact a Renesas Electronics sales office if you have any questions regarding the information contained in this document or Renesas Electronics products, or if you have any other inquiries.

(Note 1) “Renesas Electronics” as used in this document means Renesas Electronics Corporation and also includes its majority-owned subsidiaries.

(Note 2) “Renesas Electronics product(s)” means any product developed or manufactured by or for Renesas Electronics.

1M-BIT CMOS STATIC RAM

128K-WORD BY 8-BIT

Description

The μ PD431000A is a high speed, low power, and 1,048,576 bits (131,072 words by 8 bits) CMOS static RAM.

The μ PD431000A has two chip enable pins (/CE1, CE2) to extend the capacity. And battery backup is available. In addition to this, A and B versions are low voltage operations.

The μ PD431000A is packed in 32-pin PLASTIC SOP and 32-pin PLASTIC TSOP (I) (8 × 13.4 mm) and (8 × 20 mm).

Features

- 131,072 words by 8 bits organization
- Fast access time: 70, 85, 100, 120, 150 ns (MAX.)
- Low voltage operation (A version: $V_{CC} = 3.0$ to 5.5 V, B version: $V_{CC} = 2.7$ to 5.5 V)
- Operating ambient temperature: $T_A = 0$ to 70 °C
- Low V_{CC} data retention: 2.0 V (MIN.)
- Output Enable input for easy application
- Two Chip Enable inputs: /CE1, CE2

Part number	Access time ns (MAX.)	Operating supply voltage V	Operating ambient temperature °C	Supply current		
				At operating mA (MAX.)	At standby μ A (MAX.)	At data retention μ A (MAX.) ^{Note1}
μ PD431000A-xxL	70, 85	4.5 to 5.5	0 to 70	70	100	15
μ PD431000A-xxLL					20	3
μ PD431000A-Axx	70 ^{Note2} , 100	3.0 to 5.5		35 ^{Note3}	13 ^{Note5}	
μ PD431000A-Bxx	70 ^{Note2} , 100, 120, 150	2.7 to 5.5		30 ^{Note4}	11 ^{Note6}	

Notes 1. $T_A \leq 40$ °C

2. $V_{CC} = 4.5$ to 5.5 V
3. 70 mA ($V_{CC} > 3.6$ V)
4. 70 mA ($V_{CC} > 3.3$ V)
5. 20 μ A ($V_{CC} > 3.6$ V)
6. 20 μ A ($V_{CC} > 3.3$ V)

The information in this document is subject to change without notice. Before using this document, please confirm that this is the latest version.
Not all products and/or types are available in every country. Please check with an NEC Electronics sales representative for availability and additional information.

Ordering Information

(1/2)

Part number	Package	Access time ns (MAX.)	Operating supply voltage V	Operating ambient temperature °C	Remark
μPD431000AGW-70L	32-pin PLASTIC SOP (13.34 mm (525))	70	4.5 to 5.5	0 to 70	L version
μPD431000AGW-85L		85			
μPD431000AGW-70LL		70			LL version
μPD431000AGW-85LL		85			
μPD431000AGW-A10		100	3.0 to 5.5		A version
μPD431000AGW-B12		120	2.7 to 5.5		B version
μPD431000AGW-B15		150			
μPD431000AGZ-70LL-KJH	32-pin PLASTIC TSOP(I)	70	4.5 to 5.5		LL version
μPD431000AGZ-B15-KJH	(8x20) (Normal bent)	150	2.7 to 5.5		B version
μPD431000AGZ-70LL-KKH	32-pin PLASTIC TSOP(I) (8x20) (Reverse bent)	70	4.5 to 5.5		LL version
μPD431000AGU-B10-9JH	32-pin PLASTIC TSOP(I) (8x13.4) (Normal bent)	100	2.7 to 5.5		B version
μPD431000AGU-B12-9JH		120			
μPD431000AGU-B15-9JH		150			
μPD431000AGU-B10-9KH	32-pin PLASTIC TSOP(I) (8x13.4) (Reverse bent)	100			

(2/2)

Part number	Package	Access time ns (MAX.)	Operating supply voltage V	Operating ambient temperature °C	Remark
μPD431000AGW-70L-A	32-pin PLASTIC SOP (13.34 mm (525))	70	4.5 to 5.5	0 to 70	L version
μPD431000AGW-85L-A		85			
μPD431000AGW-70LL-A		70			LL version
μPD431000AGW-85LL-A		85			
μPD431000AGW-A10-A		100	3.0 to 5.5		A version
μPD431000AGW-B12-A		120	2.7 to 5.5		B version
μPD431000AGW-B15-A		150			
μPD431000AGZ-70LL-KJH-A	32-pin PLASTIC TSOP(I)	70	4.5 to 5.5		LL version
μPD431000AGZ-B10-KJH-A	(8x20) (Normal bent)	100	2.7 to 5.5		B version
μPD431000AGZ-70LL-KKH-A	32-pin PLASTIC TSOP(I) (8x20) (Reverse bent)	70	4.5 to 5.5		LL version
μPD431000AGU-B10-9JH-A	32-pin PLASTIC TSOP(I) (8x13.4) (Normal bent)	100	2.7 to 5.5		B version
μPD431000AGU-B12-9JH-A		120			
μPD431000AGU-B15-9JH-A		150			
μPD431000AGU-B10-9KH-A		100			
	32-pin PLASTIC TSOP(I) (8x13.4) (Reverse bent)				

Remark Products with -A at the end of the part number are lead-free products.

Pin Configurations (Marking Side)

/xxx indicates active low signal.

32-pin PLASTIC SOP (13.34 mm (525))

[μPD431000AGW-xxL]

[μPD431000AGW-xxLL]

[μPD431000AGW-Axx]

[μPD431000AGW-Bxx]

[μPD431000AGW-xxL-A]

[μPD431000AGW-xxLL-A]

[μPD431000AGW-Axx-A]

[μPD431000AGW-Bxx-A]

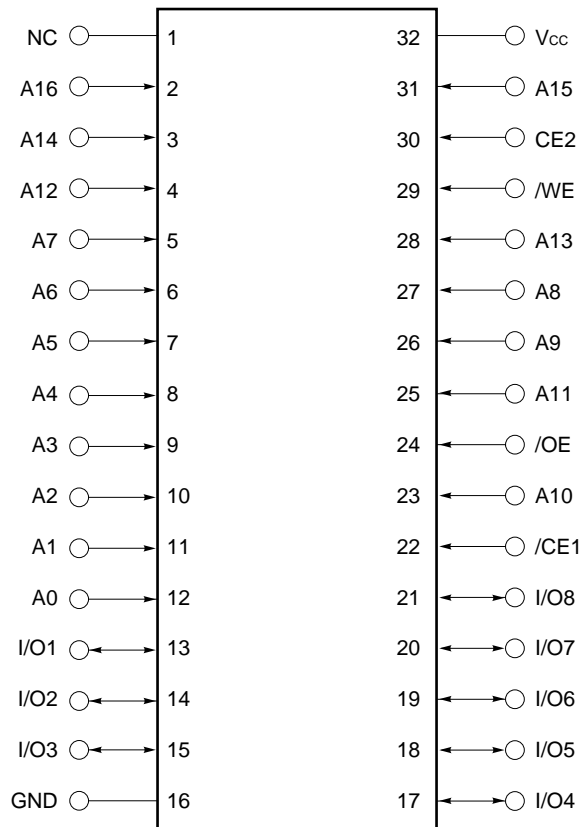

- A0 - A16 : Address inputs
- I/O1 - I/O8 : Data inputs / outputs
- /CE1, CE2 : Chip Enable 1, 2
- /WE : Write Enable
- /OE : Output Enable
- Vcc : Power supply
- GND : Ground
- NC : No connection

Remark Refer to **Package Drawings** for the 1-pin index mark.

32-pin PLASTIC TSOP(I) (8x20) (Normal bent)

[μPD431000AGZ-xxLL-KJH]

[μPD431000AGZ-Bxx-KJH]

[μPD431000AGZ-xxLL-KJH-A]

[μPD431000AGZ-Bxx-KJH-A]

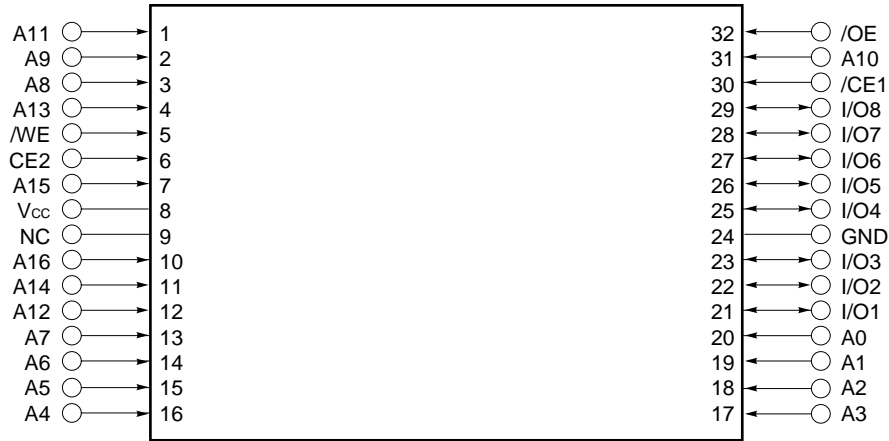

32-pin PLASTIC TSOP(I) (8x20) (Reverse bent)

[μPD431000AGZ-xxLL-KKH]

[μPD431000AGZ-xxLL-KKH-A]

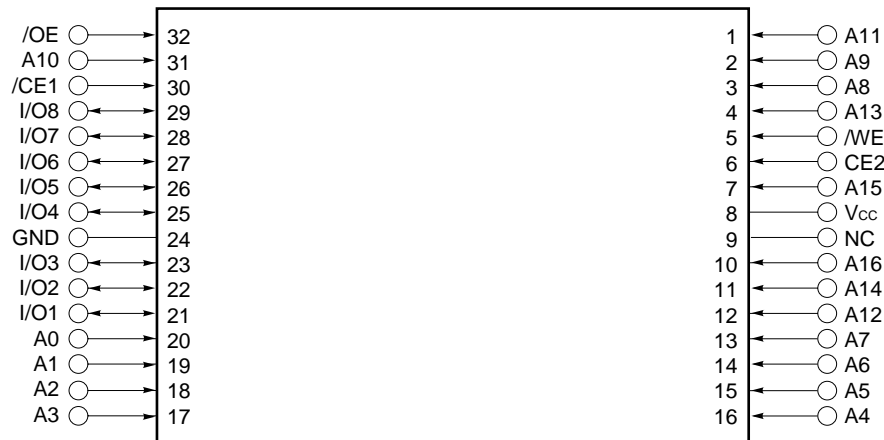

- | | |
|------------------------------------|--------------------------------|
| A0 - A16 : Address inputs | /OE : Output Enable |
| I/O1 - I/O8: Data inputs / outputs | V _{cc} : Power supply |
| /CE1, CE2: Chip Enable 1, 2 | GND: Ground |
| /WE : Write Enable | NC : No connection |

Remark Refer to **Package Drawings** for the 1-pin index mark.

32-pin PLASTIC TSOP(I) (8x13.4) (Normal bent)

[μPD431000AGU-Bxx-9JH]

[μPD431000AGU-Bxx-9JH-A]

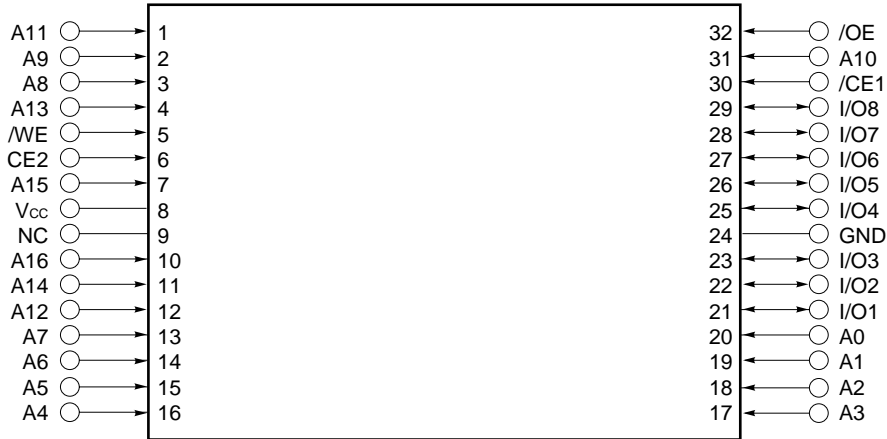

32-pin PLASTIC TSOP(I) (8x13.4) (Reverse bent)

[μPD431000AGU-Bxx-9KH]

[μPD431000AGU-Bxx-9KH-A]



- A0 - A16 : Address inputs
- I/O1 - I/O8 : Data inputs / outputs
- /CE1, CE2 : Chip Enable 1, 2
- /WE : Write Enable
- /OE : Output Enable
- Vcc : Power supply
- GND : Ground
- NC : No connection

Remark Refer to **Package Drawings** for the 1-pin index mark.

Block Diagram

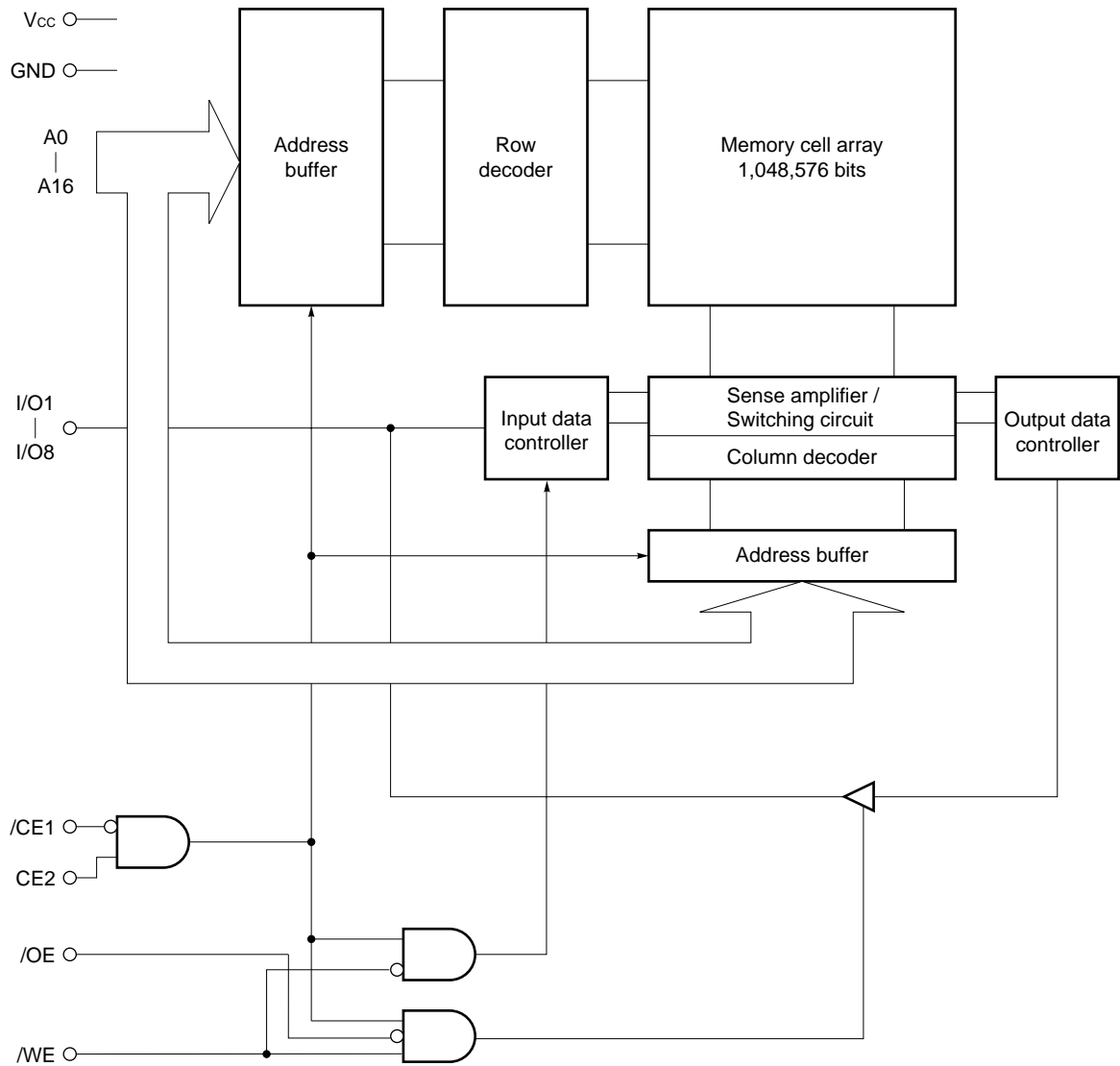

Truth Table

/CE1	CE2	/OE	/WE	Mode	I/O	Supply current
H	×	×	×	Not selected	High impedance	I _{SB}
×	L	×	×			
L	H	H	H	Output disable		I _{CCA}
L	H	L	H	Read	D _{OUT}	
L	H	×	L	Write	D _{IN}	

Remark × : V_{IH} or V_{IL}

Electrical Specifications

Absolute Maximum Ratings

Parameter	Symbol	Condition	Rating	Unit
Supply voltage	V _{CC}		-0.5 ^{Note} to +7.0	V
Input / Output voltage	V _T		-0.5 ^{Note} to V _{CC} + 0.5	V
Operating ambient temperature	T _A		0 to 70	°C
Storage temperature	T _{stg}		-55 to +125	°C

Note -3.0 V (MIN.) (Pulse width: 30 ns)

Caution Exposing the device to stress above those listed in Absolute Maximum Rating could cause permanent damage. The device is not meant to be operated under conditions outside the limits described in the operational section of this specification. Exposure to Absolute Maximum Rating conditions for extended periods may affect device reliability.

Recommended Operating Conditions

Parameter	Symbol	Condition	μPD431000A-xxL		μPD431000A-Axx		μPD431000A-Bxx		Unit
			MIN.	MAX.	MIN.	MAX.	MIN.	MAX.	
Supply voltage	V _{CC}		4.5	5.5	3.0	5.5	2.7	5.5	V
High level input voltage	V _{IH}		2.2	V _{CC} +0.5	2.2	V _{CC} +0.5	2.2	V _{CC} +0.5	V
Low level input voltage	V _{IL}		-0.3 ^{Note}	+0.8	-0.3 ^{Note}	+0.5	-0.3 ^{Note}	+0.5	V
Operating ambient temperature	T _A		0	70	0	70	0	70	°C

Note -3.0 V (MIN.) (Pulse width: 30 ns)

Capacitance (T_A = 25 °C, f = 1 MHz)

Parameter	Symbol	Test conditions	MIN.	TYP.	MAX.	Unit
Input capacitance	C _{IN}	V _{IN} = 0 V			6	pF
Input / Output capacitance	C _{I/O}	V _{I/O} = 0 V			10	pF

- Remarks**
1. V_{IN} : Input voltage
V_{I/O} : Input / Output voltage
 2. These parameters are not 100% tested.

DC Characteristics (Recommended Operating Conditions Unless Otherwise Noted) (1/2)

Parameter	Symbol	Test condition	μPD431000A-xxL			μPD431000A-xxLL			μPD431000A-Axx			Unit
			MIN.	TYP.	MAX.	MIN.	TYP.	MAX.	MIN.	TYP.	MAX.	
Input leakage current	I _{LI}	V _{IN} = 0 V to V _{CC}	-1.0		+1.0	-1.0		+1.0	-1.0		+1.0	μA
I/O leakage current	I _{LO}	V _{I/O} = 0 V to V _{CC} , /CE1 = V _{IH} or CE2 = V _{IL} or /WE = V _{IL} or /OE = V _{IH}	-1.0		+1.0	-1.0		+1.0	-1.0		+1.0	μA
Operating supply current	I _{CCA1}	/CE1 = V _{IL} , CE2 = V _{IH} , I _{I/O} = 0 mA		40	70		40	70		40	70	mA
		Minimum cycle time V _{CC} ≤ 3.6 V			-			-			35	
	I _{CCA2}	/CE1 = V _{IL} , CE2 = V _{IH} , I _{I/O} = 0 mA, Cycle time = ∞			15			15			15	
		V _{CC} ≤ 3.6 V			-			-			8	
I _{CCA3}	/CE1 ≤ 0.2 V, CE2 ≥ V _{CC} - 0.2 V, Cycle time = 1 μs, I _{I/O} = 0 mA, V _{IL} ≤ 0.2 V, V _{IH} ≥ V _{CC} - 0.2 V			10			10			10		
	V _{CC} ≤ 3.6 V			-			-			8		
Standby supply current	I _{SB}	/CE1 = V _{IH} or CE2 = V _{IL}			3			3			3	mA
		V _{CC} ≤ 3.6 V			-			-			2	
	I _{SB1}	/CE1 ≥ V _{CC} - 0.2 V, CE2 ≥ V _{CC} - 0.2 V		2	100		1	20		1	20	μA
		V _{CC} ≤ 3.6 V			-			-		0.5	13	
I _{SB2}	CE2 ≤ 0.2 V		2	100		1	20		1	20		
	V _{CC} ≤ 3.6 V			-			-		0.5	13		
High level output voltage	V _{OH1}	I _{OH} = -1.0 mA, V _{CC} ≥ 4.5 V	2.4			2.4			2.4			V
		I _{OH} = -0.5 mA	-			-			2.4			
	V _{OH2}	I _{OH} = -0.02 mA	-			-			V _{CC} -0.1			
Low level output voltage	V _{OL1}	I _{OL} = 2.1 mA, V _{CC} ≥ 4.5 V			0.4			0.4			0.4	V
		I _{OL} = 1.0 mA			-			-			0.4	
	V _{OL2}	I _{OL} = 0.02 mA			-			-			0.1	

Remarks 1. V_{IN} : Input voltage

V_{I/O} : Input / Output voltage

2. These DC characteristics are in common regardless product classification.

DC Characteristics (Recommended Operating Conditions Unless Otherwise Noted) (2/2)

Parameter	Symbol	Test condition	μPD431000A-Bxx			Unit	
			MIN.	TYP.	MAX.		
Input leakage current	I _{LI}	V _{IN} = 0 V to V _{CC}	-1.0		+1.0	μA	
I/O leakage current	I _{LO}	V _{I/O} = 0 V to V _{CC} , /CE1 = V _{IH} or CE2 = V _{IL} or /WE = V _{IL} or /OE = V _{IH}	-1.0		+1.0	μA	
Operating supply current	I _{CCA1}	/CE1 = V _{IL} , CE2 = V _{IH} , I _{I/O} = 0 mA		40	70	mA	
		Minimum cycle time	V _{CC} ≤ 3.3 V		30		
	I _{CCA2}	/CE1 = V _{IL} , CE2 = V _{IH} , I _{I/O} = 0 mA,			15		
		Cycle time = ∞	V _{CC} ≤ 3.3 V		7		
	I _{CCA3}	/CE1 ≤ 0.2 V, CE2 ≥ V _{CC} - 0.2 V,			10		
		Cycle time = 1 μs, I _{I/O} = 0 mA, V _{IL} ≤ 0.2 V, V _{IH} ≥ V _{CC} - 0.2 V	V _{CC} ≤ 3.3 V		7		
Standby supply current	I _{SB}	/CE1 = V _{IH} or CE2 = V _{IL}			3	mA	
			V _{CC} ≤ 3.3 V		2		
	I _{SB1}	/CE1 ≥ V _{CC} - 0.2 V, CE2 ≥ V _{CC} - 0.2 V		1	20	μA	
			V _{CC} ≤ 3.3 V	0.5	11		
		I _{SB2}	CE2 ≤ 0.2 V		1		20
				V _{CC} ≤ 3.3 V	0.5		11
High level output voltage	V _{OH1}	I _{OH} = -1.0 mA, V _{CC} ≥ 4.5 V	2.4			V	
		I _{OH} = -0.5 mA	2.4				
	V _{OH2}	I _{OH} = -0.02 mA	V _{CC} -0.1				
Low level output voltage	V _{OL1}	I _{OL} = 2.1 mA, V _{CC} ≥ 4.5 V			0.4	V	
		I _{OL} = 1.0 mA			0.4		
	V _{OL2}	I _{OL} = 0.02 mA			0.1		

Remarks 1. V_{IN} : Input voltage

V_{I/O} : Input / Output voltage

2. These DC characteristics are in common regardless product classification.

AC Characteristics (Recommended Operating Conditions Unless Otherwise Noted)

AC Test Conditions

[μPD431000A-70L, μPD431000A-85L, μPD431000A-70LL, μPD431000A-85LL]

Input Waveform (Rise and Fall Time ≤ 5 ns)

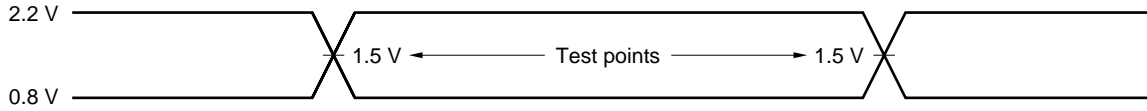

Output Waveform

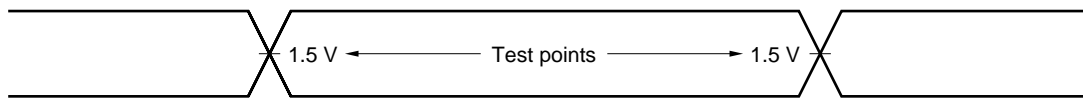

Output Load

AC characteristics should be measured with the following output load conditions.

Figure 1

(tAA, tCO1, tCO2, tOE, tOH)

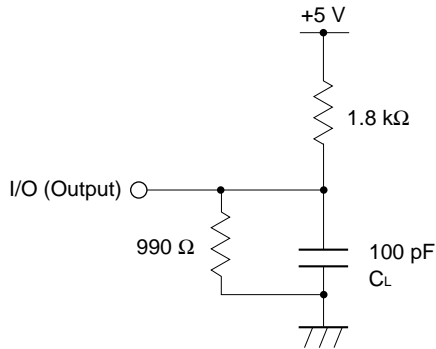
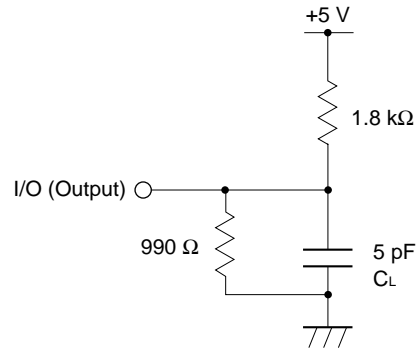

Figure 2

(tLZ1, tLZ2, tOLZ, tHZ1, tHZ2, tOHZ, tWHZ, tOW)



Remark CL includes capacitance of the probe and jig, and stray capacitance.

[μPD431000A-A10, μPD431000A-B10, μPD431000A-B12, μPD431000A-B15]

Input Waveform (Rise and Fall Time ≤ 5 ns)

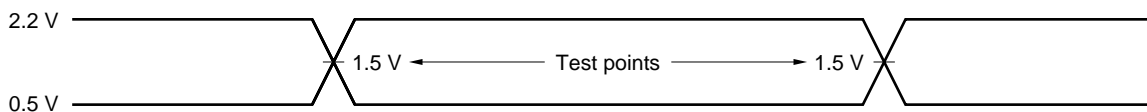

Output Waveform

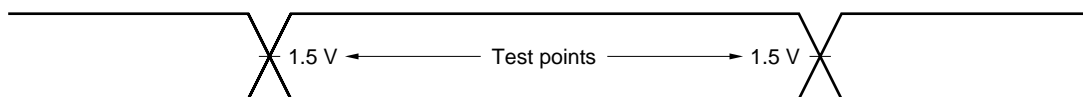

Output Load

AC characteristics should be measured with the following output load conditions.

Part number	Output load condition	
	tAA, tCO1, tCO2, tOE, tOH	tLZ1, tLZ2, tOLZ, tHZ1, tHZ2, tOHZ, tWHZ, tOW
μPD431000A-A10, μPD431000A-B10, μPD431000A-B12	1TTL + 50 pF	1TTL + 5 pF
μPD431000A-B15	1TTL + 100 pF	1TTL + 5 pF

Read Cycle (1/2)

Parameter	Symbol	V _{CC} ≥ 4.5 V				V _{CC} ≥ 3.0 V		Unit	Condition
		μPD431000A-70 μPD431000A-Axx μPD431000A-Bxx		μPD431000A-85		μPD431000A-A10			
		MIN.	MAX.	MIN.	MAX.	MIN.	MAX.		
Read cycle time	t _{RC}	70		85		100		ns	
Address access time	t _{AA}		70		85		100	ns	Note
/CE1 access time	t _{CO1}		70		85		100	ns	
CE2 access time	t _{CO2}		70		85		100	ns	
/OE to output valid	t _{OE}		35		45		50	ns	
Output hold from address change	t _{OH}	10		10		10		ns	
/CE1 to output in low impedance	t _{LZ1}	10		10		10		ns	
CE2 to output in low impedance	t _{LZ2}	10		10		10		ns	
/OE to output in low impedance	t _{OLZ}	5		5		5		ns	
/CE1 to output in high impedance	t _{HZ1}		25		30		35	ns	
CE2 to output in high impedance	t _{HZ2}		25		30		35	ns	
/OE to output in high impedance	t _{OHZ}		25		30		35	ns	

Note See the output load.

Remark These AC characteristics are in common regardless of package types.

Read Cycle (2/2)

Parameter	Symbol	V _{CC} ≥ 2.7 V						Unit	Condition
		μPD431000A-B10		μPD431000A-B12		μPD431000A-B15			
		MIN.	MAX.	MIN.	MAX.	MIN.	MAX.		
Read cycle time	t _{RC}	100		120		150		ns	
Address access time	t _{AA}		100		120		150	ns	Note
/CE1 access time	t _{CO1}		100		120		150	ns	
CE2 access time	t _{CO2}		100		120		150	ns	
/OE to output valid	t _{OE}		50		60		70	ns	
Output hold from address change	t _{OH}	10		10		10		ns	
/CE1 to output in low impedance	t _{LZ1}	10		10		10		ns	
CE2 to output in low impedance	t _{LZ2}	10		10		10		ns	
/OE to output in low impedance	t _{OLZ}	5		5		5		ns	
/CE1 to output in high impedance	t _{HZ1}		35		40		50	ns	
CE2 to output in high impedance	t _{HZ2}		35		40		50	ns	
/OE to output in high impedance	t _{OHZ}		35		40		50	ns	

Note See the output load.

Remark These AC characteristics are in common regardless of package types.

Read Cycle Timing Chart

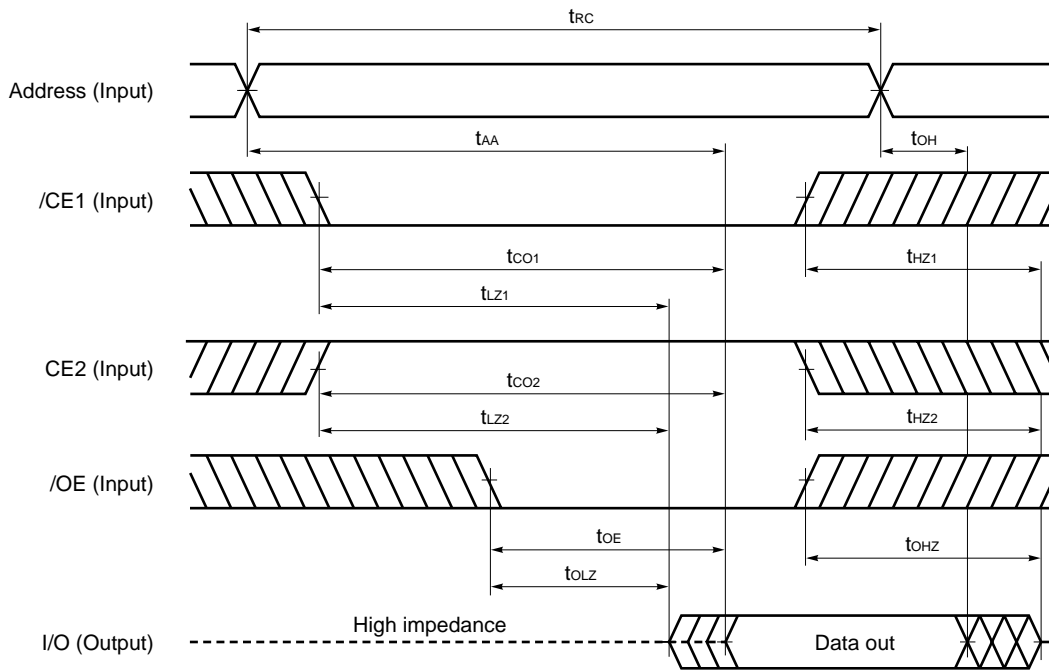

Remark In read cycle, /WE should be fixed to high level.

Write Cycle (1/2)

Parameter	Symbol	V _{CC} ≥ 4.5 V				V _{CC} ≥ 3.0 V		Unit	Condition
		μPD431000A-70 μPD431000A-Axx μPD431000A-Bxx		μPD431000A-85		μPD431000A-A10			
		MIN.	MAX.	MIN.	MAX.	MIN.	MAX.		
Write cycle time	t _{wc}	70		85		100		ns	
/CE1 to end of write	t _{cw1}	55		70		80		ns	
CE2 to end of write	t _{cw2}	55		70		80		ns	
Address valid to end of write	t _{aw}	55		70		80		ns	
Address setup time	t _{as}	0		0		0		ns	
Write pulse width	t _{wp}	50		60		60		ns	
Write recovery time	t _{wr}	5		5		0		ns	
Data valid to end of write	t _{dw}	35		35		60		ns	
Data hold time	t _{dh}	0		0		0		ns	
/WE to output in high impedance	t _{whz}		25		30		35	ns	Note
Output active from end of write	t _{ow}	5		5		5		ns	

Note See the **output load**.

Remark These AC characteristics are in common regardless package types.

Write Cycle (2/2)

Parameter	Symbol	V _{CC} ≥ 2.7 V						Unit	Condition
		μPD431000A-B10		μPD431000A-B12		μPD431000A-B15			
		MIN.	MAX.	MIN.	MAX.	MIN.	MAX.		
Write cycle time	t _{wc}	100		120		150		ns	
/CE1 to end of write	t _{cw1}	80		100		120		ns	
CE2 to end of write	t _{cw2}	80		100		120		ns	
Address valid to end of write	t _{aw}	80		100		120		ns	
Address setup time	t _{as}	0		0		0		ns	
Write pulse width	t _{wp}	60		85		100		ns	
Write recovery time	t _{wr}	0		0		0		ns	
Data valid to end of write	t _{dw}	60		60		80		ns	
Data hold time	t _{dh}	0		0		0		ns	
/WE to output in high impedance	t _{whz}		35		40		50	ns	Note
Output active from end of write	t _{ow}	5		5		5		ns	

Note See the **output load**.

Remark These AC characteristics are in common regardless of package types.

Write Cycle Timing Chart 1 (/WE Controlled)

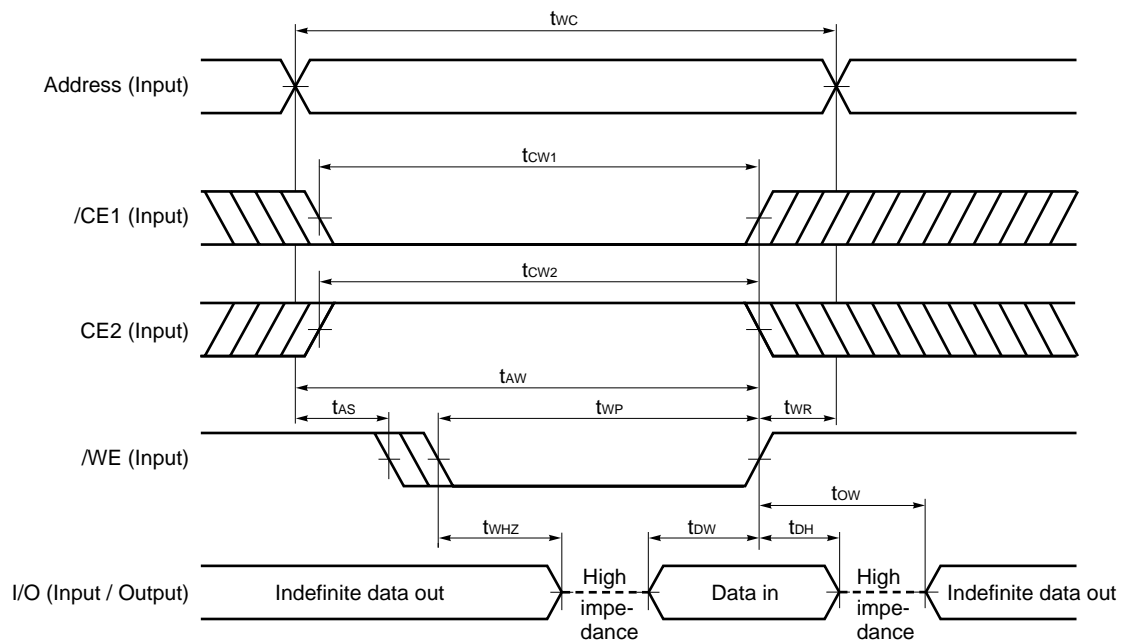

- Cautions**
1. During address transition, at least one of pins /CE1, CE2, /WE should be inactivated.
 2. Do not input data to the I/O pins while they are in the output state.

- Remarks**
1. Write operation is done during the overlap time of a low level /CE1, /WE and a high level CE2.
 2. If /CE1 changes to low level at the same time or after the change of /WE to low level, or if CE2 changes to high level at the same time or after the change of /WE to low level, the I/O pins will remain high impedance state.
 3. When /WE is at low level, the I/O pins are always high impedance. When /WE is at high level, read operation is executed. Therefore /OE should be at high level to make the I/O pins high impedance.

Write Cycle Timing Chart 2 (/CE1 Controlled)

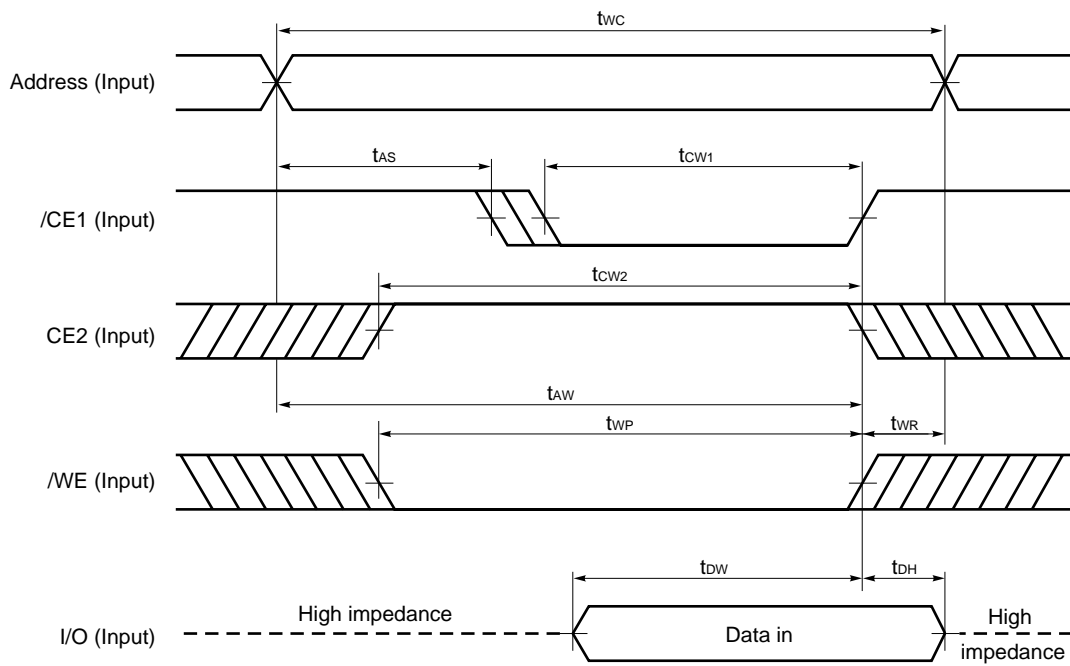

- Cautions**
1. During address transition, at least one of pins $\overline{CE1}$, CE2, \overline{WE} should be inactivated.
 2. Do not input data to the I/O pins while they are in the output state.

Remark Write operation is done during the overlap time of a low level $\overline{CE1}$, \overline{WE} and a high level CE2.

Write Cycle Timing Chart 3 (CE2 Controlled)

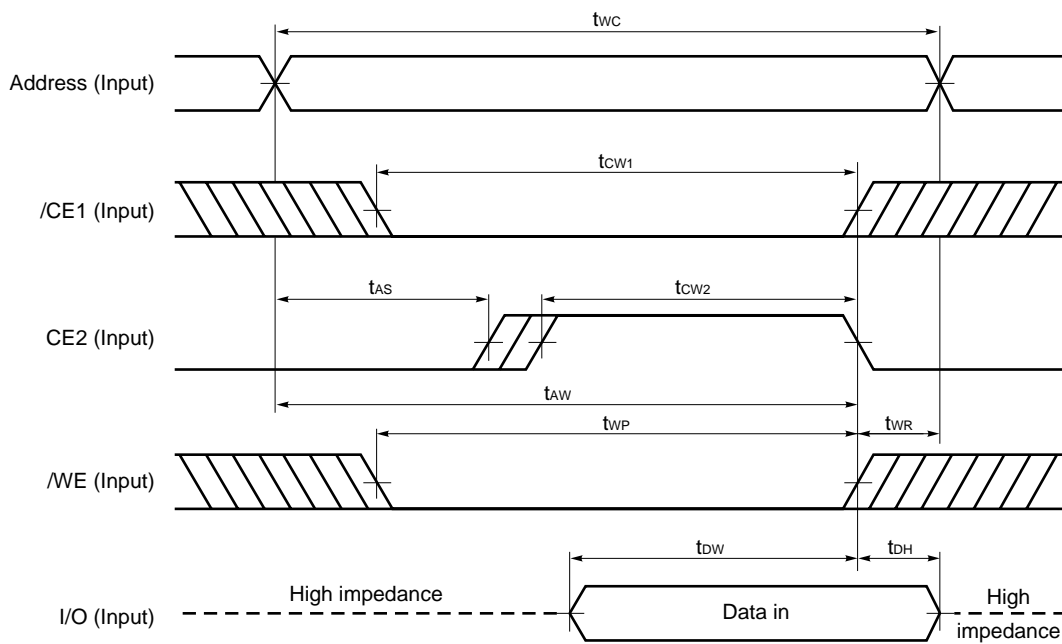

- Cautions**
1. During address transition, at least one of pins /CE1, CE2, /WE should be inactivated.
 2. Do not input data to the I/O pins while they are in the output state.

Remark Write operation is done during the overlap time of a low level /CE1, /WE and a high level CE2.

Low V_{CC} Data Retention Characteristics (T_A = 0 to 70 °C)

Parameter	Symbol	Test Condition	μPD431000A-xxL			μPD431000A-xxLL μPD431000A-Axx μPD431000A-Bxx			Unit
			MIN.	TYP.	MAX.	MIN.	TYP.	MAX.	
Data retention supply voltage	V _{CCDR1}	/CE1 ≥ V _{CC} – 0.2 V, CE2 ≥ V _{CC} – 0.2 V	2.0		5.5	2.0		5.5	V
	V _{CCDR2}	CE2 ≤ 0.2 V	2.0		5.5	2.0		5.5	
Data retention supply current	I _{CCDR1}	V _{CC} = 3.0 V, /CE1 ≥ V _{CC} – 0.2 V, CE2 ≥ V _{CC} – 0.2 V		1	50 ^{Note1}		0.5	10 ^{Note2}	μA
	I _{CCDR2}	V _{CC} = 3.0 V, CE2 ≤ 0.2 V		1	50 ^{Note1}		0.5	10 ^{Note2}	
Chip deselection to data retention mode	t _{CDR}		0			0			ns
Operation recovery time	t _R		5			5			ms

Notes 1. 15 μA (T_A ≤ 40 °C)

2. 3 μA (T_A ≤ 40 °C)

Data Retention Timing Chart

(1) /CE1 Controlled

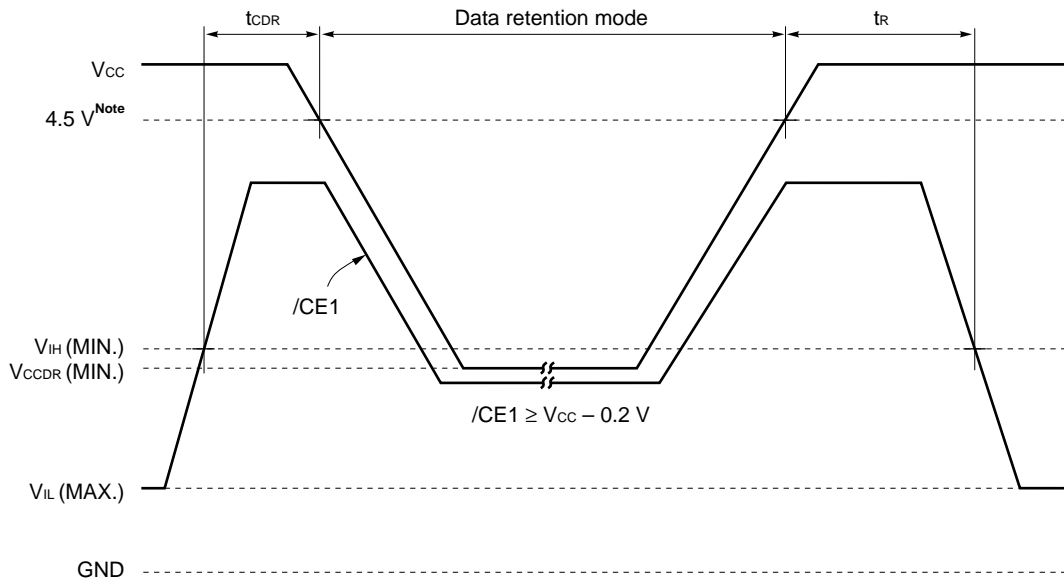

Note A version : 3.0 V, B version : 2.7 V

Remark On the data retention mode by controlling $\overline{CE1}$, the input level of CE2 must be $CE2 \geq V_{CC} - 0.2\text{ V}$ or $CE2 \leq 0.2\text{ V}$. The other pins (Address, I/O, \overline{WE} , \overline{OE}) can be in high impedance state.

(2) CE2 Controlled

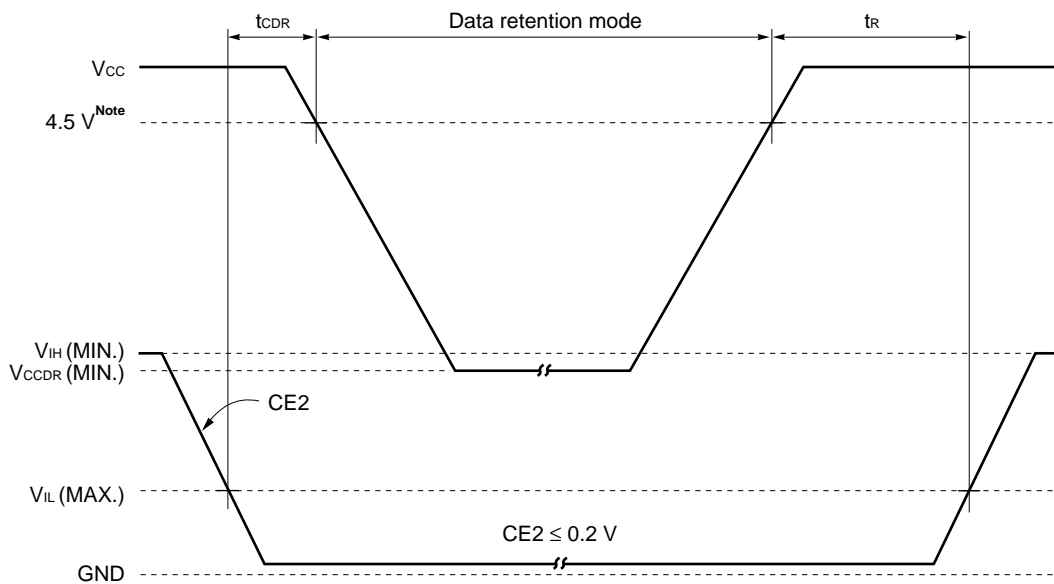

Note A version : 3.0 V, B version : 2.7 V

Remark On the data retention mode by controlling CE2, the other pins ($\overline{CE1}$, Address, I/O, \overline{WE} , \overline{OE}) can be in high impedance state.

Package Drawings

32-PIN PLASTIC SOP (13.34 mm (525))

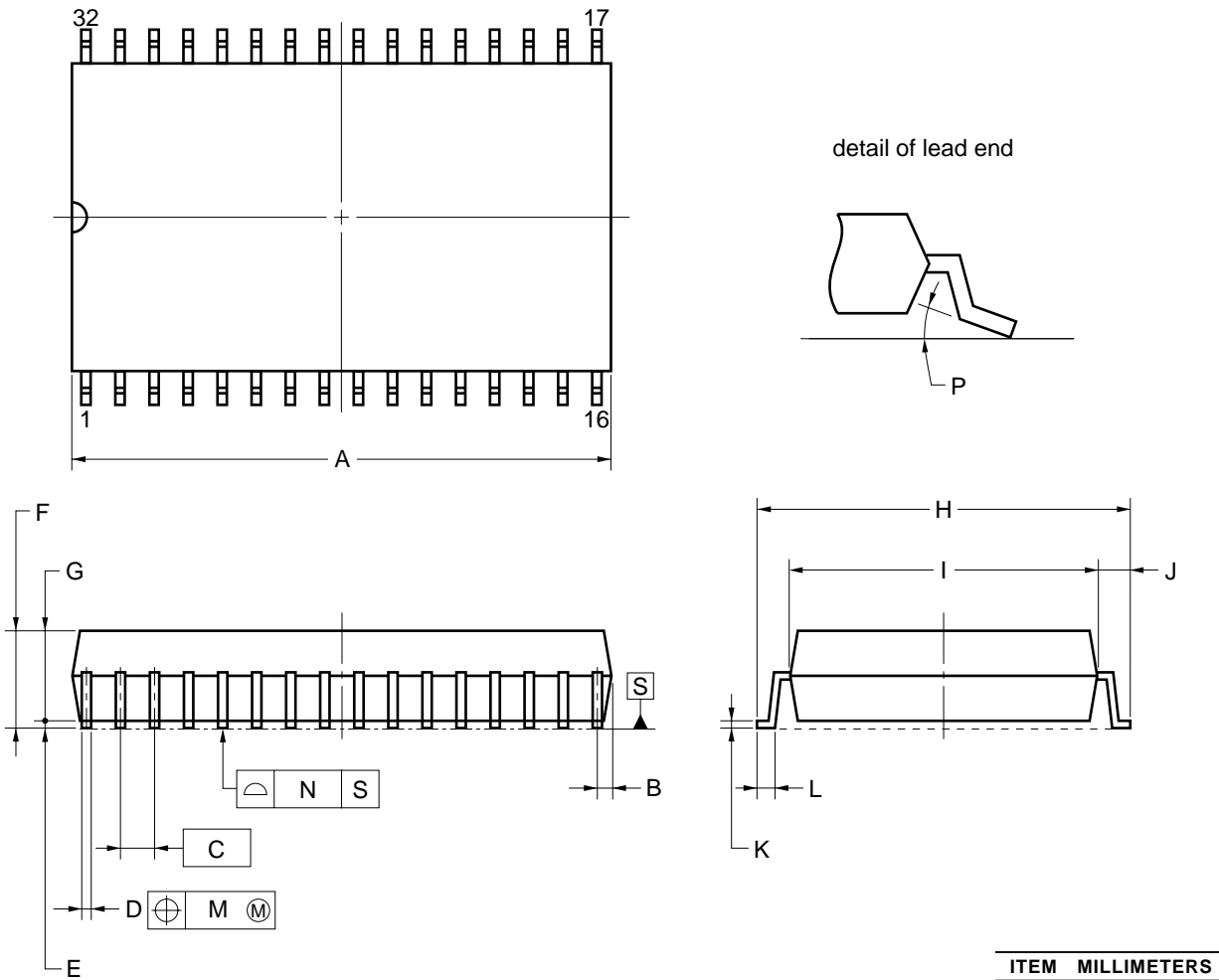

NOTE
 Each lead centerline is located within 0.12 mm of its true position (T.P.) at maximum material condition.

ITEM	MILLIMETERS
A	20.61 MAX.
B	0.78 MAX.
C	1.27 (T.P.)
D	0.40 ^{+0.10} _{-0.05}
E	0.15±0.05
F	2.95 MAX.
G	2.7
H	14.1±0.3
I	11.3
J	1.4±0.2
K	0.20 ^{+0.10} _{-0.05}
L	0.8±0.2
M	0.12
N	0.10
P	3° ^{+7°} _{-3°}

P32GW-50-525A-1

32-PIN PLASTIC TSOP(I) (8x20)

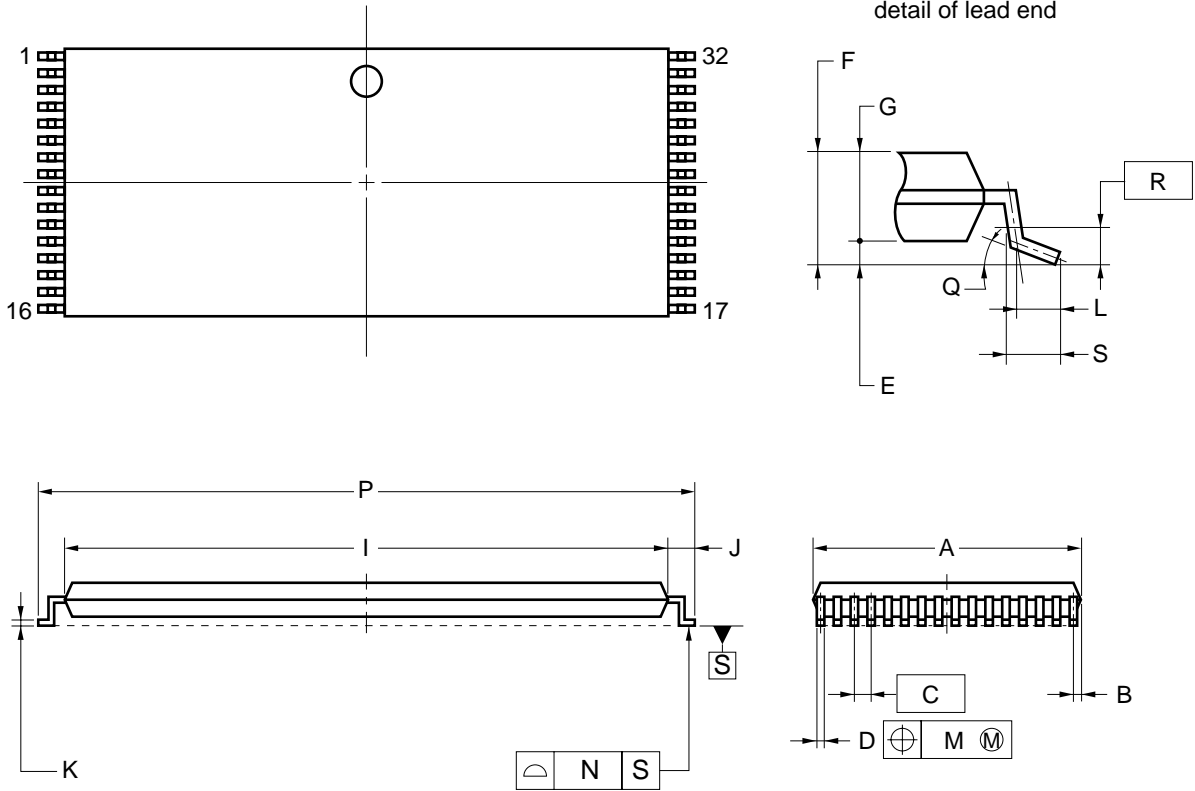

NOTES

1. Each lead centerline is located within 0.10 mm of its true position (T.P.) at maximum material condition.
2. "A" excludes mold flash. (Includes mold flash : 8.3 mm MAX.)

ITEM	MILLIMETERS
A	8.0±0.1
B	0.45 MAX.
C	0.5 (T.P.)
D	0.22±0.05
E	0.1±0.05
F	1.2 MAX.
G	0.97±0.08
I	18.4±0.1
J	0.8±0.2
K	0.145±0.05
L	0.5
M	0.10
N	0.10
P	20.0±0.2
Q	3° ^{+5°} -3°
R	0.25
S	0.60±0.15

S32GZ-50-KJH1-2

32-PIN PLASTIC TSOP(I) (8x20)

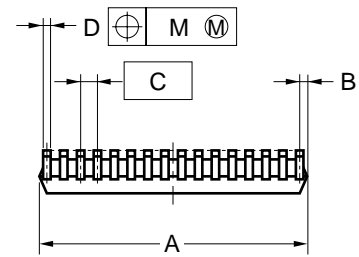
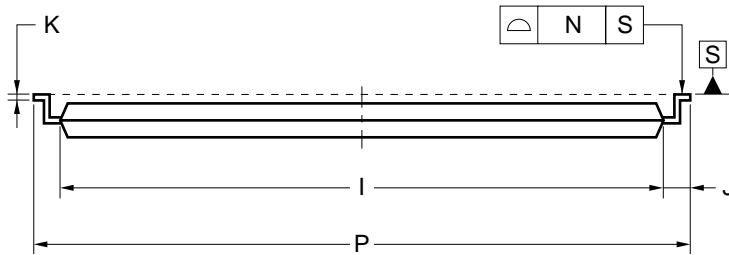
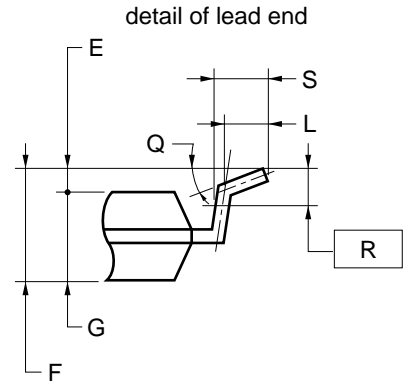
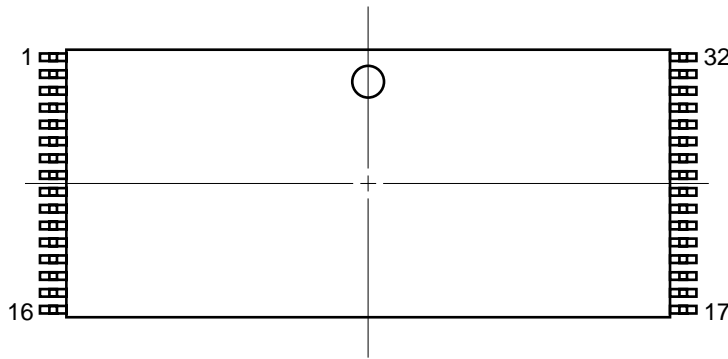

NOTES

1. Each lead centerline is located within 0.10 mm of its true position (T.P.) at maximum material condition.
2. "A" excludes mold flash. (Includes mold flash : 8.3 mm MAX.)

ITEM	MILLIMETERS
A	8.0±0.1
B	0.45 MAX.
C	0.5 (T.P.)
D	0.22±0.05
E	0.1±0.05
F	1.2 MAX.
G	0.97±0.08
I	18.4±0.1
J	0.8±0.2
K	0.145±0.05
L	0.5
M	0.10
N	0.10
P	20.0±0.2
Q	3°+5° -3°
R	0.25
S	0.60±0.15

S32GZ-50-KKH1-2

32-PIN PLASTIC TSOP(I) (8x13.4)

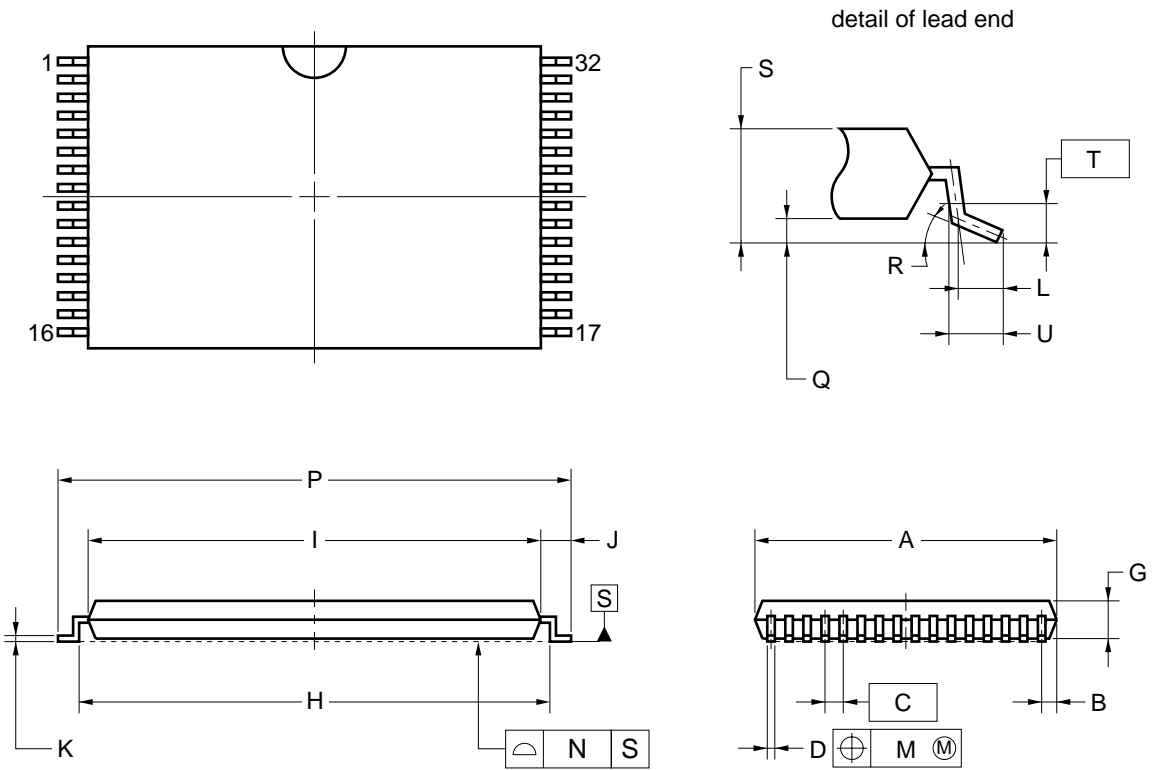

NOTES

1. Each lead centerline is located within 0.08 mm of its true position (T.P.) at maximum material condition.
2. "A" excludes mold flash. (Includes mold flash : 8.3 mm MAX.)

ITEM	MILLIMETERS
A	8.0±0.1
B	0.45 MAX.
C	0.5 (T.P.)
D	0.22±0.05
G	1.0±0.05
H	12.4±0.2
I	11.8±0.1
J	0.8±0.2
K	0.145 ^{+0.025} _{-0.015}
L	0.5
M	0.08
N	0.08
P	13.4±0.2
Q	0.1±0.05
R	3° ^{+5°} _{-3°}
S	1.2 MAX.
T	0.25
U	0.6±0.15

P32GU-50-9JH-2

32-PIN PLASTIC TSOP(I) (8x13.4)

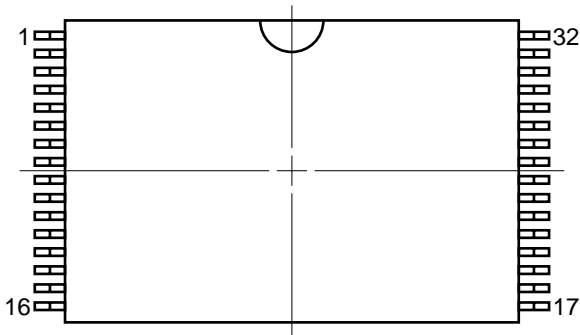

detail of lead end

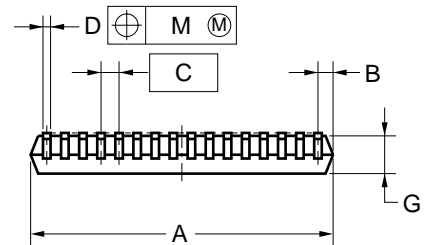
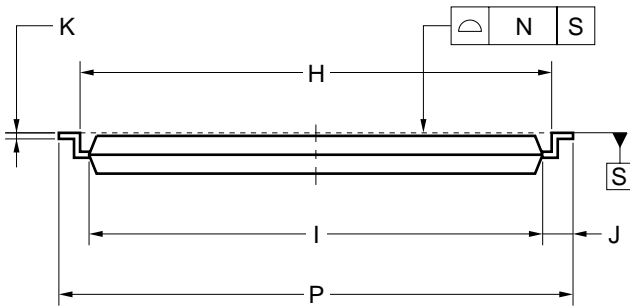
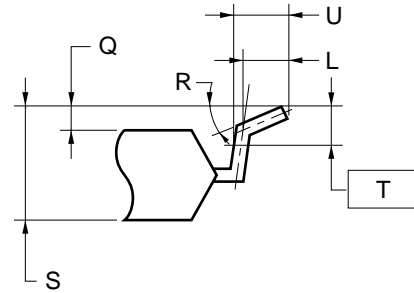

NOTES

1. Each lead centerline is located within 0.08 mm of its true position (T.P.) at maximum material condition.
2. "A" excludes mold flash. (Includes mold flash : 8.3 mm MAX.)

ITEM	MILLIMETERS
A	8.0±0.1
B	0.45 MAX.
C	0.5 (T.P.)
D	0.22±0.05
G	1.0±0.05
H	12.4±0.2
I	11.8±0.1
J	0.8±0.2
K	0.145 ^{+0.025} _{-0.015}
L	0.5
M	0.08
N	0.08
P	13.4±0.2
Q	0.1±0.05
R	3° ^{+5°} _{-3°}
S	1.2 MAX.
T	0.25
U	0.6±0.15

P32GU-50-9KH-2

Recommended Soldering Conditions

Please consult with our sales offices for soldering conditions of the μ PD431000A.

Types of Surface Mount Device

μ PD431000AGW-xxL	: 32-pin PLASTIC SOP (13.34 mm (525))
μ PD431000AGW-xxLL	: 32-pin PLASTIC SOP (13.34 mm (525))
μ PD431000AGW-Axx	: 32-pin PLASTIC SOP (13.34 mm (525))
μ PD431000AGW-Bxx	: 32-pin PLASTIC SOP (13.34 mm (525))
μ PD431000AGZ-xxLL-KJH	: 32-pin PLASTIC TSOP(I) (8x20) (Normal bent)
μ PD431000AGZ-xxLL-KKH	: 32-pin PLASTIC TSOP(I) (8x20) (Reverse bent)
μ PD431000AGZ-Bxx-KJH	: 32-pin PLASTIC TSOP(I) (8x20) (Normal bent)
μ PD431000AGU-Bxx-9JH	: 32-pin PLASTIC TSOP(I) (8x13.4) (Normal bent)
μ PD431000AGU-Bxx-9KH	: 32-pin PLASTIC TSOP(I) (8x13.4) (Reverse bent)
μ PD431000AGW-xxL-A	: 32-pin PLASTIC SOP (13.34 mm (525))
μ PD431000AGW-xxLL-A	: 32-pin PLASTIC SOP (13.34 mm (525))
μ PD431000AGW-Axx-A	: 32-pin PLASTIC SOP (13.34 mm (525))
μ PD431000AGW-Bxx-A	: 32-pin PLASTIC SOP (13.34 mm (525))
μ PD431000AGZ-xxLL-KJH-A	: 32-pin PLASTIC TSOP(I) (8x20) (Normal bent)
μ PD431000AGZ-xxLL-KKH-A	: 32-pin PLASTIC TSOP(I) (8x20) (Reverse bent)
μ PD431000AGZ-Bxx-KJH-A	: 32-pin PLASTIC TSOP(I) (8x20) (Normal bent)
μ PD431000AGU-Bxx-9JH-A	: 32-pin PLASTIC TSOP(I) (8x13.4) (Normal bent)
μ PD431000AGU-Bxx-9KH-A	: 32-pin PLASTIC TSOP(I) (8x13.4) (Reverse bent)

Quality Grade

- A quality grade of the products is "Standard".
- Anti-radioactive design is not implemented in the products.
- Semiconductor devices have the possibility of unexpected defects by affection of cosmic ray that reach to the ground and so forth.

Revision History

Edition/ Date	Page		Type of revision	Description
	This edition	Previous edition		
14th edition/ Nov. 2009	through	through	Modification	Ordering Information revised.

NOTES FOR CMOS DEVICES

① VOLTAGE APPLICATION WAVEFORM AT INPUT PIN

Waveform distortion due to input noise or a reflected wave may cause malfunction. If the input of the CMOS device stays in the area between V_{IL} (MAX) and V_{IH} (MIN) due to noise, etc., the device may malfunction. Take care to prevent chattering noise from entering the device when the input level is fixed, and also in the transition period when the input level passes through the area between V_{IL} (MAX) and V_{IH} (MIN).

② HANDLING OF UNUSED INPUT PINS

Unconnected CMOS device inputs can be cause of malfunction. If an input pin is unconnected, it is possible that an internal input level may be generated due to noise, etc., causing malfunction. CMOS devices behave differently than Bipolar or NMOS devices. Input levels of CMOS devices must be fixed high or low by using pull-up or pull-down circuitry. Each unused pin should be connected to V_{DD} or GND via a resistor if there is a possibility that it will be an output pin. All handling related to unused pins must be judged separately for each device and according to related specifications governing the device.

③ PRECAUTION AGAINST ESD

A strong electric field, when exposed to a MOS device, can cause destruction of the gate oxide and ultimately degrade the device operation. Steps must be taken to stop generation of static electricity as much as possible, and quickly dissipate it when it has occurred. Environmental control must be adequate. When it is dry, a humidifier should be used. It is recommended to avoid using insulators that easily build up static electricity. Semiconductor devices must be stored and transported in an anti-static container, static shielding bag or conductive material. All test and measurement tools including work benches and floors should be grounded. The operator should be grounded using a wrist strap. Semiconductor devices must not be touched with bare hands. Similar precautions need to be taken for PW boards with mounted semiconductor devices.

④ STATUS BEFORE INITIALIZATION

Power-on does not necessarily define the initial status of a MOS device. Immediately after the power source is turned ON, devices with reset functions have not yet been initialized. Hence, power-on does not guarantee output pin levels, I/O settings or contents of registers. A device is not initialized until the reset signal is received. A reset operation must be executed immediately after power-on for devices with reset functions.

⑤ POWER ON/OFF SEQUENCE

In the case of a device that uses different power supplies for the internal operation and external interface, as a rule, switch on the external power supply after switching on the internal power supply. When switching the power supply off, as a rule, switch off the external power supply and then the internal power supply. Use of the reverse power on/off sequences may result in the application of an overvoltage to the internal elements of the device, causing malfunction and degradation of internal elements due to the passage of an abnormal current.

The correct power on/off sequence must be judged separately for each device and according to related specifications governing the device.

⑥ INPUT OF SIGNAL DURING POWER OFF STATE

Do not input signals or an I/O pull-up power supply while the device is not powered. The current injection that results from input of such a signal or I/O pull-up power supply may cause malfunction and the abnormal current that passes in the device at this time may cause degradation of internal elements. Input of signals during the power off state must be judged separately for each device and according to related specifications governing the device.

- **The information in this document is current as of November, 2009. The information is subject to change without notice. For actual design-in, refer to the latest publications of NEC Electronics data sheets, etc., for the most up-to-date specifications of NEC Electronics products. Not all products and/or types are available in every country. Please check with an NEC Electronics sales representative for availability and additional information.**
- No part of this document may be copied or reproduced in any form or by any means without the prior written consent of NEC Electronics. NEC Electronics assumes no responsibility for any errors that may appear in this document.
- NEC Electronics does not assume any liability for infringement of patents, copyrights or other intellectual property rights of third parties by or arising from the use of NEC Electronics products listed in this document or any other liability arising from the use of such products. No license, express, implied or otherwise, is granted under any patents, copyrights or other intellectual property rights of NEC Electronics or others.
- Descriptions of circuits, software and other related information in this document are provided for illustrative purposes in semiconductor product operation and application examples. The incorporation of these circuits, software and information in the design of a customer's equipment shall be done under the full responsibility of the customer. NEC Electronics assumes no responsibility for any losses incurred by customers or third parties arising from the use of these circuits, software and information.
- While NEC Electronics endeavors to enhance the quality and safety of NEC Electronics products, customers agree and acknowledge that the possibility of defects thereof cannot be eliminated entirely. In addition, NEC Electronics products are not taken measures to prevent radioactive rays in the product design. When customers use NEC Electronics products with their products, customers shall, on their own responsibility, incorporate sufficient safety measures such as redundancy, fire-containment and anti-failure features to their products in order to avoid risks of the damages to property (including public or social property) or injury (including death) to persons, as the result of defects of NEC Electronics products.
- NEC Electronics products are classified into the following three quality grades: "Standard", "Special" and "Specific".

The "Specific" quality grade applies only to NEC Electronics products developed based on a customer-designated "quality assurance program" for a specific application. The recommended applications of an NEC Electronics product depend on its quality grade, as indicated below. Customers must check the quality grade of each NEC Electronics product before using it in a particular application.

"Standard": Computers, office equipment, communications equipment, test and measurement equipment, audio and visual equipment, home electronic appliances, machine tools, personal electronic equipment and industrial robots.

"Special": Transportation equipment (automobiles, trains, ships, etc.), traffic control systems, anti-disaster systems, anti-crime systems, safety equipment and medical equipment (not specifically designed for life support).

"Specific": Aircraft, aerospace equipment, submersible repeaters, nuclear reactor control systems, life support systems and medical equipment for life support, etc.

The quality grade of NEC Electronics products is "Standard" unless otherwise expressly specified in NEC Electronics data sheets or data books, etc. If customers wish to use NEC Electronics products in applications not intended by NEC Electronics, they must contact an NEC Electronics sales representative in advance to determine NEC Electronics' willingness to support a given application.

(Note)

- (1) "NEC Electronics" as used in this statement means NEC Electronics Corporation and also includes its majority-owned subsidiaries.
- (2) "NEC Electronics products" means any product developed or manufactured by or for NEC Electronics (as defined above).